

Jansen Art'System

Lieferprogramm und Verarbeitung

Jansen Art'System

Programme de livraison et usinage

Jansen Art'System

Sales range and assembly



Systemübersicht

Merkmale
Zulassungen
Typenübersicht

Sommaire du système

Caractéristiques
Homologations
Sommaire des types

Summary of system

Characteristics
Authorisations
Summary of types

2

Profilsortiment

Profilübersicht
Profile im Massstab 1:1
Glasleistenübersicht

Assortiment de profilé

Sommaire des profilés
Profilés à l'échelle 1:1
Sommaire des parcloses

Range of profiles

Summary of profiles
Profiles on scale 1:1
Summary of glazing beads

10

Zubehör

Zubehör
Beschläge

Accessoires

Accessoires
Ferrures

Accessories

Accessories
Fittings

23

Beispiele

Schnittpunkte
Anwendungsbeispiele
Anschlüsse am Bau

Exemples

Coupes de détails
Exemples d'application
Raccords au mur

Examples

Section details
Examples of applications
Attachment to structure

62

Technische Hinweise

Conseils techniques

Technical data

109

Beschlageinbau Verarbeitungshinweise

Montage des ferrures Indications d'usage

Installation of fittings Assembly instructions

118

Alle Ausführungen dieser Dokumentation haben wir sorgfältig und nach bestem Wissen zusammengestellt. Wir können aber keine Verantwortung für die Benutzung der vermittelten Vorschläge und Daten übernehmen. Wir behalten uns technische Änderungen ohne Vorankündigung vor.
Aktuelle Version auf www.jansen.com

Nous avons apporté le plus grand soin à l'élaboration de cette documentation. Cependant, nous déclinons toute responsabilité pour l'utilisation faite de nos propositions et de nos données.
Nous nous réservons le droit de procéder à des modifications techniques sans préavis.
Version actuelle sur www.jansen.com

All the information contained in this documentation is given to the best of our knowledge and ability. However, we decline all responsibility for the use made of these suggestions and data.
We reserve the right to effect technical modifications without prior warning.
Current version available at www.jansen.com

Merkmale
Caractéristiques
Characteristics

Jansen Art'System
 Jansen Art'System
 Jansen Art'System





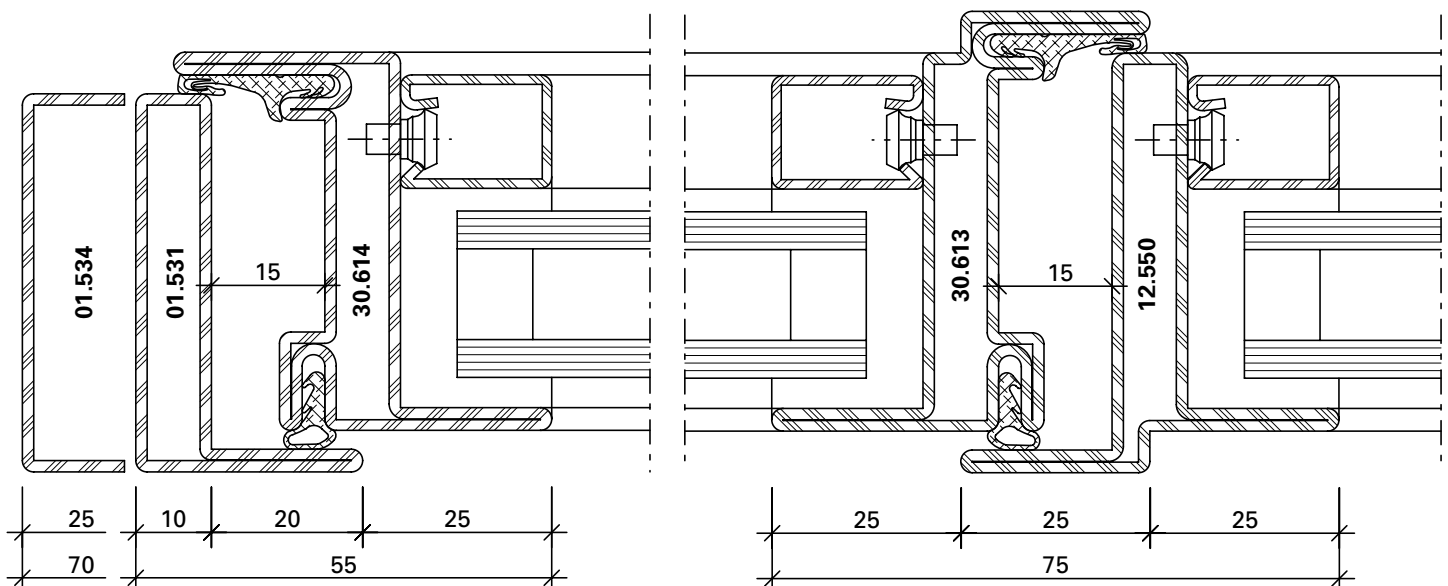

- Flügelprofile mit Innen- und Aussendichtung
- Grosse Auswahl bezüglich Profile und Glasleisten
- Hohlprofile mit sehr guten statischen Eigenschaften
- Äusserst schlanke Profil-Ansichtsbreiten für Flügel und Rahmen / Sprossen
- Werkseigene Biegearbeiten für Rahmen und Flügel mit kleinsten Radien
- Verglasung mittels EPDM-Glasdichtung resp. Versiegelung praktisch unsichtbar
- Grosse Auswahl an Fensterbeschlägen, traditionell aufgesetzt oder zeitgenössisch verdeckt liegend
- Profilsystem speziell für Altbausanierungen entwickelt
- Profilsystem entspricht den technischen Vorgaben der DTU 39 in Frankreich
- Systemkonzept entspricht den Anforderungen der NF P24-351 (Oberflächenbehandlung)
- Hohe Leistungswerte bezüglich Wind-, Wasser- und Luftdichtigkeit
- Dank Doppeldichtung der Flügelprofile werden sehr gute Schallschutzwerte erreicht
- Einbau von Einfach- resp. Isolierglas von 5 bis 27 mm möglich

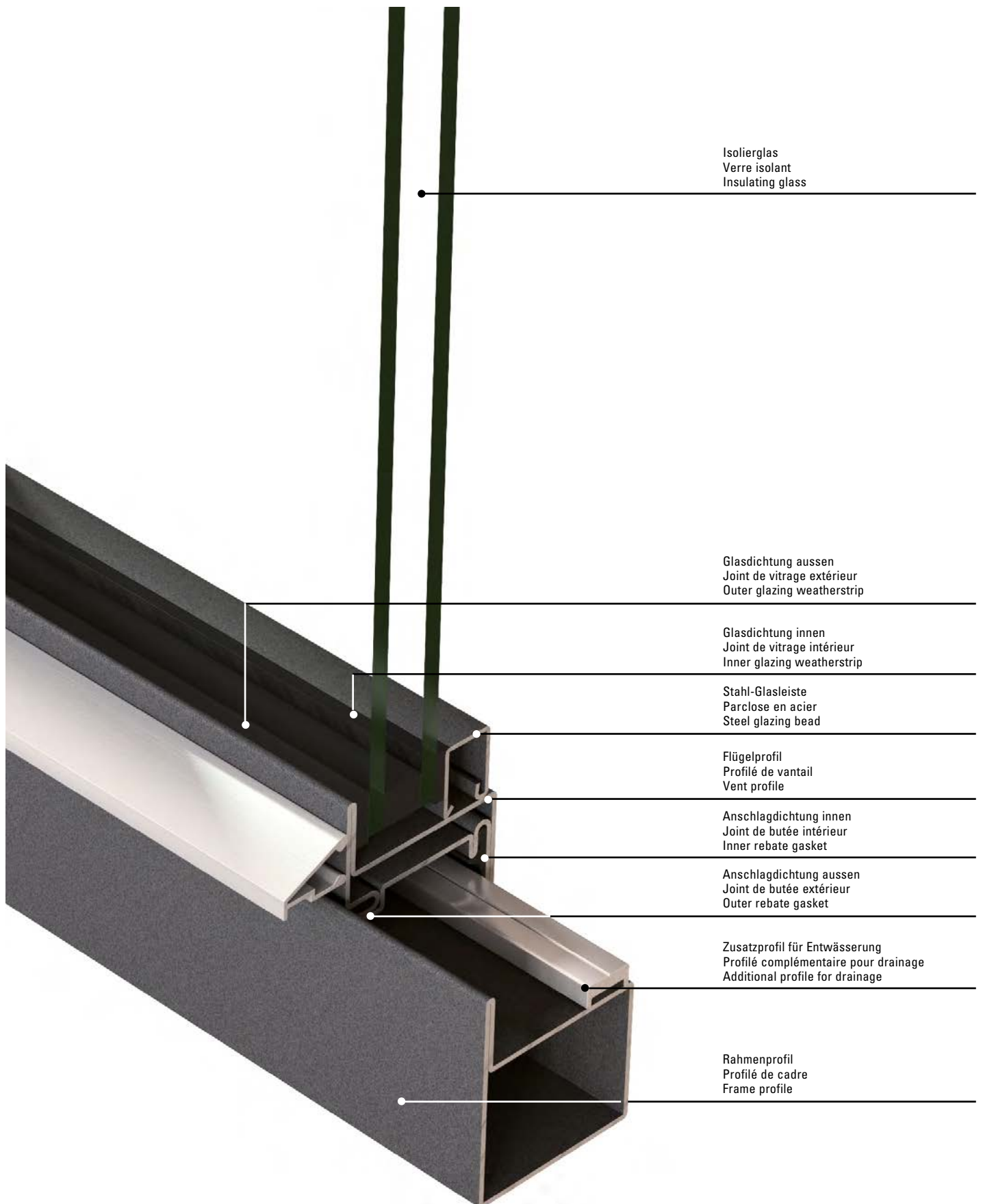
- Profilé de vantail avec double joint
- Grandes variété de profilés et parclozes
- Profilé tubulaire à forte résistance mécanique
- Masse vue (profilés et joints) la plus fine du marché
- Cintrage possible
- Joint de vitrage invisible
- Grand choix de crémones avec styles traditionnel et contemporain
- Gamme préconisée par les ABF
- Conforme au DTU 39 (Prise en feuillure et hauteur de feuillure)
- Conception conforme aux exigences NF P24-351 (Traitement de surface)
- Les plus hautes performances AEV en menuiserie fine acier
- Performances thermiques conformes à la RT 2005
- Grâce aux profilés avec double joints, très hautes performances acoustiques
- Vitrage simple ou isolant, de 5 à 27 mm d'épaisseur

- Vent profiles with internal and external weatherstrip
- Wide selection of profiles and glazing beads
- Hollow profiles with very good structural properties
- Extremely narrow profile face widths for vents and frames/sash bars
- In-house profile bending for frames and vents with the smallest of radii
- Glazing by means of EPDM glazing weatherstrip; sealing almost completely concealed
- Wide range of window fittings, traditionally surface-mounted or concealed in the contemporary style
- Profile system specifically developed for the renovation of old buildings
- Profile system corresponds to the technical specifications of DTU 39 in France
- System concept meets the requirements of NF P24-351 (surface treatment)
- High performance values with regard to wind, water and airtightness
- Very good sound reduction values are achieved thanks to the double weatherstrip in the vent profiles
- Single glazing or insulating glass from 5 to 27 mm can be installed





Norm	Eigenschaft Caractéristique Characteristic	Klassifizierung/Wert Classification / Valeur Classification / Value																	
		npd	C1 (400)	C2 (800)	C3 (1200)	C4 (1600)	C5 (2000)	Exxx (>2000)	npd	1A (0)	2A (50)	3A (100)	4A (150)	5A (200)	6A (250)	7A (300)	8A (450)	9A (600)	Exxx (>750)
 EN 12210	Widerstandsfähigkeit bei Windlast Résistance à la pression du vent Resistance to wind load	npd	C1 (400)	C2 (800)	C3 (1200)	C4 (1600)	C5 (2000)	Exxx (>2000)											
 EN 12208	Schlagregendichtheit Etanchéité à la pluie battante Watertightness	npd	1A (0)	2A (50)	3A (100)	4A (150)	5A (200)	6A (250)	7A (300)	8A (450)	9A (600)	Exxx (>750)							
 EN ISO 10140	Schalldämmung R_w (C, C_{tr}) (dB) Isolation phonique R_w (C, C_{tr}) (dB) Sound insulation R_w (C, C_{tr}) (dB)	npd	bis R_w 43 dB jusqu'à R_w 43 dB up to R_w 43 dB																
 EN ISO 10077-2	Wärmedurchgangskoeffizient U_f (W/(m²·K)) Transmission thermique U_f (W/(m²·K)) Thermal production U_f (W/(m²·K))	npd	ab 5,2 W/m ² ·K à partir de 5,2 W/m ² ·K from 5,2 W/m ² ·K																
 EN 12207	Luftdurchlässigkeit Perméabilité à l'air Air permeability	npd	1 (150)		2 (300)		3 (600)		4 (600)										
 EN 13115	Bedienkräfte Forces de manœuvre Operating forces	npd	0			1			2										
 EN 13115	Mechanische Festigkeit Résistance mécanique Mechanical strength	npd	1		2		3		4										

npd = keine Leistung festgestellt
(no performance determined)

npd = Aucune performance
déterminée
(no performance determined)

npd = no performance determined

Elementgrößen
(gemäss Gutachten/CE-Kennzeichen)

Dimensions des éléments
(selon rapport/label CE)

Size of elements
(according to report/CE marking)

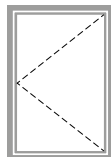

Dreh-Fenster einflügelig
nach innen öffnend
Max. Masse:
872 x 2072 mm (FFBxFFH)
Min. Masse:
310 x 310 mm (FFBxFFH)

Fenêtre à la française
à un vantail
ouvrant vers l'intérieur
Dimensions max.:
872 x 2072 mm (FFBxFFH)
Dimensions min.:
310 x 310 mm (FFBxFFH)

Single-vent side-hung window
inward opening
Max. dimensions:
872 x 2072 mm (FFBxFFH)
Min. dimensions:
310 x 310 mm (FFBxFFH)

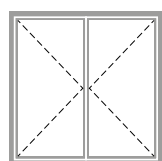

Dreh-Fenster zweiflügelig
nach innen öffnend
Max. Masse:
GF = 872 x 2072mm (FFBxFFH)
SF = 872 x 2072 mm (FFBxFFH)
Min. Masse:
GF = 310 x 310 mm (FFBxFFH)
SF = 310 x 310 mm (FFBxFFH)

Fenêtre à la française
à deux vantaux
ouvrant vers l'intérieur
Dimensions max.:
GF = 872 x 2072mm (FFBxFFH)
SF = 872 x 2072 mm (FFBxFFH)
Dimensions min.:
GF = 310 x 310 mm (FFBxFFH)
SF = 310 x 310 mm (FFBxFFH)

Double-vent side-hung window
inward opening
Max. dimensions:
GF = 872 x 2072mm (FFBxFFH)
SF = 872 x 2072 mm (FFBxFFH)
Min. dimensions:
GF = 310 x 310 mm (FFBxFFH)
SF = 310 x 310 mm (FFBxFFH)

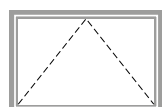

Kipp-Fenster
nach innen öffnend
Max. Masse:
2072 x 872 mm (FFBxFFH)
oder
872 x 1980 mm (FFBxFFH)
Min. Masse:
310 x 310 mm (FFBxFFH)

Fenêtre à soufflet
ouvrant vers l'intérieur
Dimensions max.:
2072 x 872 mm (FFBxFFH)
ou
872 x 1980 mm (FFBxFFH)
Dimensions min.:
310 x 310 mm (FFBxFFH)

Bottom-hung window
inward opening
Max. dimensions:
2072 x 872 mm (FFBxFFH)
or
872 x 1980 mm (FFBxFFH)
Min. dimensions:
310 x 310 mm (FFBxFFH)

FFB = Flügelfalzbreite
FFH = Flügelfalzhöhe
GF = Gangflügel
SF = Standflügel

FFB = Largeur de feuillure du vantail
FFH = Hauteur de feuillure du vantail
GF = Vantail de service
SF = Vantail semi-fixe

FFB = Vent rebate width
FFH = Vent rebate height
GF = Access vent
SF = Secondary vent

JANlsoft

JANlsoft ermöglicht die Planung, Kalkulation und Konstruktion von Jansen Systemen für Fenster, Türen und Fassaden in 2D sowie 3D. Mit der neuen Version können Planer und Verarbeiter Angebote und Bestellungen mit den entsprechenden Detailzeichnungen und Berechnungen einfach erstellen. Dank der optimierten Softwarefunktionen lässt sich der Prozess von der Arbeitsvorbereitung über die Fertigung noch effizienter gestalten.

Jansen Docu Center

Die Plattform zum effizienten Arbeiten mit Jansen Dokumentationen. Im Jansen Docu Center stehen alle Produktinformationen jederzeit digital in der aktuellsten Version zur Verfügung: von Architekten-Informationen über Bestell- und Fertigungskatalogen bis hin zu Anleitungen und Prospekten sowie Videos. Die Inhalte können einfach und schnell aufgerufen werden. Ein für den Anwender komfortables papierloses Arbeiten, das zahlreiche Vorteile bietet.

Download CAD Daten

DXF

DWG

Sie können die Zeichnungen in den Formaten DXF und/oder DWG herunterladen. Klicken Sie auf das entsprechende Icon und der Download erfolgt.

Die Hinweise «Artikelbibliothek/Türbeschläge/Fensterbeschläge» bedeuten, dass Sie mit einem Klick die gesamte Artikelbibliothek des entsprechenden Systems herunterladen (Profile, Beschläge, Glasleisten, Zubehör etc.).

JANlsoft

JANlsoft permet l'étude, le calcul et la construction de systèmes Jansen en 2D et 3D pour les fenêtres, les portes et les façades. La nouvelle version permet aux projeteurs et aux transformateurs d'établir facilement des offres et des commandes avec les plans de détail et les calculs. Des préparatifs du travail à la commande de la machine, le processus peut être coordonné de manière encore plus efficace grâce aux fonctions optimisées du logiciel.

Jansen Docu Center

La plate-forme pour travailler efficacement avec les documentations Jansen. Le Jansen Docu Center met à votre disposition les informations sur les produits, en format numérique et dans une version actualisée: des catalogues de commande et de fabrication aux instructions et prospectus, en passant par les informations destinées aux architectes et vidéos. Les contenus sont facilement et rapidement accessibles. Une manière de travailler confortable et offrant de nombreux avantages.

Télécharger fichiers DAO

DXF

DWG

Vous pouvez télécharger les dessins aux formats DXF et/ou DWG. Cliquez sur l'icône correspondante et le téléchargement s'effectuera.

Les indications «Bibliothèque des articles/Ferures de porte/Ferrures de fenêtres» signifie que vous téléchargez la totalité de la bibliothèque des articles du système donné (profilés, ferrures, parcloles, accessoires etc.).

JANlsoft

JANlsoft allows Jansen systems for windows, doors and façades to be planned, calculated and designed in 2D and 3D. Using the new version, developers and fabricators can easily create quotations and orders with the corresponding detailed drawings and calculations. Thanks to optimised software functionality, the procedure from process planning to fabrication can be made even more efficient.

Jansen Docu Center

The platform for working efficiently with Jansen documentation. The latest version of all the product information is available digitally at any time in the Jansen Docu Center – from order and fabrication manuals to architect information, instructions and brochures and videos. The content can be retrieved quickly and easily. The user can work conveniently without paper, which has numerous benefits.

Download CAD files

DXF

DWG

You can download the drawings in DXF and/or DWG format. Click on the relevant icon to begin the download.

The items «Article library/Door fittings/Window fittings» means that you download the entire article library for the corresponding system with one click (profiles, fittings, glazing beads, accessories etc.).

Empfehlung für die Angabe von Leistungswerten

Die angegebenen Leistungswerte, welche in dieser Dokumentation publiziert sind, wurden unter optimalen Randbedingungen ermittelt. Das heisst beste Fertigungsbedingungen mit allen Verarbeitungshilfsmitteln, ohne Zeitdruck in der Fertigung und idealen Einbaubedingungen. All diese Voraussetzungen sind im Alltag nicht immer erfüllt und müssen bei der Angabe von Leistungswerten durch den Metallbauer berücksichtigt werden, welcher mit seiner Unterschrift für diese Werte bürgt.

Sind in einer Leistungsausschreibung kleinere Werte als die von uns ermittelten gefordert, reicht es auch aus, wenn Sie diese Werte in Ihrer Klassifizierung angeben.

Recommandation concernant l'indication des valeurs de performance

Les valeurs de performance indiquées, qui sont publiées dans cette documentation, ont été établies dans des conditions marginales optimales. Cela signifie dans les meilleures conditions de fabrication avec tous les auxiliaires de transformation, sans pression horaire dans la production et dans des conditions idéales de montage. Toutes ces conditions ne sont pas toujours remplies au quotidien et doivent être prises en compte par le menuisier métallique lors de l'indication des valeurs de performance, dont il se porte garant par sa signature.

Si des valeurs inférieures à celles établies sont exigées dans un appel d'offres, cela suffit d'indiquer ces valeurs dans leur classification.

Recommendation for specifying performance values

The specified performance values, which are published in this document, have been recorded under optimum conditions, i.e. the best fabrication conditions with all fabrication aids and ideal installation conditions, without time pressure. All of these prerequisites are not always met in everyday life and must be taken into consideration by the metal fabricator, who vouches for these values with his/her signature when specifying the performance values.

If lower values than those recorded by us are required in a specification, it is sufficient if you specify these values in your classification.



Toleranzen
Tolérances
Tolerances



Bedienungs-, Pflege- und
Wartungsanleitung (598.461)
Instructions d'emploi, d'entretien
et de maintenance (598.468)
Operating and maintenance
instructions (598.467)

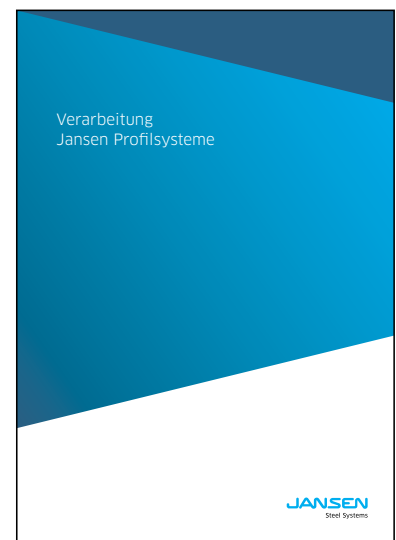

Verarbeitung Jansen-Profilsysteme
(598.477)
Usinage systèmes de profilés Jansen
(598.491)
Fabrication of Jansen profile systems
(598.492)

Fenster

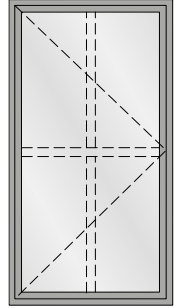

Fenêtres

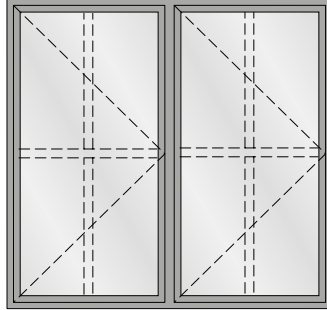

Windows

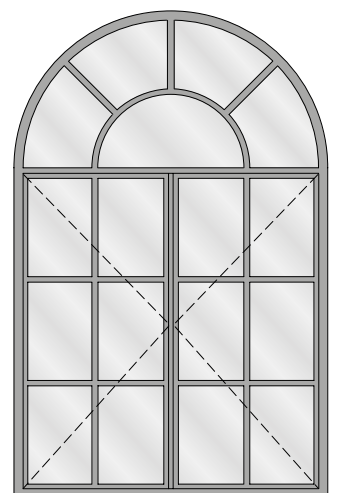
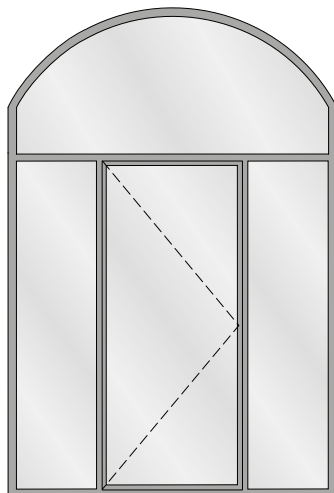
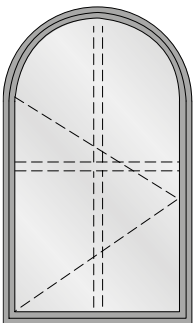
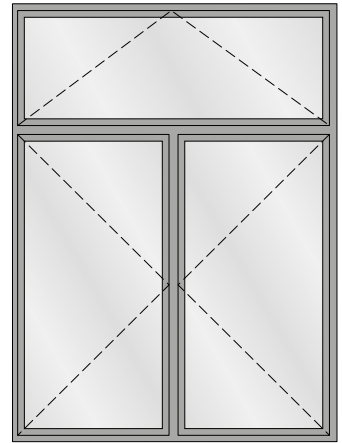
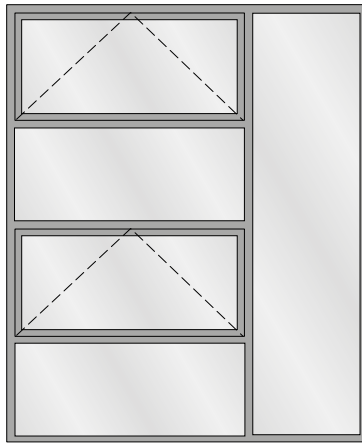
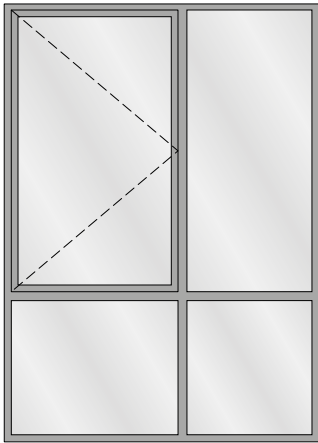
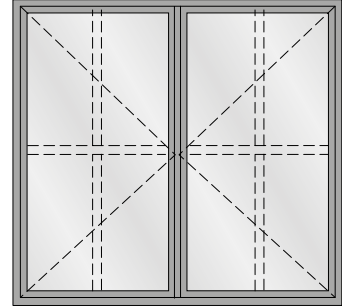

**Fenstertüren
mit Fensterbeschlag**

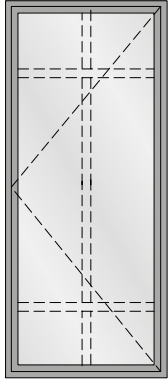

**Portes-fenêtres
avec ferrure de fenêtre**

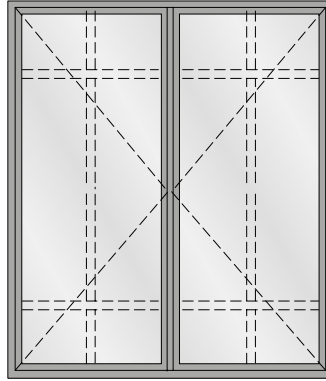

**Windows-doors
with window fitting**

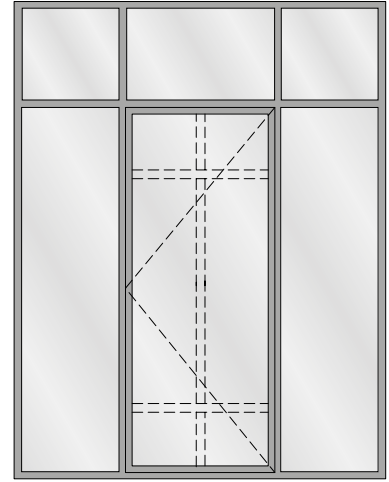

**Fenstertüren
mit Schloss und Drücker***

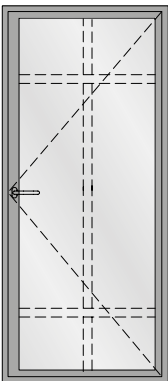

**Portes-fenêtres
avec serrure et poignée***

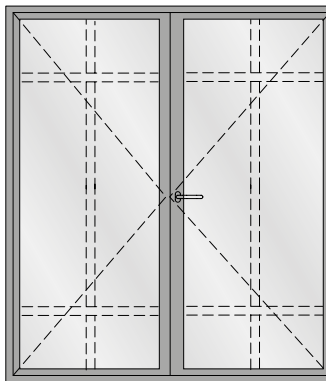

**Windows-doors
with lock and handle***

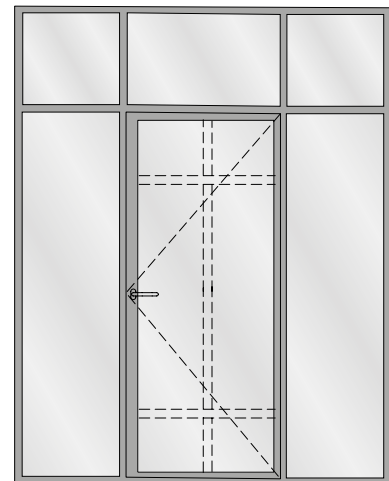

* Sonderkonstruktion
(nach Produktnorm EN 14351 nicht
geprüft)

* Construction spéciale
(non contrôlé selon la norme
produit EN 14351)

* Special construction
(not tested in accordance with
the EN 14351 product standard)

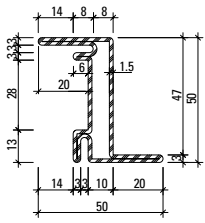

30.614 Z

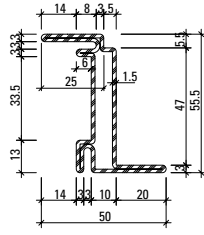

30.613 Z

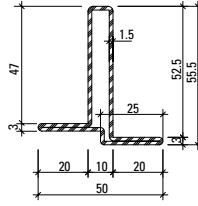

12.550 Z

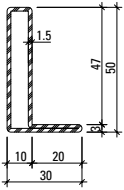

01.531
01.531 Z

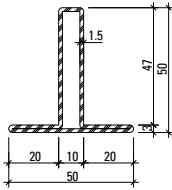

02.531
02.531 Z

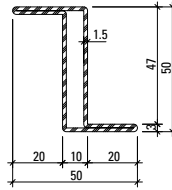

03.531
03.531 GV+GC

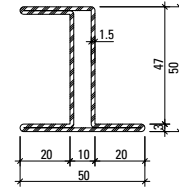

05.531 Z

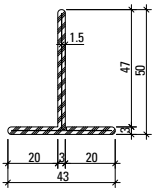

400.023
400.023 Z

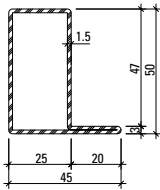

01.534
01.534 Z

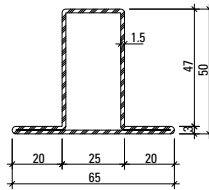

02.534
02.534 Z

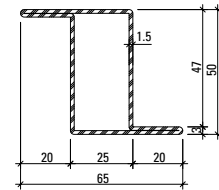

03.534
03.534 Z

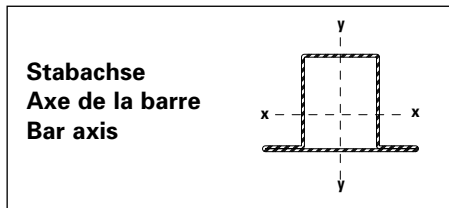

Artikelbibliothek
 Bibliothèque des articles
 Article library

DXF **DWG**

Profil-Nr.	G kg/m	F cm ²	I _x cm ⁴	W _x cm ³	I _y cm ⁴	W _y cm ³	U m ² /m
30.614	2,710	3,45	12,61	4,79	3,65	1,38	0,234
30.613	2,820	3,60	15,98	5,44	3,66	1,38	0,244
12.550	2,340	3,00	9,49	2,58	3,27	1,30	0,205
01.531	1,770	2,26	6,55	2,11	1,42	0,67	0,155
02.531	2,240	2,86	8,00	2,31	3,26	1,30	0,195
03.531	2,240	2,85	10,63	4,25	3,25	1,30	0,194
05.531	2,700	3,44	13,37	4,61	4,53	1,64	0,234

Profil-Nr.	G kg/m	F cm ²	I _x cm ⁴	W _x cm ³	I _y cm ⁴	W _y cm ³	U m ² /m
400.023	2,060	2,62	6,63	1,87	1,91	0,88	0,182
01.534	2,130	2,71	9,35	3,11	4,78	1,73	0,185
02.534	2,590	3,30	10,99	3,30	8,56	2,63	0,224
03.534	2,590	3,30	10,99	3,30	8,56	2,63	0,224

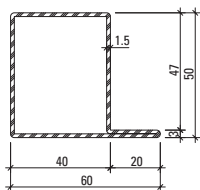

01.564
01.564 Z

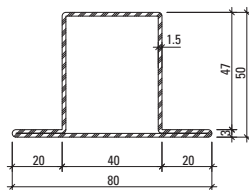

02.564
02.564 Z

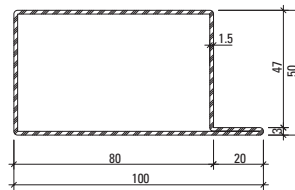

01.592
01.592 Z

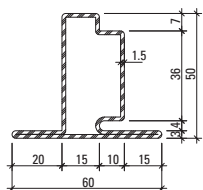

30.106
30.106 Z

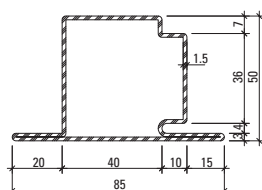

30.107
30.107 Z

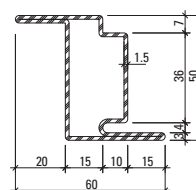

30.406
30.406 Z

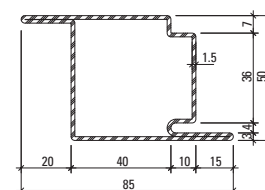

30.407
30.407 Z

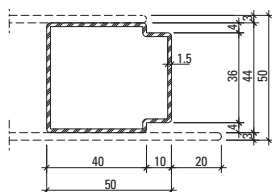

81.009
81.009 GV+GC

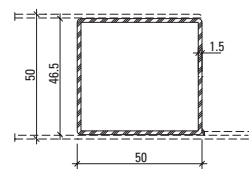

400.049
400.049 GV+GC

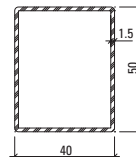

400.048
400.048 GV+GC

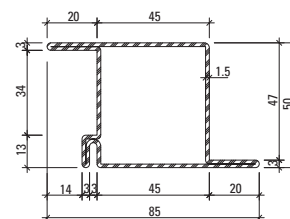

FR 92.00.323*

* auf Anfrage (Länge 4600 mm)

* sur demande (longueur 4600 mm)

* on request (length 4600 mm)

Werkstoffe

Artikel-Nr.
ohne Zusatz = blank
mit Z = bandverzinkter Stahl
mit GV+GC = aussen galvanisch
 verzinkt und
 gelbchromatiert

Matériaux

No. d'article
**sans
 supplément** = brut
avec Z = bande d'acier zinguée
avec GV+GC = zingués galvanique
 à l'extérieur et
 chromatisé jaune

Materials

Part no.
**without
 addition** = bright
with Z = strip galvanised steel
with GV+GC = outside galvanised
 and yellow chromated

Profil-Nr.	G kg/m	F cm ²	I _x cm ⁴	W _x cm ³	I _y cm ⁴	W _y cm ³	U m ² /m
01.564	2,490	3,17	12,10	4,12	11,20	3,25	0,216
02.564	2,950	3,75	13,90	4,31	17,60	4,40	0,255
01.592	3,430	4,37	19,30	6,86	46,9	8,80	0,296
30.106	2,830	3,60	10,87	3,19	7,52	2,41	0,230
30.107	3,450	4,40	16,09	4,97	24,97	5,64	0,280
30.406	2,830	3,60	13,79	5,31	7,52	2,41	0,230

Profil-Nr.	G kg/m	F cm ²	I _x cm ⁴	W _x cm ³	I _y cm ⁴	W _y cm ³	U m ² /m
30.407	3,450	4,40	18,48	7,16	24,97	5,64	0,280
81.009	2,090	2,67	7,79	3,54	9,63	3,76	0,182
400.048	2,050	2,58	9,46	3,78	6,70	3,35	0,177
400.049	2,200	2,77	10,61	4,24	9,49	4,08	0,190
92.00.323	3,410	4,35	18,18	24,32	6,79	5,38	0,294

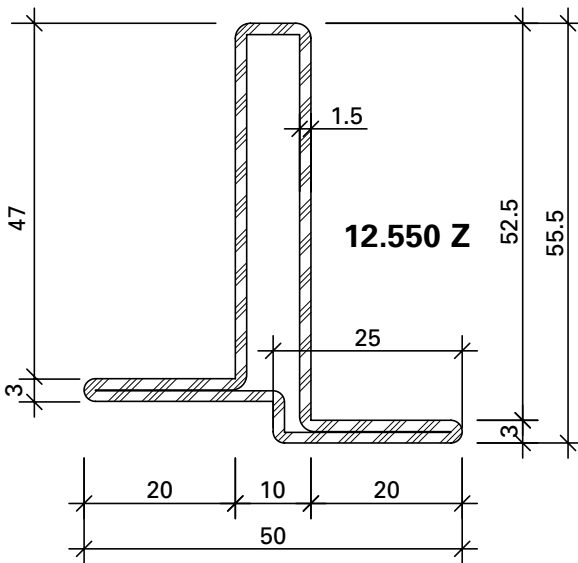
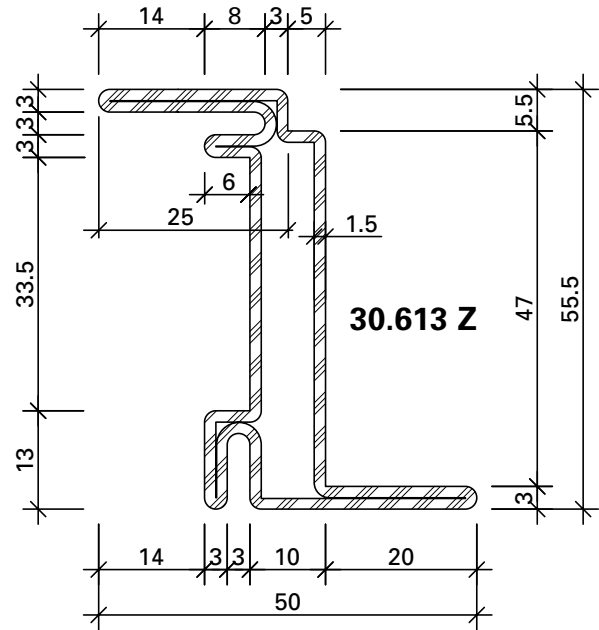
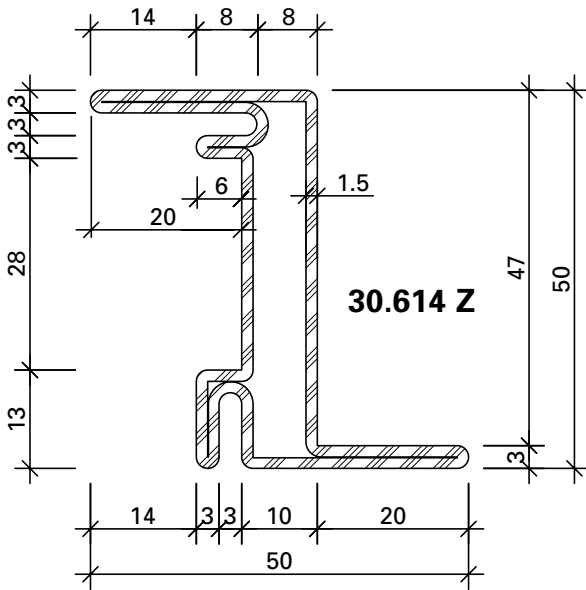

455.046

Anschlagdichtung
 EPDM, schwarz
 VE = 100 m

455.046

Joint de butée
 EPDM, noir
 UV = 100 m

455.046

Rebate gasket
 EPDM, black
 PU = 100 m

Werkstoffe

Artikel-Nr.

ohne Zusatz = blank

mit Z = bandverzinkter Stahl

Matériaux

No. d'article

sans supplément = brut

avec Z = bande d'acier zinguée

Materials

Part no.

without addition = bright

with Z = strip galvanised steel

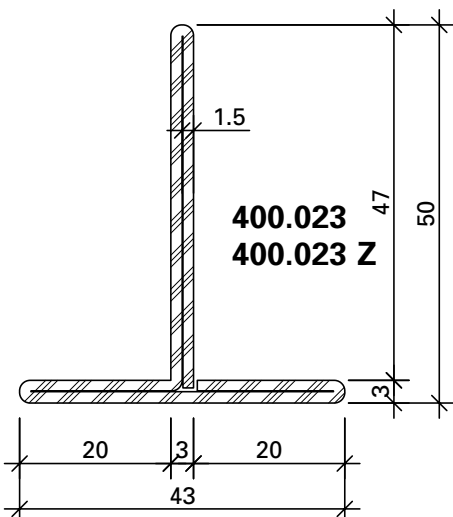
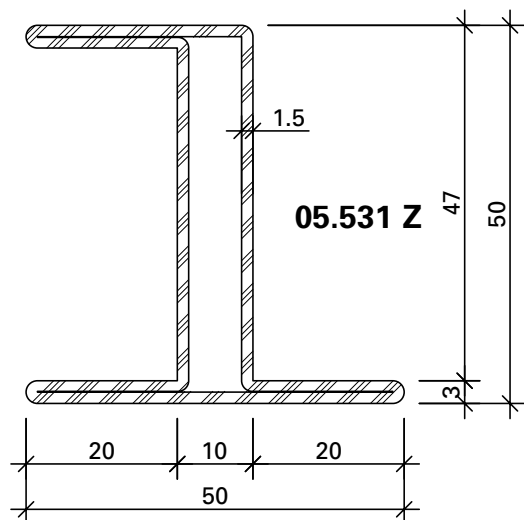
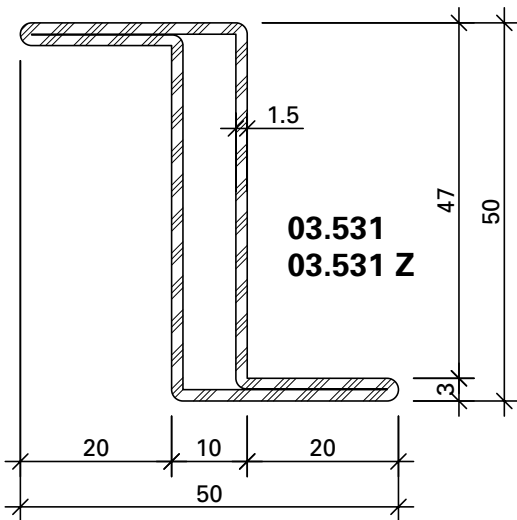
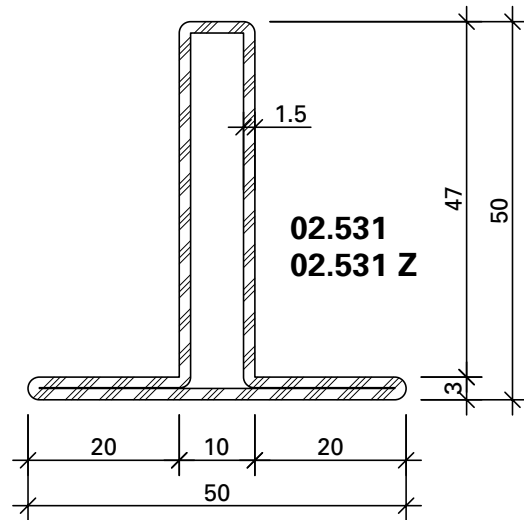
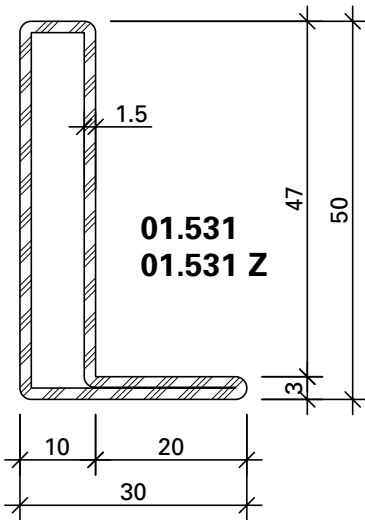

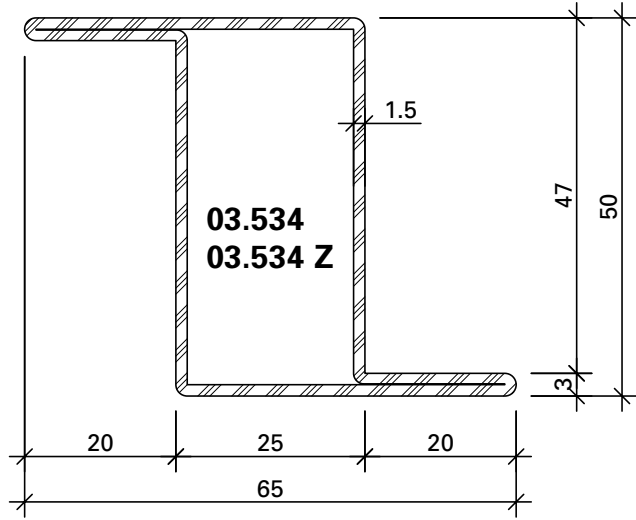
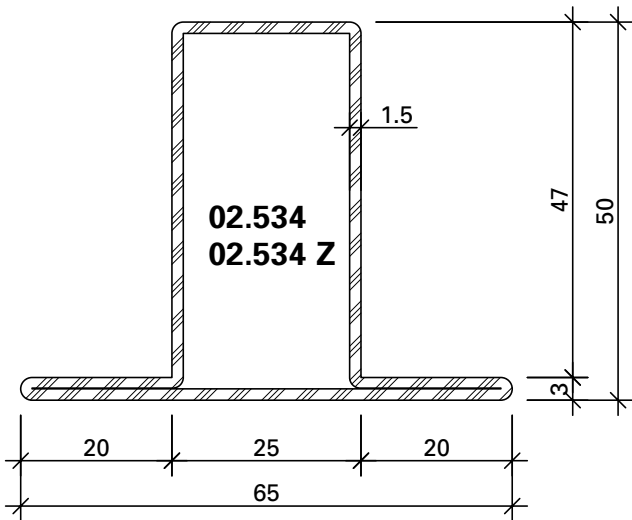
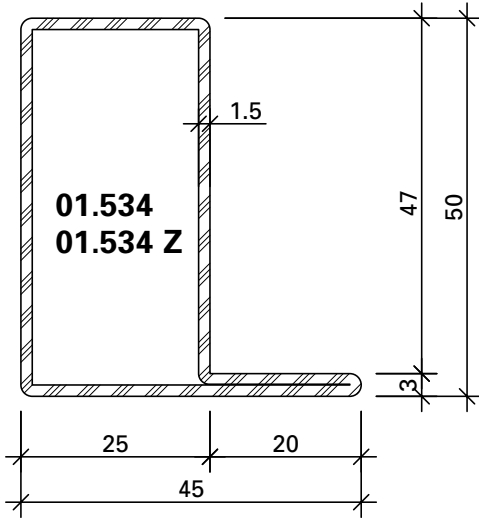

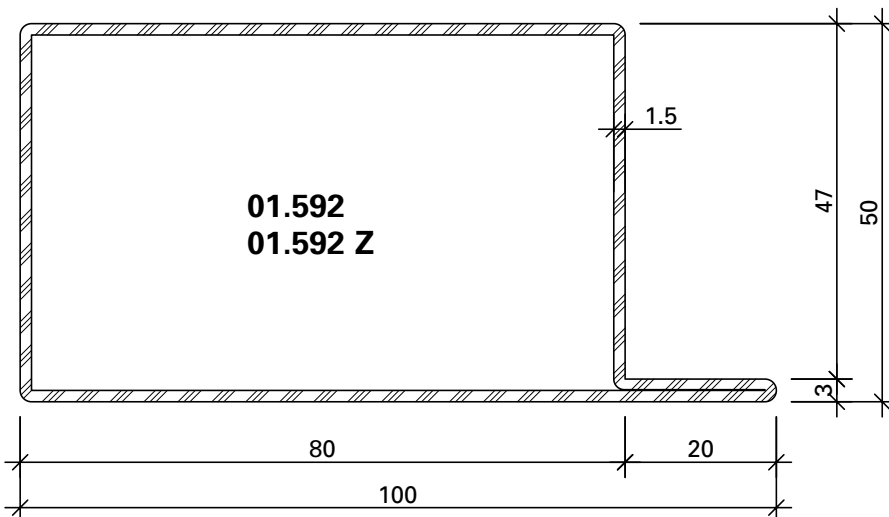
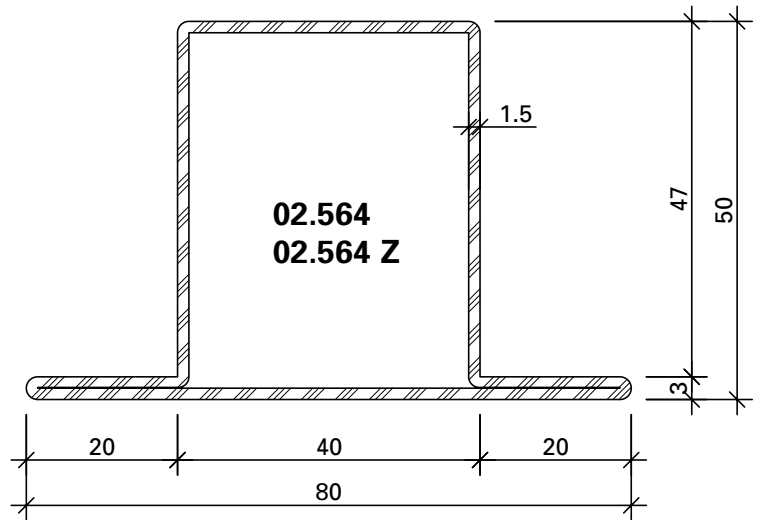
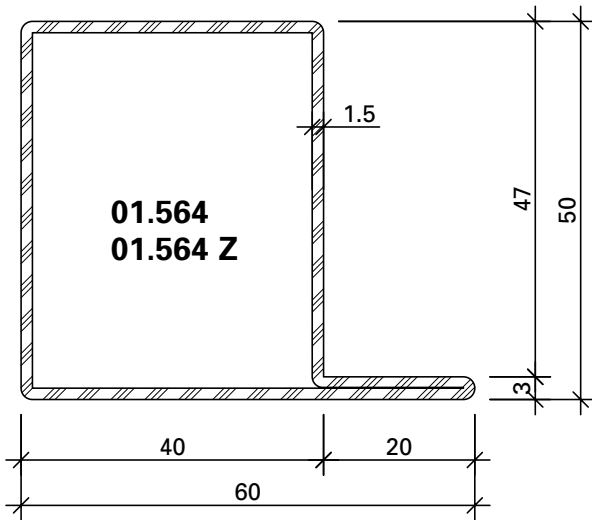

Artikelbibliothek
Bibliothèque des articles
Article library

DXF **DWG**

Zusätzliche Profile für Fenstertüren

Profilés complémentaires pour portes-fenêtres

Additional profiles for door-windows

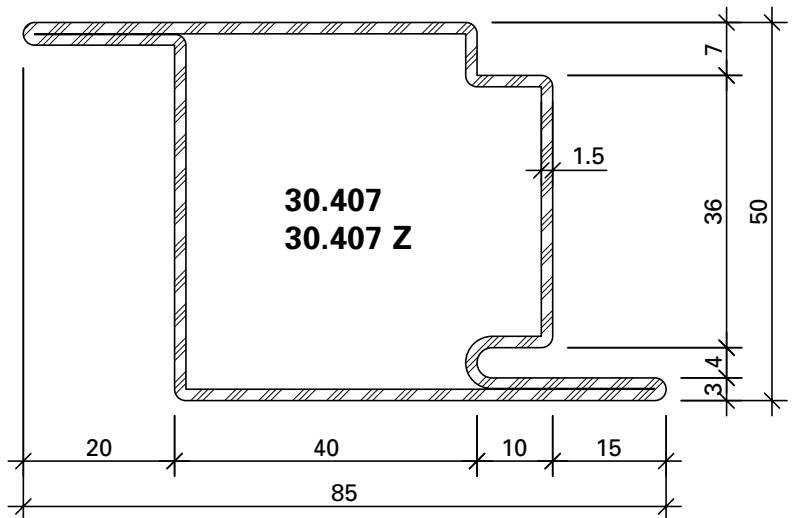
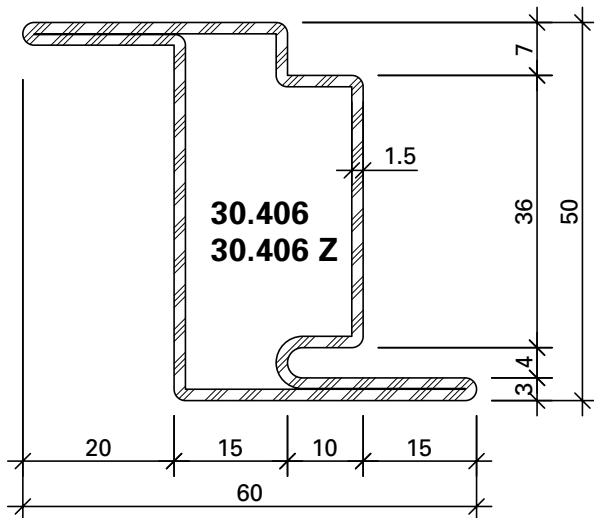
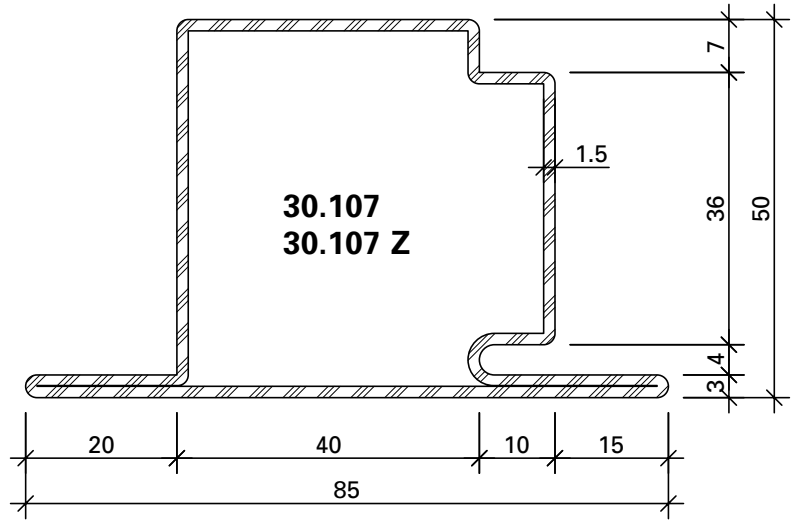
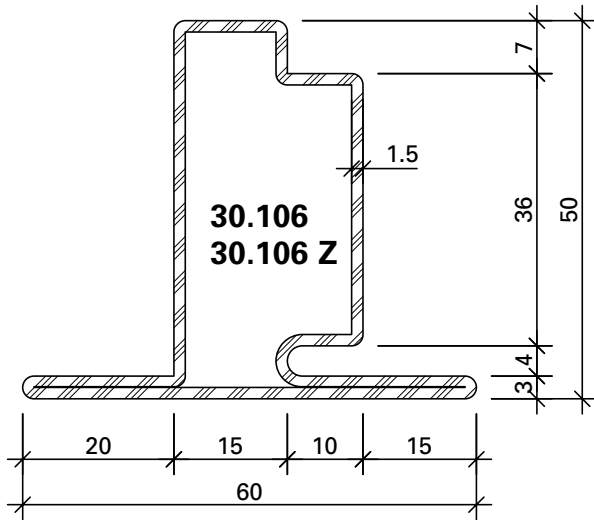

Werkstoffe

Artikel-Nr.

ohne Zusatz = blank

mit Z = bandverzinkter Stahl

mit GV+GC = aussen galvanisch
 verzinkt und
 gelbchromatiert

Matériaux

No. d'article

**sans
 supplément** = brut

avec Z = bande d'acier zinguée

avec GV+GC = zingués galvanique
 à l'extérieur et
 chromatisé jaune

Materials

Part no.

**without
 addition** = bright

with Z = strip galvanised steel

with GV+GC = outside galvanised
 and yellow chromated

Zusätzliche Profile für Fenstertüren

Profilés complémentaires pour portes-fenêtres

Additional profiles for door-windows

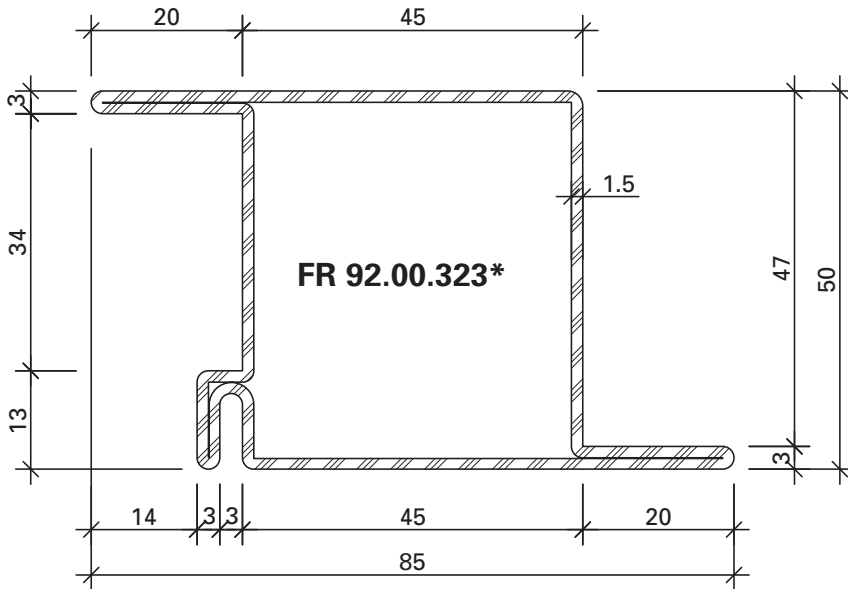

* auf Anfrage (Länge 4600 mm)
 * sur demande (longueur 4600 mm)
 * on request (length 4600 mm)

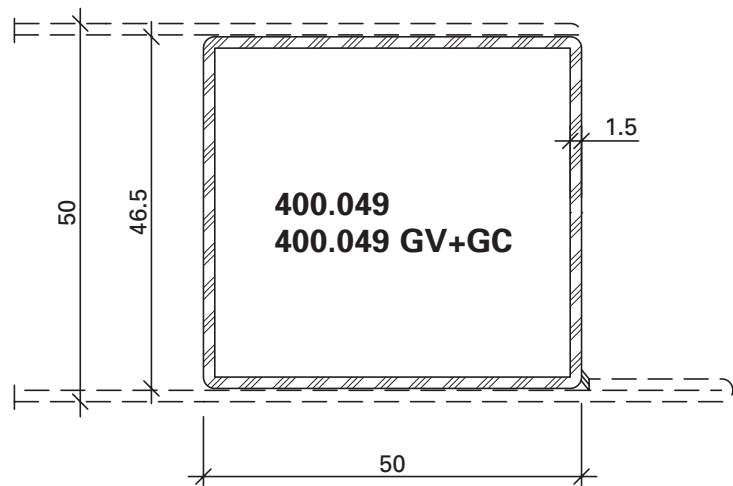
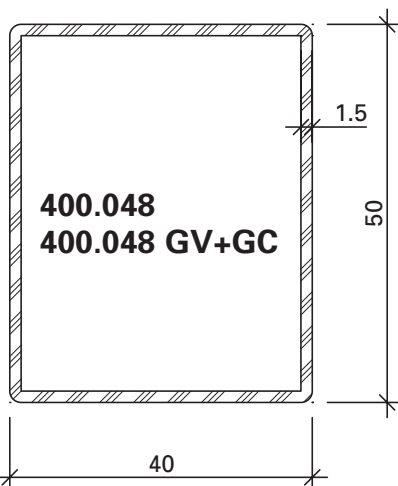
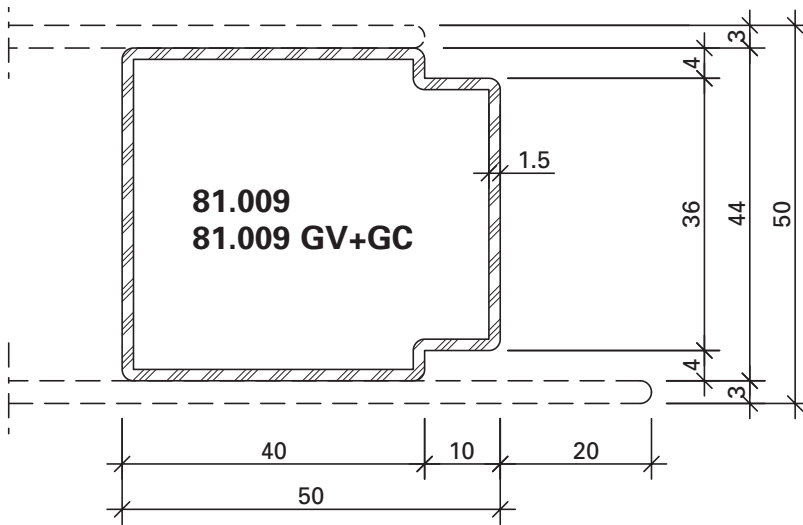

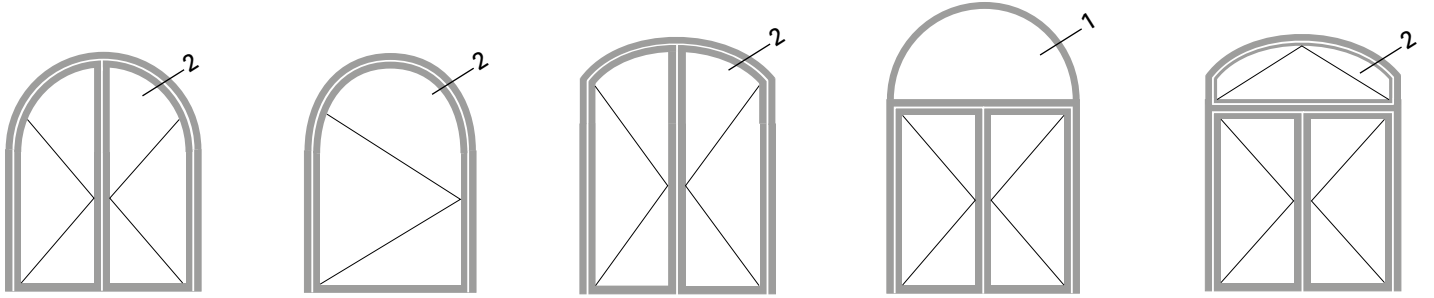

1.0

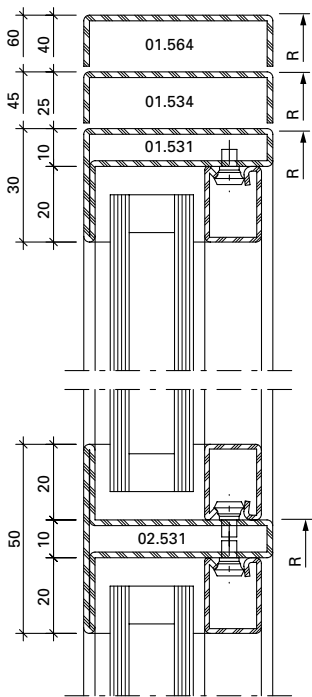

2.0

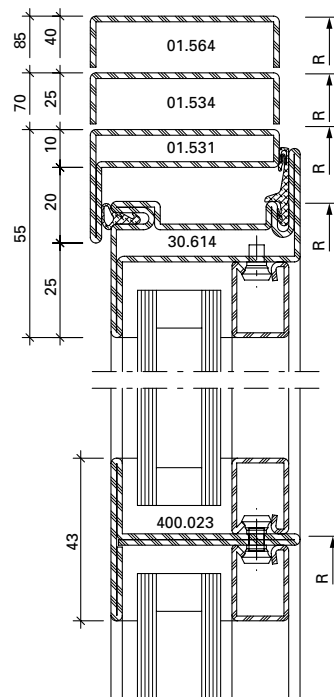

2.1

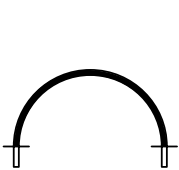
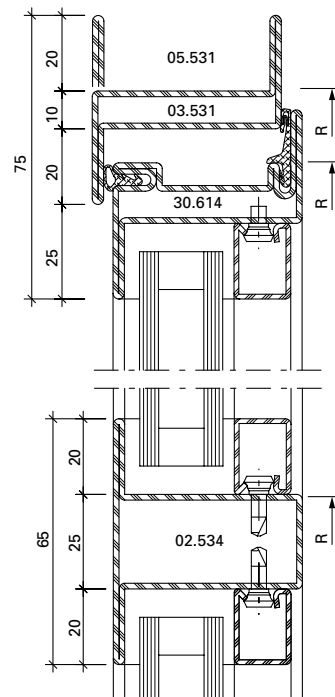

Halbrundbogen
 Arc semi-circulaire
 Semi-circular arch

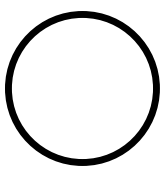

Rundbogen
 Arc en plein centre
 Round arch

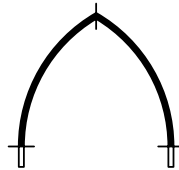

Spitzbogen
 Arc en ogive
 Gothic arch



Stichbogen
 Arc bombé
 Segmented arch



Korbbogen
 Anse de panier
 Oval arch

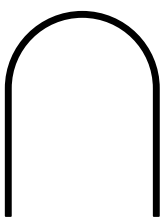

Halbrundbogen mit Schenkel
 Arc surhaussé prolongée
 Semi-circular arch with side extension

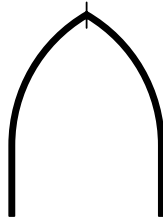

Spitzbogen mit Schenkel
 Arc en ogive prolongée
 Gothic arch with side extension

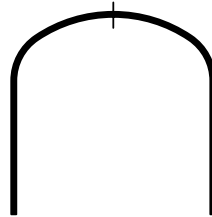



Korbbogen mit Schenkel
 Anse de panier prolongée
 Oval arch with side extension

Bogenfenster
Fenêtres cintrées
Arched windows

Jansen Art'System
 Jansen Art'System
 Jansen Art'System

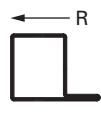
Profil Profilé Profile	Min. Radius Rayon min. Min. radius R	
------------------------------	---	--

	blank brut bright	verzinkt zinguées galvanised
	mm	mm
01.531	350	
01.534	400	500
01.564	500	600

		
02.531	400	400
02.534	600	700
02.564	700	800

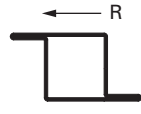
		
03.531	600	
03.534	600	700

		
05.531		300

		
30.614		300

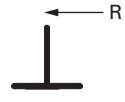
		
400.023	800	800

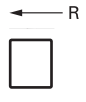
		
400.048	600	900*
400.049	750	950*

* GV+GC

Andere Profiltypen sowie im Grundriss gebogene Profile auf Anfrage.

Die Radien-Angaben beziehen sich auf die langjährige Erfahrung und Fertigung im Hause Jansen.

Stahl-Glasleisten Parcloses en acier Steel glazing beads	Min. Radius Rayon min. Min. radius R
--	---

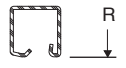
	
402.112 Z	650 mm
402.115 Z	500 mm
402.120 Z	600 mm
402.125 Z	750 mm
402.130 Z	800 mm
402.135 Z	1500 mm
402.140 Z	

Stahl-Glasleisten Parcloses en acier Steel glazing beads	Min. Radius Rayon min. Min. radius R
--	---

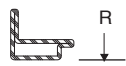
	
62.507 GV+GC	400 mm
62.508 GV+GC	500 mm
62.509 GV+GC	600 mm

Autres types de profilés et profilés au tracé cintré sur demande.

Les rayons indiqués se fondent sur la longue expérience et la fabrication au sein de la maison Jansen.

Aluminium-Glasleisten Parcloses en aluminium Aluminium glazing beads	Min. Radius Rayon min. Min. radius R
--	---

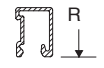
	
404.109	400 mm
404.112	400 mm
404.115	400 mm
404.120	400 mm
404.125	450 mm
404.130	500 mm
404.135	600 mm

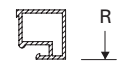
	
405.103	500 mm
405.106	500 mm
405.110	500 mm
405.115	500 mm
405.120	500 mm
405.125	800 mm
405.130	1000 mm
406.903	500 mm
406.905	500 mm
406.907	500 mm
406.909	600 mm

Other profile types and profiles curved in the floor plan are available on request.

The radii specifications are based on the many years of experience Jansen has in fabrication.

Glasleisten (Massstab 1:2)
Parcloses (échelle 1:2)
Glazing beads (scale 1:2)

Jansen Art'System
 Jansen Art'System
 Jansen Art'System

Glasleisten aus bandverzinktem Stahl (Länge 6 m)

Parcloses en bande d'acier zinguée (longueur 6 m)

Glazing beads made of strip galvanised steel (length 6 m)

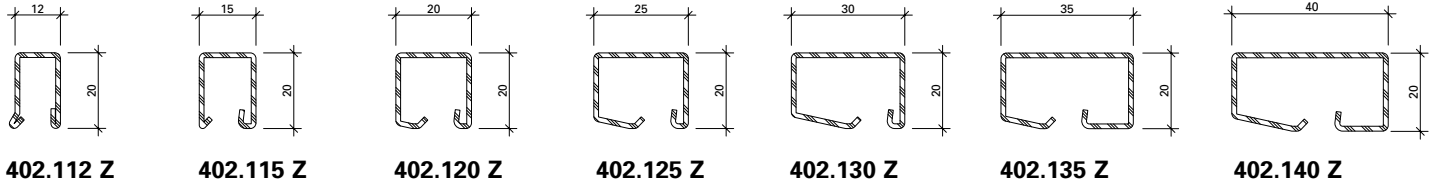

 **450.007**
Befestigungsknopf
 VE = 50 Magazine à 10 Knöpfe
Bouton de fixation
 UV = 50 magasins à 10 pièces
Fastening stud
 PU = 50 magazines with 10 studs

 **450.008**
Befestigungsknopf
 VE = 400 Magazine à 10 Knöpfe
Bouton de fixation
 UV = 400 magasins à 10 pièces
Fastening stud
 PU = 400 magazines with 10 studs

 **450.006**
Befestigungsknopf (kurz) SR1
 Bohrdurchmesser ø 3,5 mm
 VE = 100 Stück
Bouton de fixation (court) SR1
 Diamètre de perçage ø 3,5 mm
 UV = 100 pièces
Fastening stud (short) SR1
 Hole diameter ø 3,5 mm
 PU = 100 pieces

Winkelkontur-Stahl-Glasleisten (Länge ca. 6 m)

Parcloses en acier à contour angulaire (longueur env. 6 m)

Angle contour steel glazing beads (length approx. 6 m)

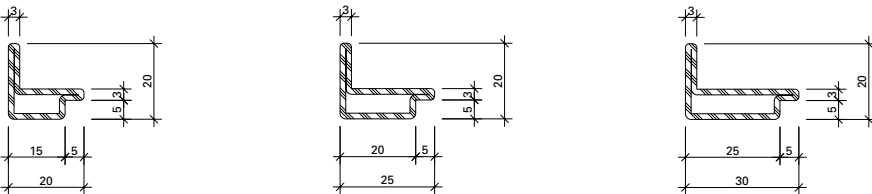

62.507 GV+GC

62.508 GV+GC

62.509 GV+GC

GV+GC = aussen galvanisch verzinkt ca. 15 µm und gelbchromatiert (EN 12329 – Fe//Zn15//C)

GV+GC = zingués galvanique env. 15 µm à l'extérieur et chromatisé jaune (EN 12329 – Fe//Zn15//C)

GV+GC = outside galvanised approx. 15 µm and yellow chromated (EN 12329 – Fe//Zn15//C)

Artikel-Nr.	G kg/m	B m ² /m
402.112 Z	0,550	0,062
402.115 Z	0,590	0,066
402.120 Z	0,680	0,074
402.125 Z	0,760	0,083
402.130 Z	0,850	0,092
402.135 Z	0,960	0,103
402.140 Z	1,045	0,112

Artikel-Nr.	G kg/m	B m ² /m
62.507	0,840	0,076
62.508	0,960	0,086
62.509	1,090	0,096

G = Gewicht
 B = Beschichtungsfläche

G = Poids
 B = Surface à traiter

G = Weight
 B = Coated surface

**Aluminium-Glasleisten
 (Länge 6 m)**

**Parcloses en aluminium
 (longueur 6 m)**

**Aluminium glazing beads
 (length 6 m)**

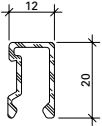

404.112

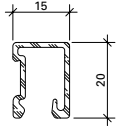

404.115

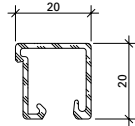

404.120

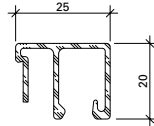

404.125

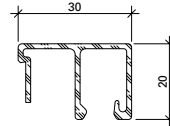

404.130

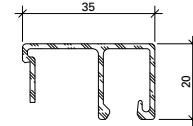

404.135

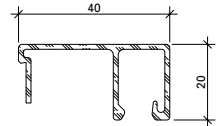

404.140

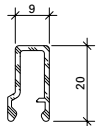

404.109

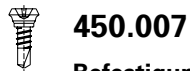

450.007

Befestigungsknopf

VE = 50 Magazine à 10 Knöpfe

Bouton de fixation

UV = 50 magasins à 10 pièces

Fastening stud

PU = 50 magazines with 10 studs



450.008

Befestigungsknopf

VE = 400 Magazine à 10 Knöpfe

Bouton de fixation

UV = 400 magasins à 10 pièces

Fastening stud

PU = 400 magazines with 10 studs



450.014

Befestigungsknopf

VE = 50 Magazine à 10 Knöpfe

Bouton de fixation

UV = 50 magasins à 10 pièces

Fastening stud

PU = 50 magazines with 10 studs

Artikel-Nr.	G kg/m	U m ² /m	P m ² /m
404.112	0,202	0,110	0,032
404.115	0,226	0,117	0,035
404.120	0,252	0,148	0,040
404.125	0,310	0,178	0,045
404.130	0,330	0,188	0,050
404.135	0,350	0,198	0,055
404.140	0,370	0,208	0,060
404.109	0,180	0,102	0,029

G = Gewicht
 U = Abwicklung umlaufend
 P = Polierabwicklung

G = Poids
 U = Périmètre extérieur
 P = Périmètre à polir

G = Weight
 U = Circumferential development
 P = Circumferential polishing



450.006

Befestigungsknopf (kurz) SR1

Bohrdurchmesser ø 3,5 mm

VE = 100 Stück

Bouton de fixation (court) SR1

Diamètre de perçage ø 3,5 mm

UV = 100 pièces

Fastening stud (short) SR1

Hole diameter ø 3,5 mm

PU = 100 pieces



499.001

Befestigungsset

zum Versetzen der
 magazinierten Befestigungs-
 Knöpfe 450.007/008

VE = 1 Set komplett inkl. Koffer
 3 Kreuzschlitz-
 Schraubklingen

499.001

**Machine à poser les boutons
 de parcloses**

pour le déplacement des
 boutons de fixations 450.007/008
 emmagasinés

UV = 1 set complet, valise incl.
 3 mèches cruciforme

499.001

Fastening set

for placing magazine fixing
 studs 450.007/008

PU = 1 set complete, incl. case
 3 Phillips screwdriver
 blades

Aluminium-Glasleisten
 (Länge 6 m)

Parcloses en aluminium
 (longueur 6 m)

Aluminium glazing beads
 (length 6 m)

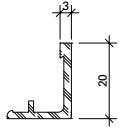

405.103

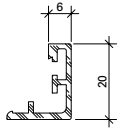

405.106

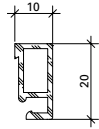

405.110

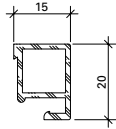

405.115

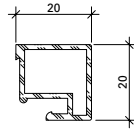

405.120

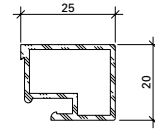

405.125

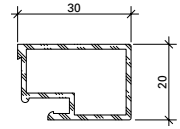

405.130

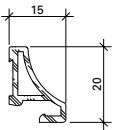

406.905

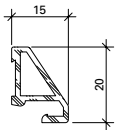

406.907

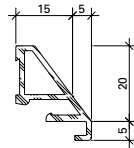

406.901

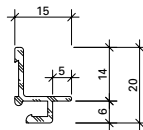

406.903

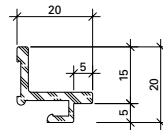

406.909

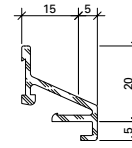

406.996



450.022

Befestigungsfeder

Edelstahl, inkl. Schraube,
 Bohrdurchmesser \varnothing 3,5 mm
 VE = 100 Stück

Ressort de fixation

acier Inox, vis inclus,
 diamètre de perçage \varnothing 3,5 mm
 UV = 100 pièces

Fixing spring

stainless steel, incl. screw,
 hole diameter \varnothing 3,5 mm
 PU = 100 pieces



450.020

Befestigungsknopf

Kunststoff
 VE = 100 Stück

Bouton de fixation

matière plastique
 UV = 100 pièces

Fastening stud

plastic
 PU = 100 pieces



450.021

Schraube M3x12

Stahl verzinkt,
 Bohrdurchmesser \varnothing 2,8 mm
 VE = 100 Stück

Vis M3x12

acier zingué,
 diamètre de perçage \varnothing 2,8 mm
 UV = 100 pièces

Screw M3x12

galvanised steel,
 hole diameter \varnothing 2,8 mm
 PU = 100 pieces

Artikel-Nr.	G kg/m	U m ² /m	P m ² /m
405.103	0,197	0,082	0,023
405.106	0,212	0,109	0,026
405.110	0,204	0,074	0,030
405.115	0,240	0,084	0,035
405.120	0,295	0,093	0,040
405.125	0,330	0,103	0,045
405.130	0,365	0,113	0,050
406.901	0,280	0,104	0,040
406.903	0,157	0,082	0,039
406.905	0,211	0,075	0,029
406.907	0,217	0,075	0,029
406.909	0,252	0,094	0,045
406.996	0,246	0,119	0,039

G = Gewicht
 U = Abwicklung umlaufend
 P = Polierabwicklung

G = Poids
 U = Périmètre extérieur
 P = Périmètre à polir

G = Weight
 U = Circumferential development
 P = Circumferential polishing



455.000

Fensterdichtung
EPDM, schwarz

VE = 100 m

455.000

Joint de fenêtre
EPDM, noir

UV = 100 m

455.000

Window weatherstrip
EPDM, black

PU = 100 m



455.046

Anschlagdichtung
EPDM, schwarz

VE = 100 m

455.046

Joint de butée
EPDM, noir

UV = 100 m

455.046

Rebate gasket
EPDM, black

PU = 100 m



455.201

Schwelldichtung
EPDM, schwarz,
Lappenlänge 14 mm

VE = 25 m

455.201

Joint de seuil
EPDM, noir,
longueur lèvres 14 mm

UV = 25 m

455.201

Threshold weatherstrip
EPDM, black,
lip length 14 mm

PU = 25 m

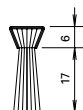

455.295 VE = 1 m

455.296 VE = 4,5 m

Bürste

Nylon, schwarz,
mit mittiger, dünner PE-Folie

455.295 UV = 1 m

455.296 UV = 4,5 m

Brosse

nylon, noir, avec film fin en PE
au centrée

455.295 PU = 1 m

455.296 PU = 4,5 m

Brush

nylon, black, with thin PE foil
in the centre



455.405

**Stulpdichtungsstück für
zweiflügelige Fenster**
aus Polyamid schwarz,
durch Metallbauer zu kürzen,
links und rechts verwendbar

Einsatz:

Im Stulpbereich beim
Standflügel unten und oben

VE = 20 Stück

455.405

**Embout d'étanchéité pour
fenêtre à deux vantaux**
en polyamide noir, à raccourcir
par le métallier, utilisable à à
gauche et à droite.

Utilisation:

Pour le fenêtres à deux vantaux
en haut et en bas

UV = 20 pièces

455.405

**Weatherstrip for double
vent windows**
made of black polyamide,
shortened by the metal fabrica-
tor, can be used left and right.

Usage:

Above and below of double
vent windows

PU = 20 pieces

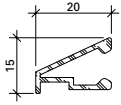

407.009

Wetterschenkel
Aluminium, roh

Gewicht 0,185 kg/m
U = 0,100 m²/m
P = 0,028 m²/m

Länge 6 m

Befestigungsknopf 450.006
Endstück 450.070

407.009

Renvoi d'eau
aluminium, brut

poids 0,185 kg/m
U = 0,100 m²/m
P = 0,028 m²/m

Longueur 6 m

Bouton de fixation 450.006
Embout 450.070

407.009

Weatherbar
aluminium, mill finish

weight 0,185 kg/m
U = 0,100 m²/m
P = 0,028 m²/m

Length 6 m

Fixing stud 450.006
End piece 450.070

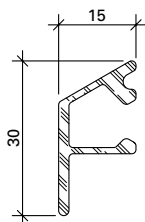

407.002

Wetterschenkel
Aluminium, roh

Gewicht 0,290 kg/m
U = 0,114 m²/m
P = 0,040 m²/m

Länge 6 m

Befestigungsknopf 450.006/007
Endstück 450.051

407.002

Renvoi d'eau
aluminium, brut

poids 0,290 kg/m
U = 0,114 m²/m
P = 0,040 m²/m

Longueur 6 m

Bouton de fixation 450.006/007
Embout 450.051

407.002

Weatherbar
aluminium, mill finish

weight 0,290 kg/m
U = 0,114 m²/m
P = 0,040 m²/m

Length 6 m

Fixing stud 450.006/007
End piece 450.051

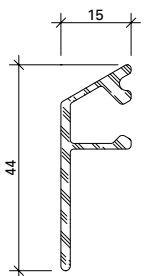

407.004

Wetterschenkel
Aluminium, roh

Gewicht 0,360 kg/m
U = 0,142 m²/m
P = 0,054 m²/m

Länge 6 m

Befestigungsknopf 450.006/007

407.004

Renvoi d'eau
aluminium, brut

poids 0,360 kg/m
U = 0,142 m²/m
P = 0,054 m²/m

Longueur 6 m

Bouton de fixation 450.006/007

407.004

Weatherbar
aluminium, mill finish

weight 0,360 kg/m
U = 0,142 m²/m
P = 0,054 m²/m

Length 6 m

Fixing stud 450.006/007

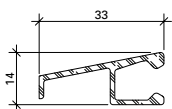

407.008

Wetterschenkel
Aluminium, roh

Gewicht 0,261 kg/m
U = 0,127 m²/m
P = 0,040 m²/m

Länge 6 m

Befestigungsknopf 450.006

407.008

Renvoi d'eau
aluminium, brut

poids 0,261 kg/m
U = 0,127 m²/m
P = 0,040 m²/m

Longueur 6 m

Bouton de fixation 450.006

407.008

Weatherbar
aluminium, mill finish

weight 0,261 kg/m
U = 0,127 m²/m
P = 0,040 m²/m

Length 6 m

Fixing stud 450.006



450.070

Endstück

Kunststoff schwarz,
für Wetterschenkel 407.009

VE = je 5 Stück
(links und rechts)

450.070

Embout

matière plastique, noire,
pour renvoi d'eau 407.009

UV = 5 paires
(gauche et droite)

450.070

End piece

black, plastic,
for weatherbar 407.009

PU = 5 pieces each
(left and right)



450.051

Endstück

Kunststoff schwarz,
für Wetterschenkel 407.002

VE = je 10 Stück
(links und rechts)

450.051

Embout

matière plastique noire,
pour renvoi d'eau 407.002

UV = 10 paires
(gauche et droite)

450.051

End piece

black plastic,
for weatherbar 407.002

PU = 10 pieces each
(left and right)

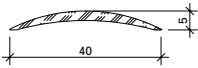

407.040

Schwelle

Aluminium, roh

Gewicht 0,200 kg/m

U = 0,084 m²/m

P = 0,043 m²/m

Länge 6 m

407.040

Seuil

aluminium brut

poids 0,200 kg/m

U = 0,084 m²/m

P = 0,043 m²/m

Longueur 6 m

407.040

Threshold

aluminium mill finish

weight 0,200 kg/m

U = 0,084 m²/m

P = 0,043 m²/m

Length 6 m

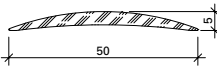

407.041

Schwelle

Aluminium, roh

Gewicht 0,325 kg/m

U = 0,104 m²/m

P = 0,053 m²/m

Länge 6 m

407.041

Seuil

aluminium brut

poids 0,325 kg/m

U = 0,104 m²/m

P = 0,053 m²/m

Longueur 6 m

407.041

Threshold

aluminium mill finish

weight 0,325 kg/m

U = 0,104 m²/m

P = 0,053 m²/m

Length 6 m

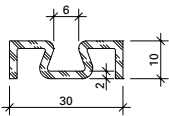

407.101

Zusatzprofil

Aluminium, roh

Gewicht 0,310 kg/m

U = 0,130 m²/m

P = 0,044 m²/m

Länge 6 m

407.101

Profilé complémentaire

aluminium brut

poids 0,310 kg/m

U = 0,130 m²/m

P = 0,044 m²/m

Longueur 6 m

407.101

Additional profile

aluminium mill finish

weight 0,310 kg/m

U = 0,130 m²/m

P = 0,044 m²/m

Length 6 m

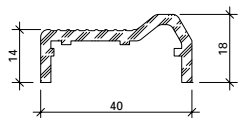

407.049

Türschwellerprofil
Aluminium, roh,
für behindertengerechte
Schwellenausbildung
nach DIN 18025

Gewicht 0,510 kg/m
U = 0,145 m²/m
P = 0,072 m²/m

Länge 6 m

Einsatz:
In Kombination mit
Anschlag-Dichtung 452.989

407.049

Profilé de seuil de porte
aluminium, brut, pour des
seuils adaptés à la circulation
des handicapés, conformément
à DIN 18025

Poids 0,510 kg/m
U = 0,145 m²/m
P = 0,072 m²/m

Longueur 6 m

Utilisation:
En combinaison avec joint
de butée 452.989

407.049

Door threshold profile
aluminium, mill finish, suitable
for handicapped compliant
threshold constructions
according to DIN 18025

Weight 0,510 kg/m
U = 0,145 m²/m
P = 0,072 m²/m

Length 6 m

Usage:
In combination with
rebate gasket 452.989

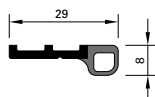

452.989

Anschlagdichtung
koextrudiert, ASA/TPE, schwarz

VE = 5 Stangen à 3 m

Einsatz:
In Kombination mit
Türschwellerprofil 407.049

452.989

Joint de butée
co-extrudé, ASA/TPE, noir

UV = 5 barres à 3 m

Utilisation:
En combinaison avec profilé
pour seuil de porte 407.049

452.989

Rebate gasket
co-extruded, ASA/TPE, black

PU = 5 bars, 3 m each

Usage:
In combination with door
threshold profile 407.049

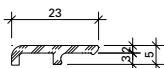

407.099

Zusatzprofil
Aluminium, roh

Gewicht 0,170 kg/m
U = 0,062 m²/m

Länge 6 m

407.099

Profilé complémentaire
aluminium brut

poids 0,170 kg/m
U = 0,062 m²/m

Longueur 6 m

407.099

Additional profile
aluminium mill finish

weight 0,170 kg/m
U = 0,062 m²/m

Length 6 m



407.123

Zusatzprofil
Aluminium, roh

Gewicht 0,159 kg/m
U = 0,056 m²/m

Länge 6 m

407.123

Profilé complémentaire
aluminium brut

poids 0,159 kg/m
U = 0,056 m²/m

Longueur 6 m

407.123

Additional profile
aluminium mill finish

weight 0,159 kg/m
U = 0,056 m²/m

Length 6 m

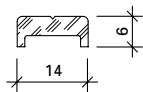

407.090

Zusatzprofil

Aluminium, roh,
für Flügelfalz-Entwässerung

Gewicht 0,161 kg/m
U = 0,044 m²/m

Länge 6 m

407.090

Profilé complémentaire

aluminium brut, pour
drainage feuillure de fenêtre

poids 0,161 kg/m
U = 0,044 m²/m

Longueur 6 m

407.090

Additional profile

aluminium mill finish,
for vent rebate drainage

weight 0,161 kg/m
U = 0,044 m²/m

Length 6 m

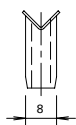

450.045

Wasserablauf-Tülle

Kupfer, vernickelt

VE = 100 Stück

450.045

Douille d'écoulement

cuire, nickelé

UV = 100 pièces

450.045

Draining pipe

copper, nickel-plated

PU = 100 pieces



499.103

Bohrlehre

für Wasserablauf-Tülle 450.045

VE = 1 Stück

499.103

Gabarit de perçage

pour douille d'écoulement
450.045

UV = 1 pièces

499.103

Drilling jig

for draining pipe 450.045

PU = 1 pieces



499.104

Setzwerkzeug

für Wasserablauffülle
450.045

VE = 1 Stück

499.104

Outil de pose

pour douille d'écoulement
450.045

UV = 1 pièce

99.104

Mounting tool

for draining pipe 450.045

PU = 1 piece



450.116

Kugelventil

Kunststoff schwarz, inkl. Verlängerungsröhrchen aus durchsichtigem Kunststoff, ø12,5 mm, Länge 50 mm, für verdecktliegende Glasfalz-Belüftung/Entwässerung bei Festverglasungen

VE = 20 Stück

450.116

Busette pare-tempête

matière plastique noire, incl. rallonge en tube plastique translucide, ø12,5 mm, longueur 50 mm, pour aération des feuillures à verre non apparente/drainage des vitrages fixes

UV = 20 pièces

450.116

Outdoor storme valve

plastic, black, incl. transparent plastic tube extension, ø 12,5 mm, length 50 mm, for glazing rebate ventilation/drainage of fixed glazings

PU = 20 pieces



450.110

Winkel für Glasfalzbelüftung

Kunststoff schwarz, verdeckt liegender Einbau, oben

VE = 20 Stück

450.110

Equerre pour aération des feuillures à verre

matière plastique noire, montage non apparente, en haut

UV = 20 pièces

450.110

Angle for glazing rebate ventilation

plastic, black, concealed installation, top

PU = 20 pieces

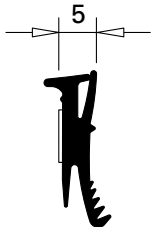

455.027

Glasdichtung

EPDM, schwarz,
für Profilanschlagseite,
selbstklebend, Fugenbreite 5 mm

Einsatz siehe Seiten 33/34

VE = 100 m

455.027

Joint de vitrage

EPDM, noir, pour côté
aile fixe, autocollant, largeur
du joint 5 mm

Utilisation voir pages 33/34

UV = 100 m

455.027

Glazing weatherstrip

EPDM, black, for section
flange, self-adhesive, joint
width 5 mm

Application see pages 33/34

PU = 100 m

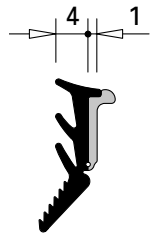

455.029

Glasdichtung mit Abreisssteg

EPDM, schwarz,
für Glasleistenseite

Einsatz siehe Seiten 33/34

VE = 100 m

455.029

Joint de vitrage avec partie déchirable

EPDM, noir,
pour côté parclose

Utilisation voir pages 33/34

UV = 100 m

455.029

Glazing weatherstrip with detachable strip

EPDM, black,
for glazing bead side

Application see pages 33/34

PU = 100 m

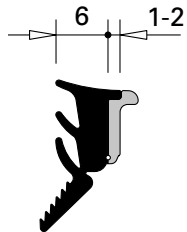

455.028

Glasdichtung mit Abreisssteg

EPDM, schwarz,
für Glasleistenseite

Einsatz siehe Seiten 33/34

VE = 100 m

455.028

Joint de vitrage avec partie déchirable

EPDM, noir,
pour côté parclose

Utilisation voir pages 33/34

UV = 100 m

455.028

Glazing weatherstrip with detachable strip

EPDM, black,
for glazing bead side

Application see pages 33/34

PU = 100 m

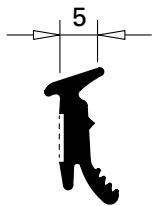

455.019

Glasdichtung

aus EPDM, schwarz,
für Profilanschlagseite,
selbstklebend, Fugenbreite 5 mm

VE = 100 m

455.019

Joint de vitrage

en EPDM, noir,
pour côté battue, autocollant,
pour largeur du joint 5 mm

UV = 100 m

455.019

Glazing weatherstrip

EPDM, black,
for section flange,
self-adhesive, joint width 5 mm

PU = 100 m



450.030 9 x 4 mm
450.031 9 x 5 mm
450.032 9 x 6 mm
450.034 9 x 8 mm
450.035 14 x 4 mm
450.036 14 x 5 mm
450.037 14 x 6 mm

Distanzband
Zellpolyethylen,
geschlossen, weiss,
selbstklebend

Einsatz siehe Seiten 35-39

VE = 50 m

450.030 9 x 4 mm
450.031 9 x 5 mm
450.032 9 x 6 mm
450.034 9 x 8 mm
450.035 14 x 4 mm
450.036 14 x 5 mm
450.037 14 x 6 mm

Bande d'écartement
polyéthylène cellulaire,
à cellules fermées, blanche,
auto-adhésive

Utilisation voir pages 35-39

UV = 50 m

450.030 9 x 4 mm
450.031 9 x 5 mm
450.032 9 x 6 mm
450.034 9 x 8 mm
450.035 14 x 4 mm
450.036 14 x 5 mm
450.037 14 x 6 mm

Packing tape
closed cell polyethylene,
white, self-adhesive

Application see pages 35-39

PU = 50 m



450.060 9 x 4 mm
450.061 9 x 5 mm
450.062 9 x 6 mm
450.064 9 x 8 mm

Distanzband
Zellpolyethylen,
geschlossen, schwarz,
selbstklebend

Einsatz siehe Seiten 35-39

VE = 50 m

450.060 9 x 4 mm
450.061 9 x 5 mm
450.062 9 x 6 mm
450.064 9 x 8 mm

Bande d'écartement
polyéthylène cellulaire,
à cellules fermées, noire,
auto-adhésive

Utilisation voir pages 35-39

UV = 50 m

450.060 9 x 4 mm
450.061 9 x 5 mm
450.062 9 x 6 mm
450.064 9 x 8 mm

Packing tape
closed cell polyethylene,
black, self-adhesive

Application see pages 35-39

PU = 50 m



450.091

Reiniger

zur Reinigung aller Teile vor dem Anbringen der Dichtmasse 450.092

VE = 1 Liter

450.091

Nettoyant

pour nettoyer toutes les pièces avant d'appliquer la pâte à étancher 450.092

UV = 1 litre

450.091

Cleaner

for cleaning all components before applying the sealing compound 450.092

PU = 1 litre



450.092

Kleb- und Dichtmasse

schwarz, für das Abdichten der Dichtungs-Stösse und -Durchbrüche

VE = 1 Kartusche 290 ml

Wichtig:

Ohne Vorbehandlung mit Reiniger 450.091 ist die Klebhaftung nicht gewährleistet.

450.092

Pâte à coller et à étancher

noire, pour étancher les raccords et les points de raccords des joints intérieurs

UV = 1 cartouche 290 ml

Important:

Sans traitement préliminaire avec un nettoyant 450.091, l'adhésion n'est pas garantie.

450.092

Sealing and bonding compound

black, for sealing the joints and holes in the weatherstrip

PU = 1 cartridge 290 ml

Important:

Adhesion cannot be guaranteed unless cleaner 450.091 has been used as a pre-treatment.



450.106

Dichtmasse

transparent, Silikon dünnflüssig, für Abdichtungen von kleinen Fugen, inkl. Ausspritzdüsen

VE = 2 Kartuschen 310 ml

450.106

Pâte d'étanchéité

transparente, silicone fluide, pour étanchéification de petits joints, avec gicleurs d'éjection

UV = 2 cartouches de 310 ml

450.106

Sealing compound

transparent, thin silicone, for sealing small joints, includes spray nozzles

PU = 2 cartridges 310 ml



450.093

Fliessfett

für die Schmierung der Jansen-Anschweissbänder

VE = 1 Flasche à 500 g
2 Dosierflaschen

450.093

Graisse fluide

pour le graissage des paumelles à souder Jansen

UV = 1 flacon de 500 g
2 flacons doseurs

450.093

Lubrication

for lubricating Jansen weld-on hinges

PU = 1 bottle each 500 g
2 dosing bottles



450.089

Spezialkleber

farblos, schnell härtend, klebt Kunststoffe und Gummi

VE = 1 Dose à 20 g

450.089

Colle spéciale

incolore, à durcissement rapide, pour matières plastiques et caoutchouc

UV = 1 boîte à 20 g

450.089

Special adhesive

colourless, fast-curing, bonds plastics and rubber

PU = 1 x 20 g can

Verglasungstabelle Trockenverglasung

Tableau de vitrage à sec

Glazing table dry glazing

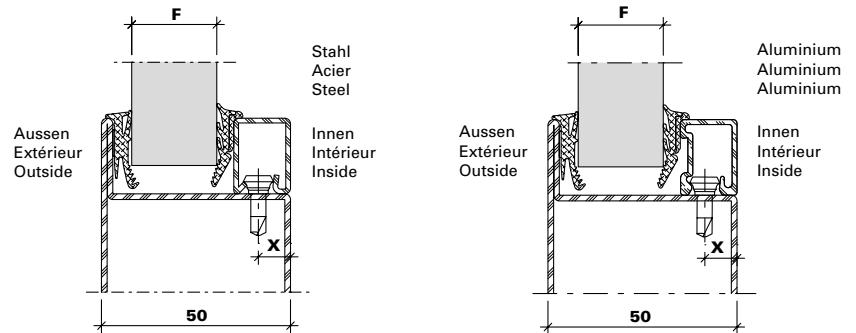

Dichtung Joint Weatherstrip	Aussen Extérieur Outside	Innen Intérieur Inside					X	Glasleisten Parcloses Glazing beads	Stahl Acier Steel	Aluminium Aluminium Aluminium	
	455.027	455.028	455.028	455.028	455.029	455.029					
Verglasung F Vitrage F Glazing F	5		5	6	7	8	9		402.130 Z		404.130 Z
		9	10	11	12	13	9		402.125 Z		404.125 Z
		14	15	16	17	18	9		402.120 Z		404.120 Z
		19	20	21	22	23	9		402.115 Z		404.115 Z
				24	25	26	7		402.112 Z		404.112 Z

Marché France:
 Conforme au DTU 39

Hinweise Verglasungsvarianten
 siehe Seite 40

Remarques variantes de vitrage
 voir page 40

Notices alternative glazings
 see page 40

Verglasungstabelle Trockenverglasung
 mit um 3 mm versetzter Glasleiste

Tableau de vitrage à sec
 avec parcloze décalable de 3 mm

Glazing table dry glazing
 with glazing bead offset by 3 mm

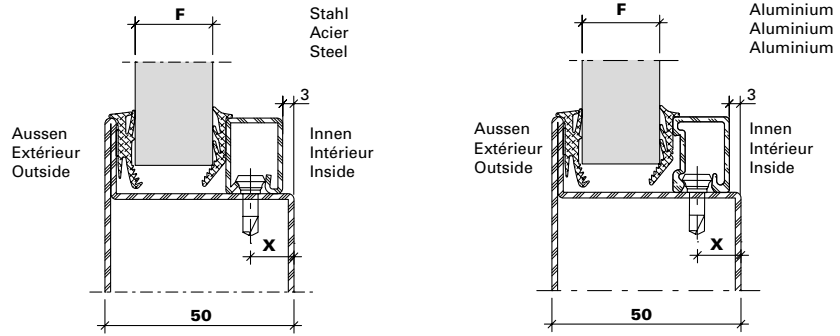

Dichtung Joint Weatherstrip	Aussen Extérieur Outside	Innen Intérieur Inside					X	Glasleisten Parcloses Glazing beads	Aluminium Aluminium Aluminium
	455.027	455.028	455.028	455.028	455.029	455.029			
Verglasung F Vitrage F Glazing F	5					5	12	402.130 Z	404.130 Z
		6	7	8	9	10	12	402.125 Z	404.125 Z
		11	12	13	14	15	12	402.120 Z	404.120 Z
		16	17	18	19	20	12	402.115 Z	404.115 Z
				21	22	23	10	402.112 Z	404.112 Z

Marché France:
 Conforme au DTU 39

Hinweise Verglasungsvarianten
 siehe Seite 40

Remarques variantes de vitrage
 voir page 40

Notices alternative glazings
 see page 40

Verglasungstabelle mit Distanzband
 (Nassverglasung)

Tableau de vitrage avec bande d'écartement
 (Vitrage à mastic)

Glazing table with packing tape
 (Glazing with sealing)

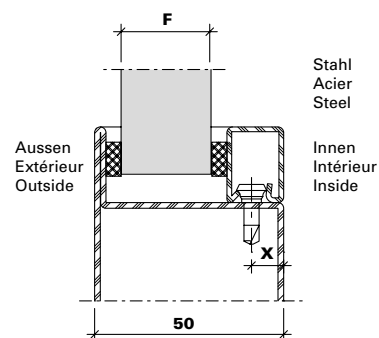

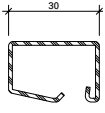
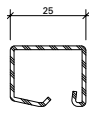
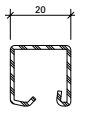
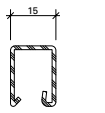
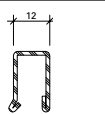
Fugenbreite (mm) Largeur du joint (mm) Width of joint (mm)	Aussen Extérieur Outside	Innen Intérieur Inside	Aussen Extérieur Outside	Innen Intérieur Inside	Aussen Extérieur Outside	Innen Intérieur Inside	Aussen Extérieur Outside	Innen Intérieur Inside	Aussen Extérieur Outside	Innen Intérieur Inside	X	Glasleisten Parcloles Glazing beads
	450.032 450.062	450.032 450.062	450.032 450.062	450.031 450.061	450.031 450.061	450.031 450.061	450.031 450.061	450.031 450.061	450.030 450.060	450.030 450.060		
	6	6	6	5	5	5	5	4	4	4		Stahl Acier Steel
Verglasung F Vitrage F Glazing F	5		6		7		8		9		9	 402.130 Z
	10		11		12		13		14		9	 402.125 Z
	15		16		17		18		19		9	 402.120 Z
	20		21		22		23		24		9	 402.115 Z
					25		26		27		7	 402.112 Z

Marché France:
 Conforme au DTU 39

Hinweise Verglasungsvarianten
 siehe Seite 40

Remarques variantes de vitrage
 voir page 40

Notices alternative glazings
 see page 40

Verglasungstabelle mit Distanzband
 mit um 3 mm versetzter Glasleiste
 (Nassverglasung)

Tableau de vitrage avec bande d'écartement
 avec parclose décalable de 3 mm
 (Vitrage à mastic)

Glazing table with packing tape
 with glazing bead offset by 3 mm
 (Glazing with sealing)

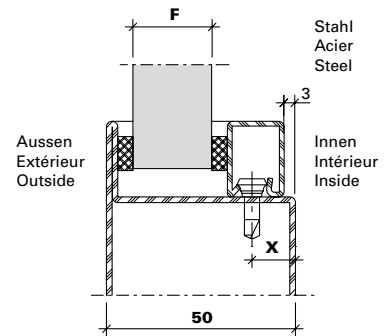

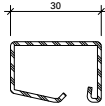
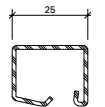
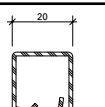
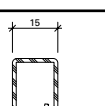
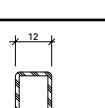
Fugenbreite (mm) Largeur du joint (mm) Width of joint (mm)	Aussen Extérieur Outside	Innen Intérieur Inside	Aussen Extérieur Outside	Innen Intérieur Inside	Aussen Extérieur Outside	Innen Intérieur Inside	Aussen Extérieur Outside	Innen Intérieur Inside	Aussen Extérieur Outside	Innen Intérieur Inside	X	Stahl Acier Steel
	450.032 450.062	450.032 450.062	450.032 450.062	450.031 450.061	450.031 450.0621	450.031 450.061	450.031 450.061	450.031 450.061	450.030 450.060	450.030 450.060		
	6	6	6	5	5	5	5	4	4	4		
Verglasung F Vitrage F Glazing F							5		6		12	 402.130 Z
	7	8	9	10	11	12					12	 402.125 Z
	12	13	14	15	16	12					12	 402.120 Z
	17	18	19	20	21	12					12	 402.115 Z
			22	23	24	10					10	 402.112 Z

Marché France:
 Conforme au DTU 39

Hinweise Verglasungsvarianten
 siehe Seite 40

Remarques variantes de vitrage
 voir page 40

Notices alternative glazings
 see page 40

Verglasungstabelle mit Distanzband
 (Nassverglasung)

Tableau de vitrage avec bande d'écartement
 (Vitrage à mastic)

Glazing table with packing tape
 (Glazing with sealing)

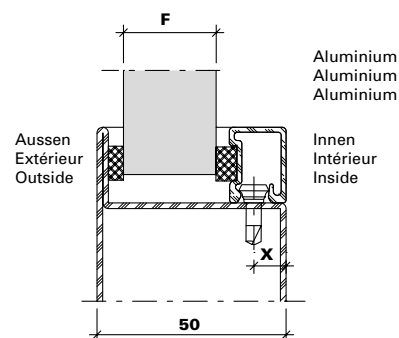

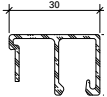
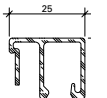
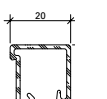
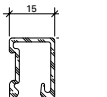
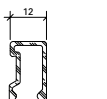
Fugenbreite (mm) Largeur du joint (mm) Width of joint (mm)	Aussen Extérieur Outside	Innen Intérieur Inside	Aussen Extérieur Outside	Innen Intérieur Inside	Aussen Extérieur Outside	Innen Intérieur Inside	Aussen Extérieur Outside	Innen Intérieur Inside	Aussen Extérieur Outside	Innen Intérieur Inside	X	Glasleisten Parcloles Glazing beads
	450.032 450.062	450.034 450.064	450.031 450.061	450.034 450.064	450.032 450.062	450.034 450.064	450.031 450.061	450.032 450.062	450.030 450.060	450.032 450.062		
	6	6	5	6	6	4	5	4	4	4		Aluminium Aluminium Aluminium
Verglasung F Vitrage F Glazing F	5		6		7		8		9		9	 404.130
	10		11		12		13		14		9	 404.125
	15		16		17		18		20		9	 404.120
	20		21		22		23		24		9	 404.115
					25		26		27		7	 404.112

Marché France:
 Conforme au DTU 39

Hinweise Verglasungsvarianten
 siehe Seite 40

Remarques variantes de vitrage
 voir page 40

Notices alternative glazings
 see page 40

Verglasungstabelle mit Distanzband
 mit um 3 mm versetzter Glasleiste
 (Nassverglasung)

Tableau de vitrage avec bande d'écartement
 avec parclose décalable de 3 mm
 (Vitrage à mastic)

Glazing table with packing tape
 with glazing bead offset by 3 mm
 (Glazing with sealing)

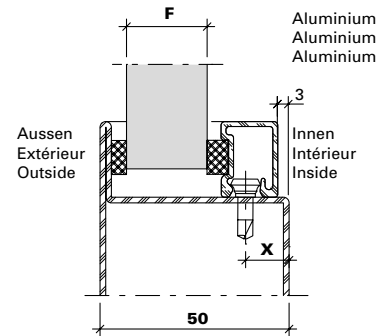

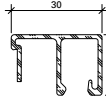
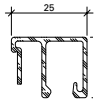
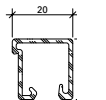
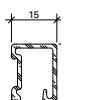
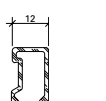
Fugenbreite (mm) Largeur du joint (mm) Width of joint (mm)	Aussen Extérieur Outside	Innen Intérieur Inside	Aussen Extérieur Outside	Innen Intérieur Inside	Aussen Extérieur Outside	Innen Intérieur Inside	Aussen Extérieur Outside	Innen Intérieur Inside	Aussen Extérieur Outside	Innen Intérieur Inside	X	Glasleisten Parcloses Glazing beads Aluminium Aluminium Aluminium
	450.032 450.062	450.034 450.064	450.031 450.061	450.034 450.064	450.032 450.062	450.034 450.064	450.031 450.061	450.032 450.062	450.030 450.060	450.032 450.062		
	6	6	5	6	6	4	5	4	4	4		
Verglasung F Vitrage F Glazing F							5		6		12	 404.130
	7	8		9		10		11		12	 404.125	
	12	13		14		15		16		12	 404.120	
	17	18		19		20		21		12	 404.115	
				22		23		24		10	 404.112	

Marché France:
 Conforme au DTU 39

Verglasungstabelle mit Distanzband
 (Nassverglasung)

Tableau de vitrage avec bande d'écartement
 (vitrage à mastic)

Glazing table with packing tape
 (glazing with sealing)

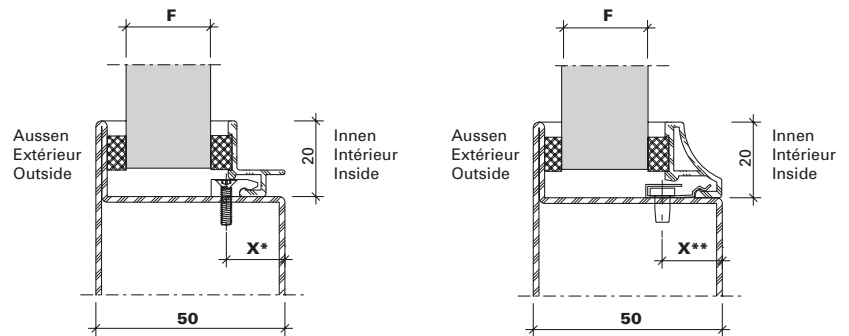

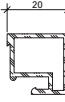
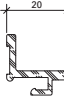
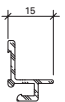
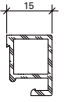
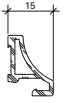
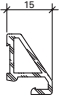
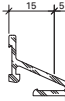
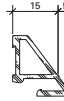
Fugenbreite (mm) Largeur du joint (mm) Width of joint (mm)	Aussen Extérieur Outside	Innen Intérieur Inside	Aussen Extérieur Outside	Innen Intérieur Inside	Aussen Extérieur Outside	Innen Intérieur Inside	Aussen Extérieur Outside	Innen Intérieur Inside	Aussen Extérieur Outside	Innen Intérieur Inside	X	Glasleisten Parcloses Glazing beads	
	450.031	450.034	450.032	450.032	450.031	450.032	450.031	450.031	450.030	450.031			
	450.061	450.064	450.062	450.062	450.061	450.062	450.061	450.061	450.060	450.061			
Verglasung F Vitrage F Glazing F	15		16		17		18		19		16** 21**	 405.120	 406.909
	20		21		22		23		24			16* 21**	 406.903
	20		21		22		23		24		11* 16**	 404.120	
	20		21		22		23		24			 406.905	 406.905
	20		21		22		23		24			 406.996	 406.901
	20		21		22		23		24				

Marché France:
 Conforme au DTU 39

* Bohrabstand für Knopf 450.020
 ** Bohrabstand für Feder 450.022

* Distance de perçage pour bouton 450.020
 ** Distance de perçage pour ressort 450.022

* Drilling distance for stud 450.020
 ** Drilling distance for spring 450.022

Diese Glasleisten sind nur in Verbindung mit Nassverglasung (Silikon-Versiegelung) geeignet.

Ces parcloses ne conviennent que dans le cas d'un vitrage à mastic.

These glazing beads are suitable only for use with glazing with sealing.

**Wichtiger Hinweis:
Trockenverglasung**

Grundlage der Verglasungstabelle sind die Nennmasse der Profile und Füllelemente. Bedingt durch verschiedene Toleranzen (Profile, Glasleisten, Anordnung Befestigungsknöpfe, Glasdichtungen und Glaselemente) empfehlen wir, die Wahl der inneren Glasdichtungen vorgängig an einem Element zu prüfen.

Gegebenenfalls kommt die nächst kleinere oder grössere Glasleiste/Dichtung zur Anwendung.

Die Masse X entsprechen ungefähr einer rahmenbündigen, resp. um 3 mm versetzten Glasleisten-Montage.

Wir empfehlen, die Glasleisten nur auf der Raumseite anzuwenden.

**Wichtiger Hinweis:
Nassverglasung**

Grundlage der Verglasungstabelle sind die Nennmasse der Profile und Füllelemente. Bedingt durch verschiedene Toleranzen (Profile, Glasleisten, Anordnung Befestigungsknöpfe und Glaselemente) empfehlen wir, die Wahl der inneren Distanzbänder vorgängig an einem Element zu prüfen. Gegebenenfalls kommt die nächst kleinere oder grössere Glasleiste/Distanzband zur Anwendung.

Die Masse X entsprechen ungefähr einer rahmenbündigen, resp. um 3 mm versetzten Glasleisten-Montage.

Wir empfehlen, die Glasleisten nur auf der Raumseite anzuwenden.

Betreffend Fugendimensionierung und Fugenausbildung verweisen wir auf die Richtlinien der Glashersteller.

**Remarque importante:
Vitrage à sec**

Les cotes nominales des profilés et des éléments de remplissage sont la base du tableau de vitrage. A cause des différentes tolérances (profilés, parclozes, disposition boutons de fixation, bandes de distance et éléments vitrés) nous recommandons d'effectuer un essai préalable avec le joint intérieur choisi sur un élément. Le cas échéant, utiliser la parclose / le joint de la taille inférieure ou supérieure.

Les cotes X correspondent environ à un montage de parclose affleurant au cadre et décalé de 3 mm.

Nous recommandons de n'utiliser les parclozes que du côté intérieur.

**Remarque importante:
Vitrage à mastic**

Les cotes nominales des profilés et des éléments de remplissage sont la base du tableau de vitrage. A cause des différentes tolérances (profilés, parclozes, disposition boutons de fixation et éléments vitrés) nous recommandons d'effectuer un essai préalable avec la bande d'écartement choisie sur un élément. Le cas échéant, utiliser la parclose / la bande d'écartement de la taille inférieure ou supérieure.

Les cotes X correspondent environ à un montage de parclose affleurant au cadre et décalé de 3 mm.

Nous recommandons de n'utiliser les parclozes que du côté intérieur.

En ce qui concerne le dimensionnement et la formation des joints nous renvoyons aux directives du fabricant de verre.

**Important notice:
Dry glazing**

The glazing table is based on the nominal dimensions of the profiles and infill panels. Owing to variations in the tolerances (profiled sections, glazing beads, layout of fastening studs, glazing seals and glazing) it is advisable to check your choice of inside glazing seals on an infill panel beforehand. If necessary the next smaller or larger size glazing bead/weatherstrip can be used.

Dimensions X approximately correspond to a glazing bead installation that is flush with the frame or offset by 3 mm.

We recommend fitting the glazing beads on the room-side only.

**Important notice:
Glazing with sealing**

The glazing table is based on the nominal dimensions of the profiles and infill panels. Owing to variations in the tolerances (profiled sections, glazing beads, layout of fastening studs and glazing) it is advisable to check your choice of inside packing tapes on an infill panel beforehand. If necessary the next smaller or larger size glazing bead/packing tape can be used.

Dimensions X approximately correspond to a glazing bead installation that is flush with the frame or offset by 3 mm.

We recommend fitting the glazing beads on the room-side only.

Referring to joint dimensioning and joint form we refer you to the guidelines of glass manufacturer.

Aufgesetzter Fensterbeschlag

Ferrure de fenêtre plaquée

Surface-mounted window fitting



557.251

Dreholive

Aluminium-Druckguss, schwarz, für aufgesetzten Fensterbeschlag, inkl. Montageplatte Stahl roh und Befestigungsschrauben

VE = 1 Stück

557.251

Bouton rotatif

moulage d'aluminium sous pression, noir, pour ferrure de fenêtre plaquée, avec plaque de montage en acier brut et vis de fixation

UV = 1 pièce

557.251

Olive handle

die-cast aluminium, black, for surface-mounted window fittings, includes mounting plate, mill finish steel, and fixing screws

PU = 1 piece



557.252

Dreholive

Aluminium-Druckguss, Bronze, für aufgesetzten Fensterbeschlag, inkl. Montageplatte Stahl roh und Befestigungsschrauben

VE = 1 Stück

557.252

Bouton rotatif

moulage d'aluminium sous pression, bronze, pour ferrure de fenêtre plaquée, avec plaque de montage en acier brut et vis de fixation

UV = 1 pièce

557.252

Olive handle

die-cast aluminium, bronze, for surface-mounted window fittings, includes mounting plate, mill finish steel, and fixing screws

PU = 1 piece



557.253

Schliessstück für einflügelige Fenster

Aluminium-Druckguss, schwarz, für aufgesetzten Fensterbeschlag, inkl. Montageplatte Stahl roh, Aluminium-Distanzstück (9,5 mm) und Befestigungsschrauben

VE = 2 Garnituren

557.253

Pièce de fermeture pour fenêtres à un vantail

moulage d'aluminium sous pression, noir, pour ferrure de fenêtre plaquée, avec plaque de montage en acier brut, pièce intercalaire en aluminium (9,5 mm) et vis de fixation

UV = 2 garnitures

557.253

Locking component for single-vent windows

die-cast aluminium, black, for surface-mounted window fittings, includes mounting plate, mill finish steel, aluminium spacer (9,5 mm) and fixing screws

PU = 2 kits



557.254

Schliessstück für einflügelige Fenster

Aluminium-Druckguss, Bronze, für aufgesetzten Fensterbeschlag, inkl. Montageplatte Stahl roh, Aluminium-Distanzstück (9,5 mm) und Befestigungsschrauben

VE = 2 Garnituren

557.254

Pièce de fermeture pour fenêtres à un vantail

moulage d'aluminium sous pression, bronze, pour ferrure de fenêtre plaquée, avec plaque de montage en acier brut, pièce intercalaire en aluminium (9,5 mm) et vis de fixation

UV = 2 garnitures

557.254

Locking component for single-vent windows

die-cast aluminium, bronze, for surface-mounted window fittings, includes mounting plate, mill finish steel, aluminium spacer (9,5 mm) and fixing screws

PU = 2 kits



557.255

Mittelführung

Aluminium-Druckguss, schwarz, für aufgesetzten Fensterbeschlag, inkl. Montageplatte Stahl roh und Befestigungsschrauben

VE = 2 Garnituren

557.255

Guide central

moulage d'aluminium sous pression, noir, pour ferrure de fenêtre plaquée, avec plaque de montage en acier brut et vis de fixation

UV = 2 garnitures

557.255

Centre guide

die-cast aluminium, black, for surface-mounted window fittings, includes mounting plate, mill finish steel, and fixing screws

PU = 2 kits



557.256

Mittelführung

Aluminium-Druckguss, Bronze, für aufgesetzten Fensterbeschlag, inkl. Montageplatte Stahl roh und Befestigungsschrauben

VE = 2 Garnituren

557.256

Guide central

moulage d'aluminium sous pression, bronze, pour ferrure de fenêtre plaquée, avec plaque de montage en acier brut et vis de fixation

UV = 2 garnitures

557.256

Centre guide

die-cast aluminium, bronze, for surface-mounted window fittings, includes mounting plate, mill finish steel, and fixing screws

PU = 2 kits



557.257

Distanzstück für zweiflügelige Fenster

Aluminium, schwarz (16,5 mm), für Schliessstück 557.253/557.259, für aufgesetzten Fensterbeschlag, inkl. Befestigungsschrauben

VE = 2 Stück

557.257

Pièce intercalaire pour fenêtres à deux vantaux

aluminium, noir (16,5 mm), pour pièce de fermeture 557.253/557.259, pour ferrure de fenêtre plaquée, avec vis de fixation

UV = 2 pièces

557.257

Spacer for double-vent windows

aluminium, black (16,5 mm), for locking component 557.253/557.259, for surface-mounted window fittings, includes fixing screws

PU = 2 pieces



557.258

Distanzstück für zweiflügelige Fenster

Aluminium, Bronze (16,5 mm), für Schliessstück 557.254, für aufgesetzten Fensterbeschlag, inkl. Befestigungsschrauben

VE = 2 Stück

557.258

Pièce intercalaire pour fenêtres à deux vantaux

aluminium, bronze (16,5 mm), pour pièce de fermeture 557.254, pour ferrure de fenêtre plaquée, avec vis de fixation

UV = 2 pièces

557.258

Spacer for double-vent windows

aluminium, bronze (16,5 mm), for locking component 557.254, for surface-mounted window fittings, includes fixing screws

PU = 2 pieces



557.259

Spezial-Schliessstück für einflügelige Fenster

Aluminium-Druckguss, schwarz,
mit integriertem Flügelandruck
beim Schliessvorgang, für
aufgesetzten Beschlag, inkl.
Aluminium-Distanzstück
(9,5 mm) und Befestigungs-
schrauben

VE = 2 Garnituren

Für zweiflügelige Fenster zusätzlich bestellen:

557.257 Distanzstück
(16,5 mm)

557.259

Pièce de fermeture spéciale pour fenêtres à un vantail

moulage d'aluminium sous
pression, noir, avec compression
du vantail intégrée lors de la
fermeture, pour ferrure plaquée,
avec pièce intercalaire en
aluminium (9,5 mm) et vis de
fixation

UV = 2 garnitures

Pour fenêtres à deux vantaux commander séparément:

557.257 Pièce intercalaire
(16,5 mm)

557.259

Special locking component for single-vent windows

die-cast aluminium, black, with
integrated vent closing pressure
for closing, for surface-mounted
fittings, includes aluminium
spacer (9,5 mm) and fixing
screws

PU = 2 kits

For double-vent windows order separately:

557.257 Spacer
(16,5 mm)



557.260

Anschweislasche

Stahl roh, als Montageplatte bei aufgesetztem Fensterbeschlag für die Schliessstücke 557.253/557.254 und 557.259, bei Einsatz von schmalen Rahmen- resp. Riegelprofilen

VE = 1 Stück

557.260

Languette à souder

acier brut, sert de plaque de montage à la ferrure de fenêtre plaquée pour les pièces de fermeture 557.253/557.254 et 557.259 quand de fins profilés de cadre ou de traverse sont utilisés

UV = 1 pièce

557.260

Weld-on fixing bracket

steel, mill finish, as a mounting plate for surface-mounted window fittings for locking components 557.253/557.254 and 557.259, for use with narrow frame/transom profiles

PU = 1 piece



557.261

Anschweiss-Schliessstück

Stahl roh, als Variante für aufgesetzten Fensterbeschlag, bei Einsatz von schmalen Rahmen- resp. Riegelprofilen

VE = 1 Stück

557.261

Pièce de fermeture à souder

acier brut, variante de la ferrure de fenêtre plaquée, quand de fins profilés de cadre ou de traverse sont utilisés

UV = 1 pièce

557.261

Weld-on locking component

Steel, mill finish, as an option for surface-mounted window fittings, for use with narrow frame/transom profiles

PU = 1 piece



557.262 Stahl roh

557.263 Stahl schwarz

Verschlussstange

Länge 1600 mm, für aufgesetzten Beschlag

VE = 1 Stück

557.262 acier brut

557.263 acier noir

Barre de fermeture

longueur 1600 mm, pour ferrure plaquée

UV = 1 pièce

557.262 steel mill finish

557.263 steel black

Closing bar

length 1600 mm, for surface-mounted fittings

PU = 1 piece



557.264

Verschlussstange

Bronze, Länge 1300 mm, für aufgesetzten Beschlag

VE = 1 Stück

557.264

Barre de fermeture

bronze, longueur 1300 mm, pour ferrure plaquée

UV = 1 pièce

557.264

Closing bar

bronze, length 1300 mm, for surface-mounted fittings

PU = 1 piece

Verdeckt liegender Fensterbeschlag

Ferrure de fenêtre non apparente

Concealed window fitting



557.185

Fenstergriff

Zinkdruckguss vernickelt,
inkl. Befestigungsmaterial
und Dichtungsunterlage

Höhe: 143 mm
Tiefe: 43 mm

VE = 1 Stück

557.185

Poignée de fenêtre

fonte de zinc injectée,
nickelée, avec matériel de
fixation et support de joint

Hauteur: 143 mm
Profondeur: 43 mm

UV = 1 pièce

557.185

Window handle

zinc diecasting, nickel-plated,
including fixing materials
and weatherstrip support

Height: 143 mm
Depth: 43 mm

PU = 1 piece



557.184

Fenstergriff

Zinkdruckguss vernickelt,
inkl. Befestigungsmaterial
und Dichtungsunterlage

Höhe: 156 mm
Tiefe: 50 mm

VE = 1 Stück

557.184

Poignée de fenêtre

fonte de zinc injectée,
nickelée, avec matériel de
fixation et support de joint

Hauteur: 156 mm
Profondeur: 50 mm

UV = 1 pièce

557.184

Window handle

zinc diecasting, nickel-plated,
including fixing materials
and weatherstrip support

Height: 156 mm
Depth: 50 mm

PU = 1 piece



557.290

Fensterverriegelung mittig

Riegelstangen-Führungsstücke
in Edelstahl, Riegelstangen in
Aluminium schwarz anodisiert,
mit 2 Verschlusszapfen,
Anpressdruck verstellbar

VE = 1 Stück

Zusätzlich bestellen:

Senkkopfschrauben M5x10

557.290

Verrouillage de fenêtre central

pièces de guidage des barres de
verrouillage en acier inox, barres
de verrouillage en aluminium
noir anodisé, avec 2 bouchons,
pression d'appui réglable

UV = 1 pièce

Commander séparément:

Vis à tête fraisée M5x10

557.290

Window lock, centre

stainless steel locking bar guide
pieces, aluminium locking bars,
black anodised, with 2 sealing
studs, adjustable contact
pressure

PU = 1 piece

Order separately:

Countersunk head screws M5x10



557.292

Griffmitnehmer einflügelig
Zinkdruckguss, schwarz
Breite 36 mm

VE = 1 Stück

Zusätzlich bestellen:
557.164 Schrauben

557.292

**Entraîneur de poignée
pour un vantail**
fonte de zinc injectée,
noir, largeur 36 mm

UV = 1 pièce

Commander séparément:
557.164 Vis

557.292

Handle driver, single-vent
zinc diecasting, black,
width 36 mm

PU = 1 piece

Order separately:
557.164 Screws



557.186

Griffmitnehmer zweiflügelig
Zinkdruckguss, schwarz
Breite 30 mm

VE = 1 Stück

Zusätzlich bestellen:
557.164 Schrauben

557.186

**Entraîneur de poignée
pour deux vantaux**
fonte de zinc injectée,
noir, largeur 30 mm

UV = 1 pièce

Commander séparément:
557.164 Vis

557.186

Handle driver, double-vent
zinc diecasting, black,
width 30 mm

PU = 1 piece

Order separately:
557.164 Screws



557.291

**Verlängerung
Fensterverriegelung**
oben/unten, verdeckt liegend,
Riegelstangen-Führungsteil
in Edelstahl, Riegelstange
in Aluminium schwarz
anodisiert, Länge 900 mm,
mit Verschlusszapfen,
Anpressdruck verstellbar,
inkl. Verbindungsstück

VE = 1 Stück

Zusätzlich bestellen:
557.164 Schrauben
Senkkopfschrauben M5x10

557.291

**Rallonge verrouillage
de fenêtre**
haut/bas, non apparent, pièce
de guidage de la barre de
verrouillage en acier inox, tige
de verrouillage en aluminium
noir anodisé, longueur 900 mm,
avec bouchon, pression d'appui
réglable, avec pièce de jonction

UV = 1 pièce

Commander séparément:
557.164 Vis
Vis à tête fraisée M5x10

557.291

Extension for window lock
top/bottom, concealed, stainless
steel locking bar guide piece,
aluminium locking bar, black
anodised, length 900 mm, with
sealing stud, adjustable contact
pressure, includes connecting
piece

PU = 1 piece

Order separately:
557.164 Screws
Countersunk head screws M5x10



557.293

Schliessblech
Edelstahl, schwarz

VE = 5 Stück

Zusätzlich bestellen:
Senkkopfschrauben M5x10

557.293

Gâche de fermeture
acier Inox, noir

UV = 5 pièces

Commander séparément:
Vis à tête fraisée M5x10

557.293

Striking plate
stainless steel, black

PU = 5 pieces

Order separately:
Countersunk head screws M5x10

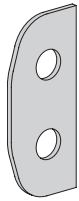

557.307

Schliessblech-Unterlage
Edelstahl, als Toleranzausgleich
bei Schliessblech 557.293

VE = 5 Stück 0,5 mm
5 Stück 1 mm

557.307

Cale de compensation
acier Inox, servant à compenser
les tolérances de la gâche de
fermeture 557.293

UV = 5 pièces 0,5 mm
5 pièces 1 mm

557.307

Base plate
stainless steel, as tolerance
equalisation for striking plate
557.293

PU = 5 pieces 0,5 mm
5 pieces 1 mm



557.079

Auflaufbock
Kunststoff schwarz,
für ein- und zweiflügelige
Drehfenster (durch
Metallbauer zu ändern)

VE = 10 Stück

Zusätzlich bestellen:
557.162 Schrauben

557.079

Bloc d'arrêt
matière plastique, noir,
pour fenêtres à la française
à un et deux vantaux (à
fabriquer par le métallier)

UV = 10 pièces

Commander séparément:
557.162 Vis

557.079

Engagement block
black plastic, for single and
double-vent side-hung windows
(to made by metal constructor)

PU = 10 pieces

Order separately:
557.162 Screws



557.192

Kantenriegel
Aluminium, schwarz,
Verriegelungsstück aus Stahl,
Länge 140 mm, für Verriegelung
des Standflügels, inkl. 1 Büchse
aus Edelstahl und 3 Senk-
schrauben M4 selbstgewindend

VE = 1 Stück

Hinweis:
Bestehende Bohrungen für
M4 Schrauben aufbohren und
ansenken.

557.192

Verrou à bascule
aluminium, noir, pièce de
verrouillage en acier, longueur
140 mm, pour le verrouillage
du vantail semi-fixe, avec
douille en acier Inox et 3 vis à
tête fraisée M4 autotaraudeuse

UV = 1 pièce

Remarque:
Percer les trous existants
pour les vis M4 et chanfreiner.

557.192

Flush bolt
aluminium, black, keep made
from steel, length 140 mm,
for locking the secondary vent,
Including 1 stainless steel socket
and 3 M4 countersunk screw
self tapping

PU = 1 piece

Note:
Drill out and countersunk
existing holes for M4 screws.



557.139

Kantenriegel
Aluminium, schwarz,
Verriegelungsstück aus Stahl,
Länge 225 mm, für Verriegelung
des Standflügels, inkl. 1 Büchse
aus Edelstahl und 3 Senk-
schrauben M4 selbstgewindend

VE = 1 Stück

Hinweis:
Bestehende Bohrungen für
M4 Schrauben aufbohren und
ansenken.

557.139

Verrou à bascule
aluminium, noir, pièce de
verrouillage en acier, longueur
225 mm, pour le verrouillage
du vantail semi-fixe, avec
1 douille en acier Inox et 3 vis à
tête fraisée M4 autotaraudeus

UV = 1 pièce

Remarque:
Percer les trous existants
pour les vis M4 et chanfreiner.

557.139

Flush bolt
aluminium, black, keep made
from steel, length 225 mm,
for locking the secondary vent,
Including 1 stainless steel socket
and 3 M4 countersunk screw
self tapping

PU = 1 piece

Note:
Drill out and countersunk
existing holes for M4 screws.



557.172

Verriegelung oben (Variante)
Edelstahl, für zweiflügelige Fenster, Verriegelungsstück inkl. Schliessblech, Einbau im Falzbereich Gangflügel, in Kombination mit Verlängerung Fensterverriegelung 557.291. Variante, anstelle Kantenriegel im Standflügel oben.

VE = 1 Stück

557.172

Verrouillage en haut (variante)
acier inox, pour fenêtres à deux vantaux, pièce de verrouillage avec gâche, montage dans la zone de la feuillure, vantail de service, en combinaison avec une prolongation du verrouillage de fenêtre 557.291. Variante, au lieu du verrou à bascule en haut du vantail semi-fixe.

UV = 1 pièce

557.172

Top locking point (variant)
stainless steel, for double-vent windows, keep including strike plate, installation in rebate area of access vent, in combination with extension for window lock 557.291. Variant, instead of flush bolt in secondary vent at top.

PU = 1 piece



557.162

Schraube M4x7
Stahl verzinkt, Edelstahl-Look, Torx-Angriff

Bohrdurchmesser 3,5 mm

VE = 100 Stück

557.162

Vis M4x7
acier zingué, surface acier Inox, empreinte Torx

Diamètre de perçage 3,5 mm

UV = 100 pièces

557.162

Screw M4x7
galvanised steel, stainless steel surface, Torx head

Hole diameter 3,5 mm

PU = 100 pieces



557.164

Schraube M4x6
Edelstahl, Torx-Angriff

VE = 100 Stück

557.164

Vis M4x6
acier Inox, empreinte Torx

UV = 100 pièces

557.164

Screw M4x6
stainless steel, Torx head

PU = 100 pieces



557.266

Anschweissband links

Stahl, Länge 89 mm, ø 13 mm,
Dorn fest eingepresst,
Axialkugellager in Edelstahl

VE = 2 Stück

557.266

Paumelle à souder, gauche

acier, longueur 89 mm,
ø 13 mm, tige fixe sertie,
roulement à bille axial en
acier Inox

UV = 2 pièces

557.266

Weld-on hinge, left

steel, length 89 mm, ø 13 mm,
embedded pin, axial ball
bearing in stainless steel

PU = 2 pieces



557.267

Anschweissband rechts

Stahl, Länge 89 mm, ø 13 mm,
Dorn fest eingepresst,
Axialkugellager in Edelstahl

VE = 2 Stück

557.267

Paumelle à souder, droite

acier, longueur 89 mm,
ø 13 mm, tige fixe sertie,
roulement à bille axial en
acier Inox

UV = 2 pièces

557.267

Weld-on hinge, right

steel, length 89 mm, ø 13 mm,
embedded pin, axial ball
bearing in stainless steel

PU = 2 pieces



555.483

Anschweissband

Stahl blank, ø 10 mm,
Länge 57 mm, mit losem
Bolzen aus Edelstahl 1.4301
und Messing-Zwischenring

VE = 10 Stück

555.483

Paumelle à souder

acier brut, ø 10 mm, longueur
57 mm, avec tige amovible en
acier inoxydable 1.4301 et bague
intermédiaire en laiton

UV = 10 pièces

555.483

Weld-on hinge

steel raw, ø 10 mm, length
57 mm, with loose pin made
from stainless steel 1.4301 and
brass intermediate ring

PU = 10 pieces





550.209

Anschweissband

gezogener Stahl,
Länge 80 mm, \varnothing 13 mm,
Messing-Zwischenring,
Dorn fest eingepresst

VE = 25 Stück

550.209

Paumelle à souder

acier étiré,
longueur 80 mm, \varnothing 13 mm,
rondelle en laiton,
tige fixe sertie

UV = 25 pièces

550.209

Weld-on hinge

drawn steel, length 80 mm,
 \varnothing 13 mm, brass ring,
embedded pin

PU = 25 pieces

550.210

Anschweissband

gezogener Stahl,
Länge 100 mm, \varnothing 16 mm,
Messing-Zwischenring,
Dorn fest eingepresst

VE = 25 Stück

550.210

Paumelle à souder

en acier étiré,
longueur 100 mm, \varnothing 16 mm,
rondelle en laiton,
tige fixe sertie

UV = 25 pièces

550.210

Weld-on hinge

drawn steel, length 100 mm,
 \varnothing 16 mm, brass ring,
embedded pin

PU = 25 pieces



550.226

Anschweissband

gezogener Stahl,
Länge 80 mm, \varnothing 13 mm,
Messing-Zwischenring,
Dorn lose

VE = 25 Stück

550.226

Paumelle à souder

en acier étiré,
longueur 80 mm, \varnothing 13 mm,
rondelle en laiton,
tige mobile

UV = 25 pièces

550.226

Weld-on hinge

drawn steel, length 80 mm,
 \varnothing 13 mm, brass ring,
loose pin

PU = 25 pieces



557.265

Anschweissband

Stahl blank, \varnothing 16 mm,
Länge 190 mm, mit festem Dorn
und Messing-Zwischenring

VE = 2 Stück

557.265

Paumelle à souder

acier brut, \varnothing 16 mm, longueur
190 mm, avec tige fixe et
bague intermédiaire en laiton

UV = 2 pièces

557.265

Weld-on hinge

steel raw, \varnothing 16 mm, length
190 mm, with fixed spindle and
brass intermediate ring

PU = 2 pieces



550.414

Falzschere

Stahl, promatverzinkt,
bestehend aus Scherenarm,
Anschraubplatte und Schlitzplatte

VE = 1 Paar (links und rechts)
8 Linsensenkschrauben
M5x10 Inox

550.414

Compas d'arrêt pour fenêtre à soufflet

acier, promatisé, comprenant
bras de compas, support et
plaque mortaisés.

UV = 1 paire (gauche et droite)
8 vis à tête fraisée bombée
M5x10 acier Inox

550.414

Top light stay

steel, electrolytically galvanised,
comprising stay arm, screw-on
plate and slotted plate

PU = 1 pair (left and right)
8 oval head screws
M5x10 stainless steel



550.413

Oberlichtschnäpper

Aluminium, farblos eloxiert,
inkl. Flachkloben aus Stahl zum
Anschweissen 40x43 mm

VE = 1 Schnäpper
1 Flachkloben
2 Linsensenkschraube
M5x15 Inox

550.413

Loqueteau

aluminium, éloxé incolore,
incl. câble en acier à souder
40x43 mm

UV = 1 loqueteau
1 câble
2 vis à tête fraisée bombée
M5x15 acier Inox

550.413

Top light catch

aluminium, anodised colourless,
incl. flat plate in steel to weld-on
40x43 mm

PU = 1 catch
1 flat plate
2 oval head screws
M5x15 stainless steel

Zusatz-Beschläge für Fenstertüren mit Schloss und Drücker

Hinweis*

Diese Konzeption ist lediglich für sogenannte Fenstertüren vorgesehen. Es handelt sich um eine Sonderkonstruktion und ist eine Kombination aus den Systemserien Art'System (Fenster) und Jansen-Economy 50 (Türen).

Ferrures complémentaire pour portes-fenêtres avec serrure et poignée

Indication*

Cette conception est réservée à des portes-fenêtres. Il s'agit d'une combinaison entre les gammes Art'System (fenêtres) et Jansen-Economy 50 (portes). L'utilisation de ceux-ci sera réservée pour l'usage domestique, non intensif.

Additional fittings for window doors with lock and handle

Note*

This design is only provided for so-called window doors. It is a special construction and is a combination of the Art system (windows) and Jansen-Economy 50 (doors) system series.

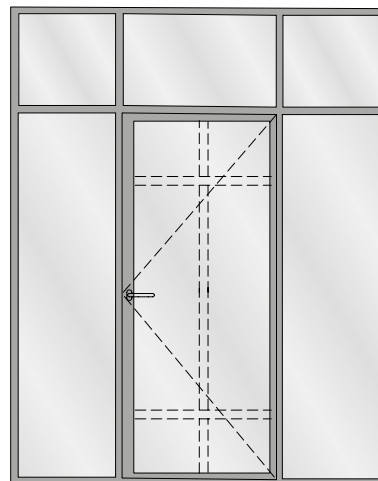
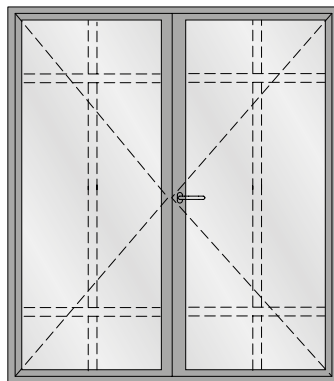
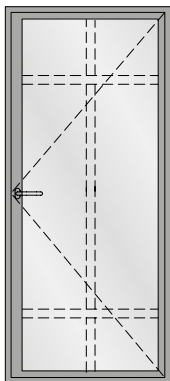

* Sonderkonstruktion
(nach Produktnorm EN 14351
nicht geprüft)

* Construction spéciale
(non contrôlé selon la norme
produit EN 14351)

* Special construction
(not tested in accordance with
the EN 14351 product standard)



550.191 ø 17 mm

Fallenriegel-Schloss

mit Wechsel, Riegelausschluss
1-tourig 20 mm, Kasten verzinkt,
Falle und Riegel vernickelt,
Stulp Edelstahl

VE = 1 Fallenriegel-Schloss

Zusätzlich bestellen:

555.490 Schrauben
555.720 Schliessblech

550.191 ø 17 mm

Serrure à mortaiser

avec levier, course du pêne à
1 tour 20 mm, boîtier zingué,
bec de cane et pêne nickelés,
tête en acier Inox

UV = 1 serrure à mortaiser

Commander séparément:

555.490 Vis
555.720 Gâche de fermeture

550.191 ø 17 mm

Latch and bolt lock

with latch retention, travel
of bolt 1 turn 20 mm, case
galvanised, latch and bolt
nickel-plated, face plate
stainless steel

PU = 1 latch and bolt lock

Order separately:

555.490 Screws
555.720 Strike plate



550.193 ø 17 mm

Rollfallen-Schloss

Riegelausschluss 1-tourig
20 mm, Kasten verzinkt,
verstellbare Rollfalle, Riegel
vernickelt, Stulp Edelstahl

VE = 1 Rollfallen-Schloss

Zusätzlich bestellen:

555.490 Schrauben
555.721 Schliessblech

550.193 ø 17 mm

Serrure à mortaiser à rouleau

course du pêne à 1 tour 20 mm,
boîtier zingué, rouleau réglable,
pêne nickelés, tête en
acier Inox

UV = 1 serrure à mortaiser à
rouleau

Commander séparément:

555.490 Vis
555.721 Gâche de fermeture

550.193 ø 17 mm

Roller latch lock

travel of bolt 1 turn 20 mm,
case galvanised, adjustable
roller latch, bolt nickel-plated,
face plate stainless steel

PU = 1 roller latch lock

Order separately:

555.490 Screws
555.721 Strike plate



559.210 ø 17 mm

Fallenriegel-Schloss

für Profile mit Körperbreite
25 mm, mit Wechsel, Dornmass
18 mm, **Nuss 8x8 mm**,
Stulp Edelstahl, Schlosskasten
verzinkt, links und rechts
umstellbar, Riegelausschluss
1-tourig 11 mm

VE = 1 Fallenriegel-Schloss

Zusätzlich bestellen:

550.268 Schrauben
559.217 Schliessblech

559.210 ø 17 mm

Serrure à mortaiser

pour profilés avec largeur
25 mm, avec levier, axe canon/
tête 18 mm, **fouillot 8x8 mm**,
tête en acier Inox, boîtier
zingué, utilisable à droite et
à gauche, course du pêne à
1 tour 11 mm

UV = 1 serrure à mortaiser

Commander séparément:

550.268 Vis
559.217 Gâche de fermeture

559.210 ø 17 mm

Latch and bolt lock

for profiles with face width
25 mm, with latch retention,
backset 18 mm, **8x8 mm boss**,
stainless steel face plate,
galvanised casing, can be used
left and right, travel of bolt
1 turn 11 mm

PU = 1 latch and bolt lock

Order separately:

550.268 Screws
559.217 Strike plate



555.720

Schliessblech
Edelstahl, für Fallenriegel-
Schlösser 550.191,
links und rechts einsetzbar

VE = 1 Schliesblech

Zusätzlich bestellen:
555.490 Schrauben

555.720

Gâche de fermeture
acier Inox, pour serrures à
mortaiser 550.191,
utilisable à gauche et à droite

UV = 1 gâche de fermeture

Commander séparément:
555.490 Vis

555.720

Strike plate
stainless steel, for latch and
bolt locks 550.191,
can be used LH and RH

PU = 1 strike plate

Order separately:
555.490 Screws



555.721

Schliessblech
Edelstahl, für Rollfallen-
Schlösser 550.193,
links und rechts einsetzbar

VE = 1 Schliesblech

Zusätzlich bestellen:
555.490 Schrauben

555.721

Gâche de fermeture
acier Inox, pour serrures à
mortaiser à rouleau 550.193,
utilisable à gauche et à droite

UV = 1 gâche de fermeture

Commander séparément:
555.490 Vis

555.721

Strike plate
stainless steel, for roller
latch locks 550.193,
can be used LH and RH

PU = 1 strike plate

Order separately:
555.490 Screws



559.217

Schliessblech
Edelstahl, zu Schloss 559.210,
links und rechts einsetzbar

VE = 1 Schliesblech

Zusätzlich bestellen:
555.490 Schrauben

559.217

Gâche de fermeture
acier Inox, pour serrure 559.210,
utilisable à gauche et à droite

UV = 1 gâche de fermeture

Commander séparément:
555.490 Vis

559.217

Strike plate
stainless steel, for lock 559.210,
can be used LH and RH

PU = 1 strike plate

Order separately:
555.490 Screws



555.466

Kantenbascule

Stulp Edelstahl, Hub 14 mm, Anschlussgewinde M5, Verwendung zusammen mit Treibriegelstangen M5 (555.418/419)

VE = 1 Kantenbascule

Einbau mit
499.149 \varnothing 22 mm
499.150 \varnothing 17 mm

Bei Bedarf zusätzlich bestellen:
555.490 Schrauben
555.595 Standflügelverriegelung
555.418/ Treibriegelstange
555.419

555.466

Verrou à entailler à bascule

têtière en acier Inox, course 14 mm, raccord taraudé M5, à utiliser avec tiges de verrouillage M5 (555.418/419)

UV = 1 verrou à entailler à bascule

Montage avec
499.149 \varnothing 22 mm
499.150 \varnothing 17 mm

Commander en plus si besoin:
555.490 Vis
555.595 Verrouillage pour vantail semi-fixe
555.418/ Tige de verrouillage
555.419

555.466

Espagnolette

face plate stainless steel, travel 14 mm, connecting thread M5, use in conjunction with shoot bolts M5 (555.418/419)

PU = 1 espagnolette

Installation with
499.149 \varnothing 22 mm
499.150 \varnothing 17 mm

Order separately if required:
555.490 Screws
555.595 Additional set for secondary leaf
555.418/ Shoot bolt
555.419



555.418 1,5 m

Treibriegelstange oben

Stahl verzinkt, \varnothing 10 x 1,5 mm, mit Gewindeteil M5, mit Kunststoff-Endstopfen, für Kantenbascule 555.466

VE = 1 Stück

555.418 1,5 m

Tige de verrouillage supérieure

acier zingué, \varnothing 10 x 1,5 mm, avec filetage M5, avec embout en plastique, pour verrou à entailler à bascule 555.466

UV = 1 pièce

555.418 1,5 m

Shoot bolt (top)

galvanised steel, \varnothing 10 x 1,5 mm, with M5 thread, with plastic end stopper, for espagnolette 555.466

PU = 1 piece



555.419 1,42 m

Treibriegelstange unten

Stahl verzinkt, \varnothing 10 mm, mit Gewindeteil M5, ohne Endstopfen, für Kantenbascule 555.466

VE = 1 Stück

555.419 1,42 m

Tige de verrouillage inférieure

acier zingué, \varnothing 10 mm, avec filetage M5, sans embout, pour verrou à entailler à bascule 555.466

UV = 1 pièce

555.419 1,42 m

Shoot bolt (bottom)

galvanised steel, \varnothing 10 mm, with M5 thread, without end stopper, for espagnolette 555.466

PU = 1 piece



555.910

Mehrfachverriegelungs-Schloss
mit Wechsel, Dornmass 30 mm,
Nuss 8x8 mm, Edelstahl U-Stulp
24x6x2 mm, Länge 2300 mm,
Schlosskasten pulverbeschichtet,
Hauptschloss mit Falle und
Riegel, links und rechts
umstellbar, Riegelausschluss
2-tourig 22 mm

VE = 1 Stück

Bei Bedarf zusätzlich bestellen:

- 555.911 Schliessblech
Hauptschloss
- 555.912 Schliessblech
Nebenschlösser
- 555.490 Schrauben

555.910

Serrure à verrouillage multiple
avec levier, canon/têteière 30 mm,
fouillot 8x8 mm, têteière en U en
acier inox 24x6x2 mm, longueur
2300 mm, boîtier thermolaqué
par poudre, serrure principale
avec bec-de-cane et pêne, utili-
sable à droite et à gauche, cour-
se du pêne à 2 tours 22 mm

UV = 1 pièce

Commander en plus si besoin:

- 555.911 Gâche de fermeture
serrure principale
- 555.912 Gâche de fermeture
serrures secondaires
- 555.490 Vis

555.910

Multi-point lock
With latch retention, 30 mm
backset, 8 x 8 mm groove,
24 x 6 x 2 mm stainless steel
U-shaped face plate, length
2300 mm, powder-coated lock
case, main lock with latch and
bolt, adjustable on the left and
right, double-turn, 22 mm bolt
extension

PU = 1 piece

Order separately if required:

- 555.911 Strike plate
main lock
- 555.912 Strike plat
auxiliary locks
- 555.490 Screws

555.911

Schliessblech
Edelstahl, 180x24x3 mm,
für Hauptschloss 555.910

VE = 1 Stück

555.911

Gâche de fermeture
acier Inox, 180x24x3 mm,
pour serrure principale 555.910

UV = 1 pièce

555.911

Strike plate
stainless steel, 180x24x3 mm,
for main lock 555.910

PU = 1 piece

555.912

Schliessblech
Edelstahl, 132x24x3 mm,
für Nebenschlösser 555.910

VE = 2 Stück

555.912

Gâche de fermeture
acier Inox, 132x24x3 mm, pour
serrures secondaires 555.910

UV = 2 pièces

555.912

Strike plate
stainless steel, 132x24x3 mm,
for auxiliary locks 555.910

PU = 2 pieces



559.212 F1 eloxiert
559.224 F9 titan eloxiert

Drücker
Aluminium, Ausladung 24 mm,
fest drehbar gelagert, Lochteil
8x8 mm, passend zu Schlösser
mit Vierkantnuss 8 mm

VE = 1 Stück

Zusätzlich bestellen:
550.267 Schrauben
559.213 Vierkant-Dorn

559.212 F1 anodisé
559.224 F9 anodisé titan

Poignée
aluminium, surplomb 24 mm,
montée rivée tournante,
perforation 8x8 mm, convient
au serrures avec fouillot 8 mm

UV = 1 pièce

Commander séparément:
550.267 Vis
559.213 Tige carrée

559.212 F1 anodised
559.224 F9 titan anodised

Handle
aluminium, projection 24 mm,
fixed rotatable mount, 8x8 mm
hole plate, suitable for locks
with 8 mm boss

PU = 1 piece

Order separately:
550.267 Screws
559.213 Square spindle



559.213
Vierkant-Dorn 8 mm
Stahl gehärtet, verzinkt,
Länge 100 mm

VE = 5 Stück

559.213
Tige carrée 8 mm
acier trempé, zingué,
longueur 100 mm

UV = 5 pièces

559.213
Square spindle 8 mm
steel reinforced, galvanised,
length 100 mm

PU = 5 pieces



555.857
Flachdrücker
Edelstahl, Ausladung
23 mm, fest drehbar gelagert,
für Drückerstift 9 mm

VE = 1 Stück

555.857
Poignée plate
acier Inox, surplomb 23 mm,
rivée tournante, pour tige
carrée de 9 mm

UV = 1 pièce

555.857
Flat handle
stainless steel, 23 mm
projection, screw-fixed,
for 9 mm handle spindle

PU = 1 piece



555.586

Edelstahl-Drücker-Lochteil
matt, mit Gleitlager, mit Clips-
Ovalrosette 70x33x13 mm
festdrehbar gelagert, mit
Hochhaltefeder, für
Drückerstift 9 mm

Breite: 175 mm
Tiefe: 85 mm

VE = 1 Stück

Zusätzlich bestellen:

555.297 Blindnietmutter M5
555.515 Schrauben
555.591 Drückerstift



555.586

Poignée femelle en acier Inox
mat, avec palier lisse, avec rosace
ovale à clips 70x33x13 mm rivée
tournante, avec ressort de rappel,
pour tige carrée 9 mm

Largeur: 175 mm
Profondeur: 85 mm

UV = 1 pièce

Commander séparément:

555.297 Ecrou aveugle M5
555.515 Vis
555.591 Tige carrée

555.586

**Stainless steel handle
without spindle**
matt, with friction bearing, with
oval clip-on rosette 70x33x13 mm,
with return spring, for handle
spindle 9 mm

Width: 175 mm
Depth: 85 mm

PU = 1 piece

Order separately:

555.297 Blind rivet M5
555.515 Screws
555.591 Handle spindle



555.588

Edelstahl-Drücker-Lochteil
matt, mit Gleitlager, mit Clips-
Ovalrosette 70x33x13 mm
festdrehbar gelagert, mit
Hochhaltefeder, für
Drückerstift 9 mm

Breite: 170 mm
Tiefe: 72 mm

VE = 1 Stück

Zusätzlich bestellen:

555.297 Blindnietmutter M5
555.515 Schrauben
555.591 Drückerstift



555.588

Poignée femelle en acier Inox
mat, avec palier lisse, avec rosace
ovale à clips 70x33x13 mm
rivée tournante, avec ressort de
rappel, pour tige carrée
9 mm

Largeur: 170 mm
Profondeur: 72 mm

UV = 1 pièce

Commander séparément:

555.297 Ecrou aveugle M5
555.515 Vis
555.591 Tige carrée

555.588

**Stainless steel handle
without spindle**
matt, with friction bearing, with
oval clip-on rosette 70x33x13 mm,
fixed swivel mounted, for handle
spindle 9 mm

Width: 170 mm
Depth: 72 mm

PU = 1 piece

Order separately:

555.297 Blind rivet M5
555.515 Screws
555.591 Handle spindle



555.591

Drückerstift
Vierkant 9 mm, Stahl gehärtet,
verzinkt, Länge 100 mm

VE = 1 Stück

555.591

Tige carré
carré 9 mm, acier trempé,
zingué, longueur 100 mm

UV = 1 pièce

555.591

Handle spindle
square 9 mm, steel reinforced,
galvanised, Length 100 mm

PU = 1 piece

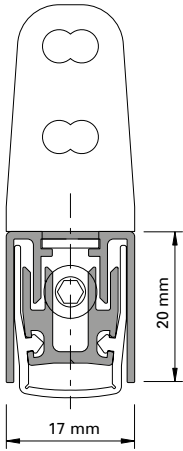

Automatische Senkdichtung

Aluminium, Dichtung aus Silikon, seitliche Befestigung mit Winkeln aus Edelstahl, links und rechts einsetzbar. Die Dichtungen lösen bandseitig aus und der Hub ist einstellbar bis 16 mm. Parallelabsenkung mit automatischem Ausgleich bei schiefem Boden. Einseitig kürzbar bis zur nächst kleineren Nennlänge.

VE = 1 Stück
 2 Befestigungswinkel

Joint seuil automatique

aluminium, joint en silicon, fixation latérale par équerres en acier Inox, utilisable à gauche et à droite. Les joints se déclenchent côté paumelle et la course est réglable jusqu'à 16 mm. Abaissement parallèle avec compensation automatique sur sol en pente. Peut être raccourci d'un côté jusqu'à la longueur nominale inférieure la plus proche.

UV = 1 pièce
 2 équerres de fixation

Automatic drop seal

aluminium, weatherstrip made of silicone, lateral fastening with stainless steel brackets, can be used LH and RH. The weatherstrips are removed on the hinge side and the travel can be set at up to 16 mm. Parallel settlements with automatic compensation on sloping ground. Can be shortened on one side as far as the next smallest nominal length.

PU = 1 joint
 2 angled brackets

Art.-Nr.	max. FFB mm	min. FFB mm
555.366	400	275
555.367	550	400
555.368	700	550
555.369	850	700
555.370	1000	850

No d'art	max. FFB mm	min. FFB mm
555.366	400	275
555.367	550	400
555.368	700	550
555.369	850	700
555.370	1000	850

Part no.	max. FFB mm	min. FFB mm
555.366	400	275
555.367	550	400
555.368	700	550
555.369	850	700
555.370	1000	850

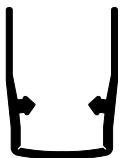

456.116

Dichtungsprofil

Silikon, Ersatzdichtung für automatische Senkdichtung 555.366 - 555.370

VE = 1,5 m

456.116

Profilé d'étanchéité

silicone, joint de remplacement pour joint seuil automatique 555.366 - 555.370

UV = 1,5 m

456.116

Gasket profile

silicone, spare gasket for automatic drop seal 555.366 - 555.370

PU = 1,5 m



555.490

Senkschraube M5x12

Stahl verzinkt, Edelstahl-Look, SR1-Angriff, selbstgewindend, 100° Senkkopf, für die Befestigung der Schlösser mit Edelstahl-Stulp und Zubehör aus Edelstahl

Bohrdurchmesser \varnothing 4,5 mm

VE = 500 Stück

555.490

Vis à tête fraisée M5x12

acier zingué, surface acier Inox, empreinte SR1, autotaraudeuse, tête noyée 100°, pour la fixation des serrures avec têtière en acier Inox et accessoires en acier Inox

Diamètre de perçage \varnothing 4,5 mm

UV = 500 pièces

555.490

Countersunk screw M5x12

galvanised steel, stainless steel surface, SR1 head, self-tapping, 100° countersunk, for fixing locks with stainless steel face plate and lock accessories

Hole diameter \varnothing 4.5 mm

PU = 500 pieces



550.322

Senkschraube M5x12

Edelstahl, SR1-Angriff, selbstgewindend, 100° Senkkopf, für die Befestigung der Schlösser mit Edelstahl-Stulp und Schloss-Zubehörteile aus Edelstahl

Bohrdurchmesser \varnothing 4,5 mm

VE = 500 Stück

550.322

Vis à tête fraisée M5x12

acier Inox, empreinte SR1, autotaraudeuse, tête noyée 100°, pour la fixation des serrures avec têtière en acier Inox et accessoires en acier Inox

Diamètre de perçage \varnothing 4,5 mm

UV = 500 pièces

550.322

Countersunk screw M5x12

stainless steel, SR1 head, self-tapping, 100° countersunk, for fixing locks with stainless steel face plate and lock accessories.

Hole diameter \varnothing 4.5 mm

PU = 500 pieces



555.486

Schraube M4x7

Stahl, Edelstahl-Look, SR1-Angriff, selbstgewindend

Bohrdurchmesser 3,6 mm

VE = 100 Stück

555.486

Vis M4x7

acier, surface acier Inox, empreinte SR1, autotaraudeuse

Diamètre de perçage 3,6 mm

UV = 100 pièces

555.486

Screw M4x7

steel, stainless steel surface, SR1 head, self-tapping

Hole diameter 3.6 mm

PU = 100 pieces



555.515

Senkschraube M5x16

Stahl verzinkt, SR1-Angriff, selbstgewindend, 100° Senkkopf, für die Befestigung der Drücker, Panik-Stangenriffe und Rosetten

Bohrdurchmesser \varnothing 4,5 mm

VE = 100 Stück

555.515

Vis à tête fraisée M5x16

acier zingué, empreinte SR1, autotaraudeuse, tête noyée 100°, pour la fixation des poignées, barre panique et rosaces

Diamètre de perçage \varnothing 4,5 mm

UV = 100 pièces

555.515

Countersunk screw M5x16

galvanised steel, SR1 head, self-tapping, 100° countersunk, for fixing handles, locking bars with emergency function and rosettes

Hole diameter \varnothing 4,5 mm

PU = 100 pieces

Fenster

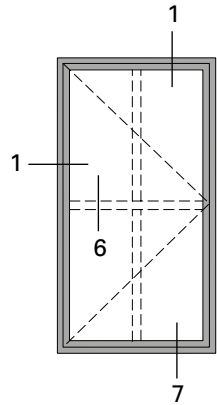

Fenêtres

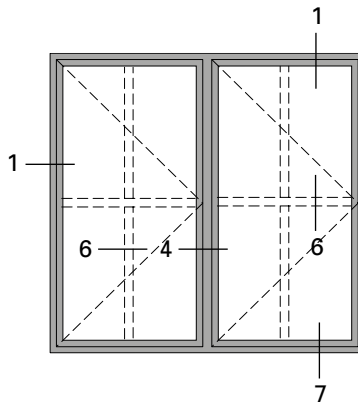

Windows

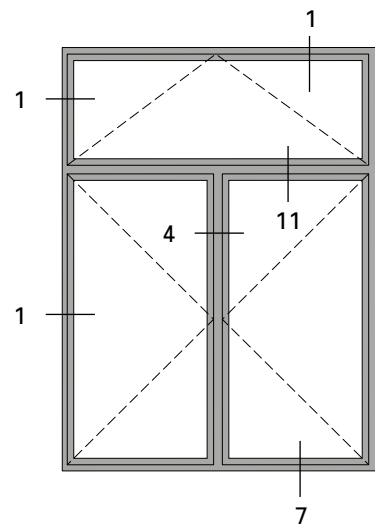
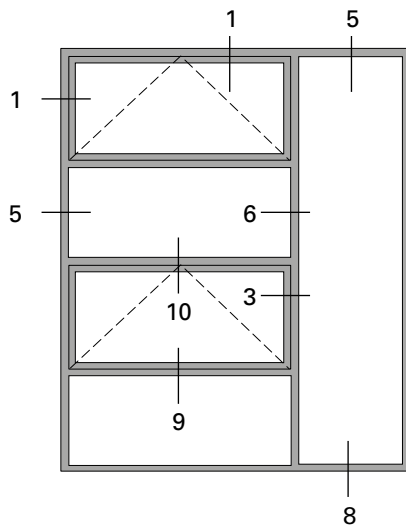
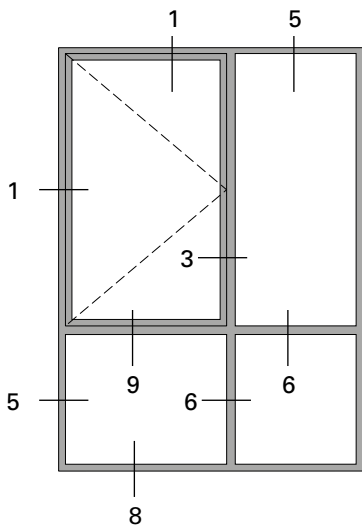
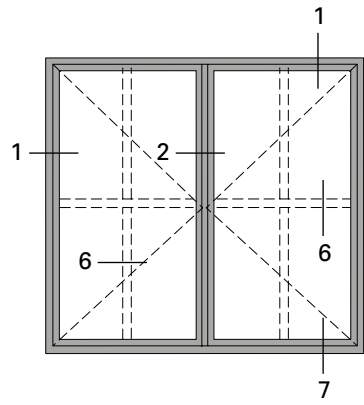

Fenstertüren
 mit Fensterbeschlag

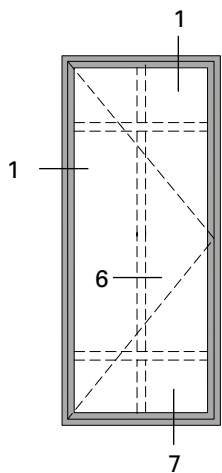

Portes-fenêtres
 avec ferrure de fenêtre

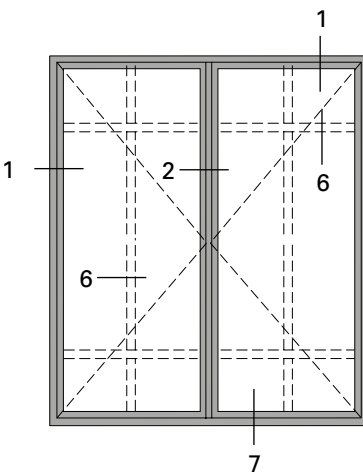

Windows-doors
 with window fitting

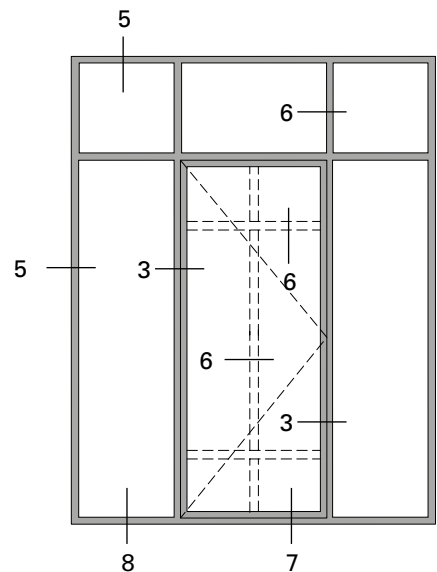

1.0

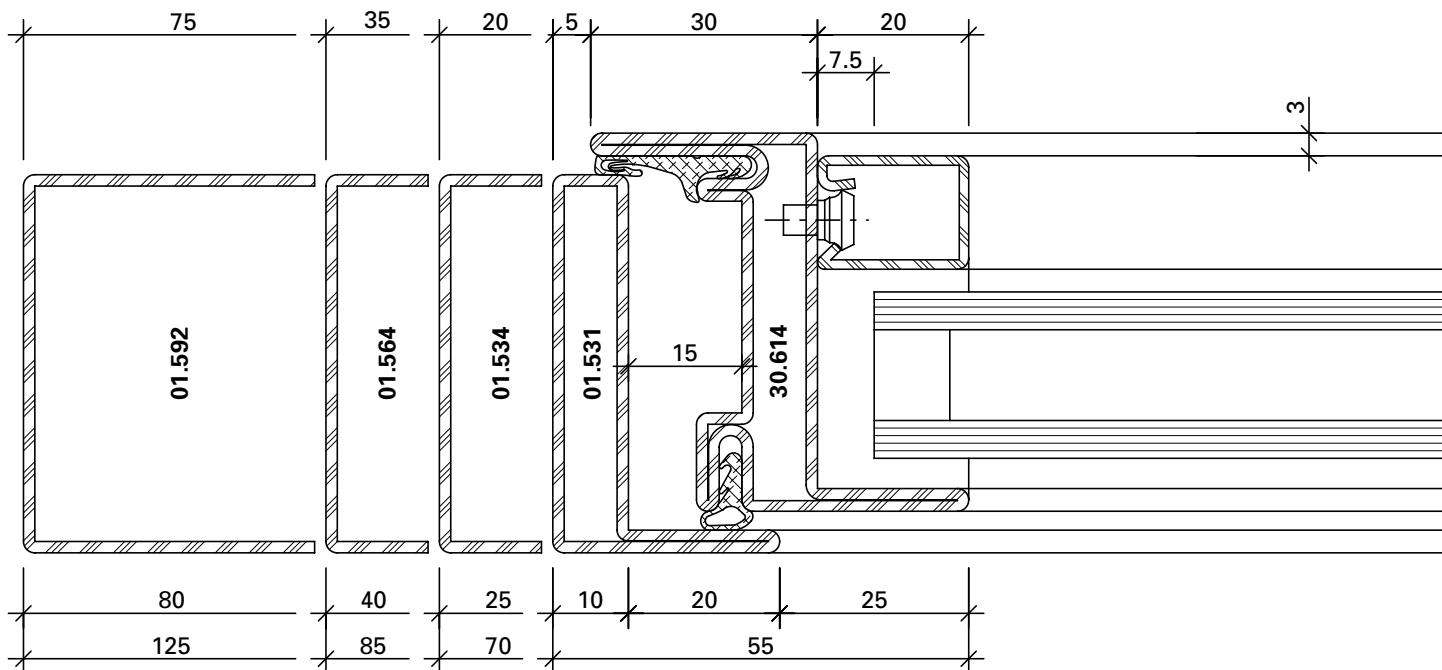

DXF **DWG** 23-0101-C-001

2.0

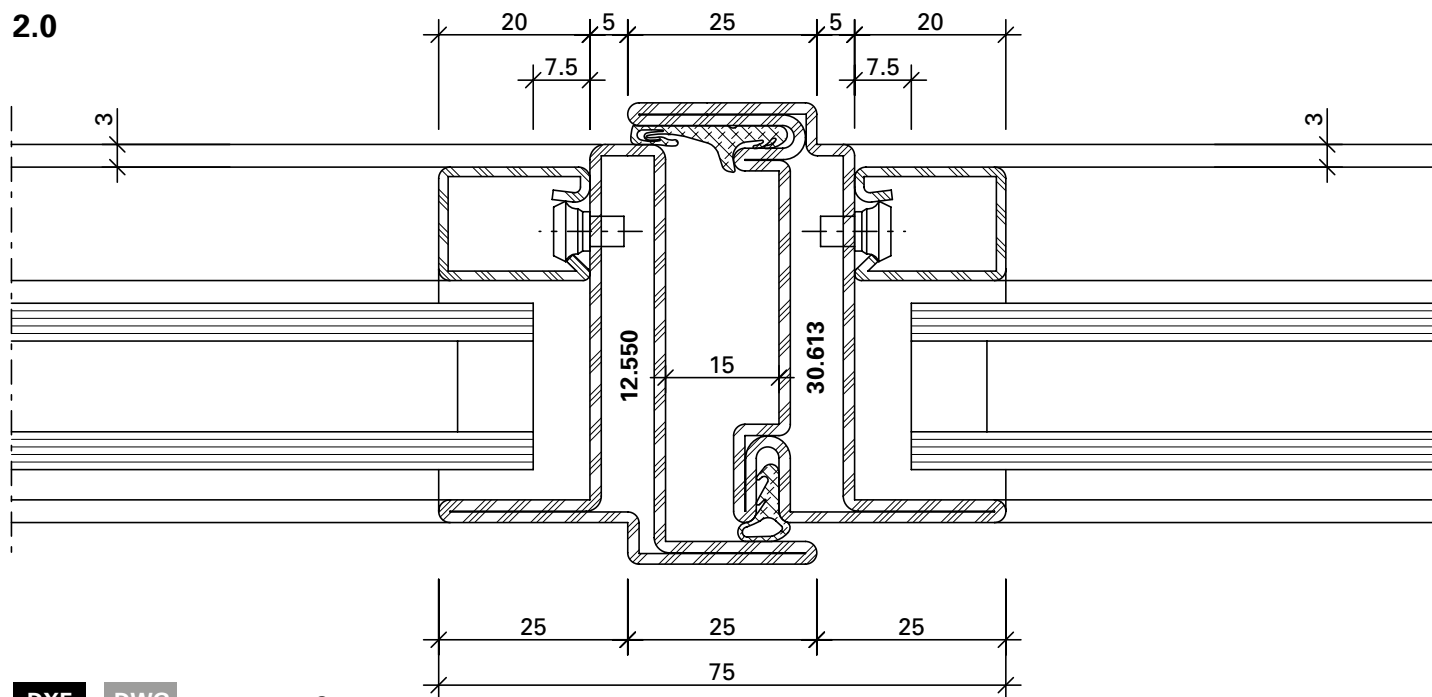

DXF **DWG** 23-0101-C-002

1.1

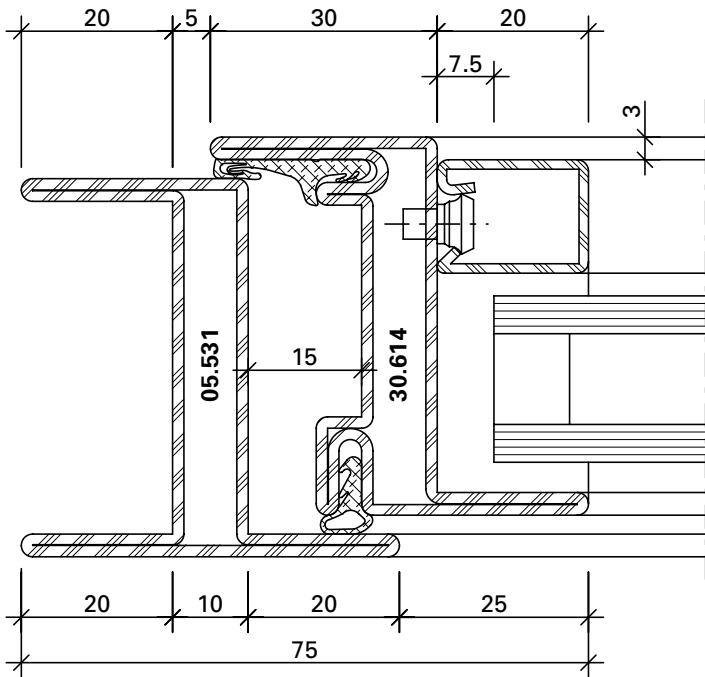

DXF **DWG** 23-0101-C-003

1.2

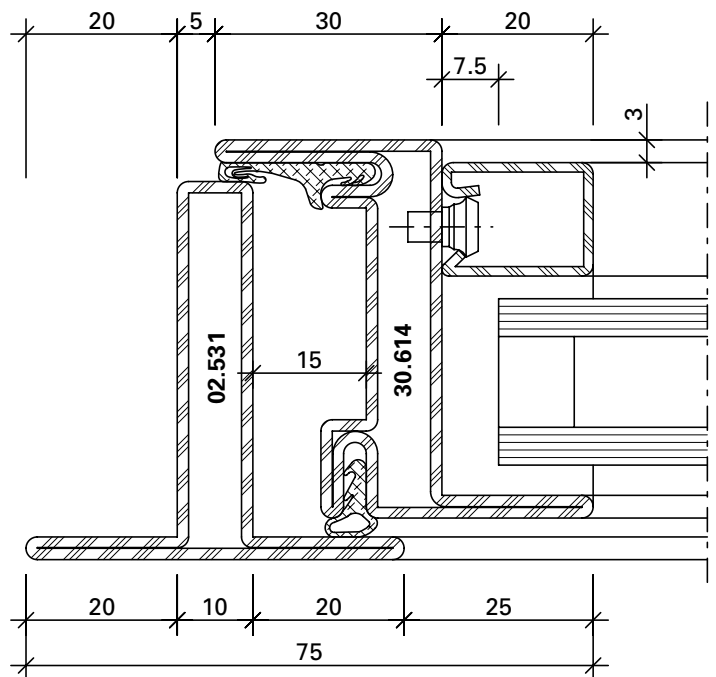

DXF **DWG** 23-0101-C-004

1.4

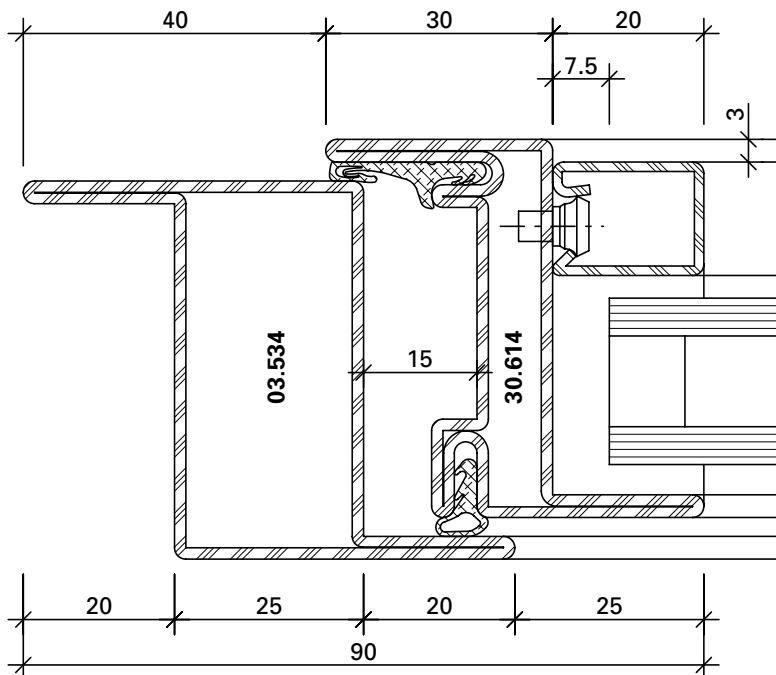

DXF **DWG** 23-0101-C-005

1.3

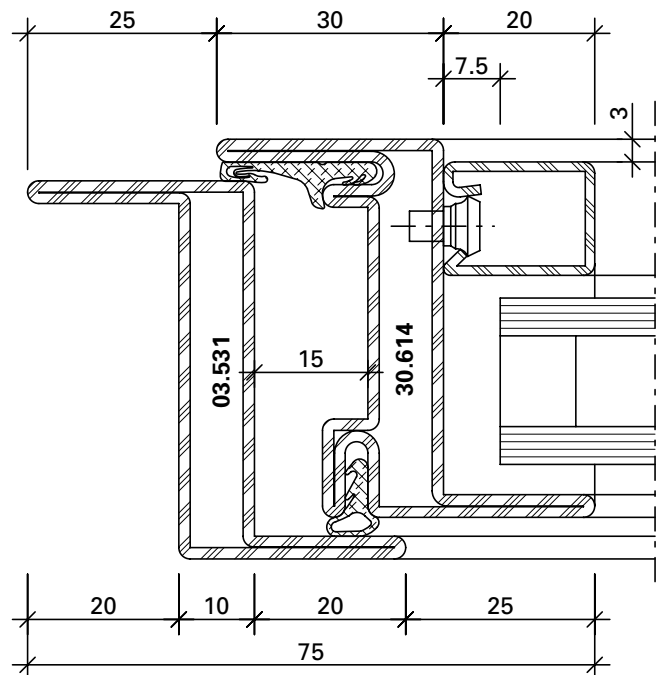

DXF **DWG** 23-0101-C-006

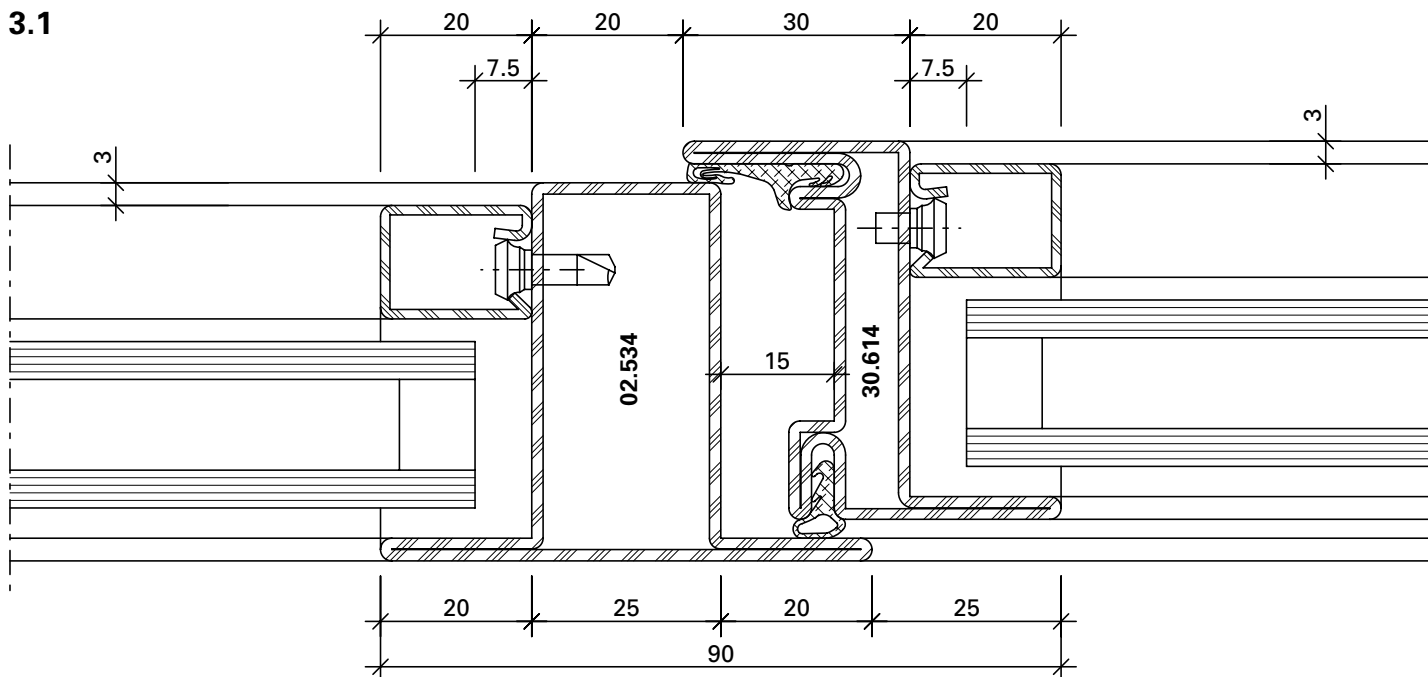

DXF **DWG** 23-0101-C-007

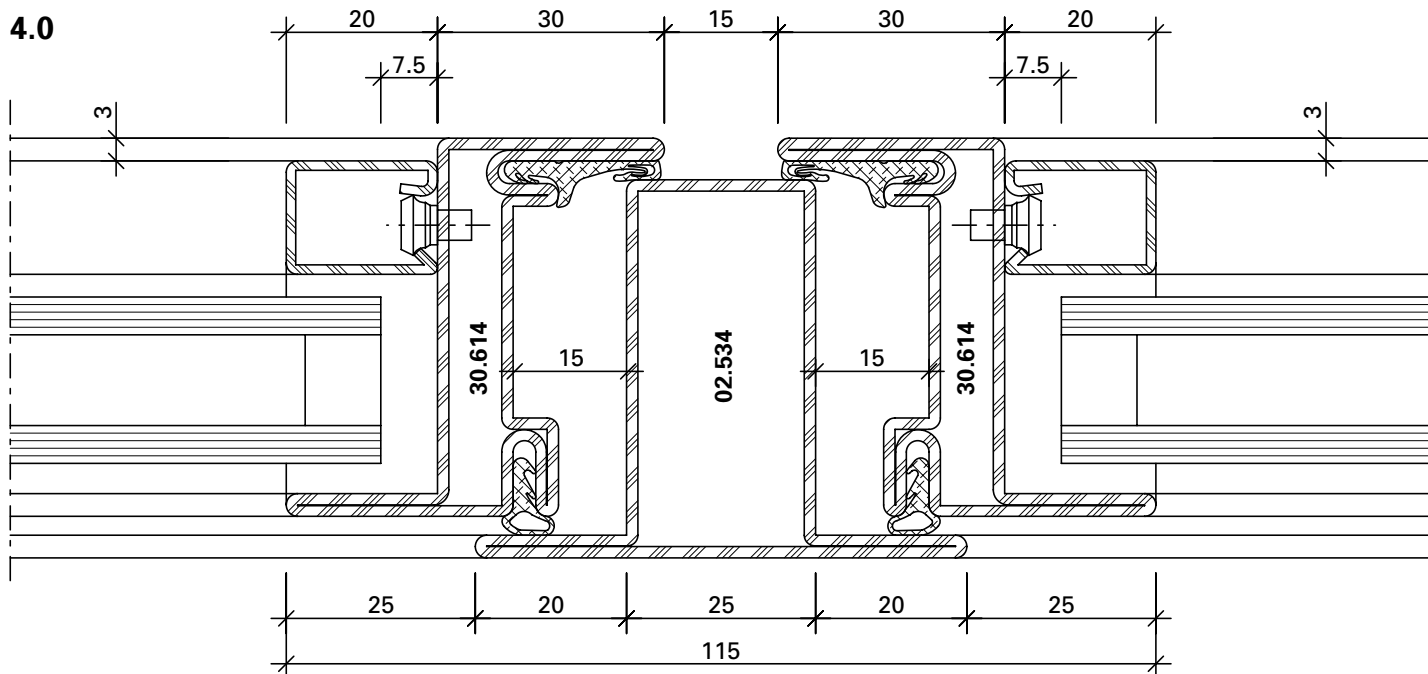

DXF **DWG** 23-0101-C-008

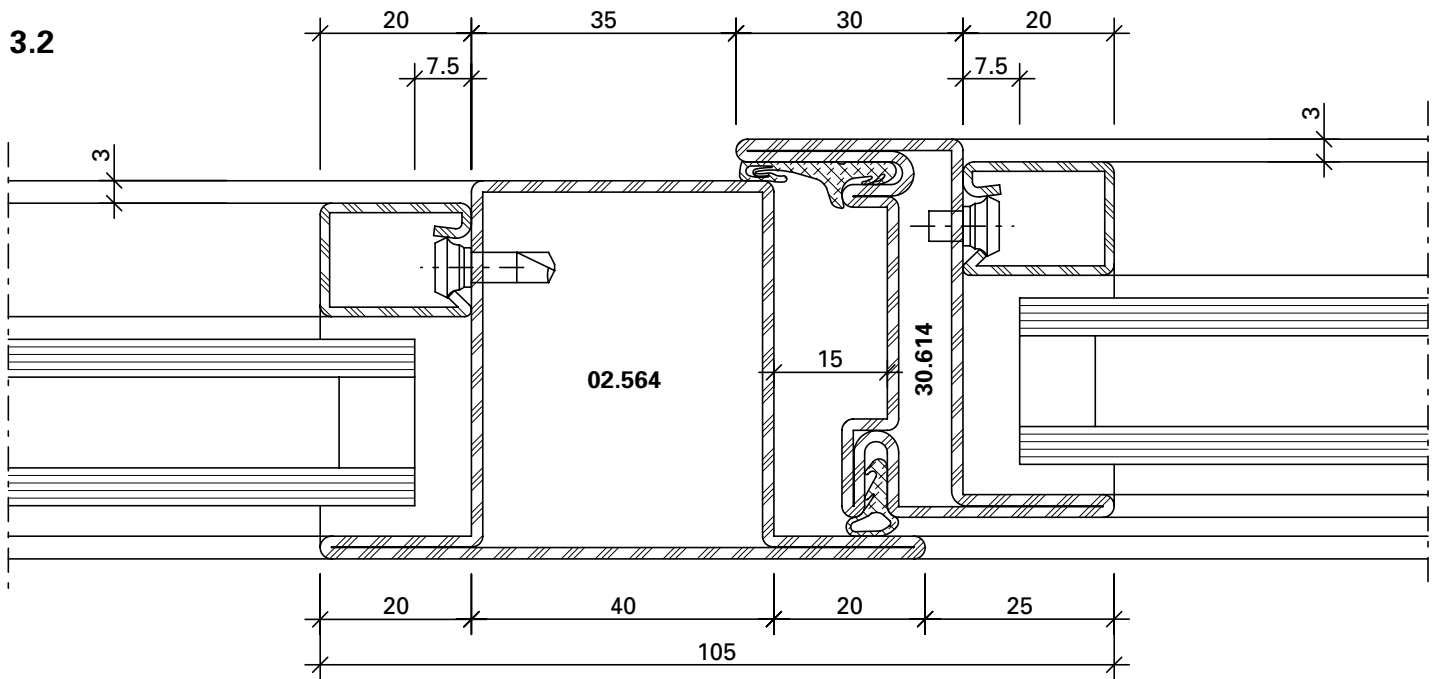

DXF **DWG** 23-0101-C-009

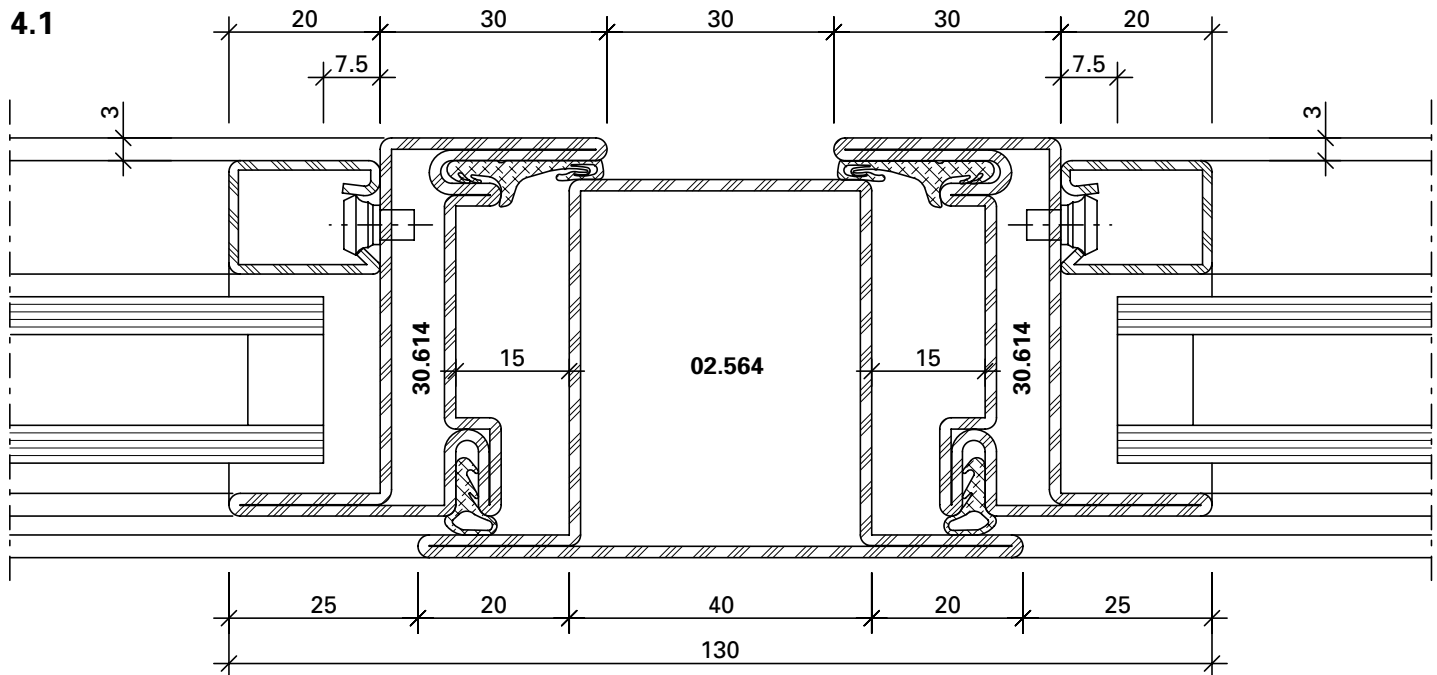

DXF **DWG** 23-0101-C-010

3.0

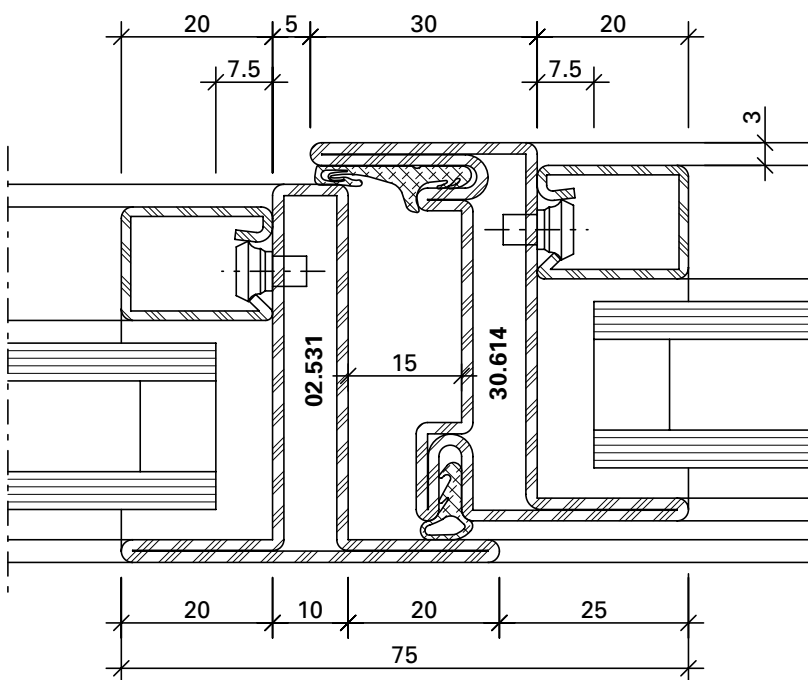

DXF **DWG** 23-0101-C-011

5.1

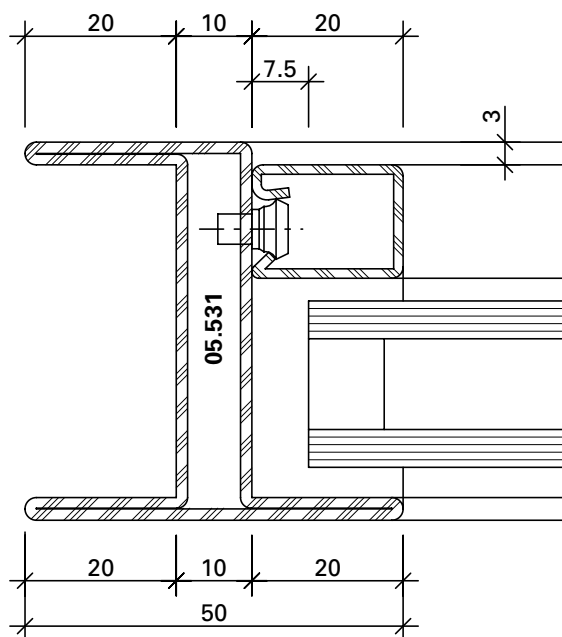

DXF **DWG** 23-0101-C-012

5.0

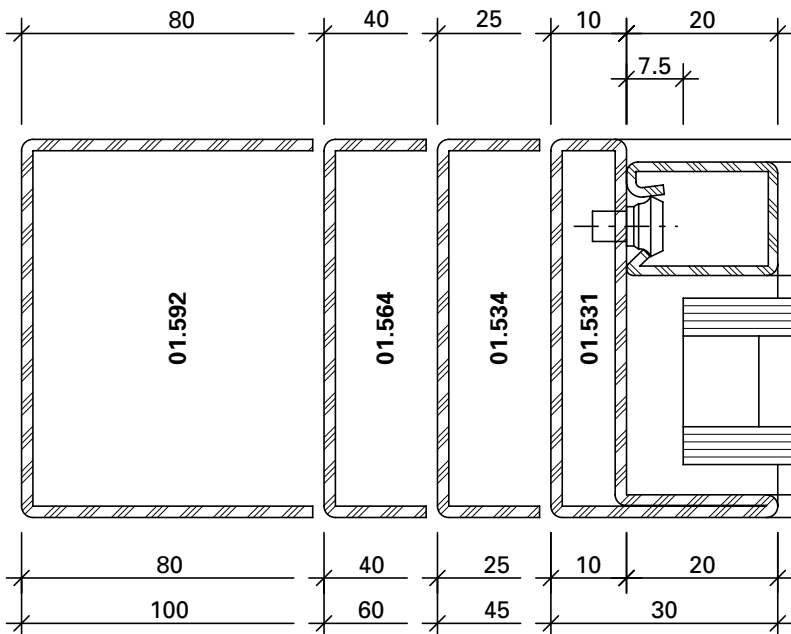

DXF **DWG** 23-0101-C-013

6.2

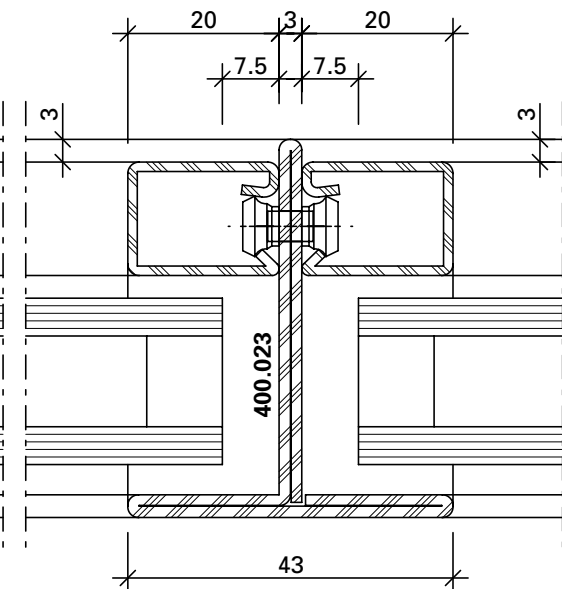

DXF **DWG** 23-0101-C-014

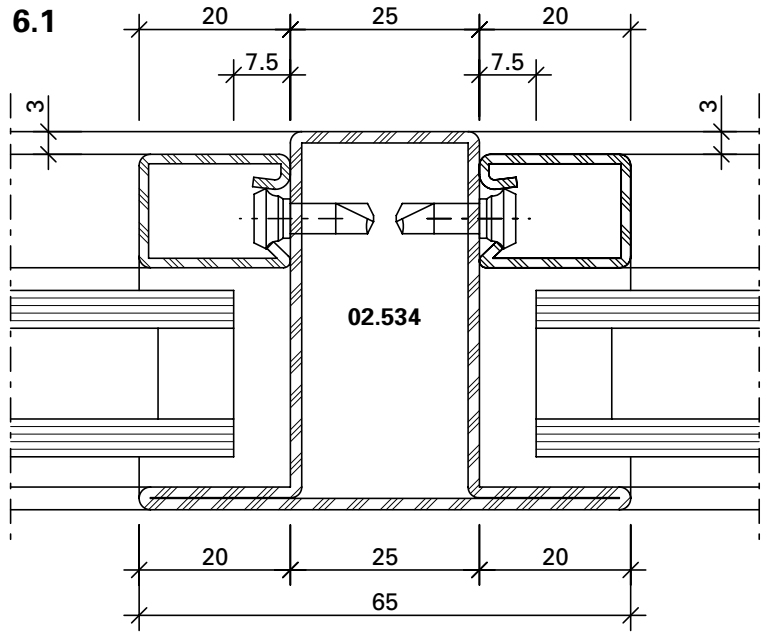
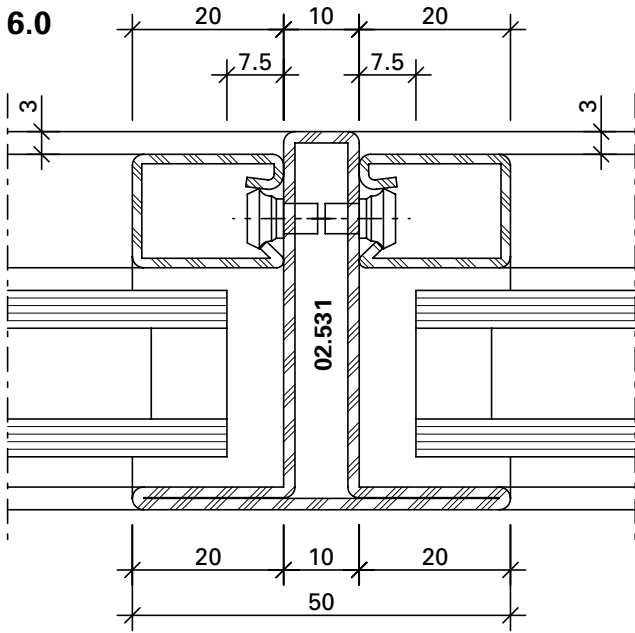

DXF **DWG** 23-0101-C-015

DXF **DWG** 23-0101-C-016

5.2

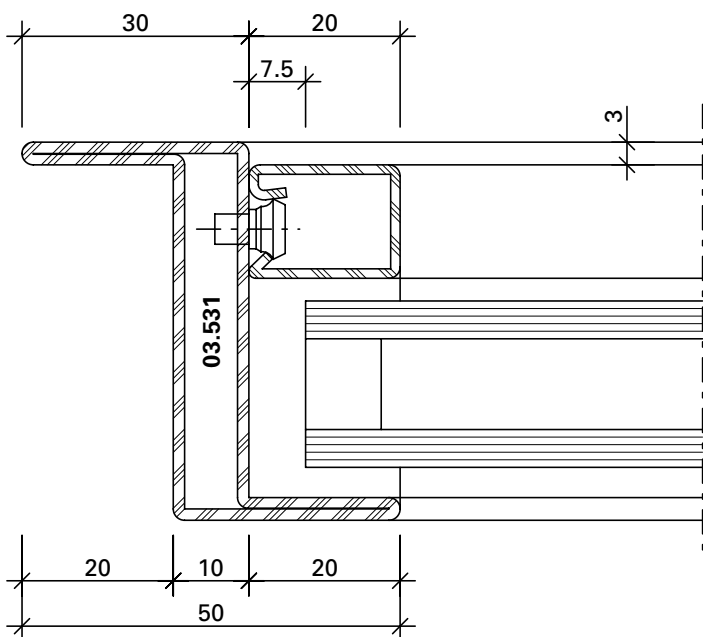

DXF **DWG** 23-0101-C-018

5.4

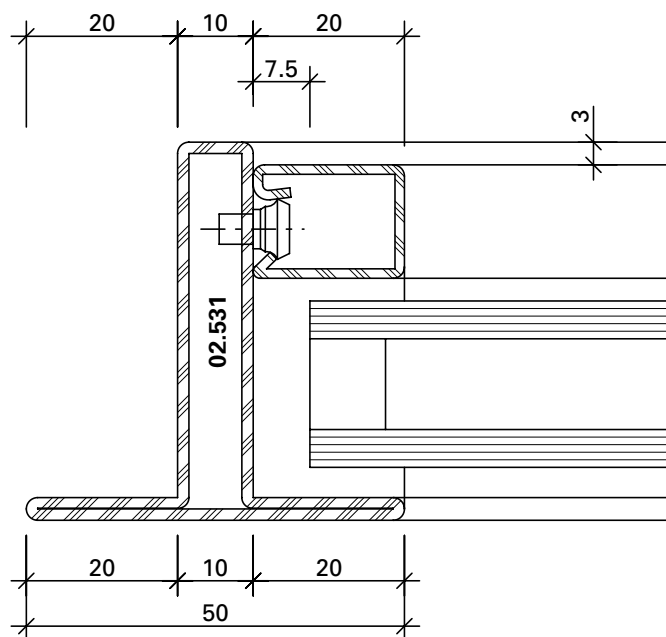

DXF **DWG** 23-0101-C-019

5.4

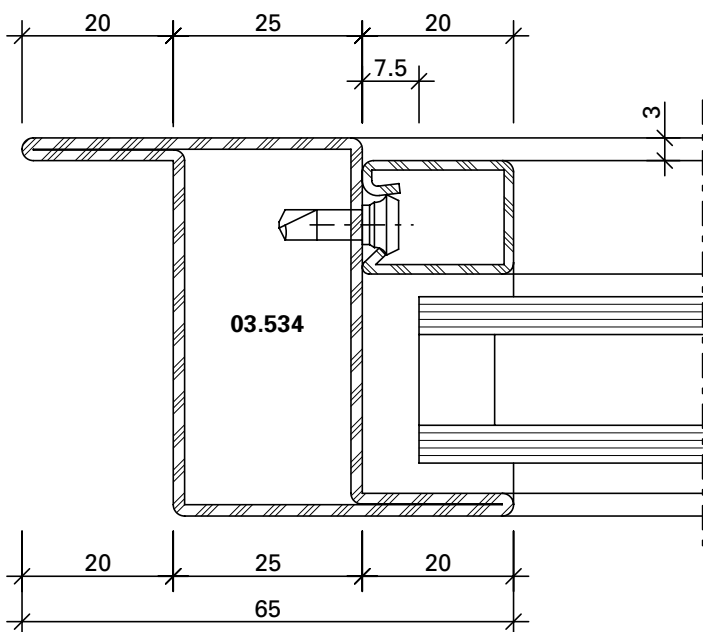

DXF **DWG** 23-0101-C-020

5.5

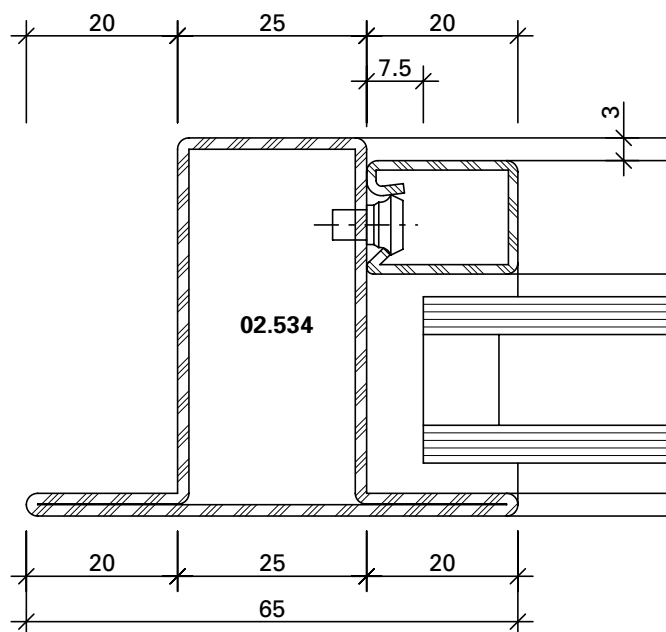

DXF **DWG** 23-0101-C-021

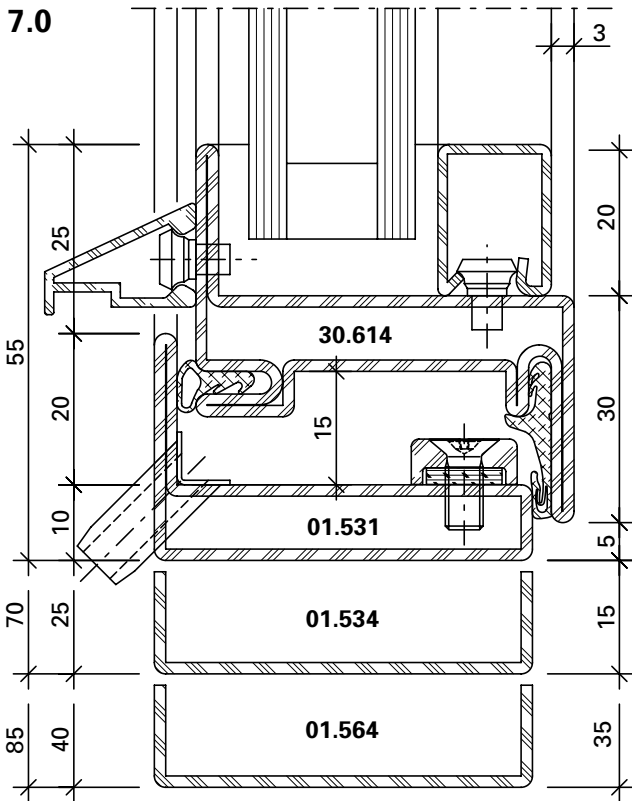

DWG

DXF

23-0101-C-022

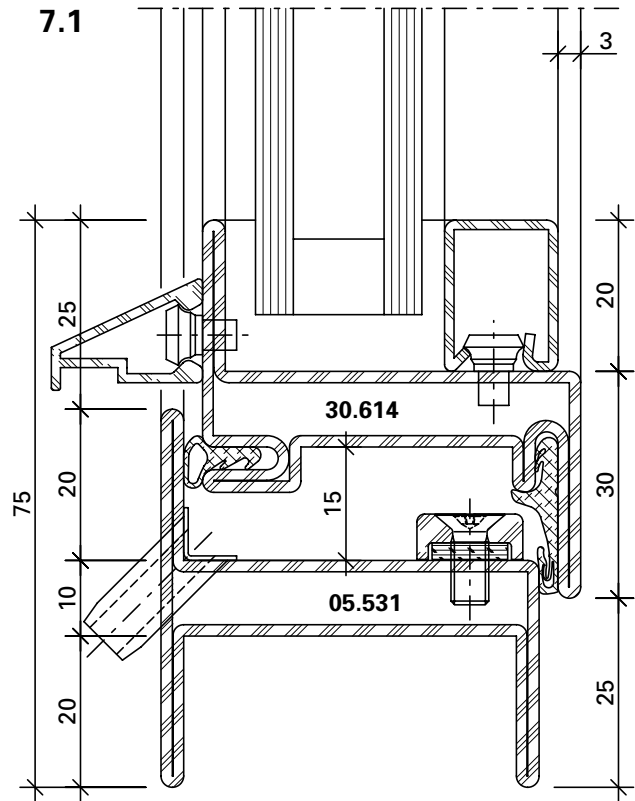

DWG

DXF

23-0101-C-023

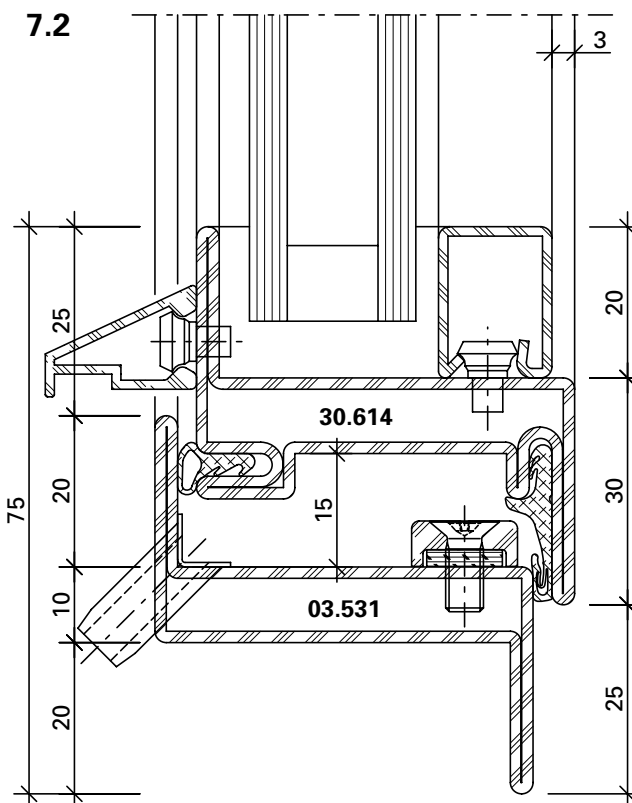

DWG

DXF

23-0101-C-024

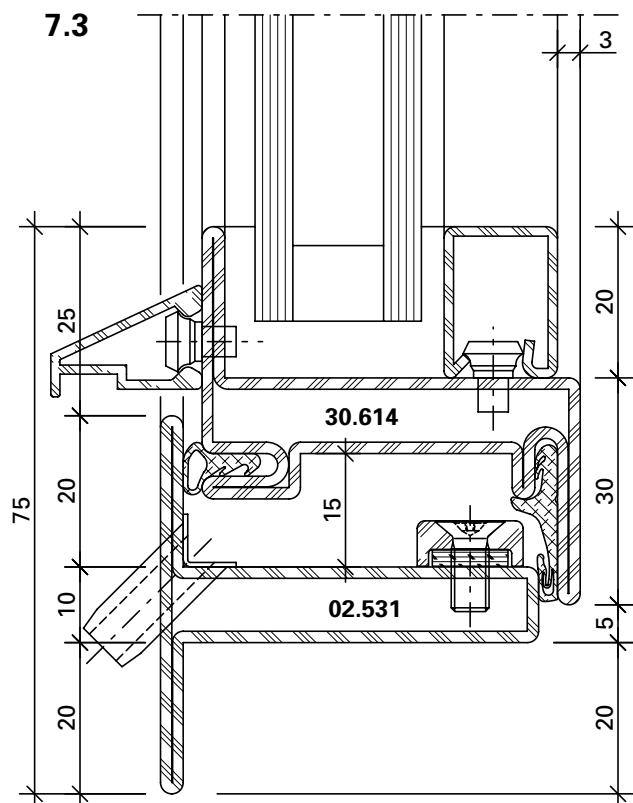

DWG

DXF

23-0101-C-025

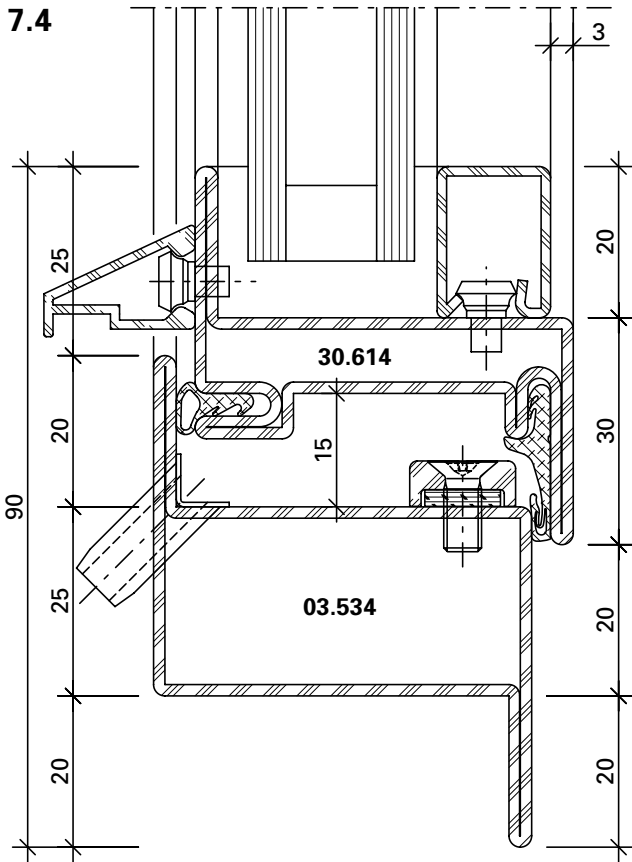

DWG

DXF

23-0101-C-026

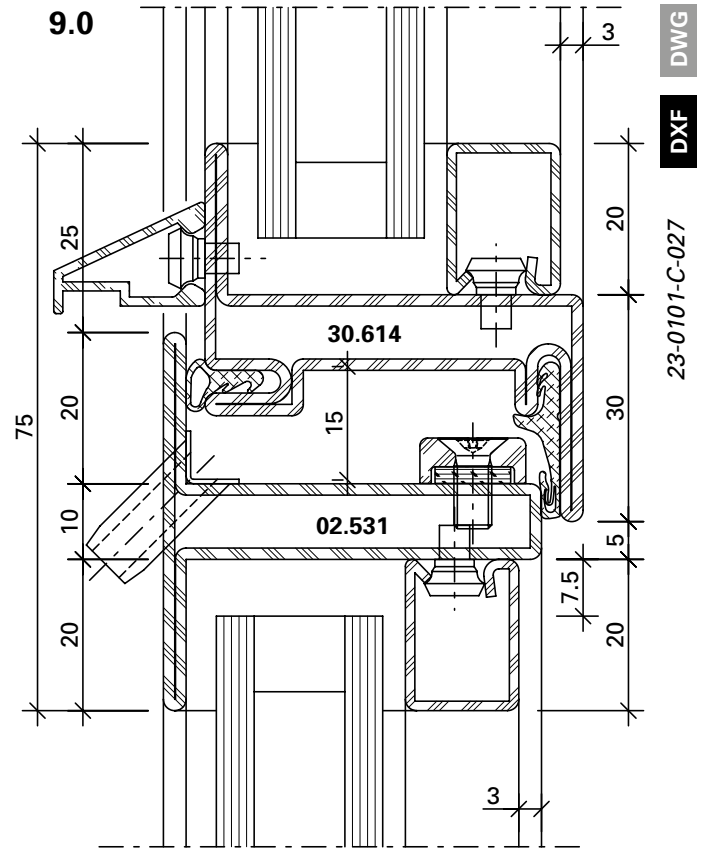

DWG

DXF

23-0101-C-027

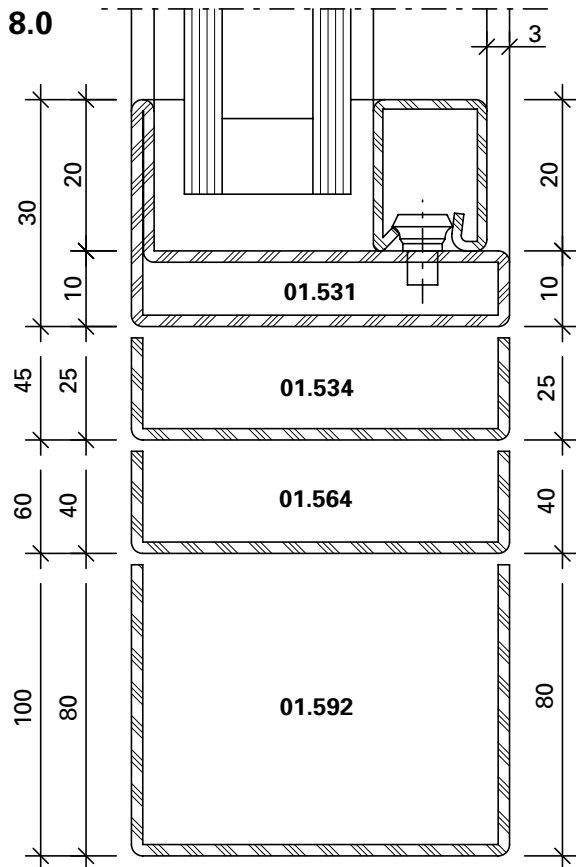

DWG

DXF

23-0101-C-028

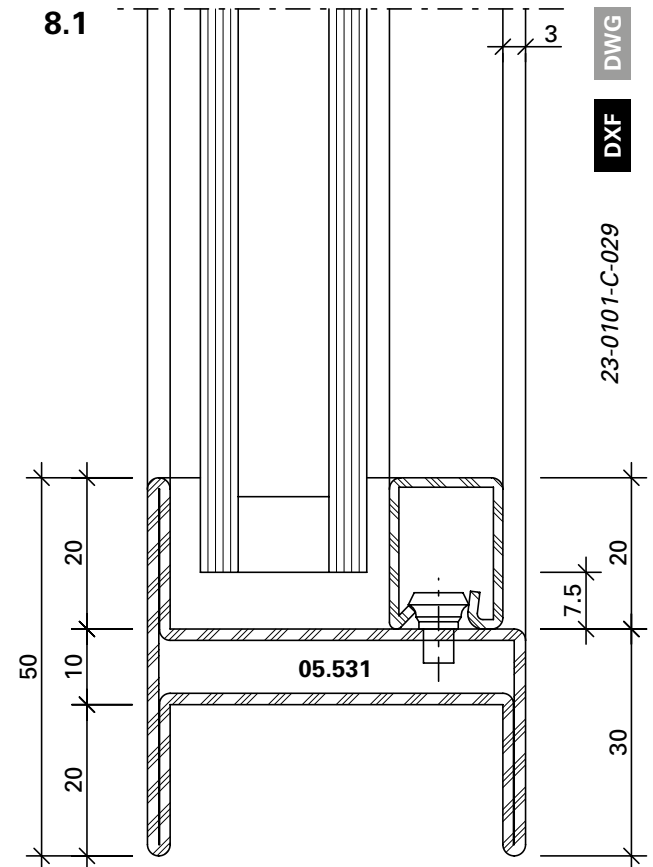

DWG

DXF

23-0101-C-029

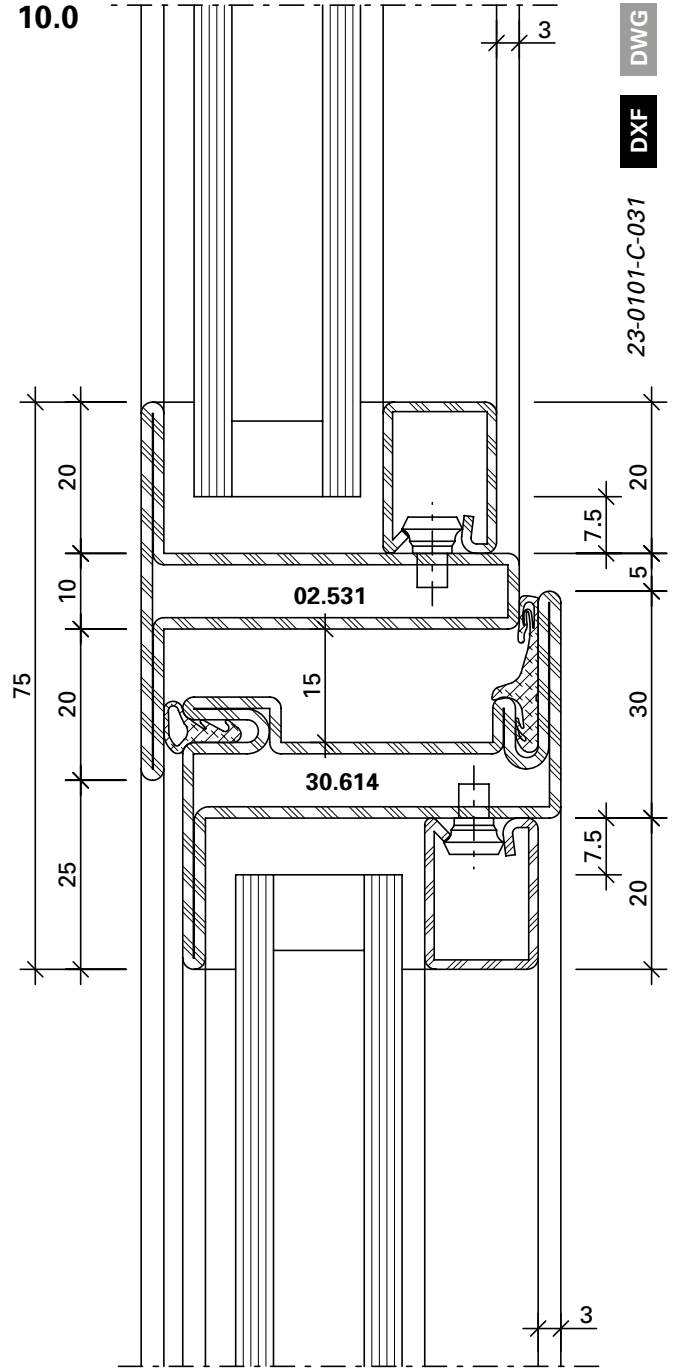
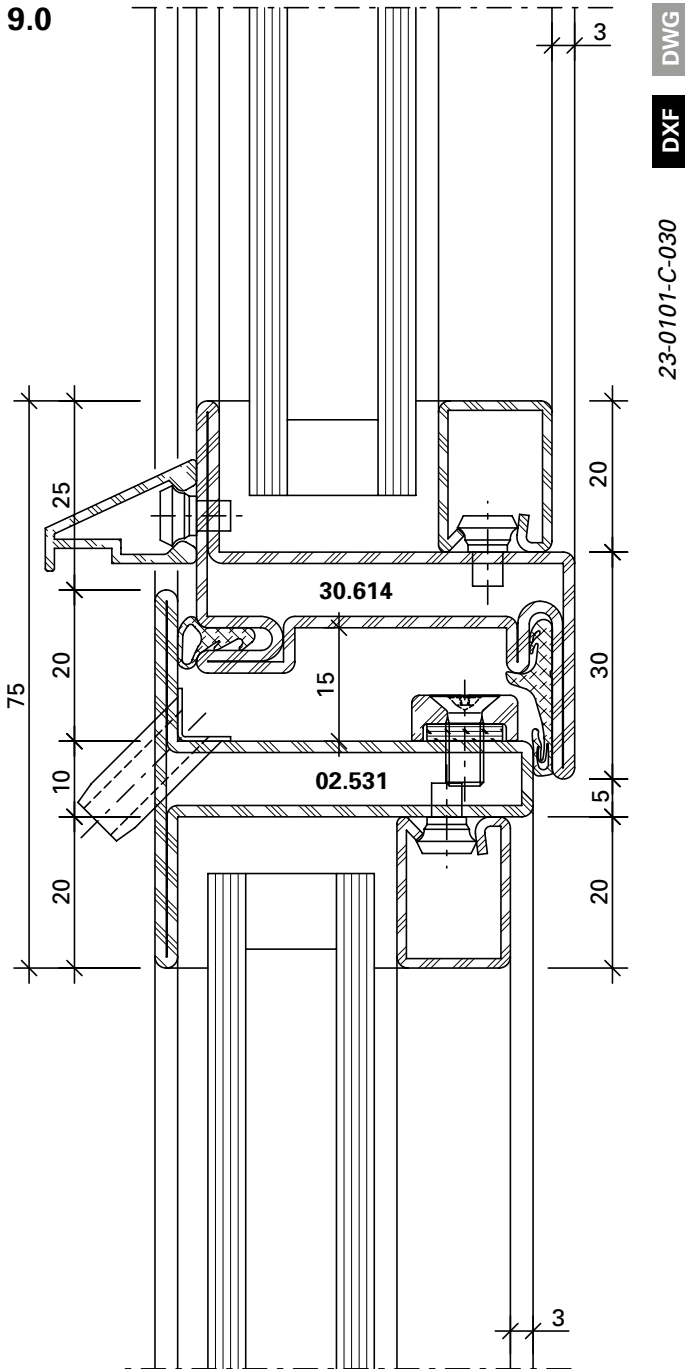

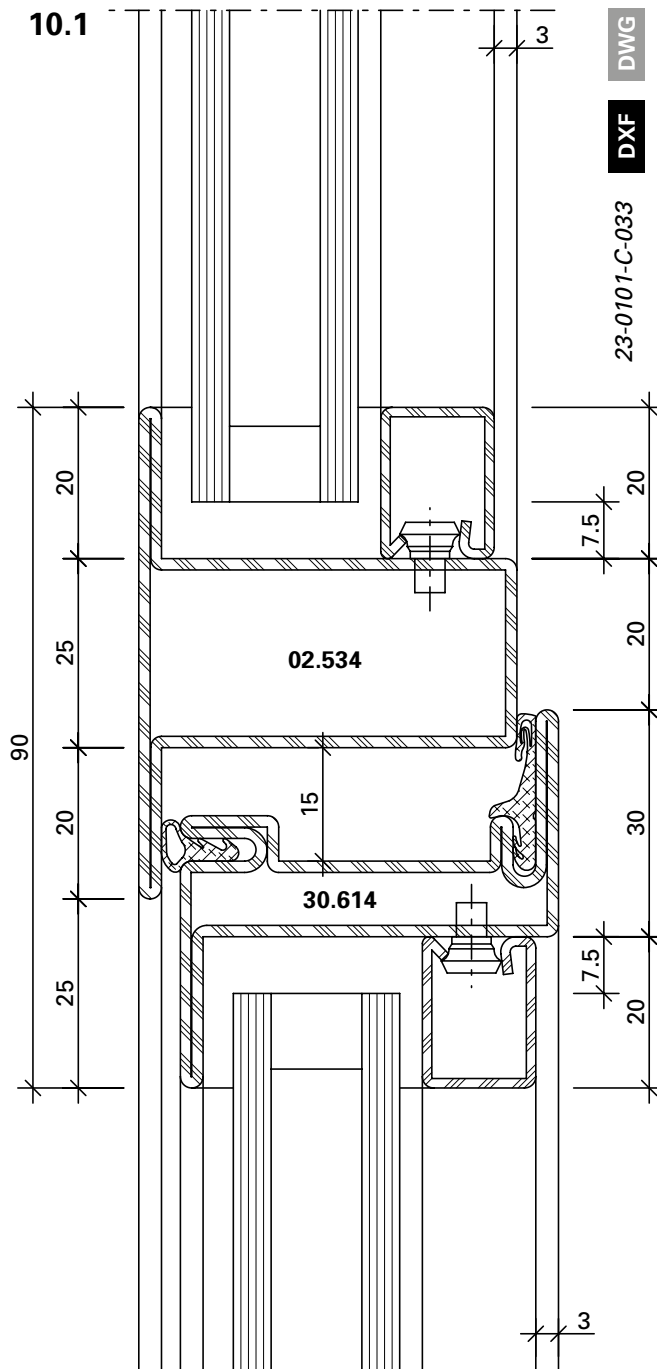
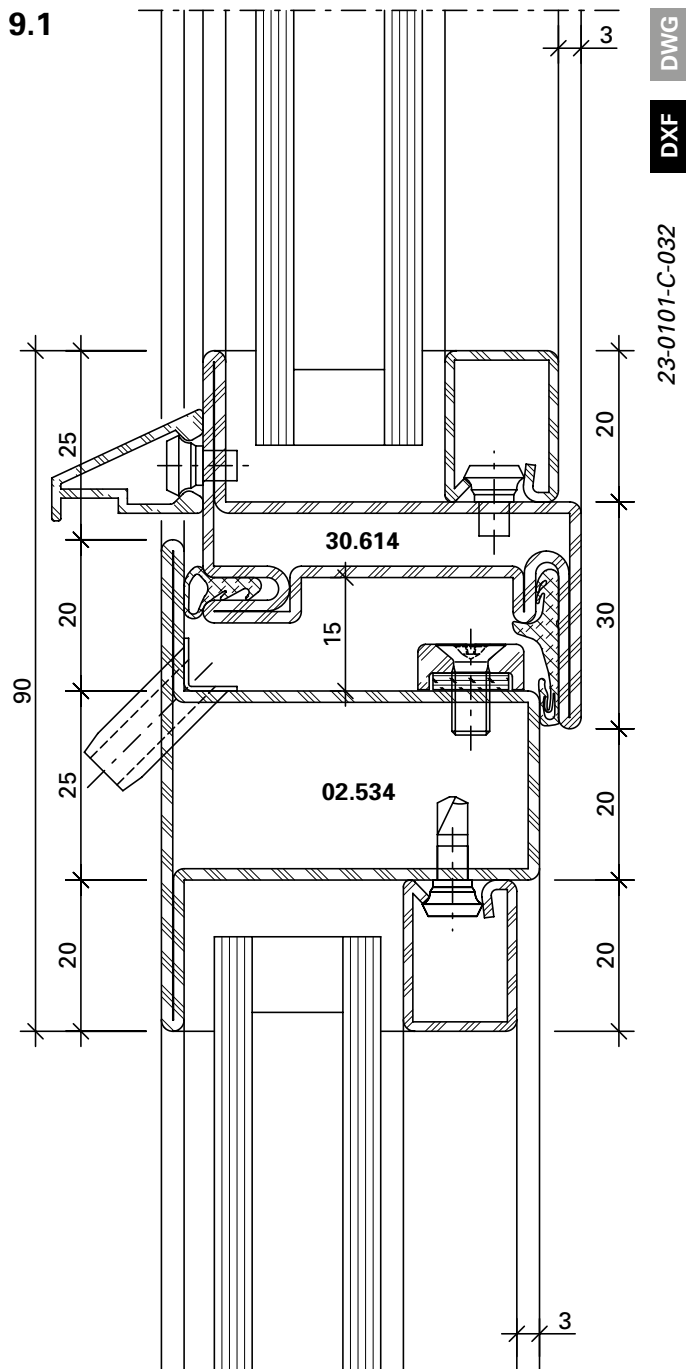

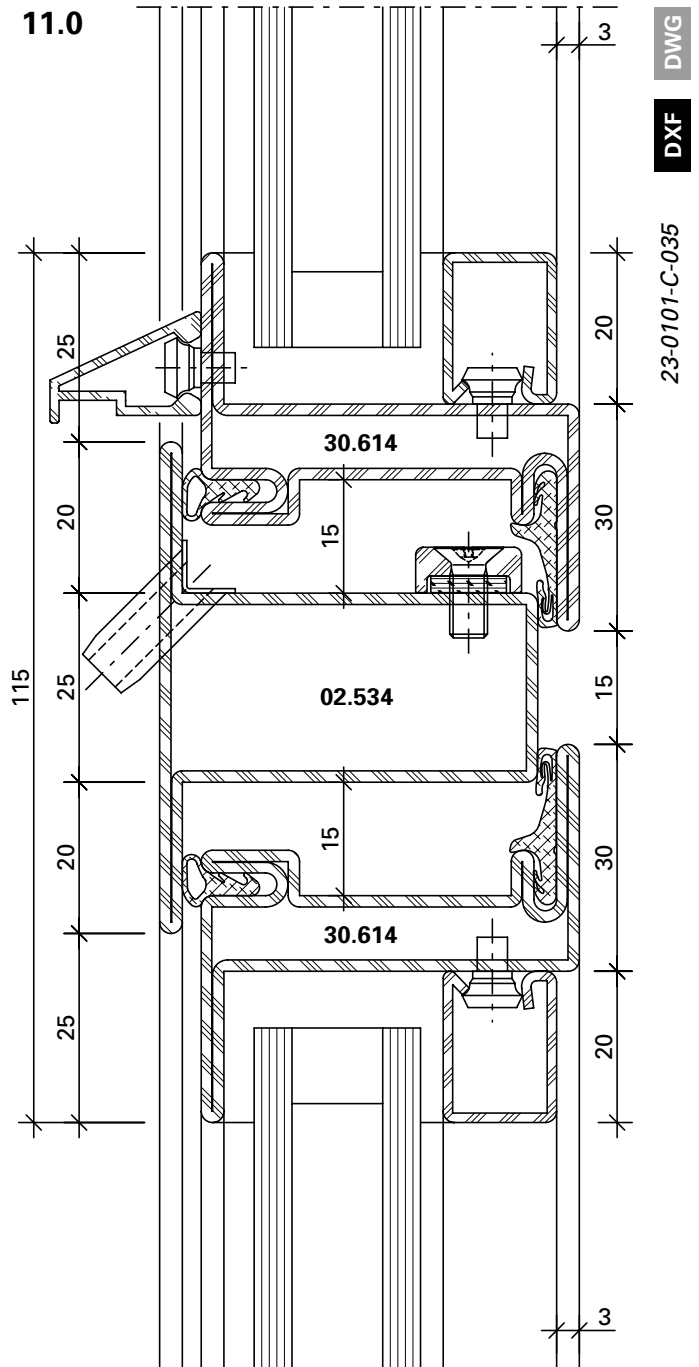
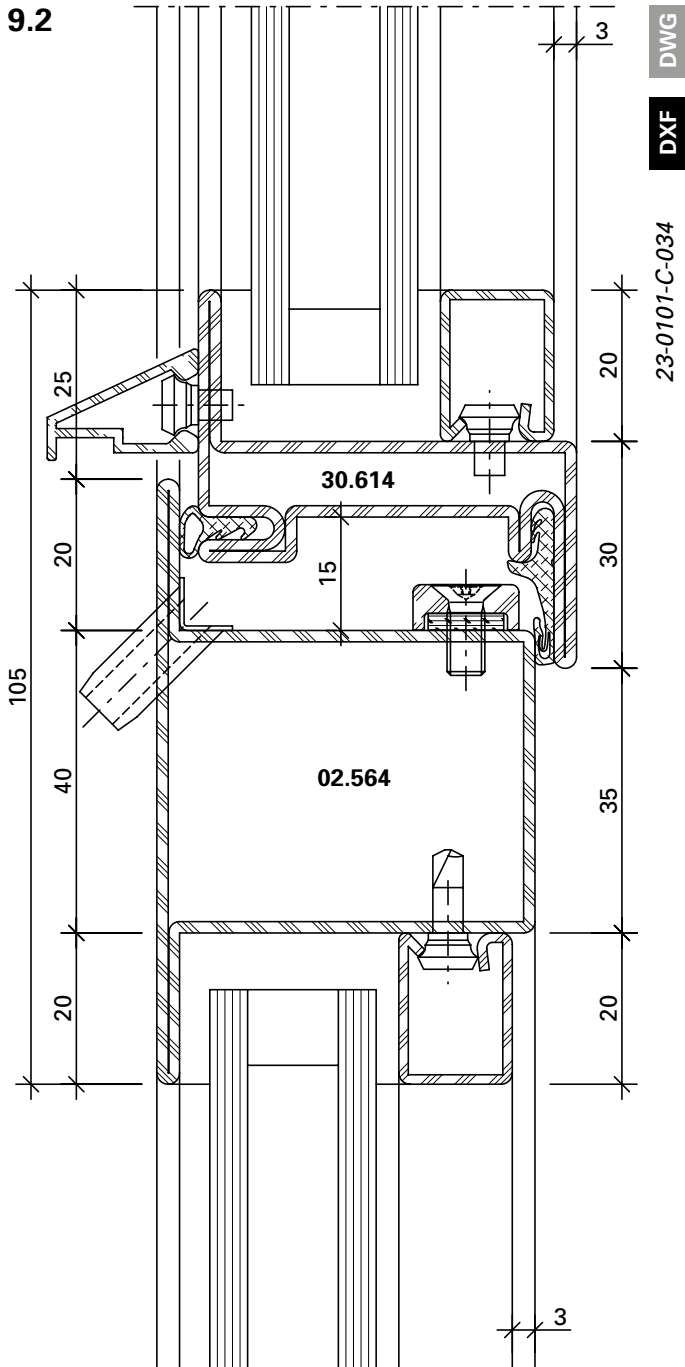

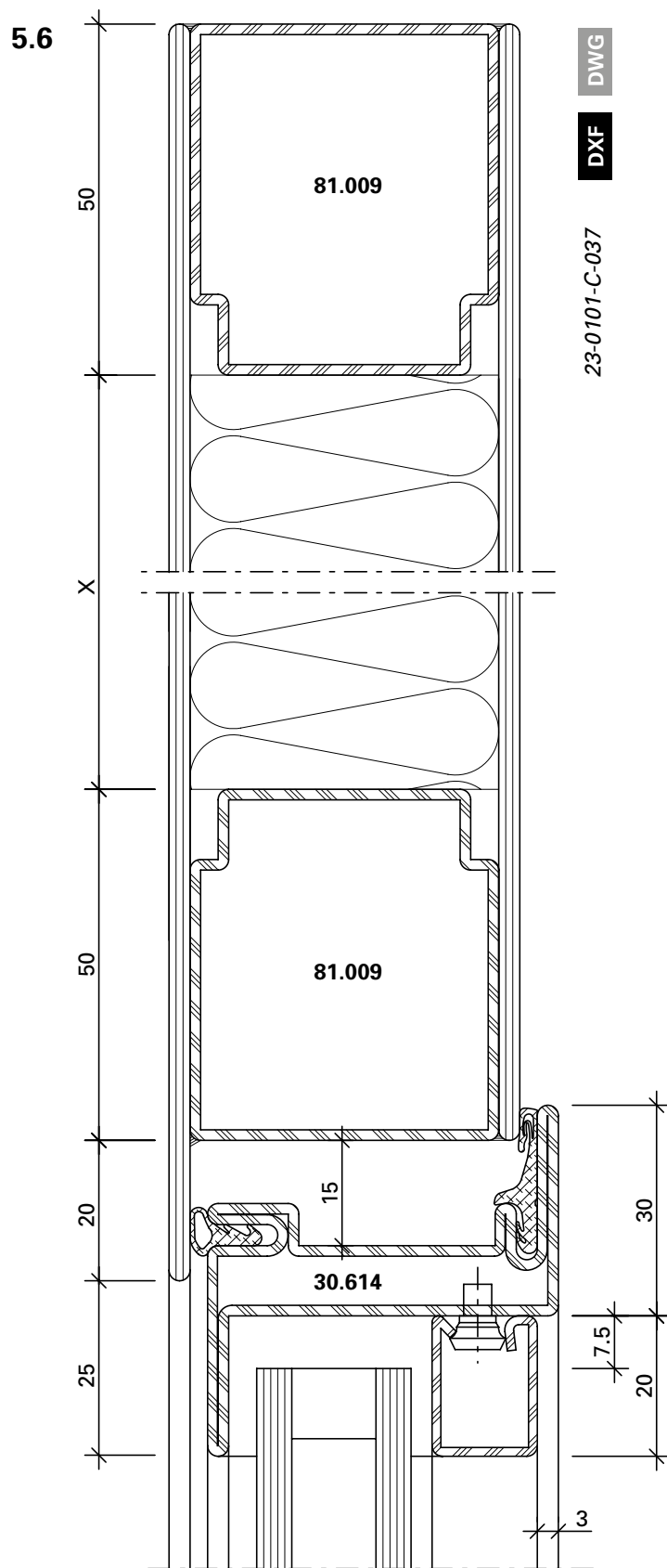
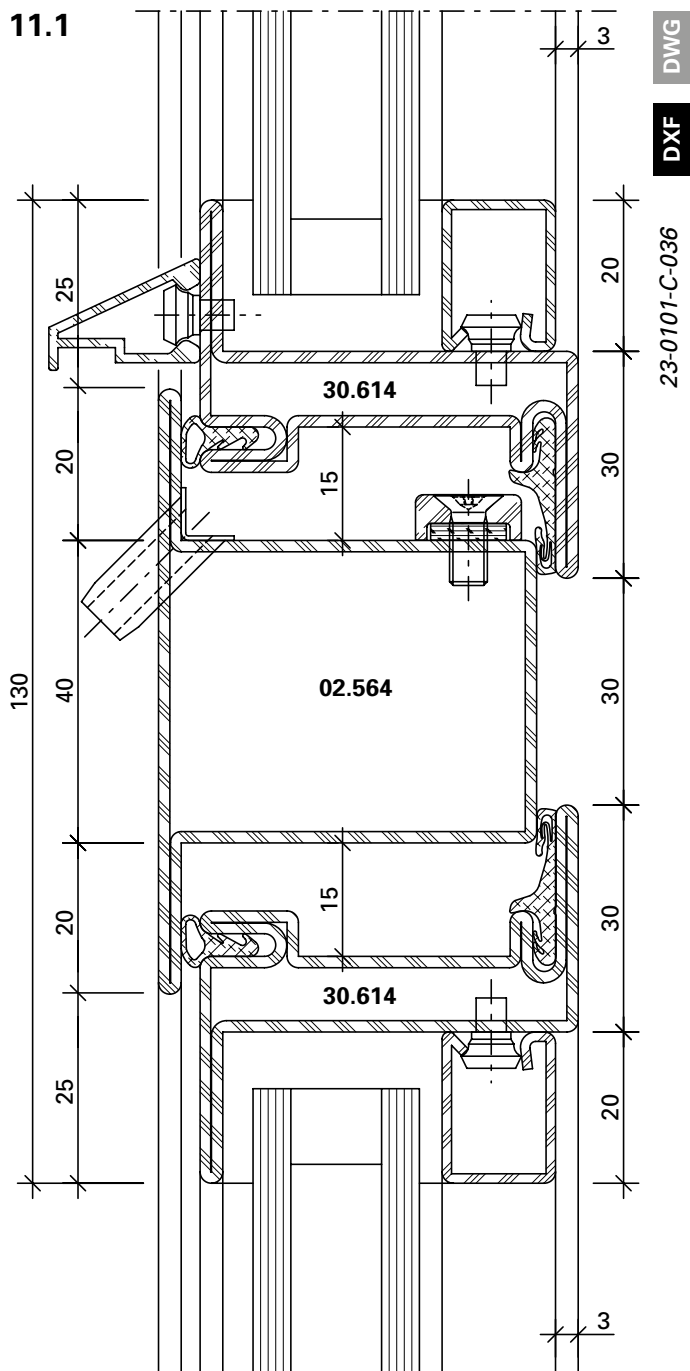

**Fenstertüren
 mit Schloss und Drücker***

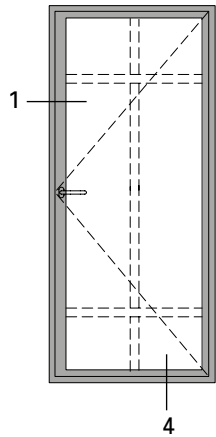

**Portes-fenêtres
 avec serrure et poignée***

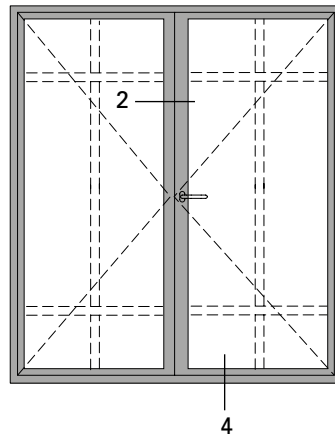

**Windows-doors
 with lock and handle***

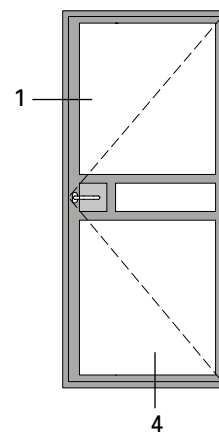
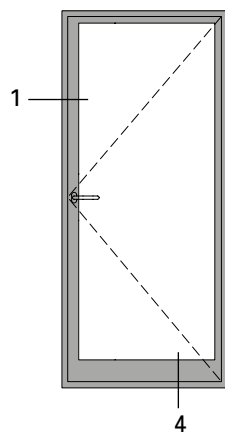
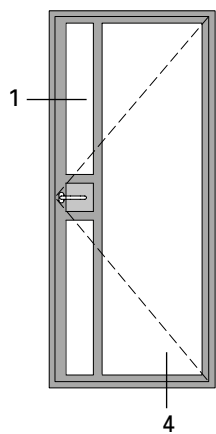
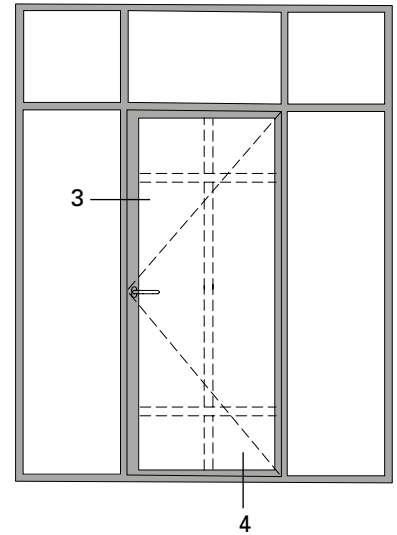

* Sonderkonstruktion
 (nach Produktnorm EN 14351
 nicht geprüft)

* Construction spéciale
 (non contrôlé selon la norme
 produit EN 14351)

* Special construction
 (not tested in accordance with
 the EN 14351 product standard)

1.0

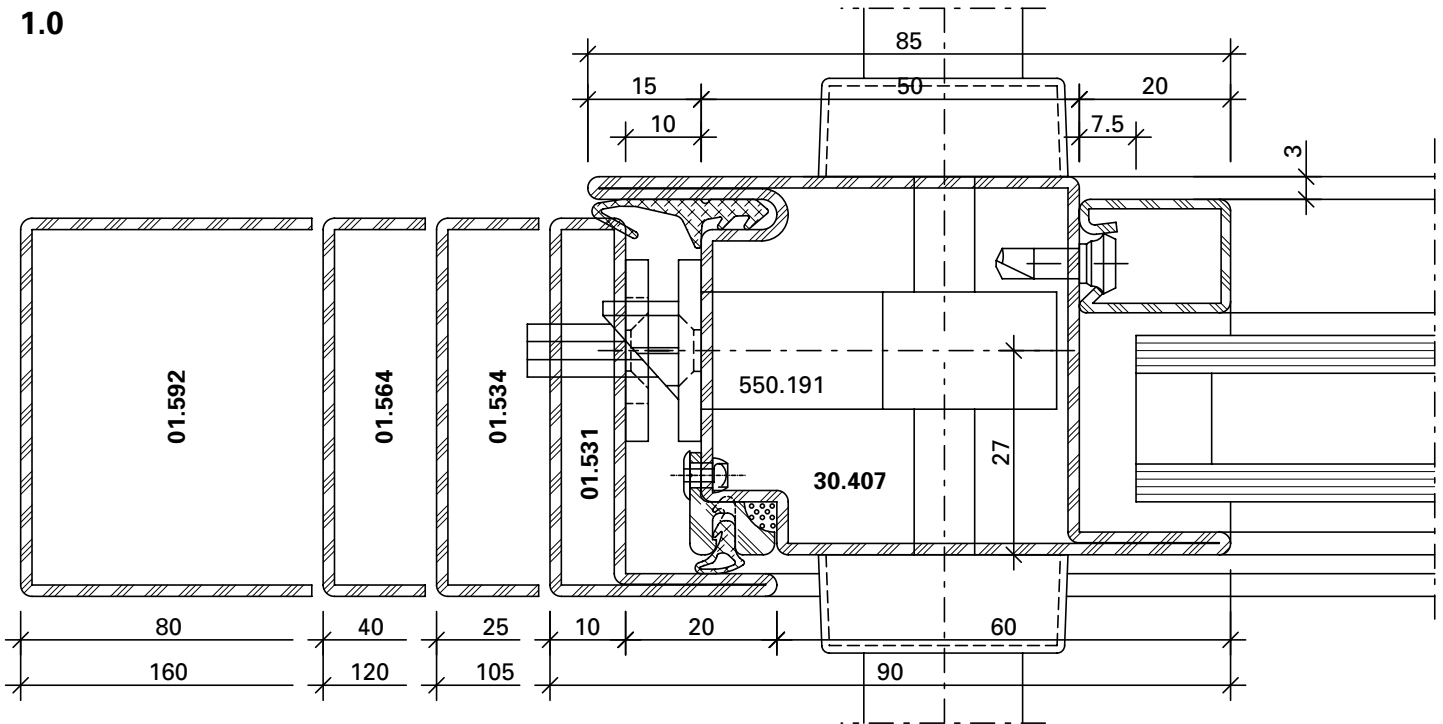

DXF **DWG** 23-0101-C-038

1.1

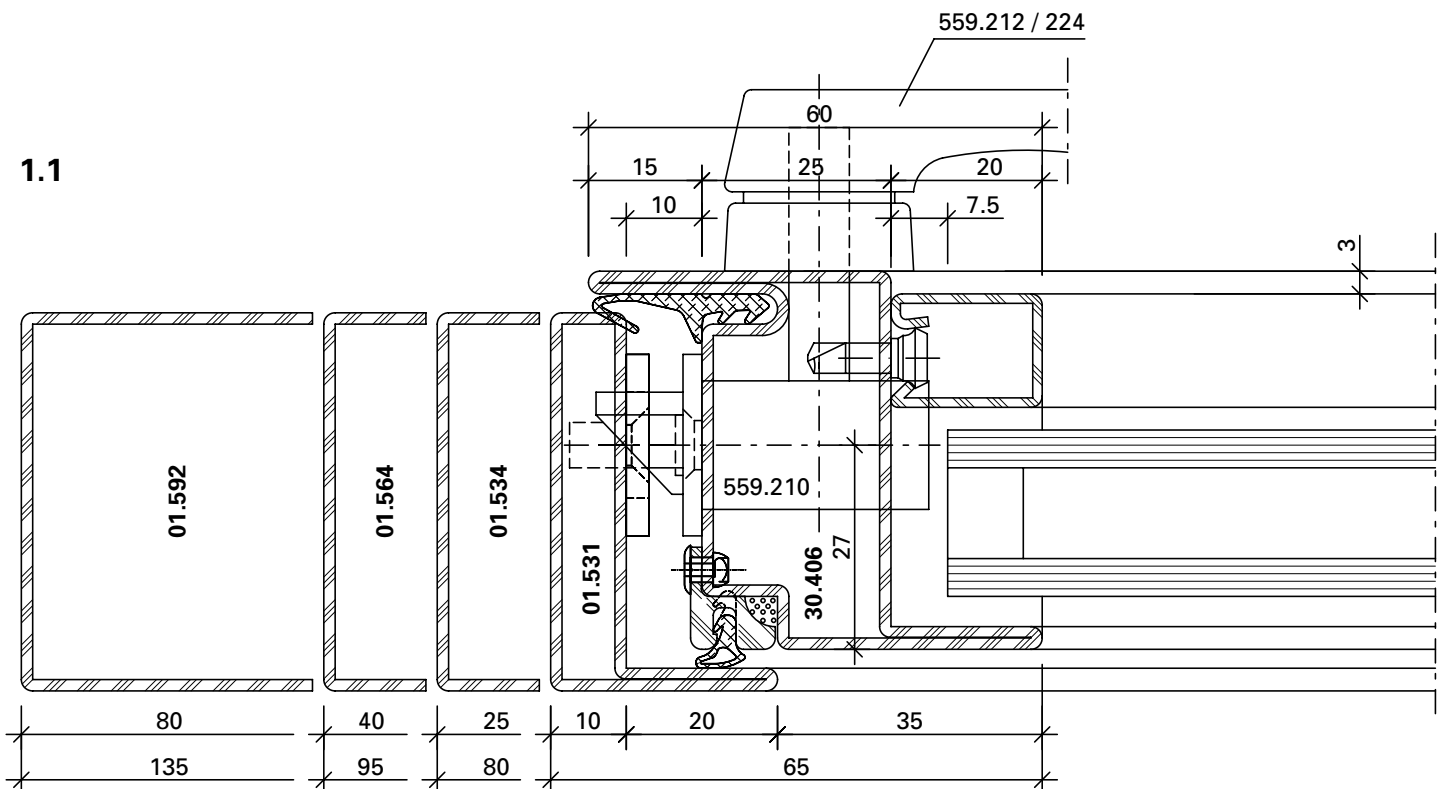

DXF **DWG** 23-0101-C-039

2.0

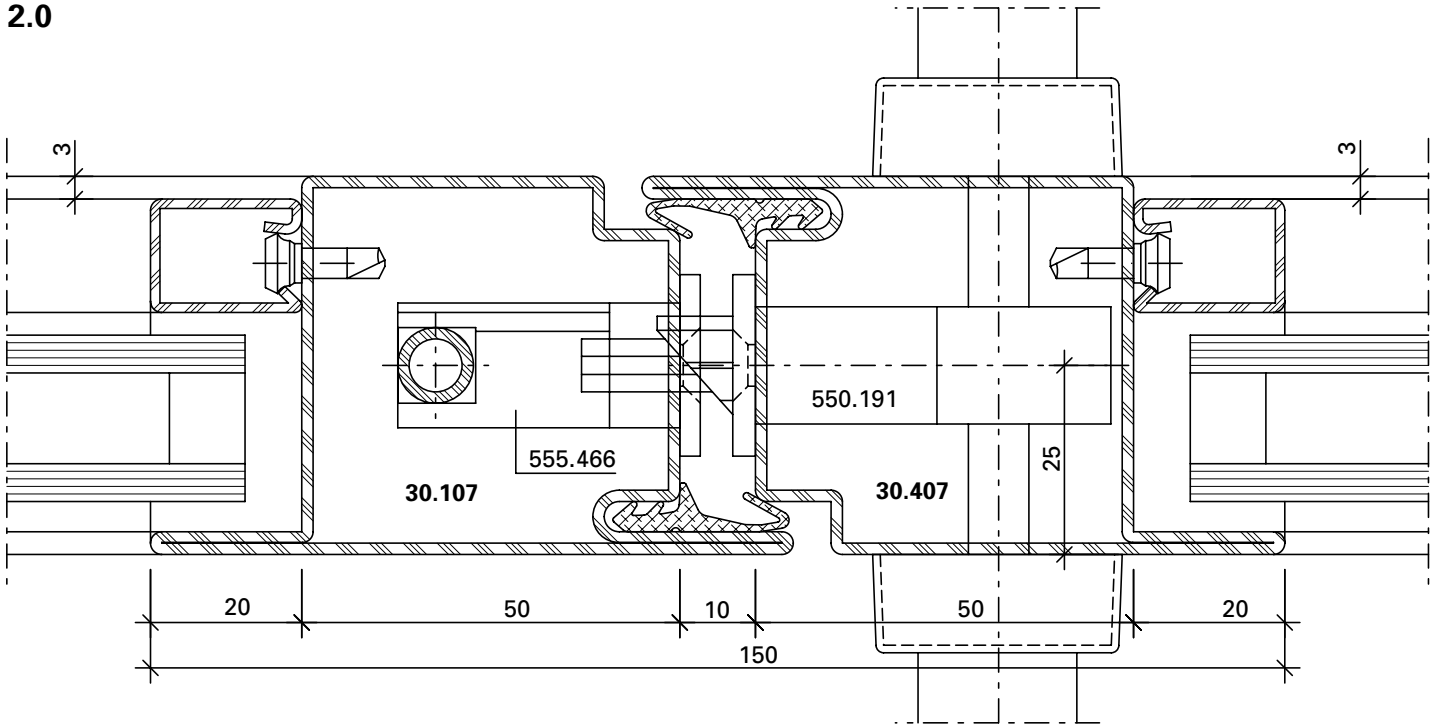

DXF

DWG

23-0101-C-040

3.0

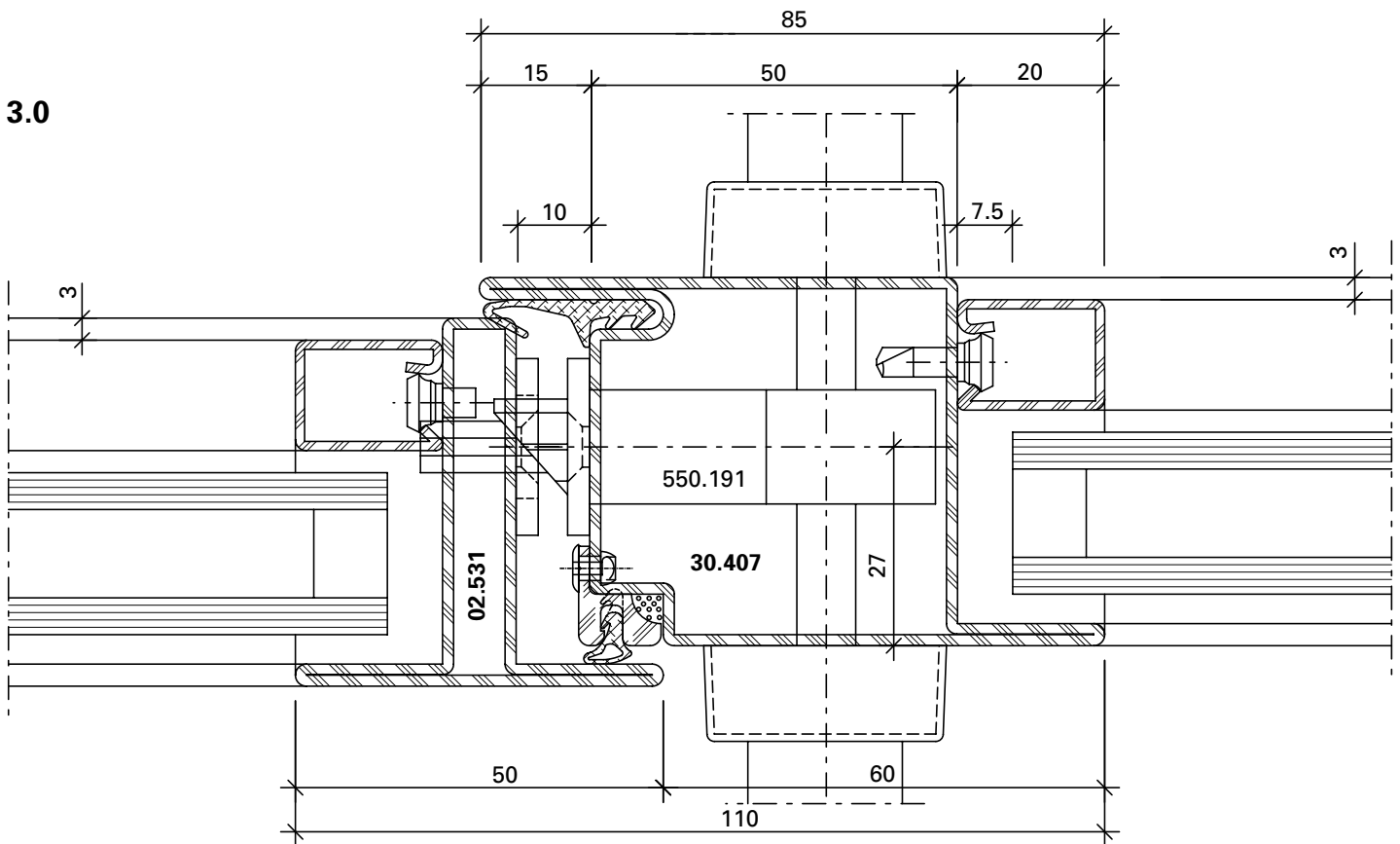

DXF

DWG

23-0101-C-041

2.1

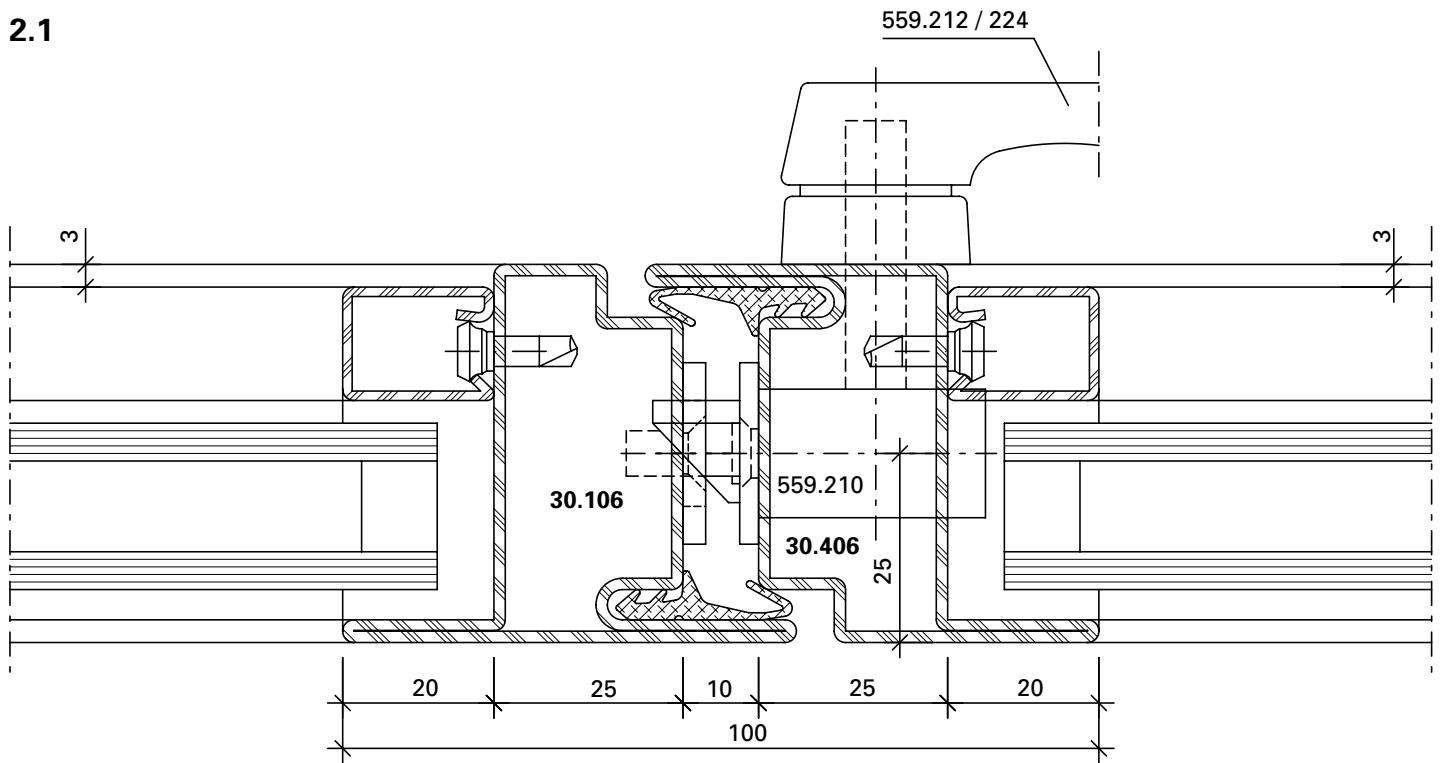

DXF **DWG** 23-0101-C-042

3.1

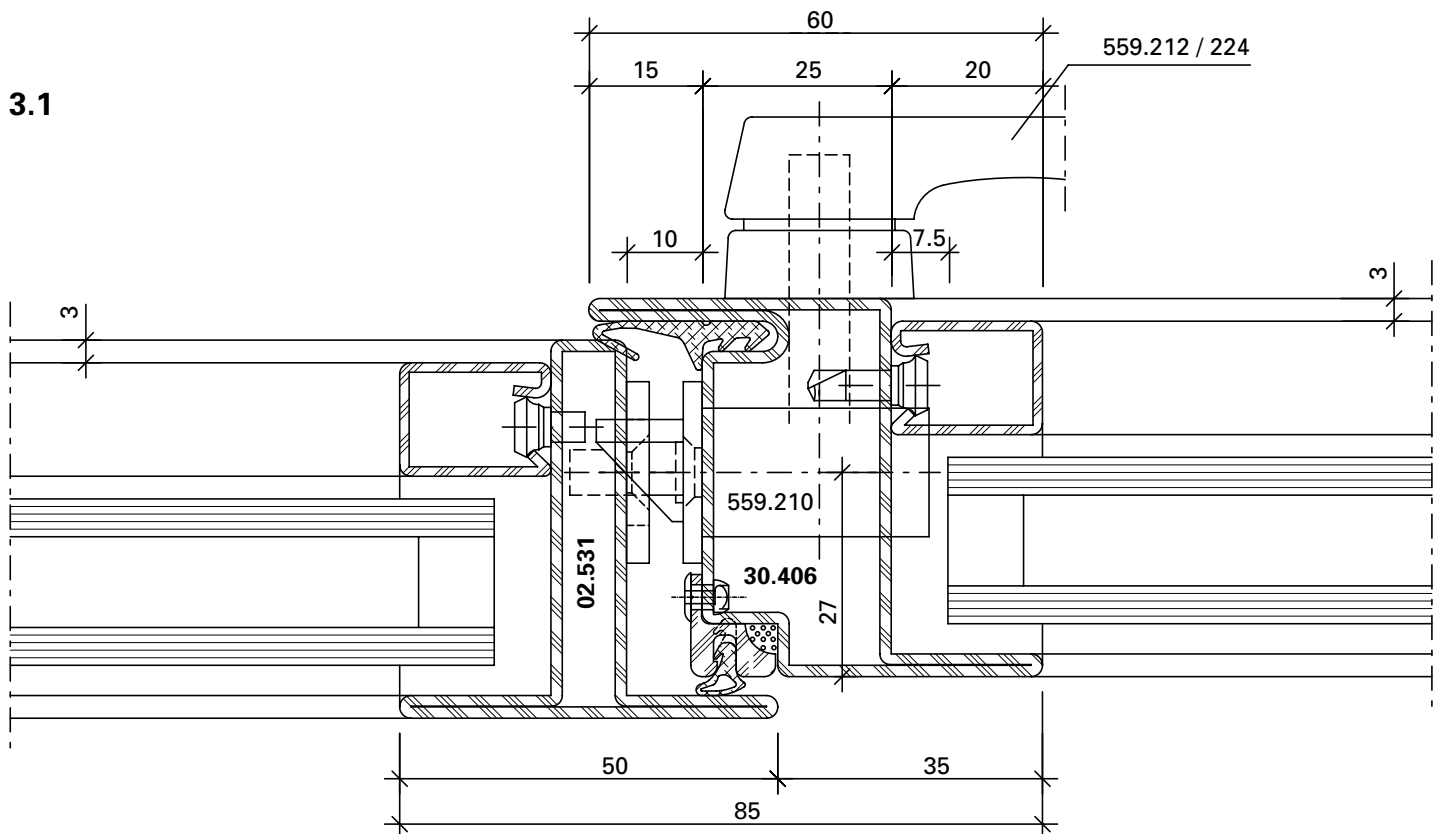

DXF **DWG** 23-0101-C-043

Nur für Markt Frankreich

Seulement pour marché France

Only for the French market

1.2

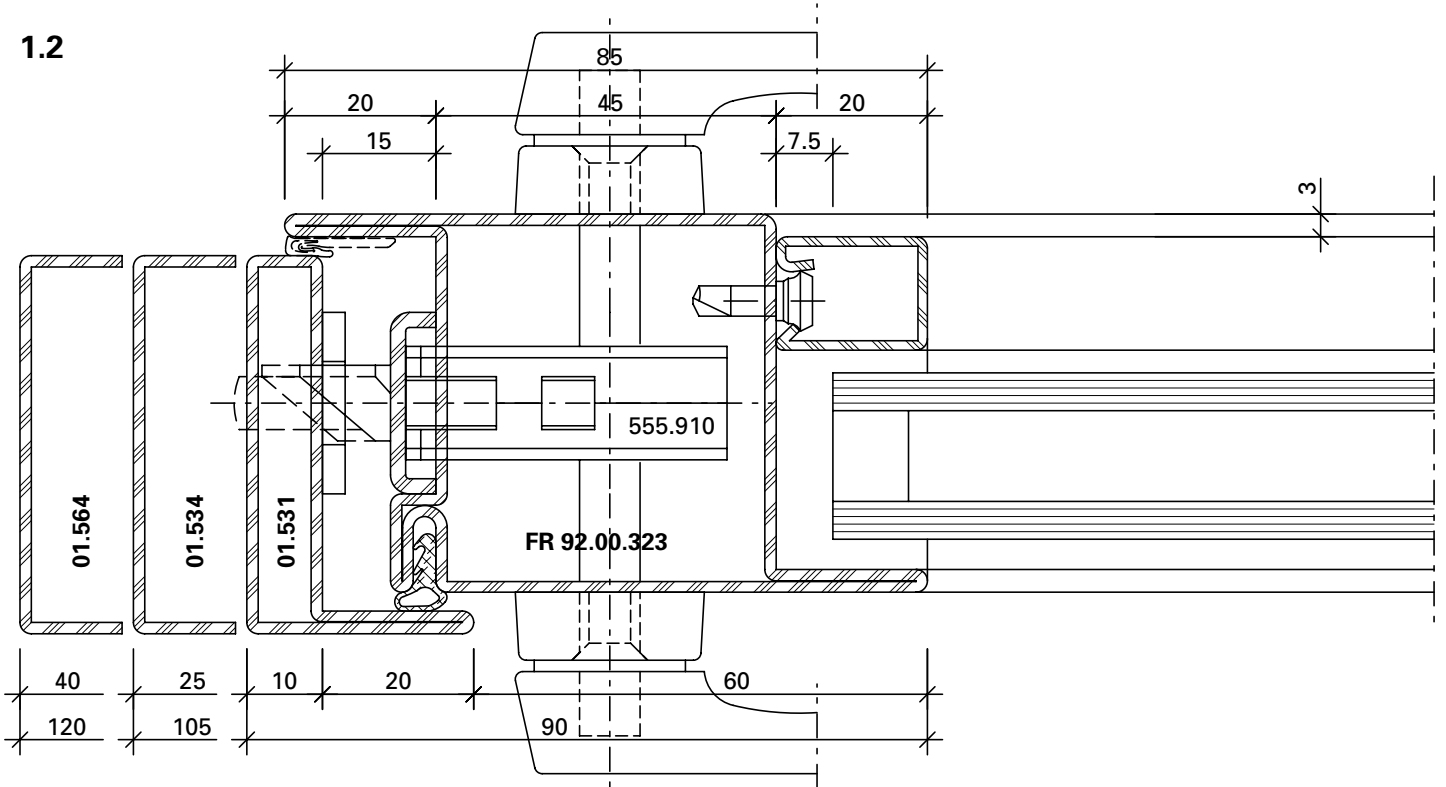

DXF DWG 23-0101-C-044

3.2

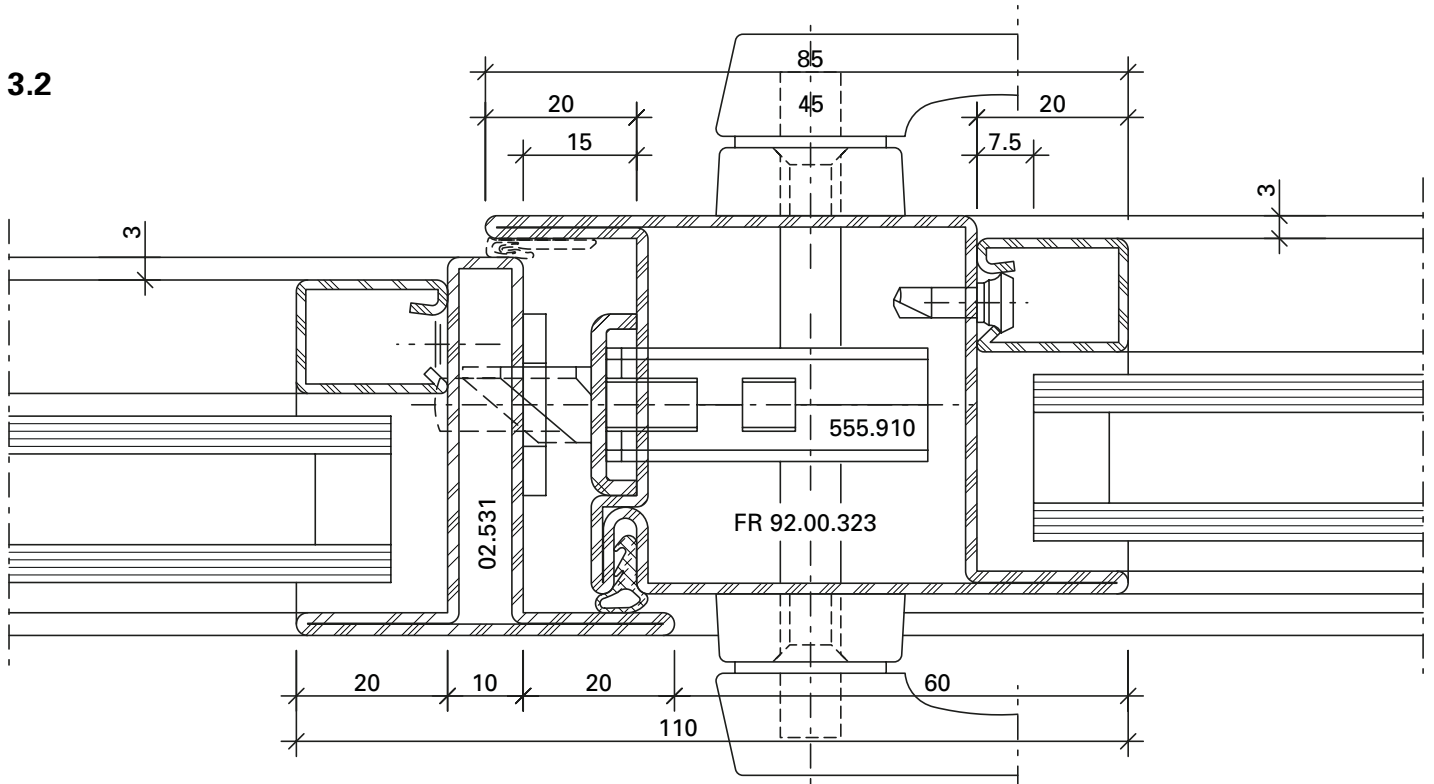

DXF DWG 23-0101-C-058

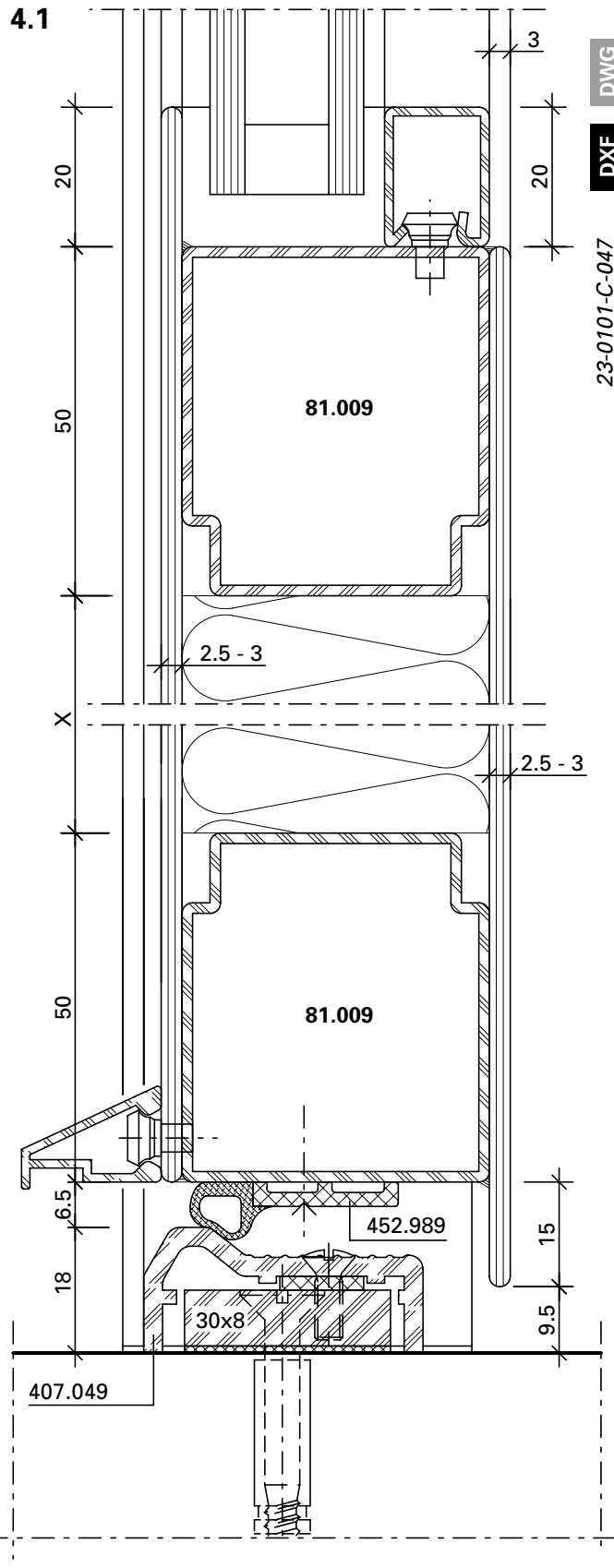
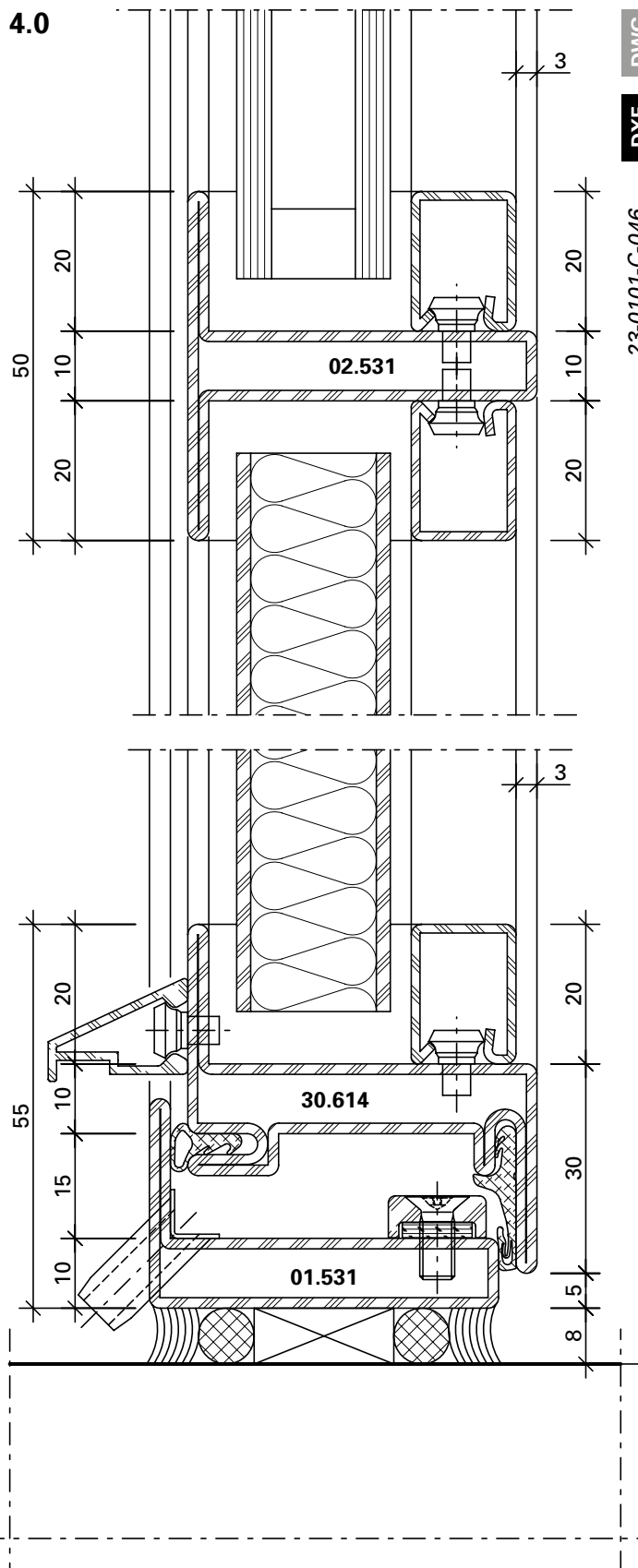

4.2

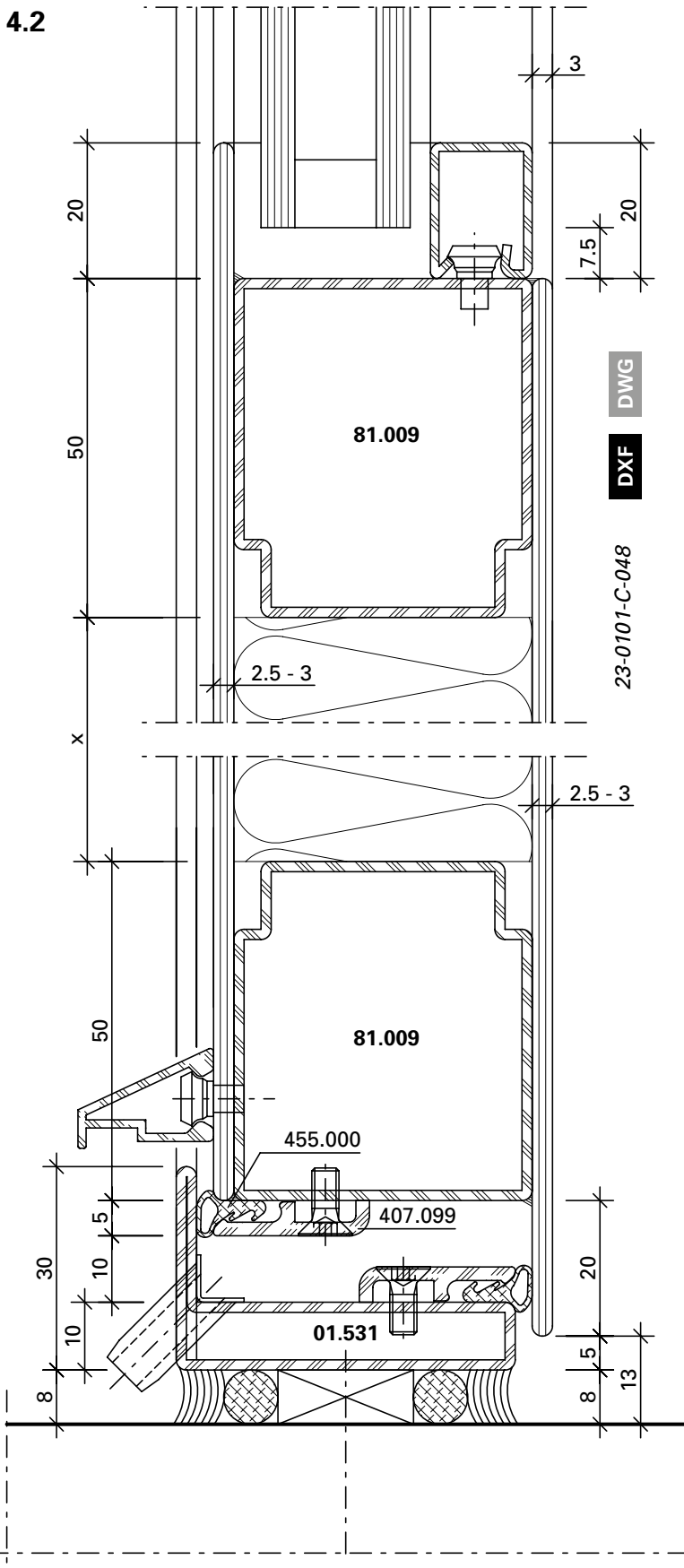

4.3

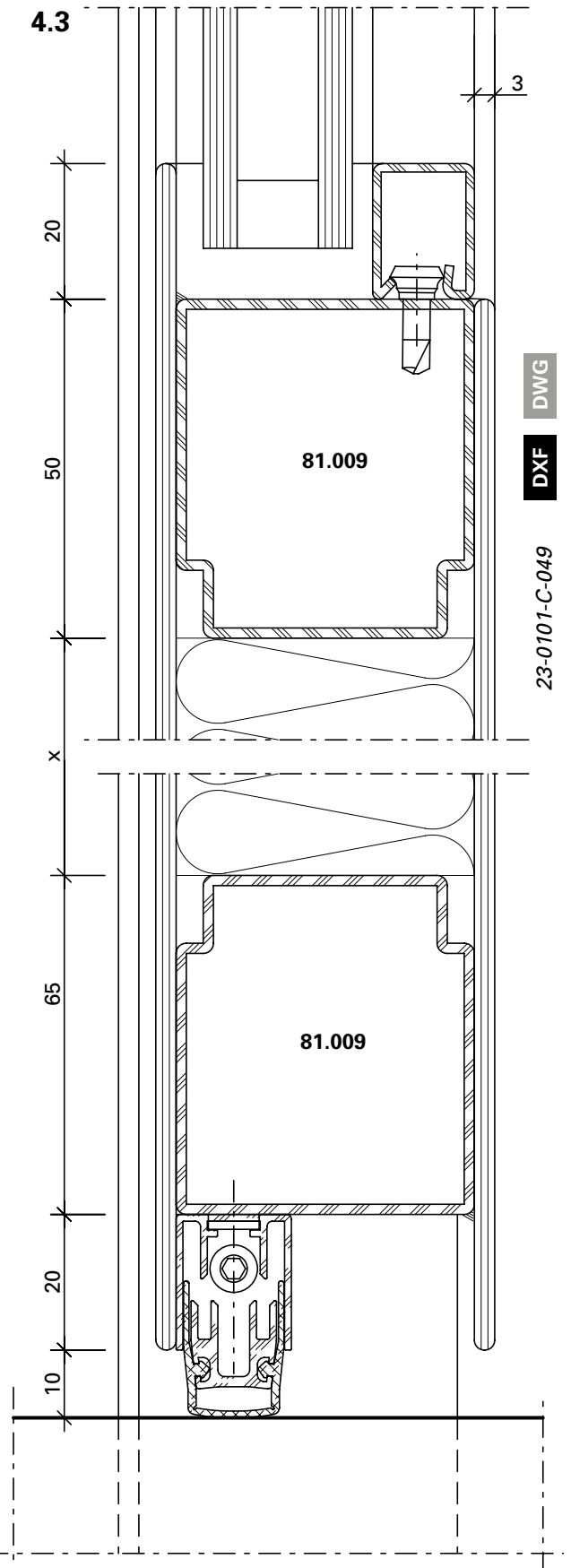

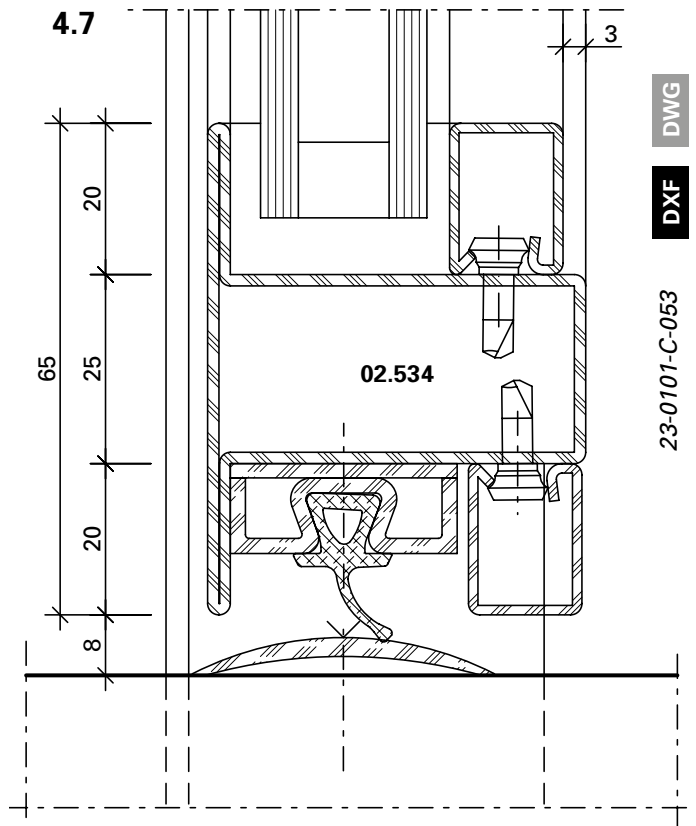
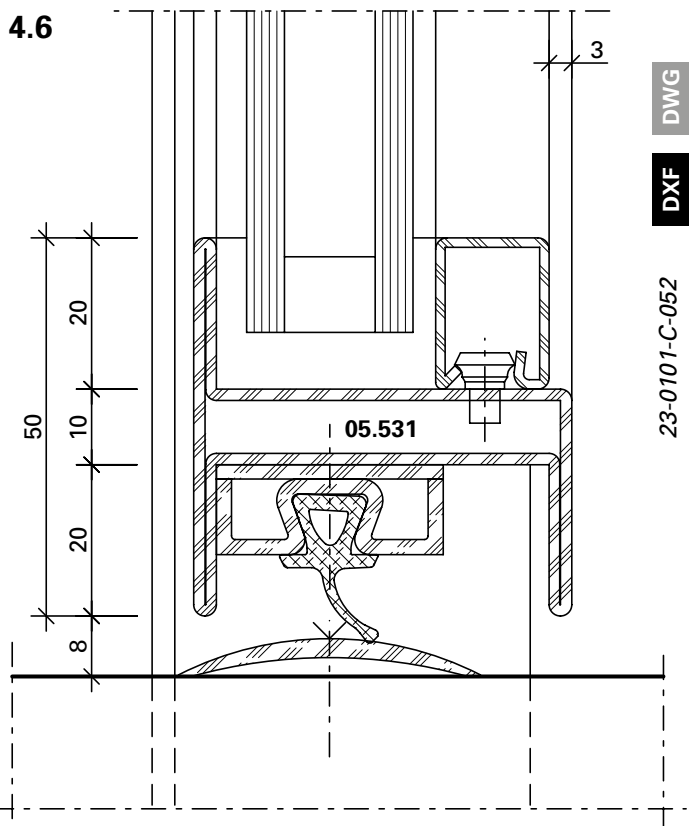
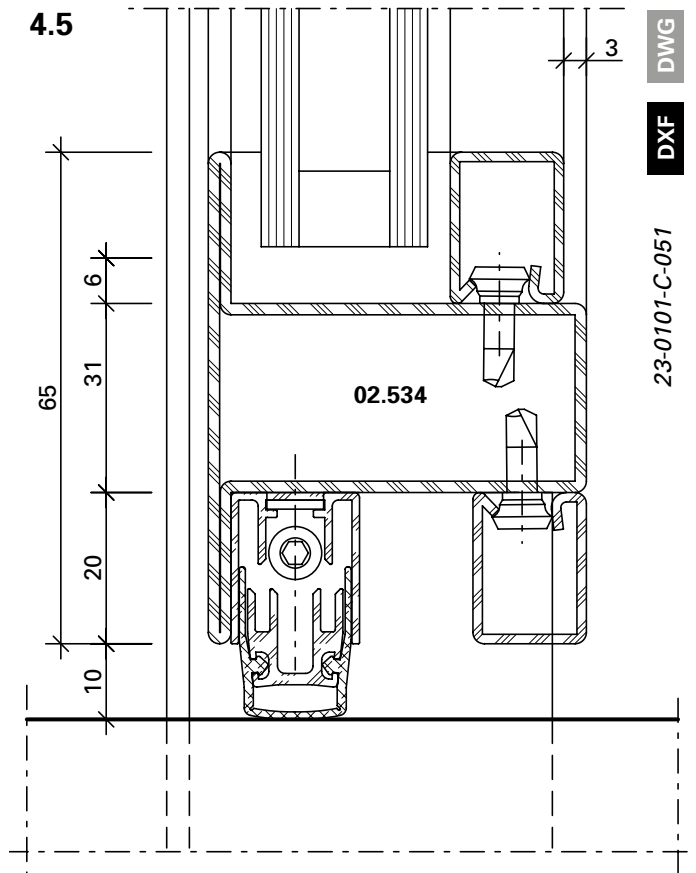
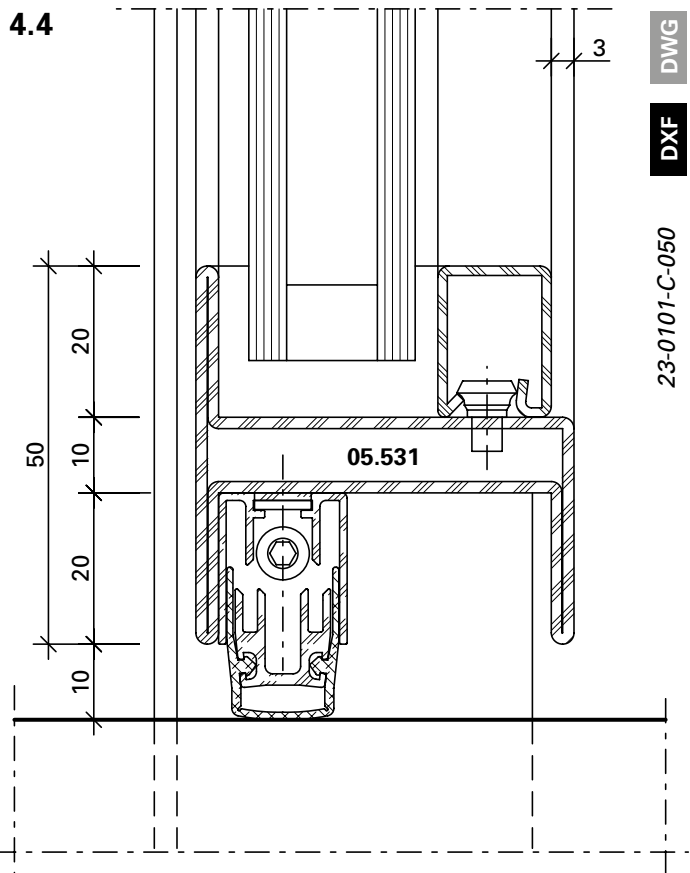

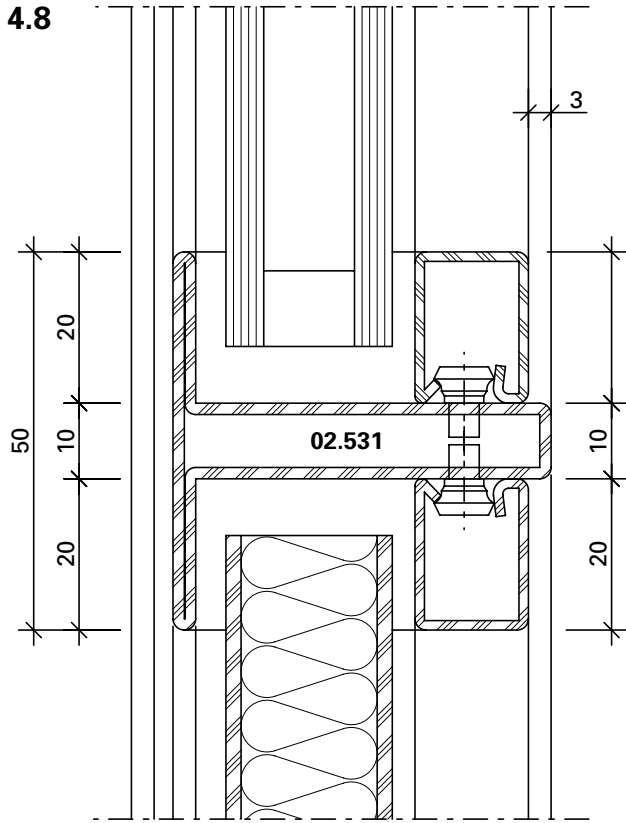

DWG

DXF

23-0101-C-054

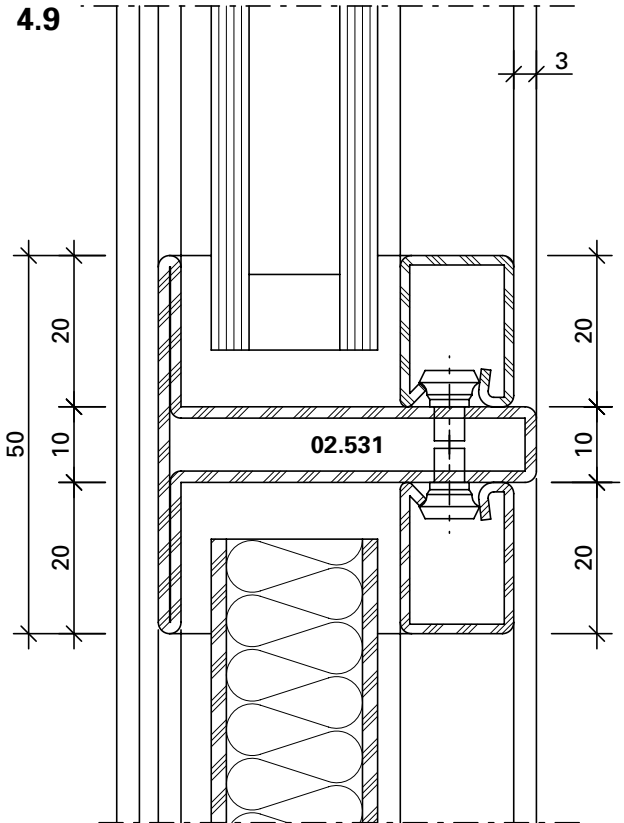

DWG

DXF

23-0101-C-055

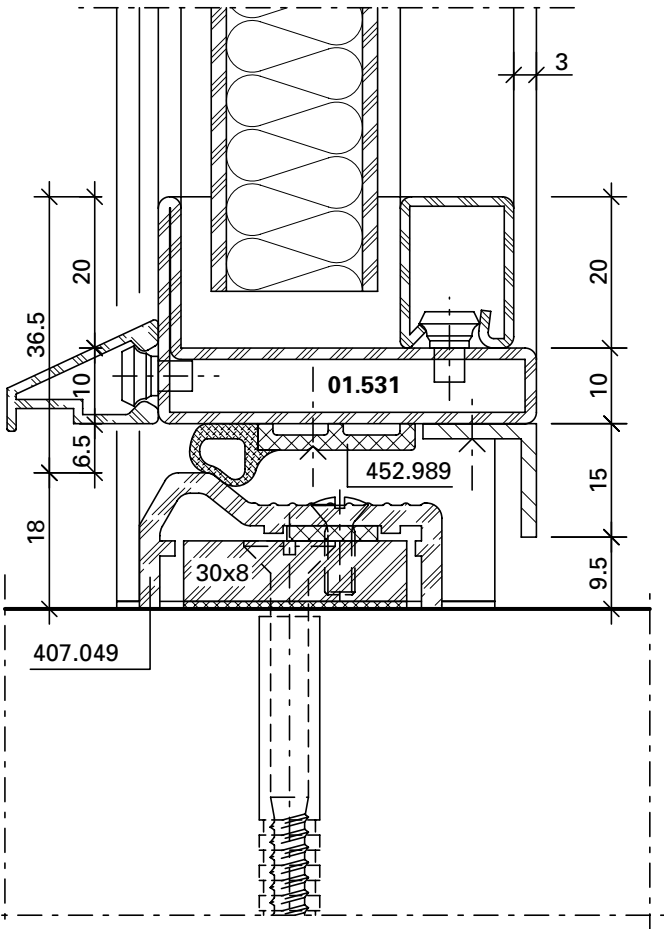
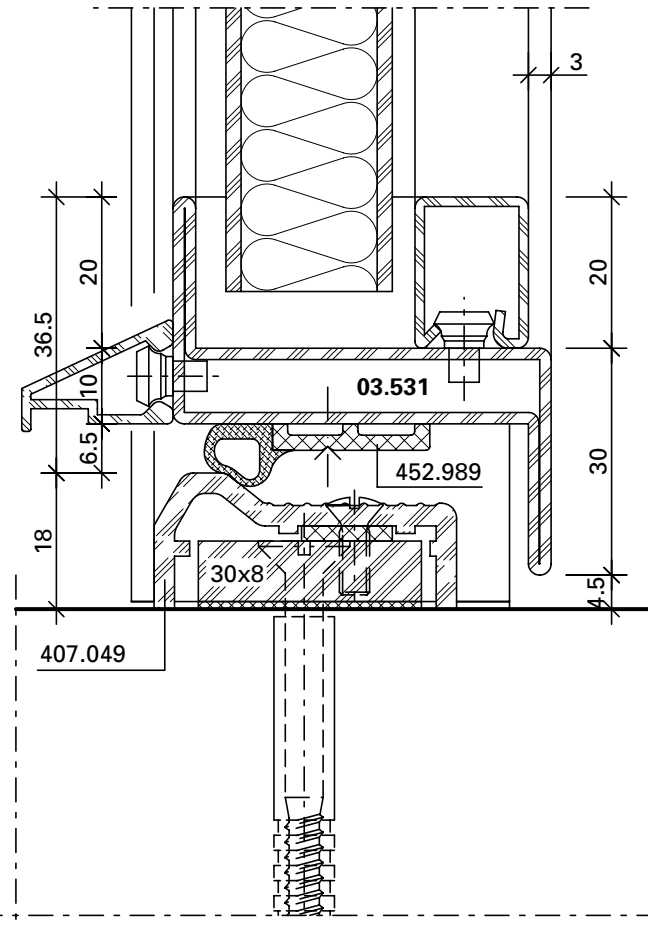

4.10

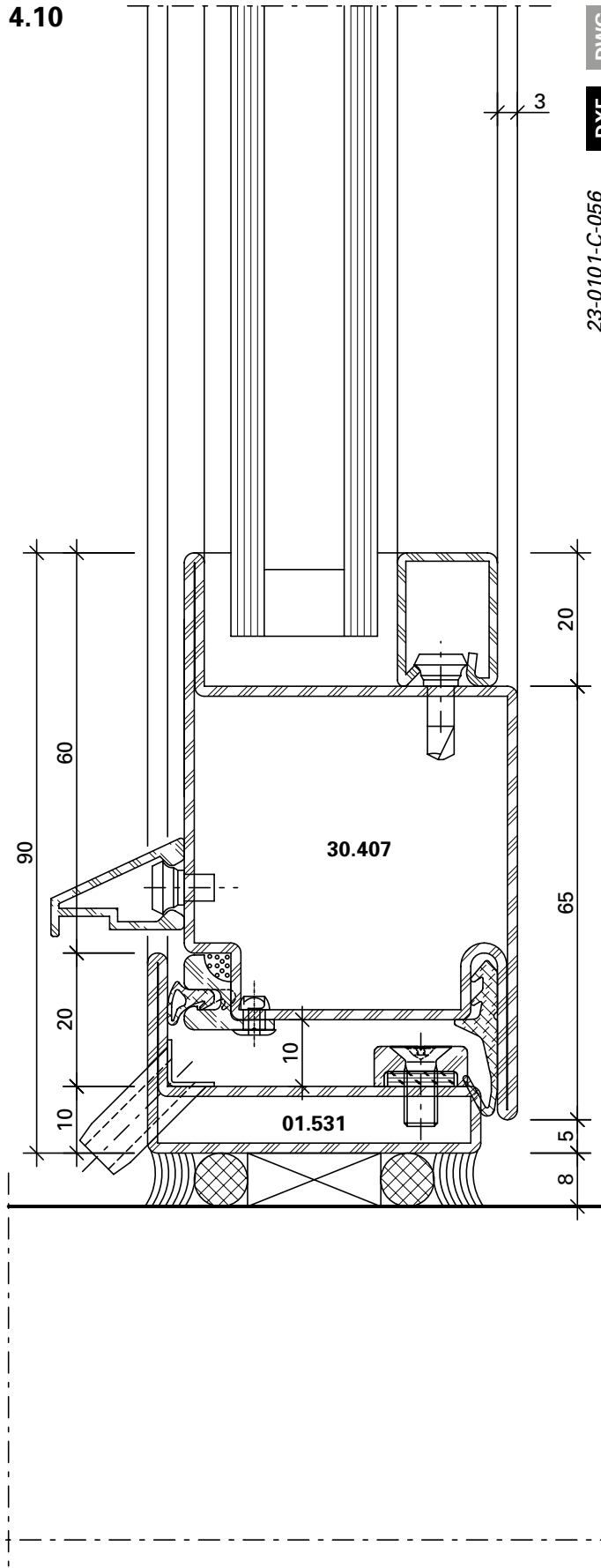

4.11

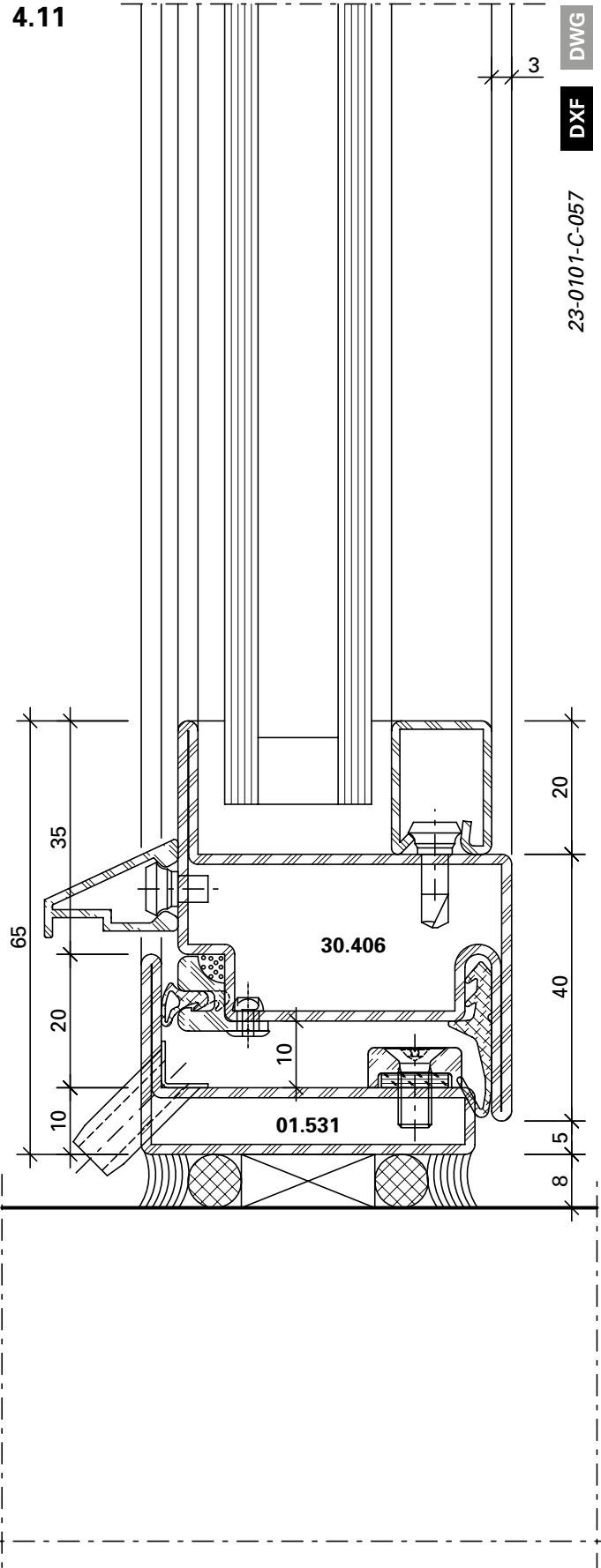

Anwendungsbeispiele
Exemples d'application
Examples of applications
(23-0101-S-001)

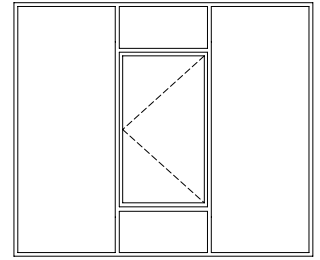
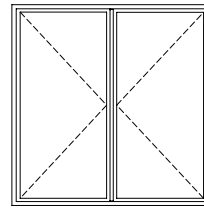
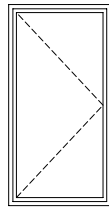

Anwendungsbeispiele
Exemples d'application
Examples of applications
(23-0101-S-002)

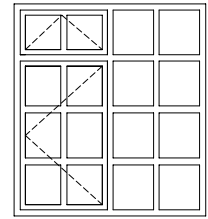
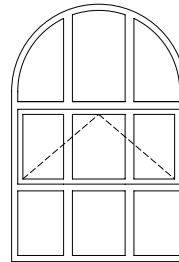
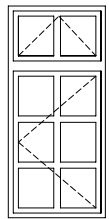

Anwendungsbeispiele
Exemples d'application
Examples of applications
(23-0101-S-003)

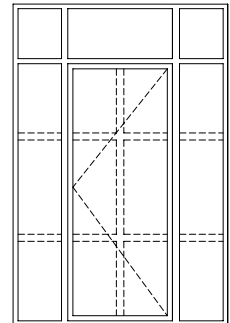
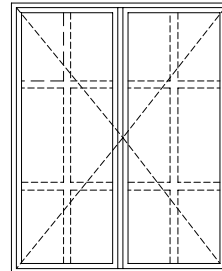
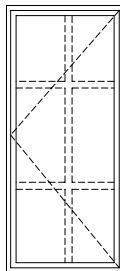

Anwendungsbeispiele
Exemples d'application
Examples of applications
(23-0101-S-004)

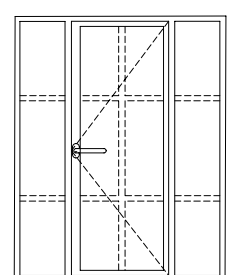
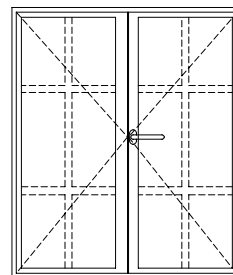
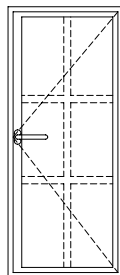

Anwendungsbeispiele
Exemples d'application
Examples of applications
(46-0101-S-005)

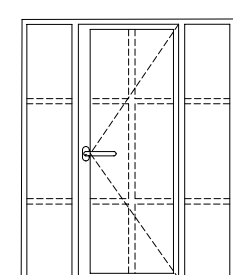
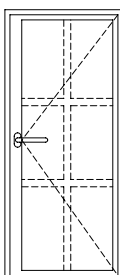

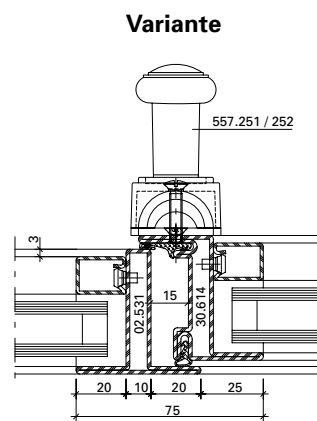
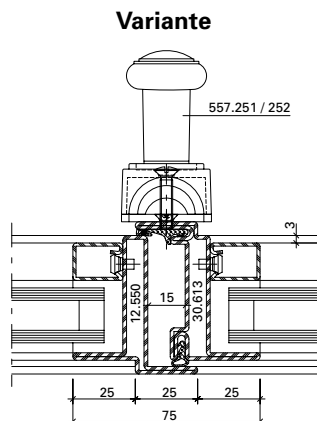
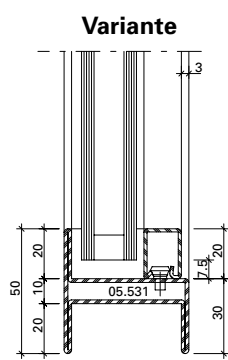
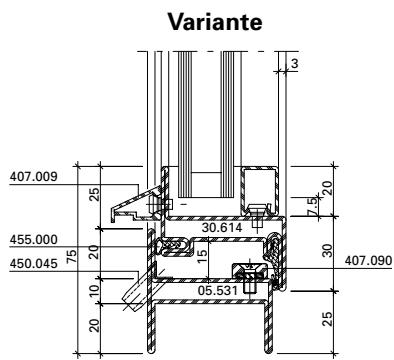
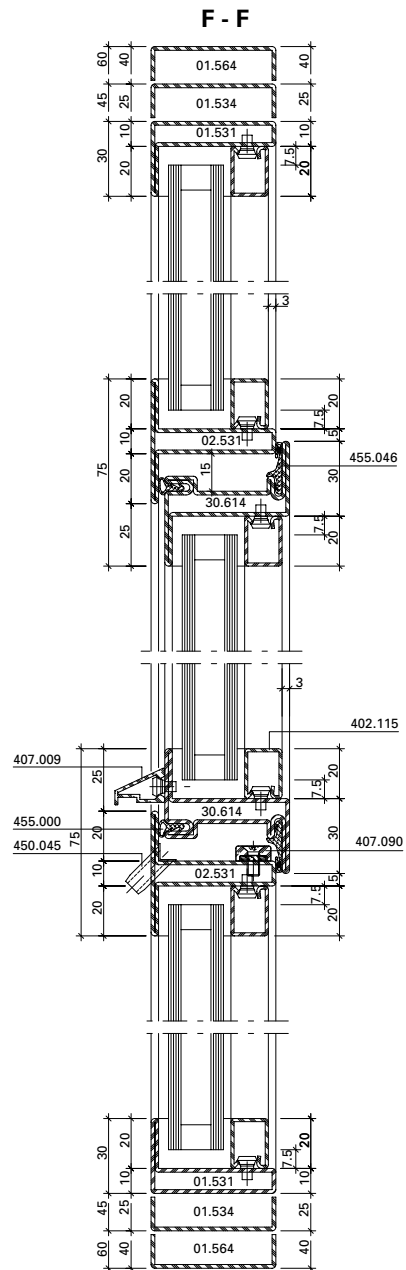
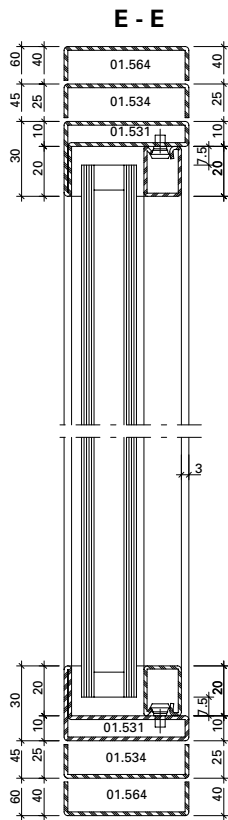
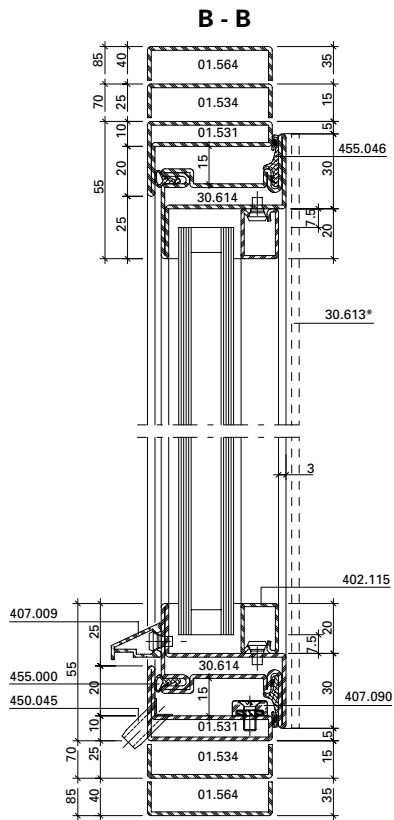

- * Situation Stulpfenster
- * Situation fenêtre à deux vantaux
- * Situation double vent window

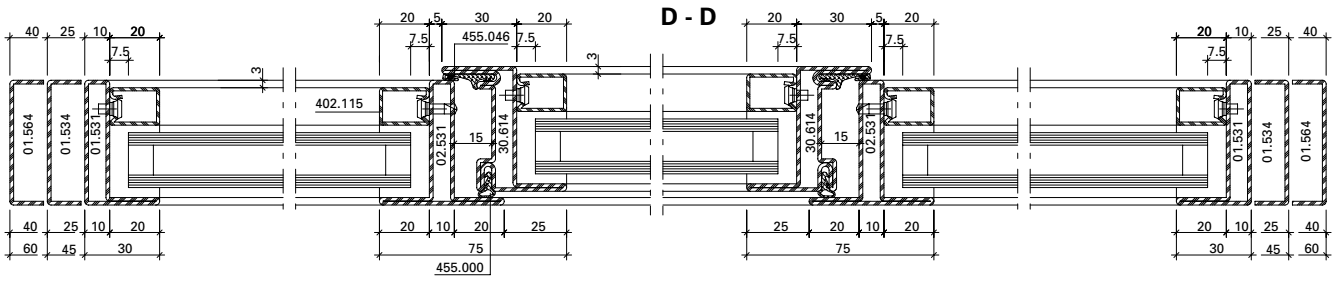

Variante

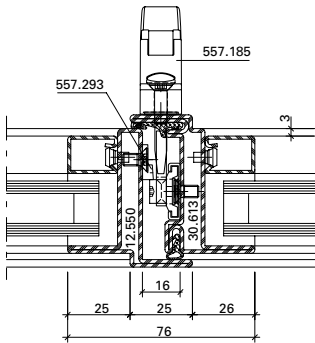

C - C

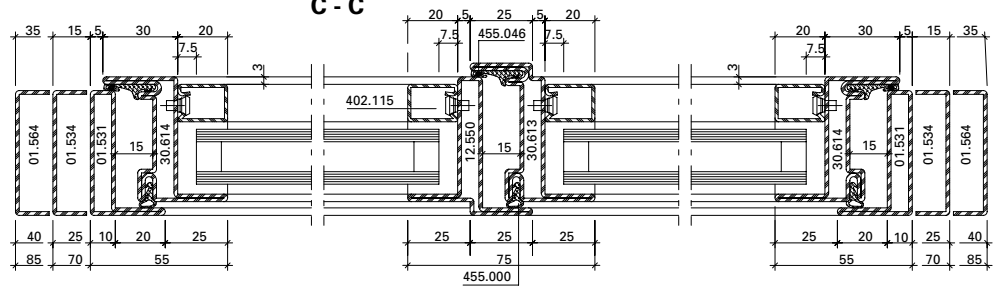

Variante

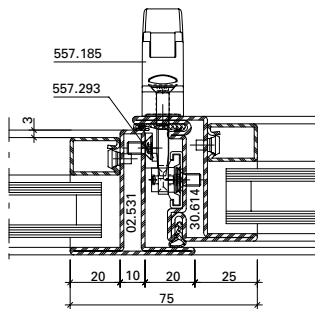

A - A

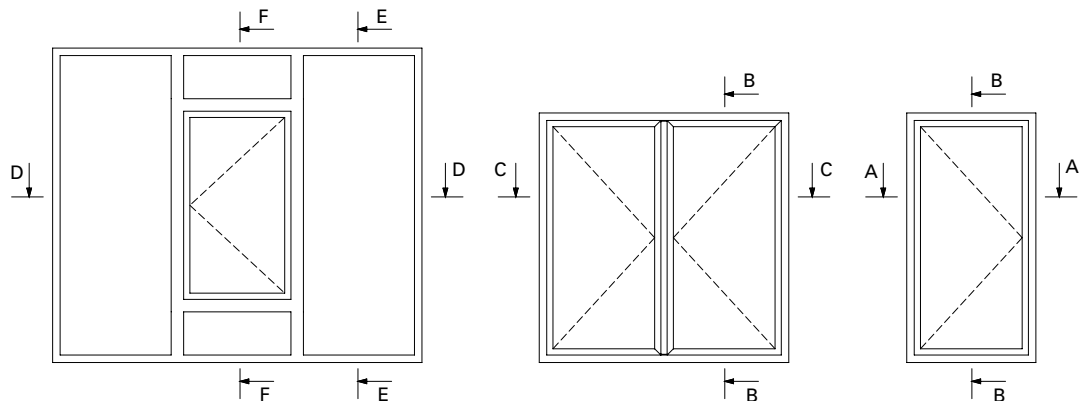
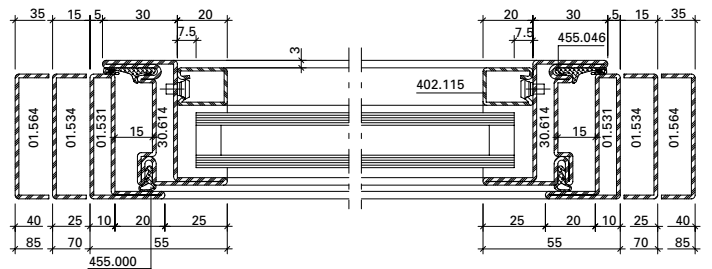

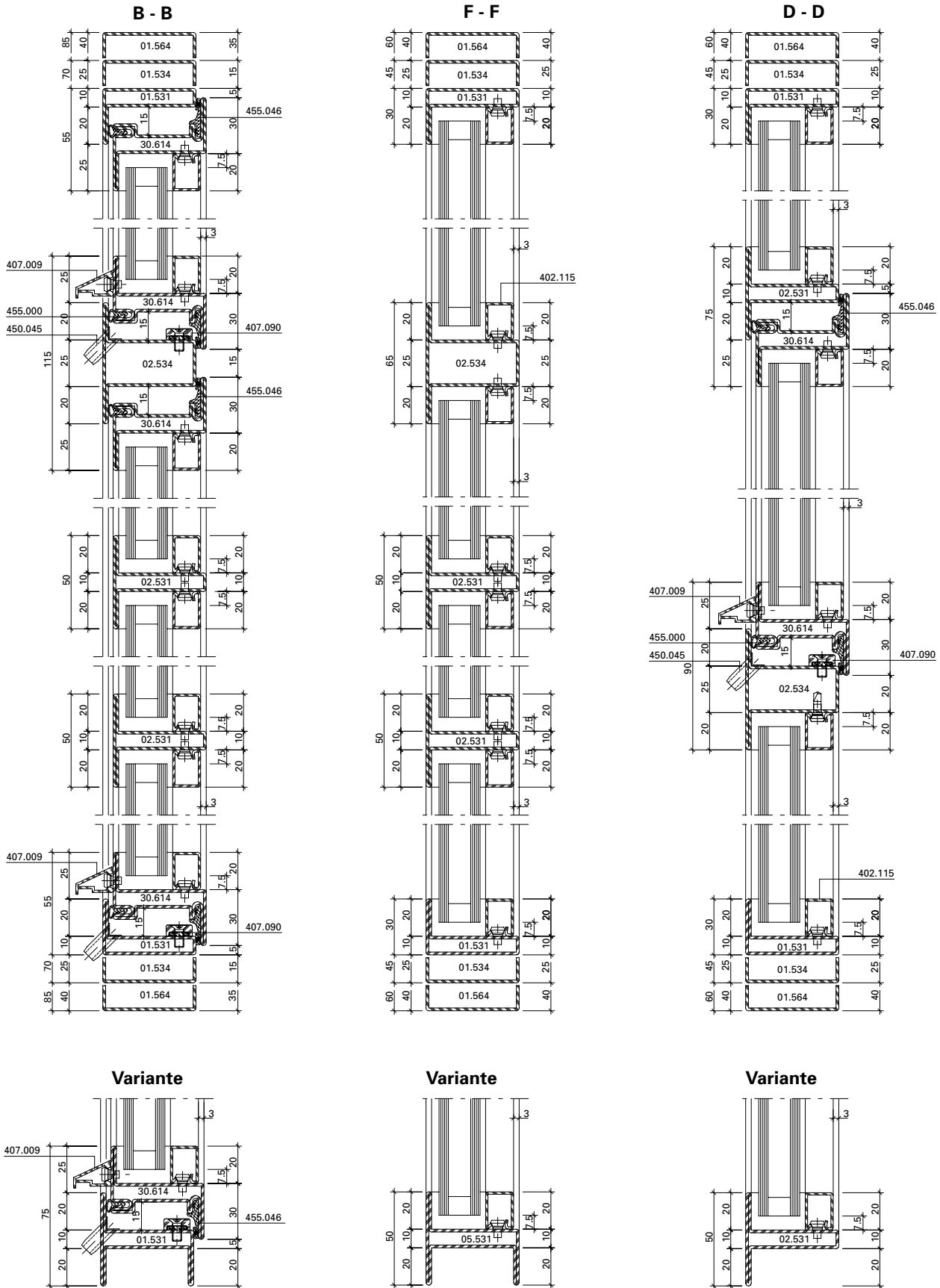

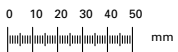
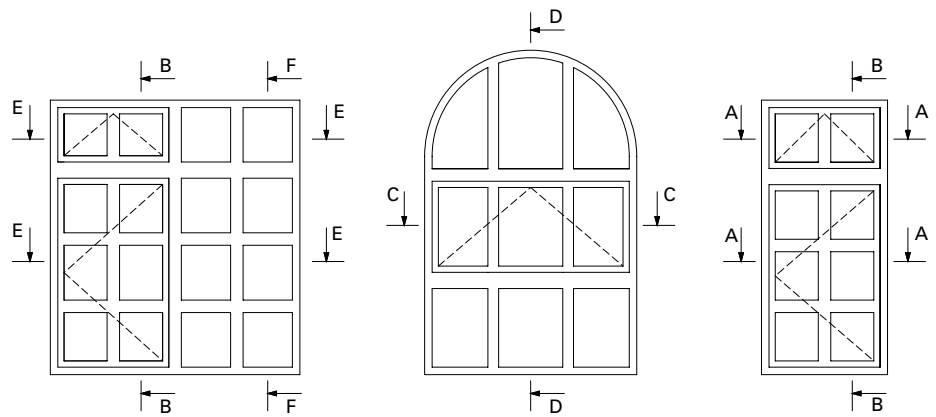
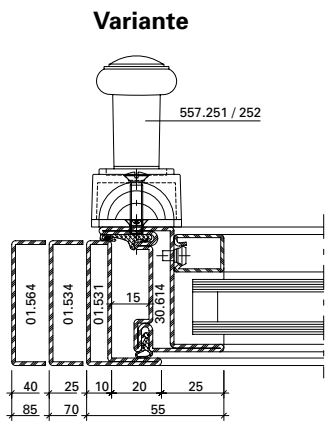
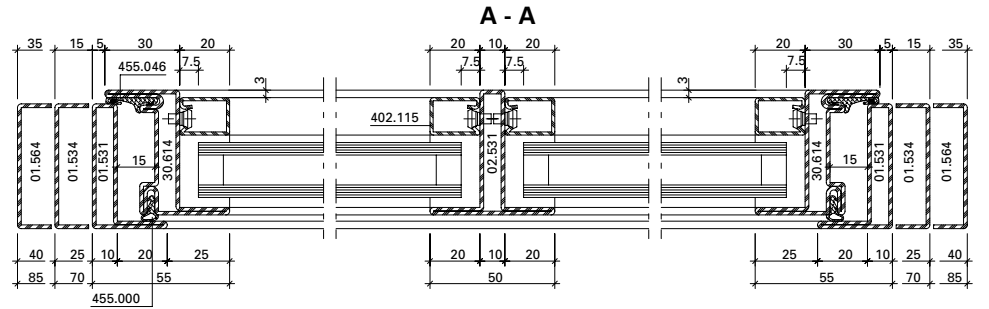
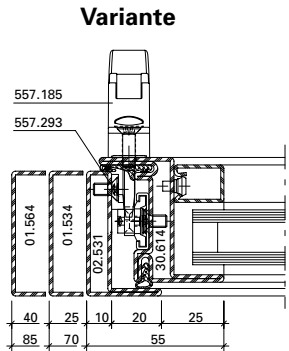
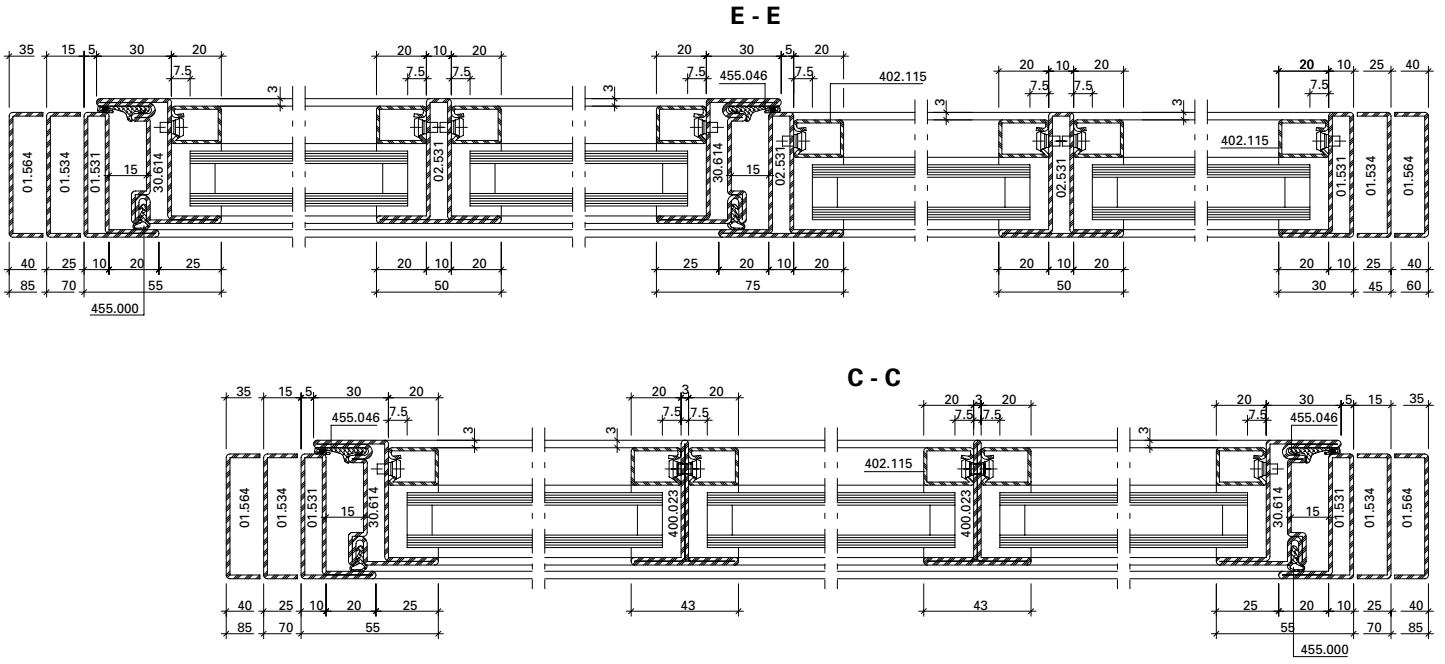

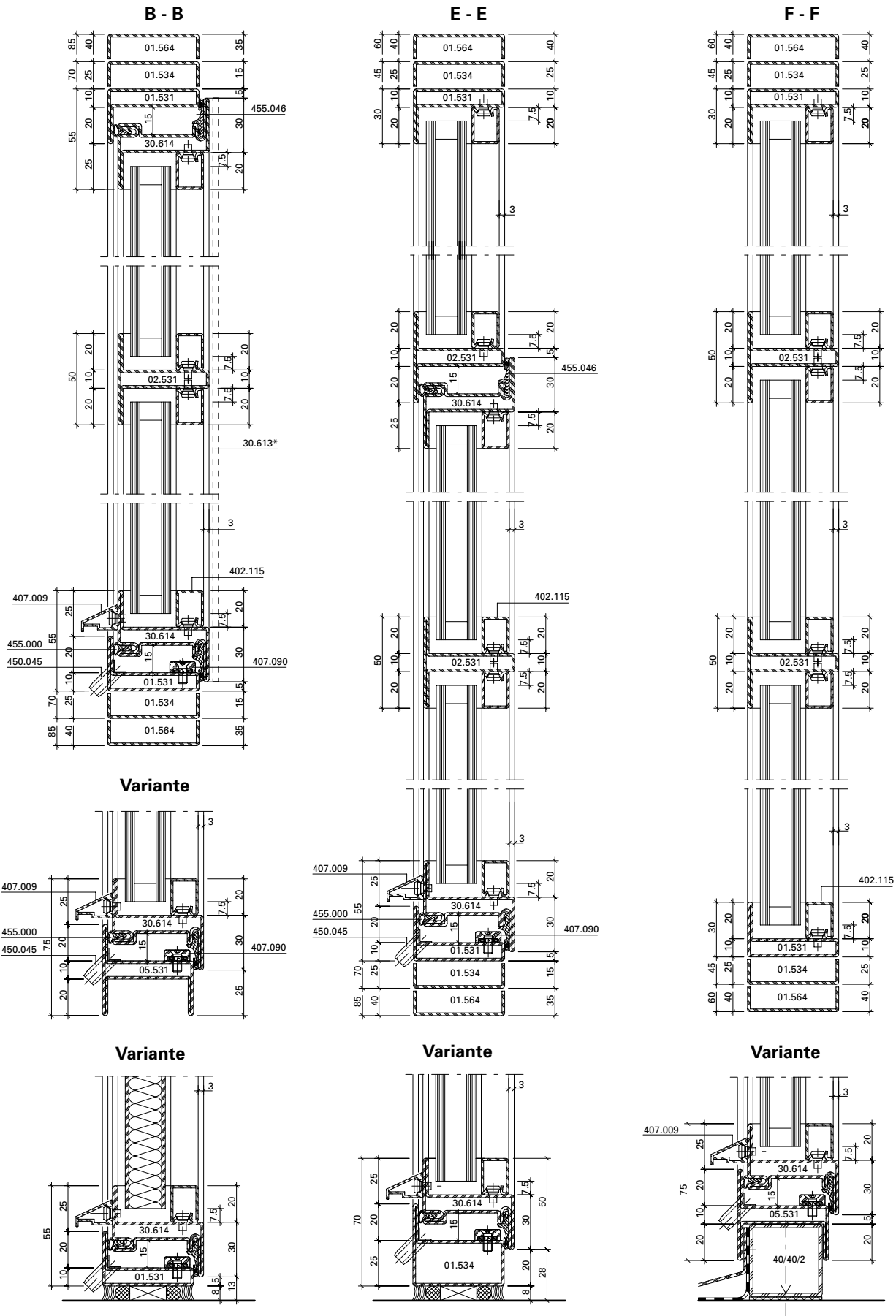

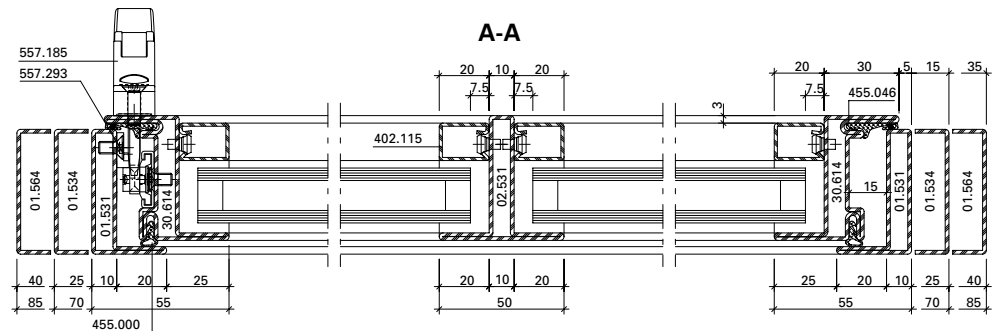
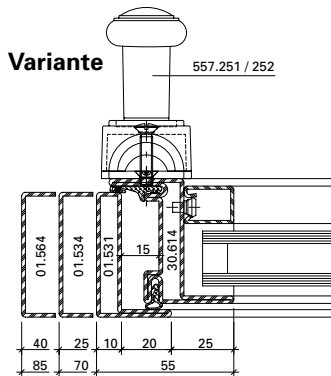
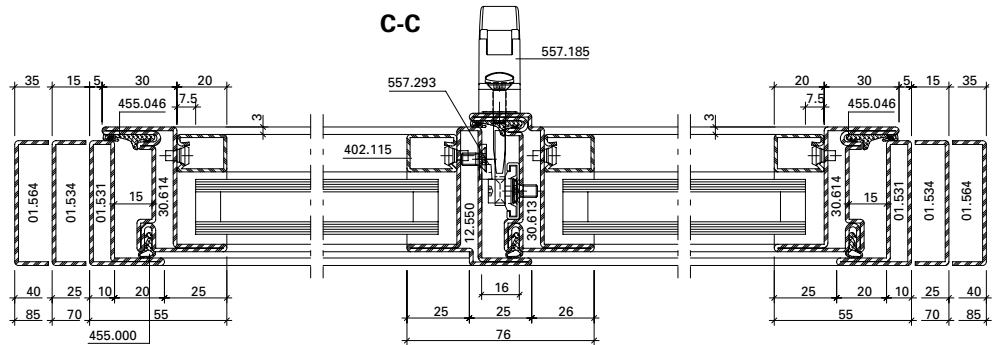
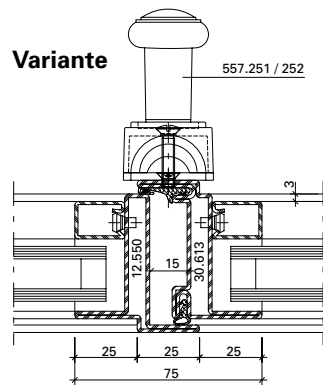
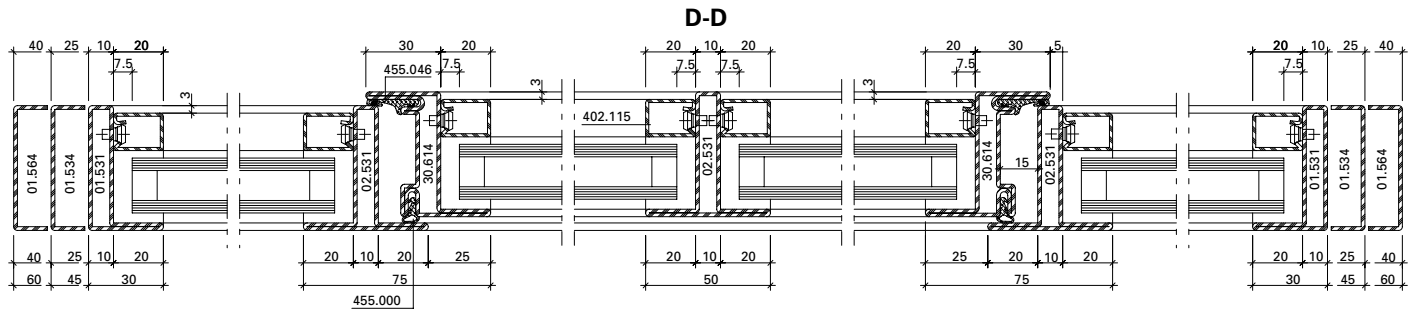

- * Situation Stulpfenster
- * Situation fenêtre à deux vantaux
- * Situation double vent window

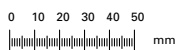
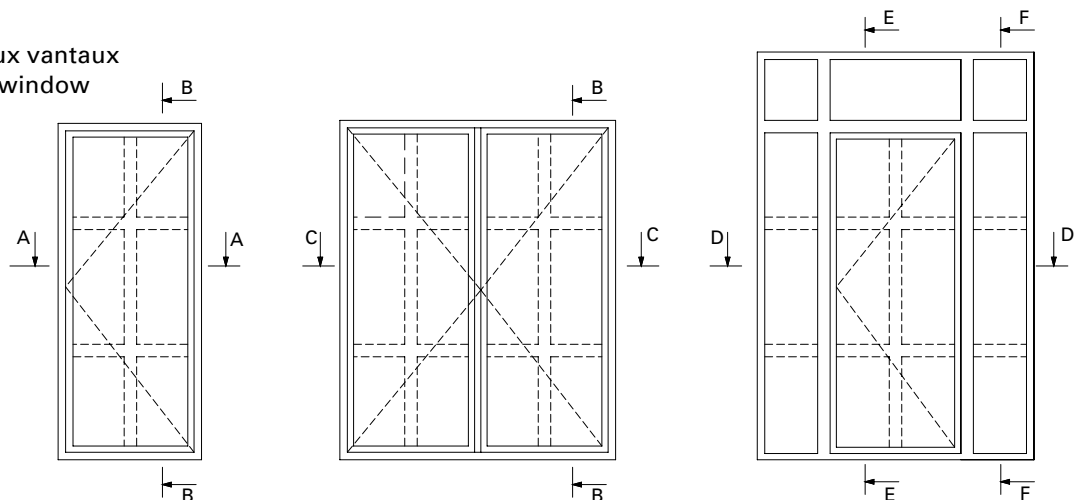

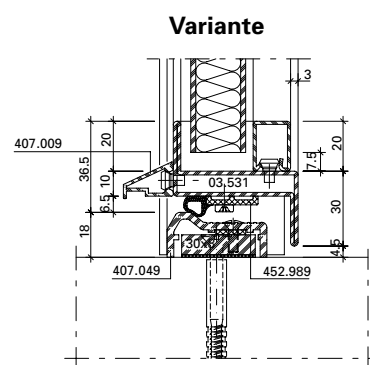
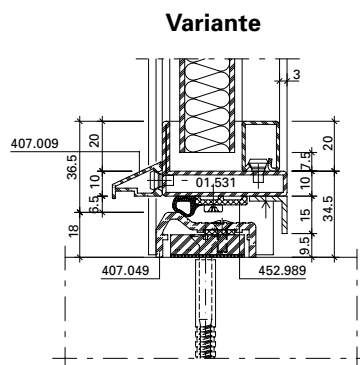
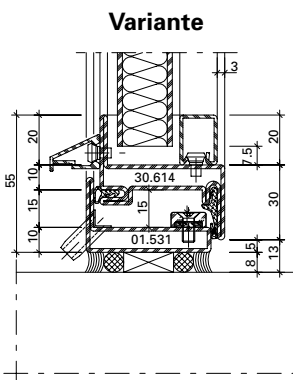
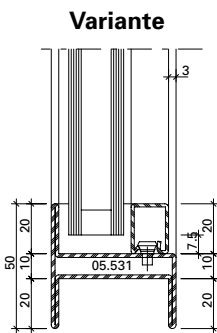
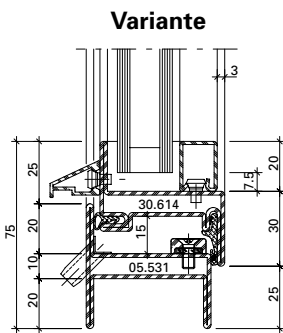
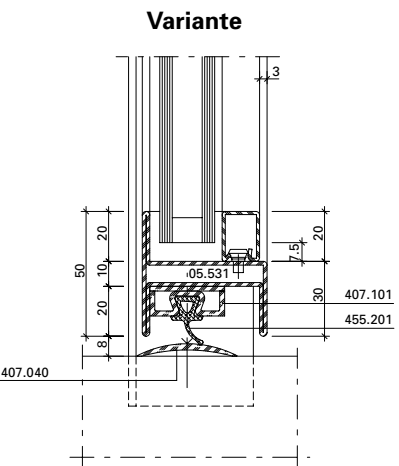
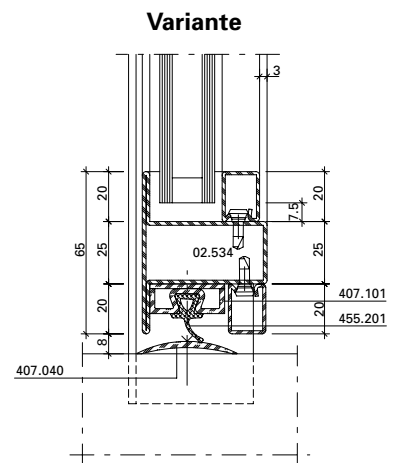
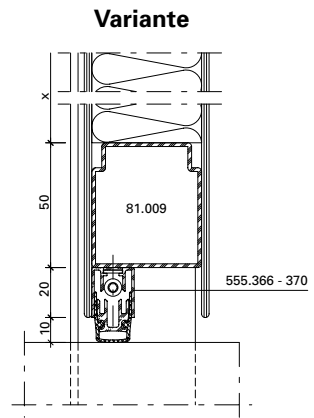
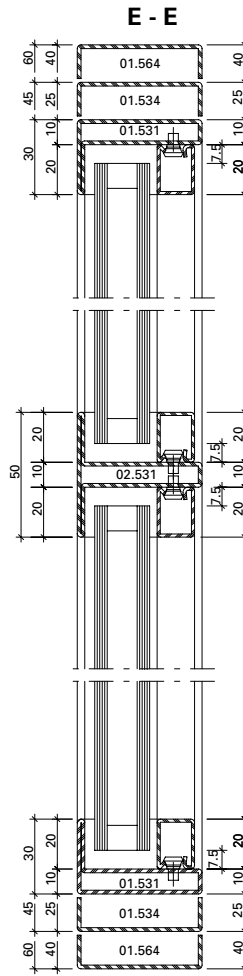
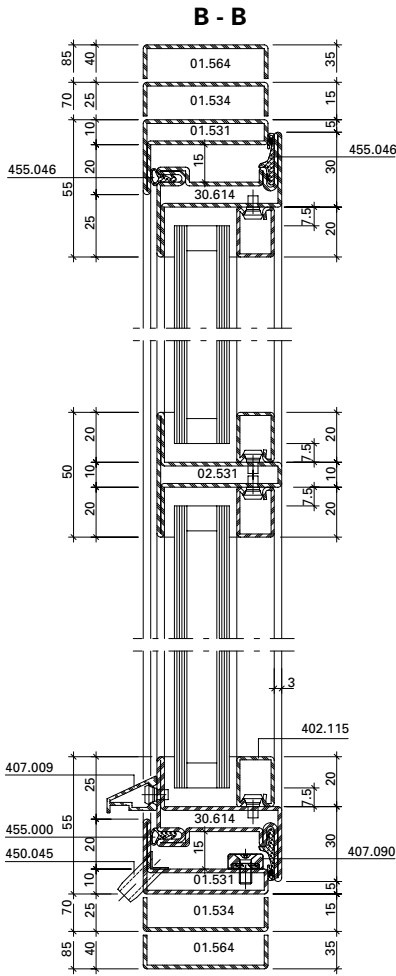

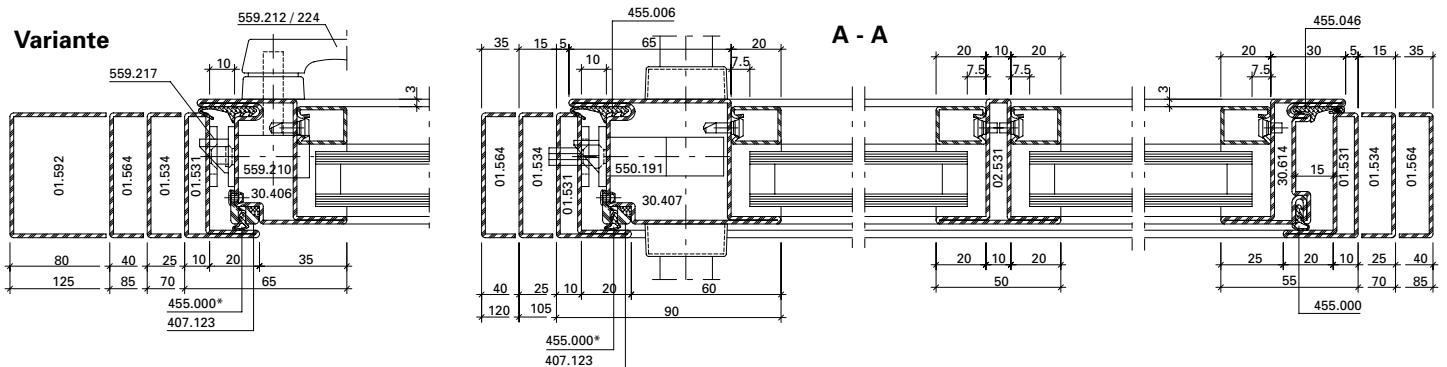
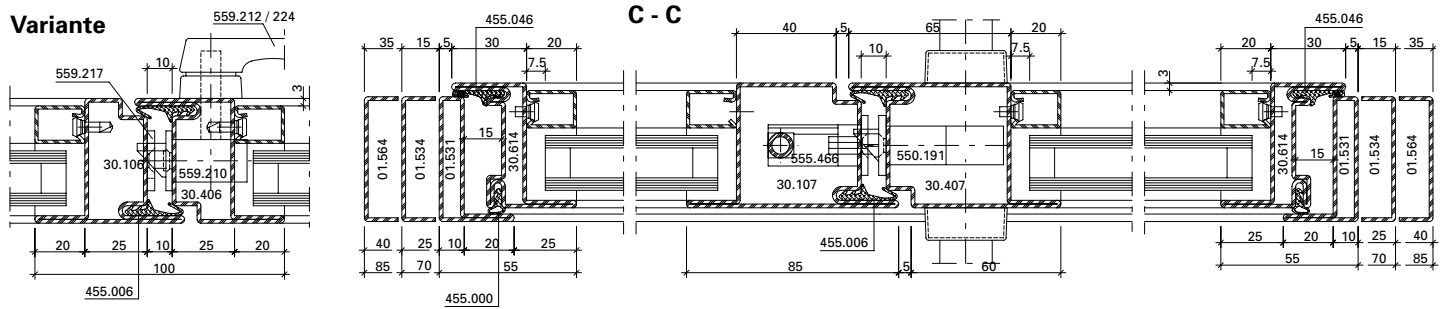
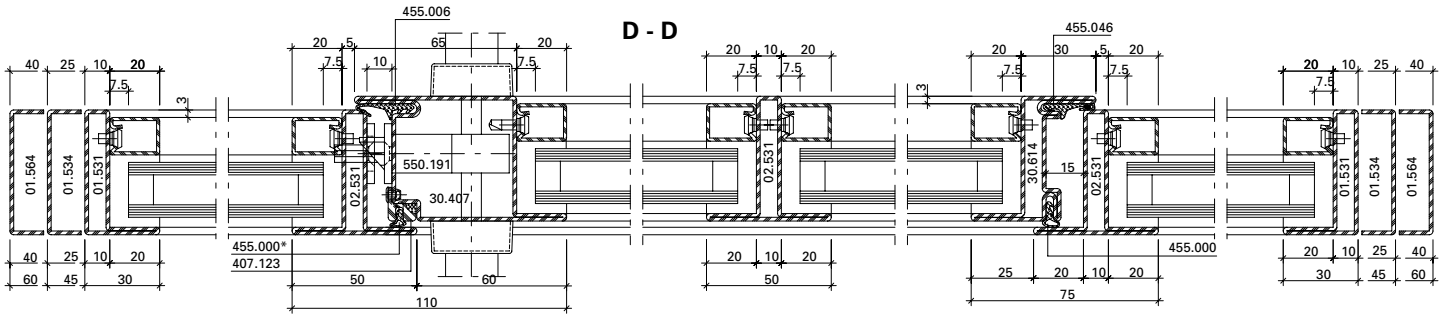

* Dichtung gekürzt
 * Joint raccourcie
 * Weatherstrip shortened

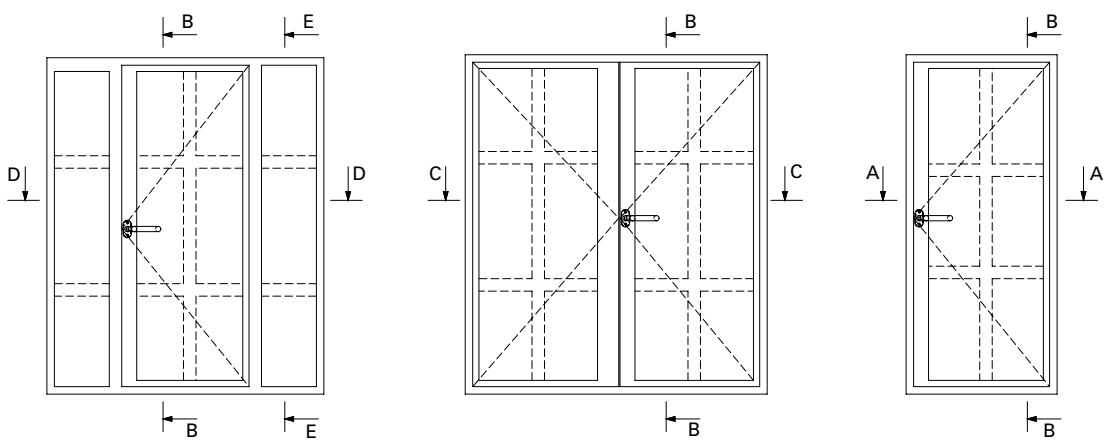

Sonderkonstruktion
 (nach Produktnorm EN 14351
 nicht geprüft)

Construction spéciale
 (non contrôlé selon la norme
 produit EN 14351)

Special construction
 (not tested in accordance with
 the EN 14351 product standard)

Nur für Markt Frankreich

Seulement pour marché France

Only for the French market

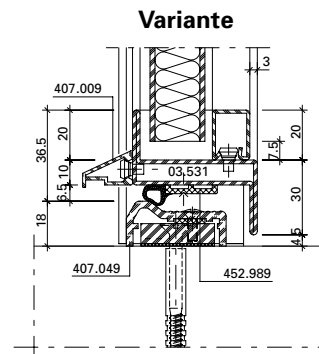
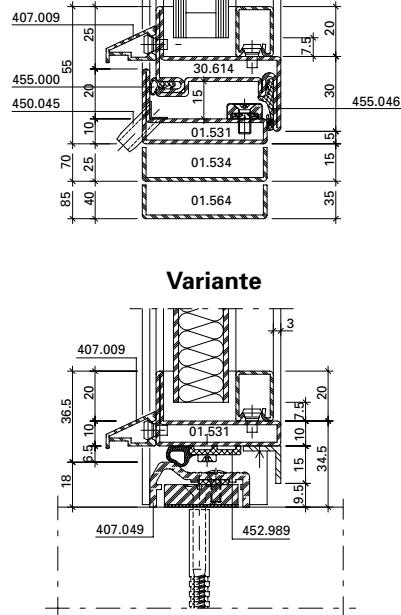
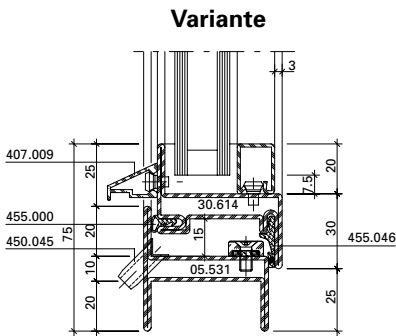
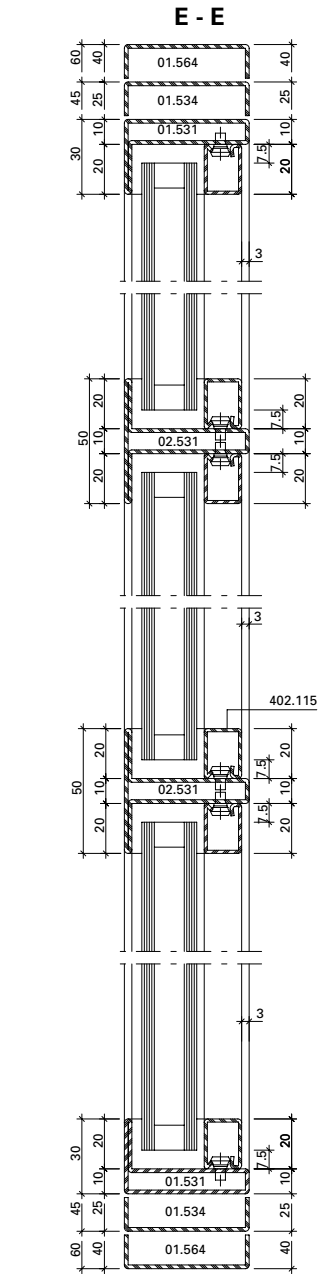
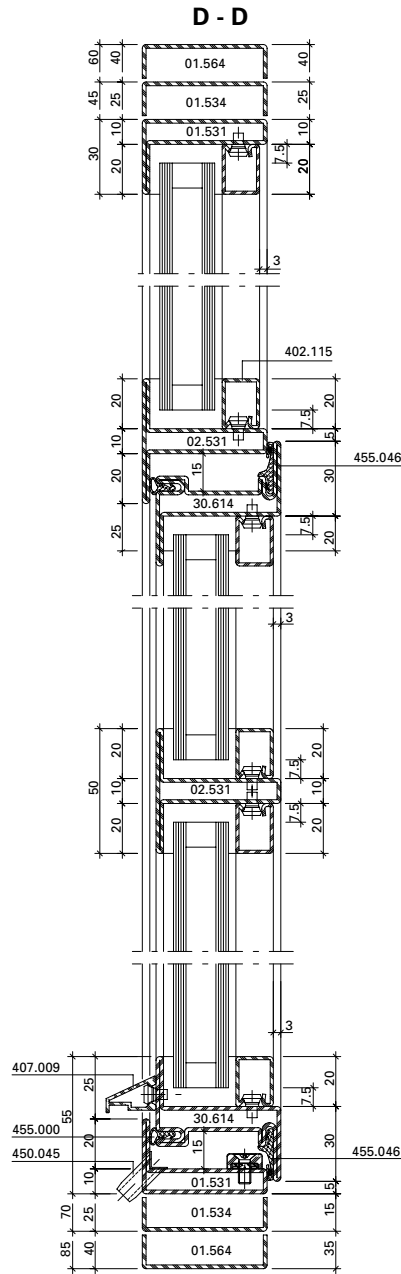
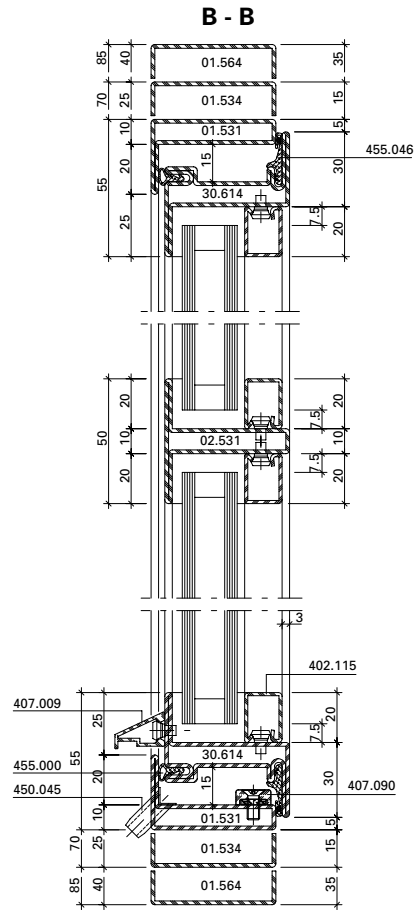

Nur für Markt Frankreich

Seulement pour marché France

Only for the French market

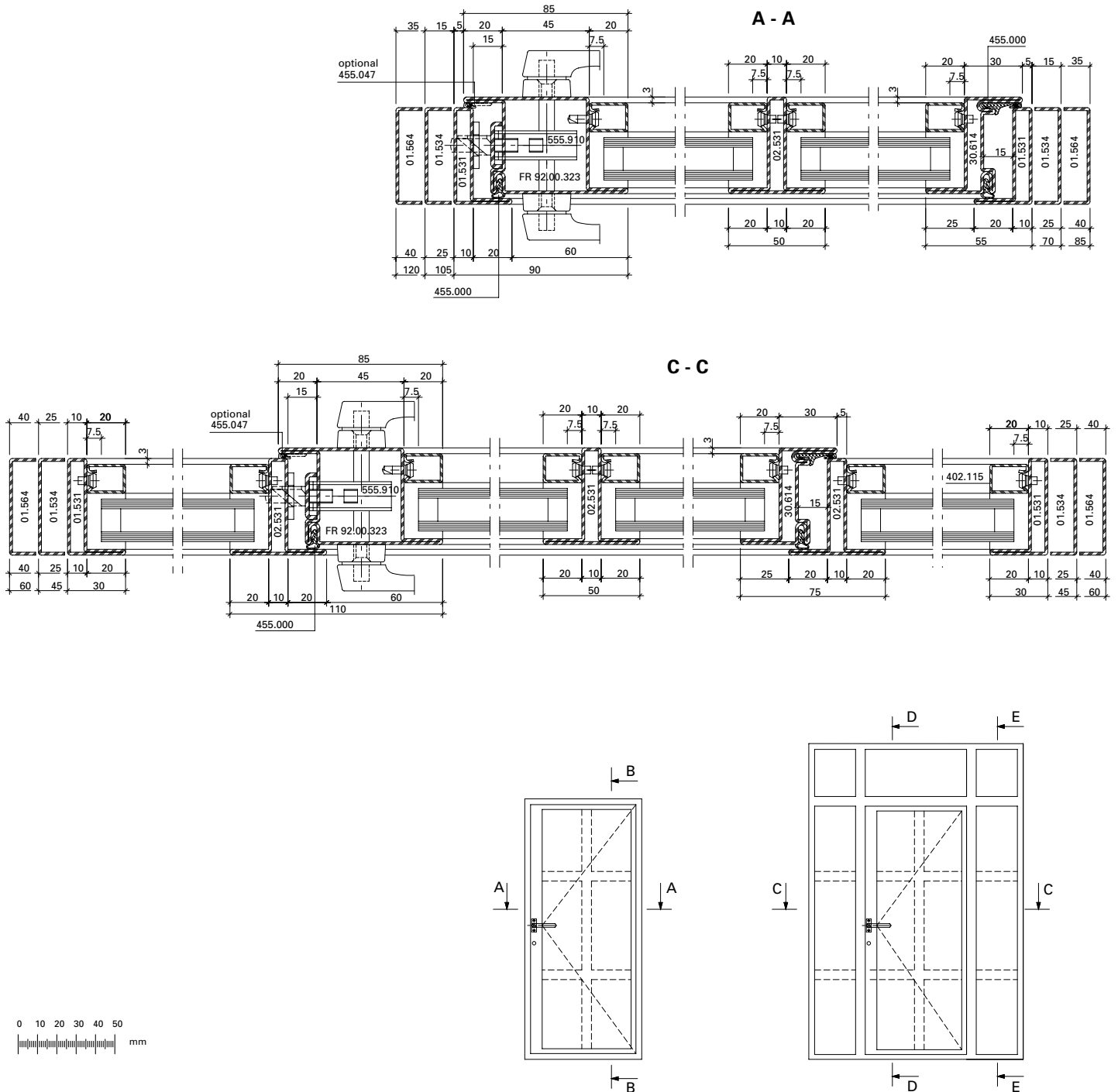

Sonderkonstruktion
 (nach Produktnorm EN 14351
 nicht geprüft)

Construction spéciale
 (non contrôlé selon la norme
 produit EN 14351)

Special construction
 (not tested in accordance with
 the EN 14351 product standard)

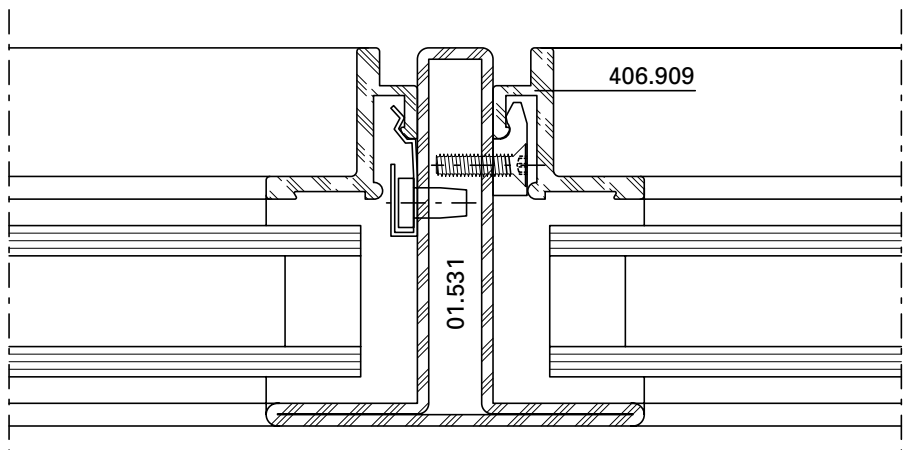
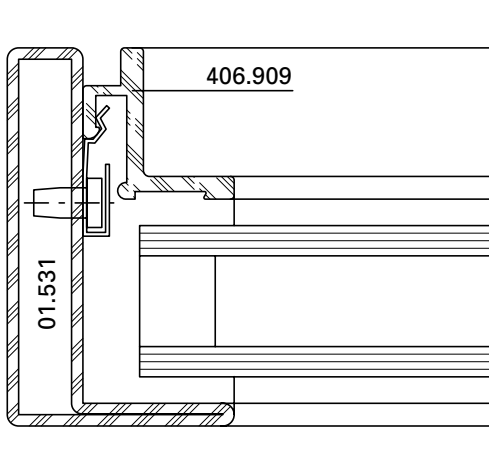
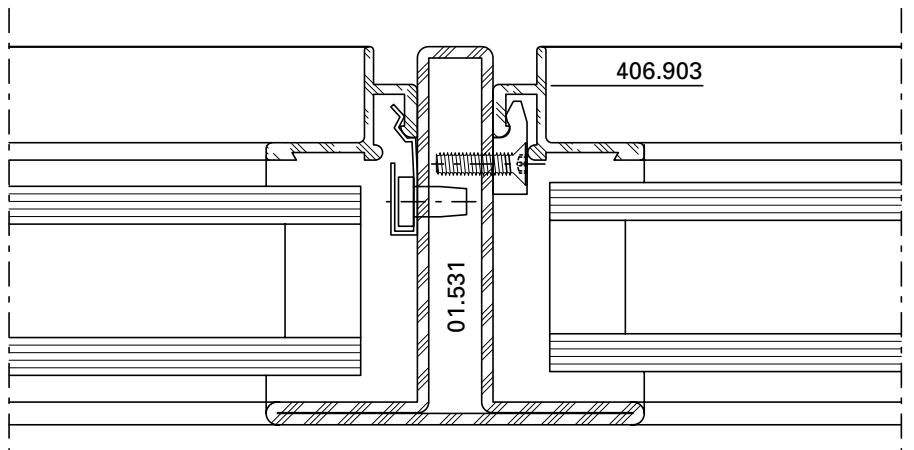
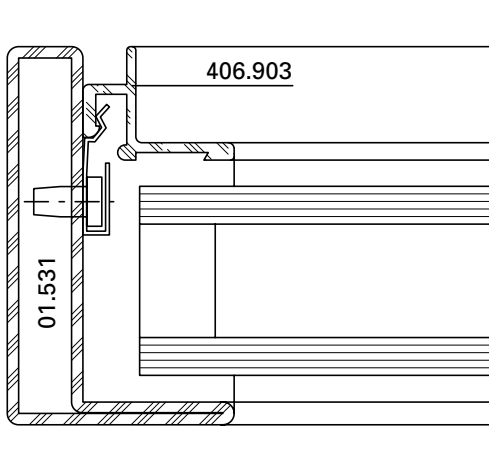
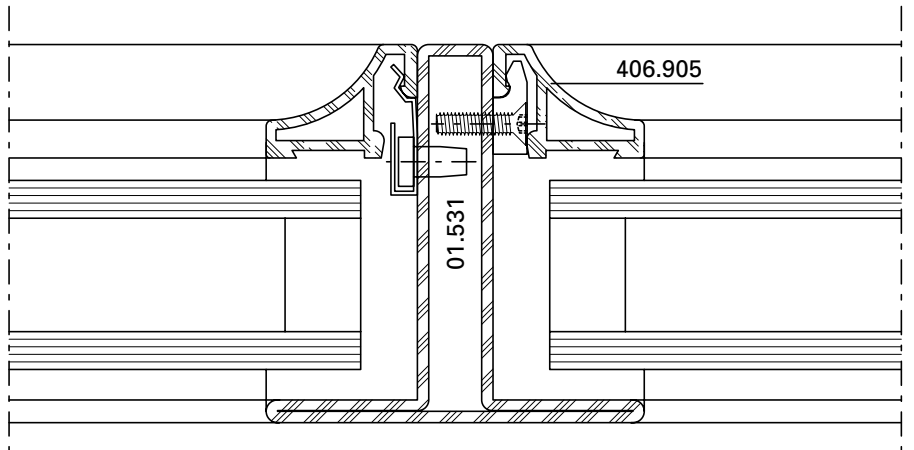
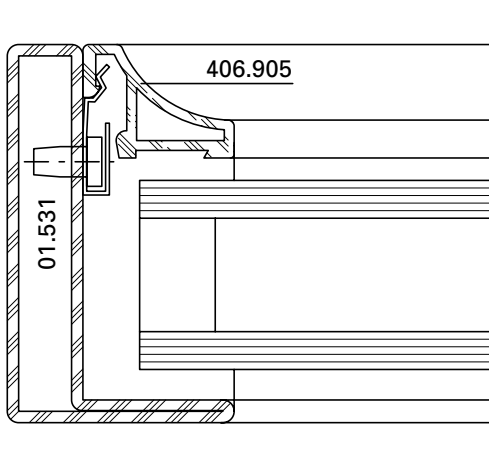

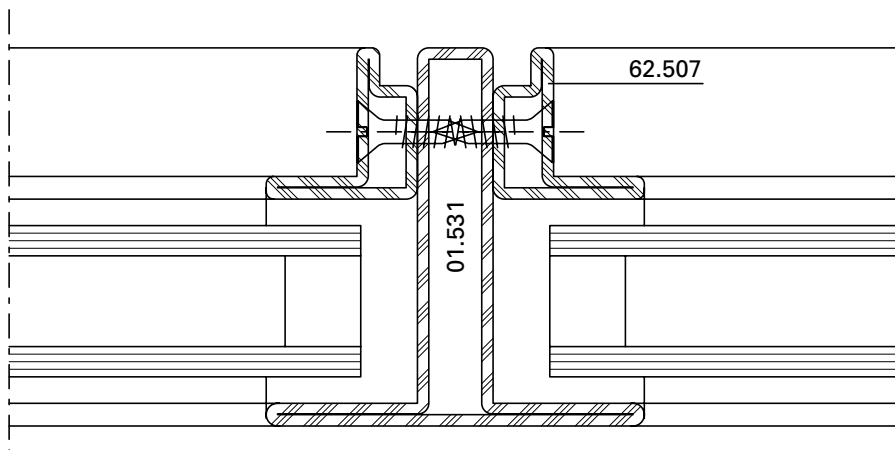
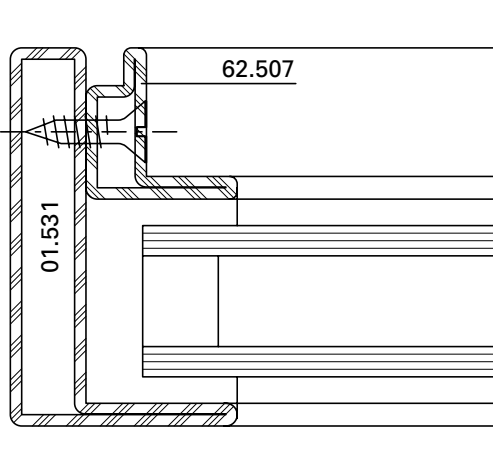
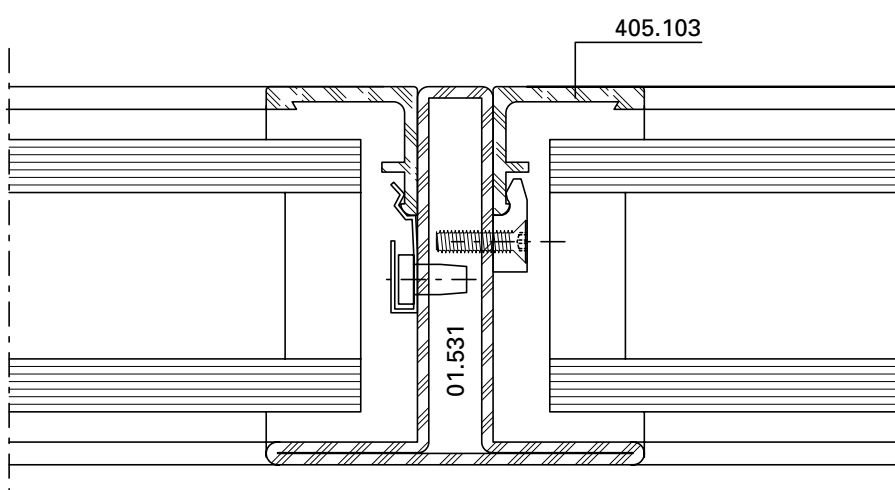
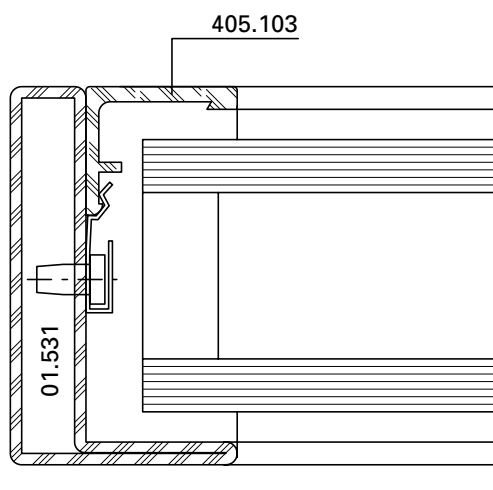
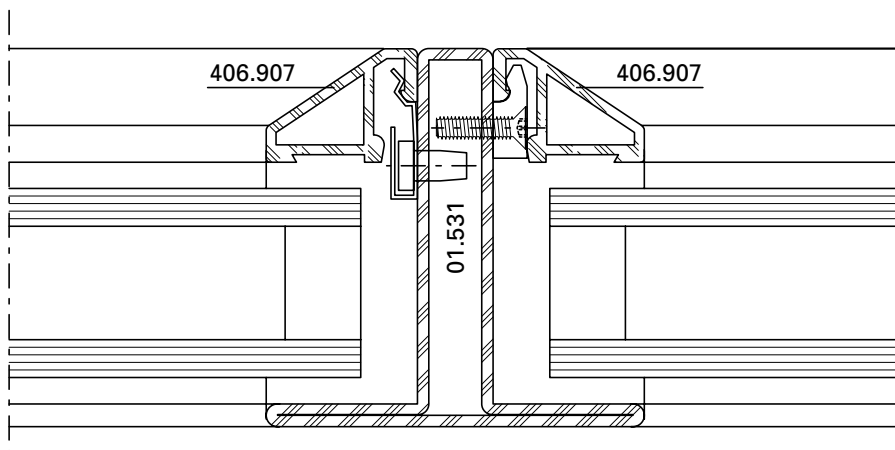
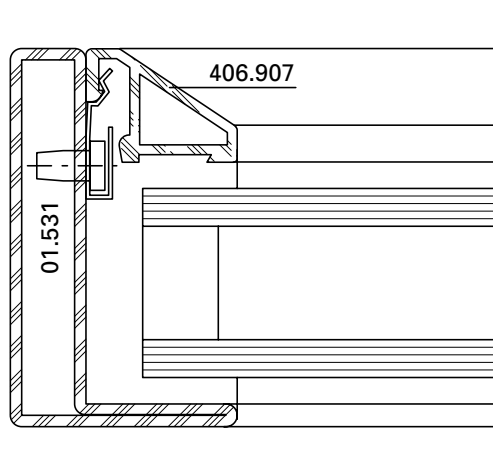

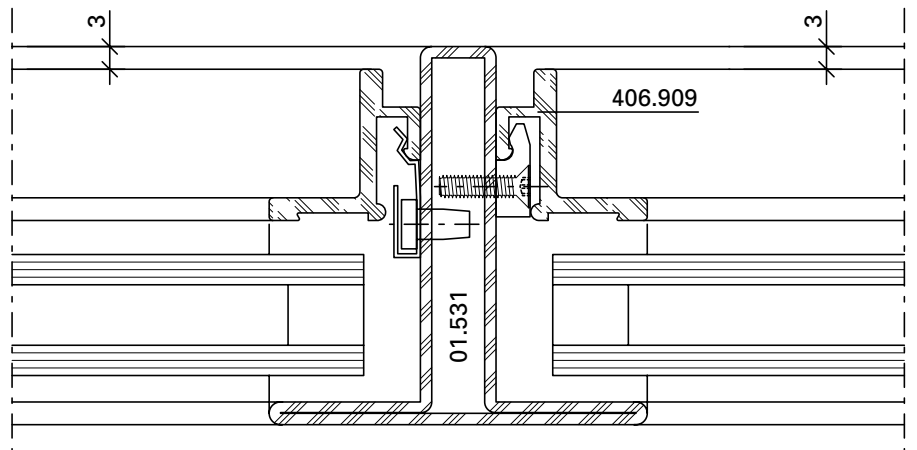
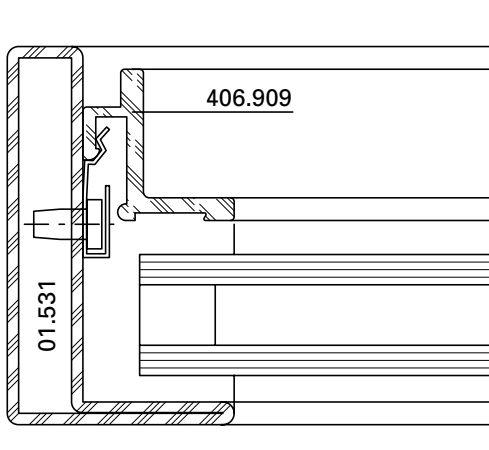
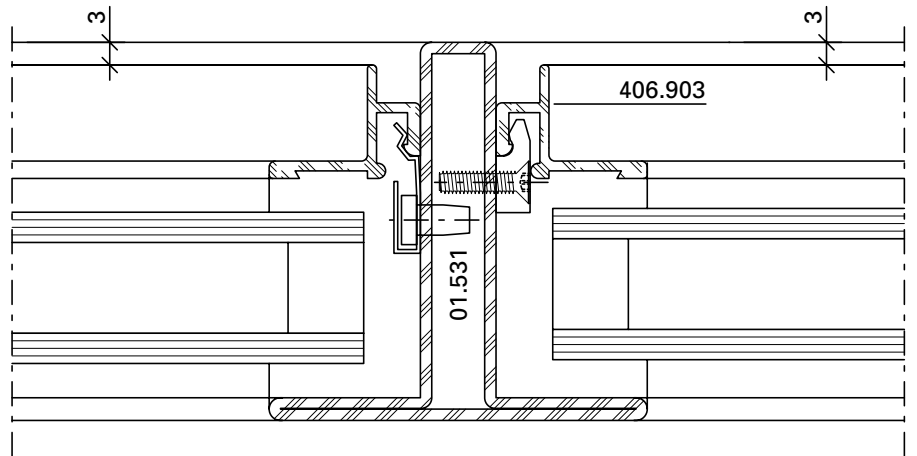
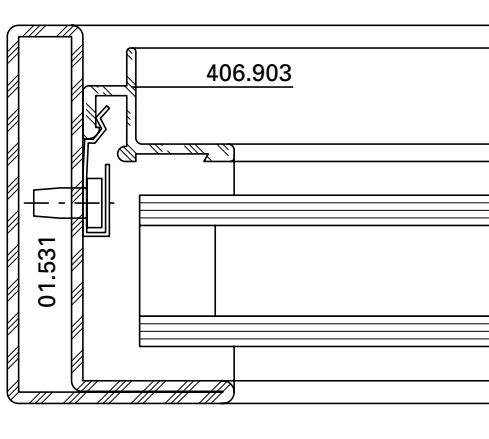
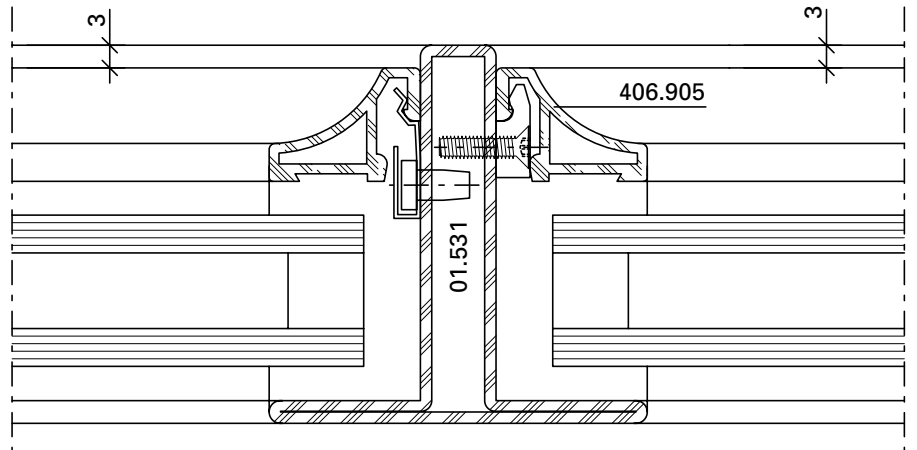
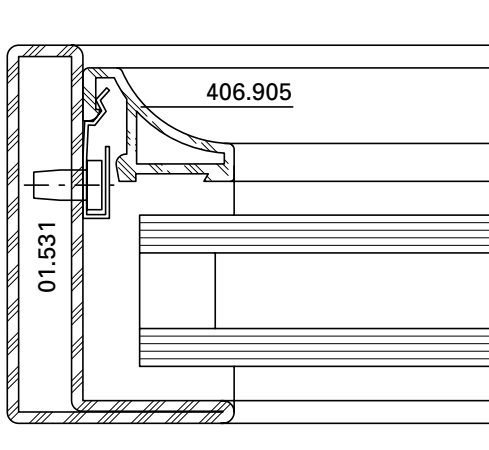

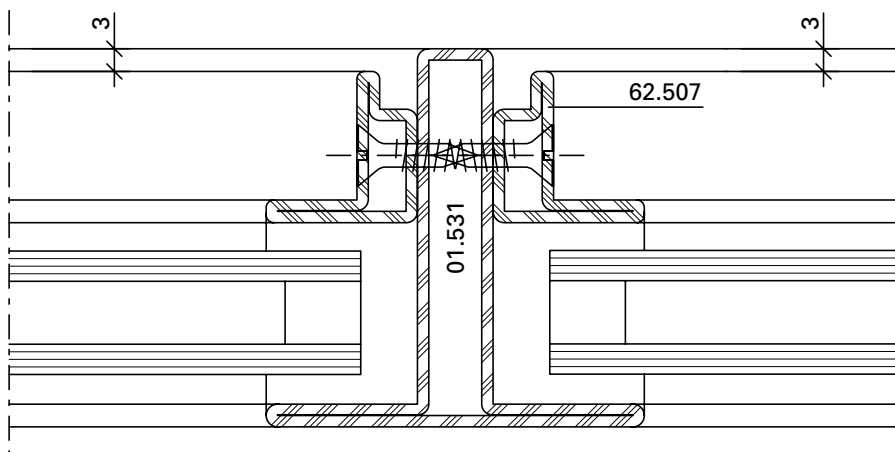
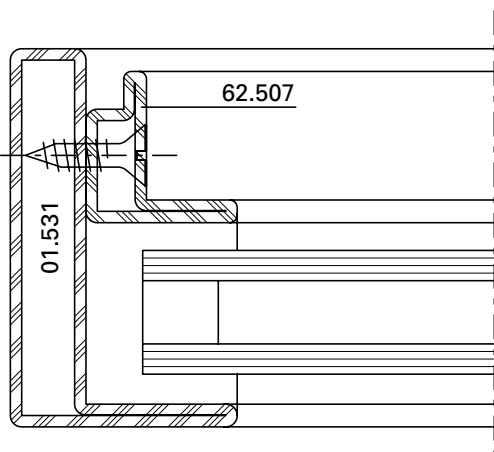
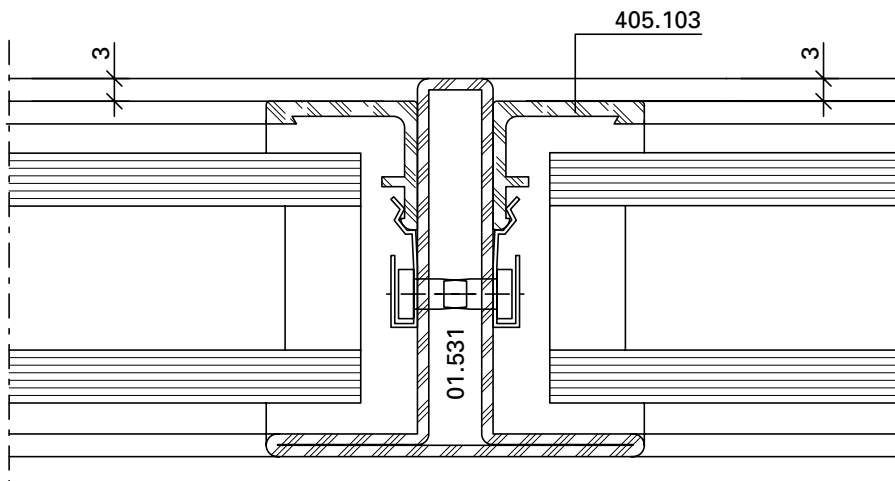
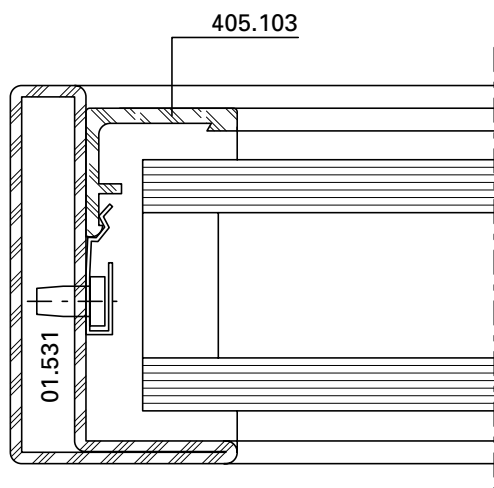
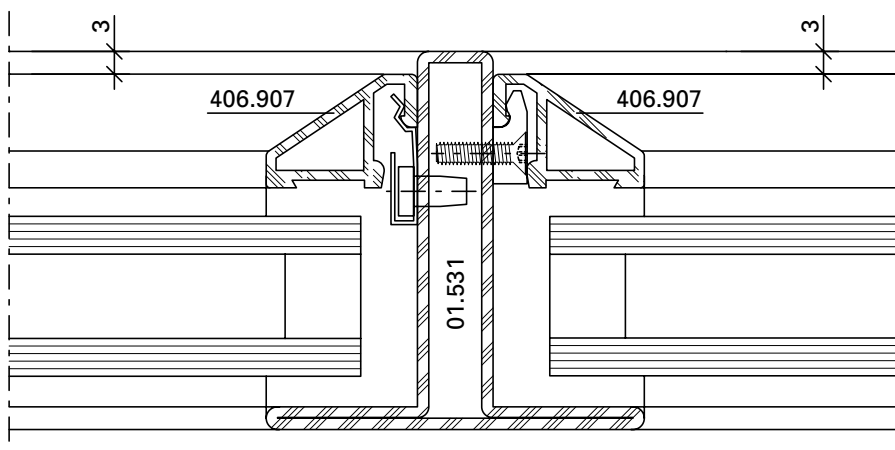
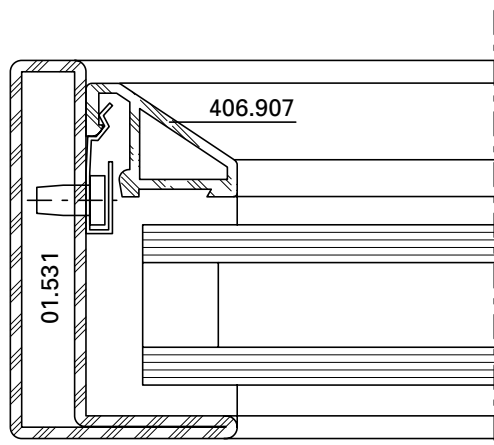

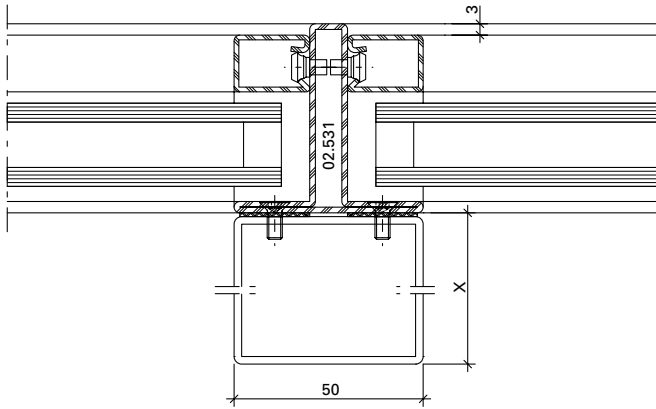

DXF **DWG** 23-0101-K-006

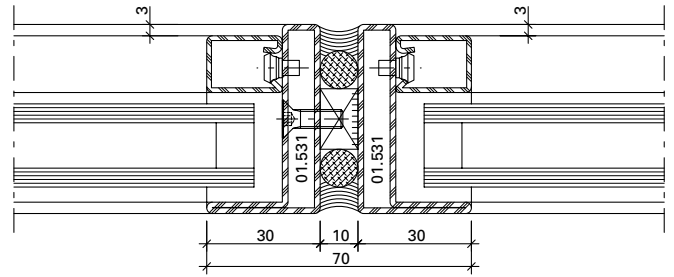

DXF **DWG** 23-0101-K-002

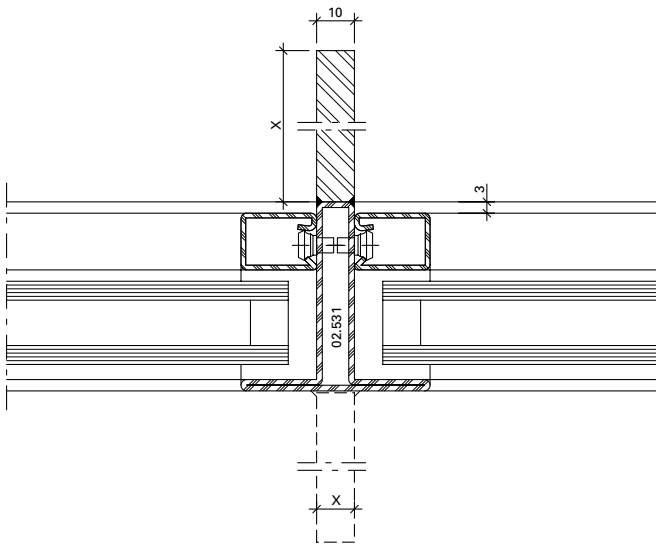

DXF **DWG** 23-0101-K-005

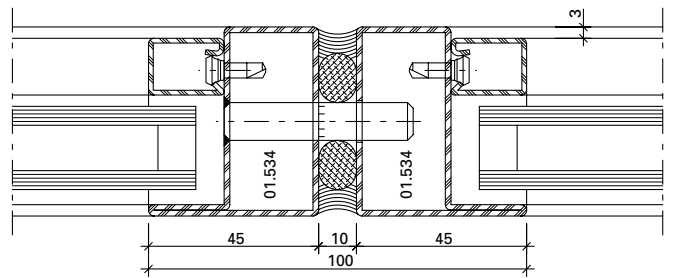

DXF **DWG** 23-0101-K-003

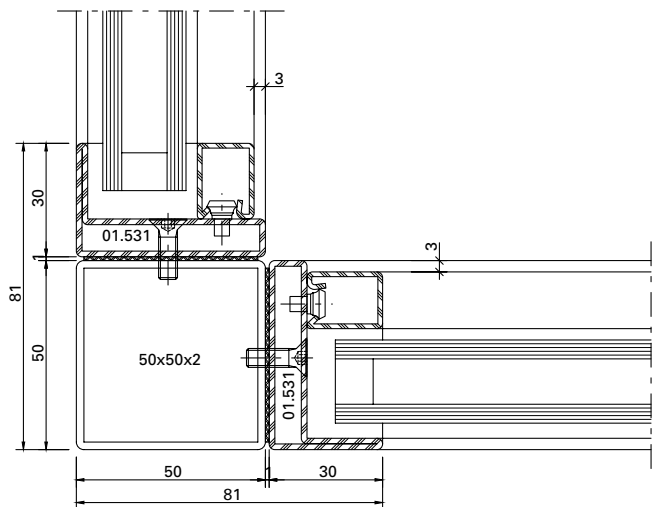

DXF **DWG** 23-0101-K-001

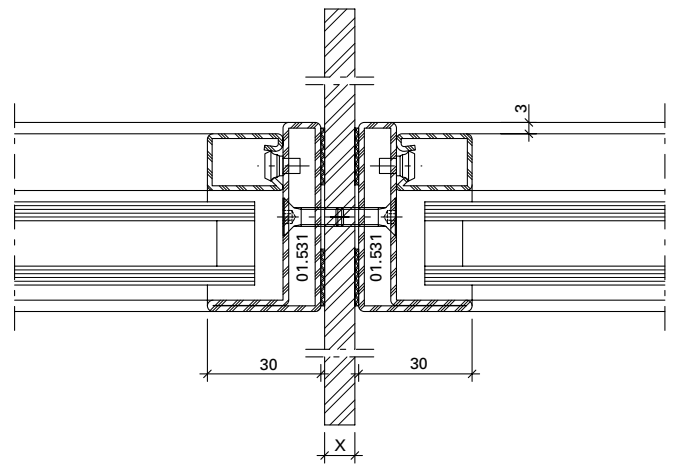

DXF **DWG** 23-0101-K-004

Anschlüsse am Bau im Masstab 1:2
Raccords au mur à l'échelle 1:2
Attachment to structure on scale 1:2

Jansen Art'System
Jansen Art'System
Jansen Art'System

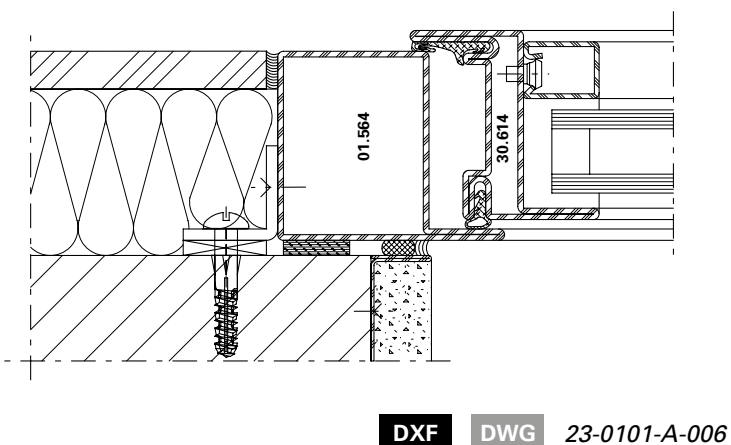
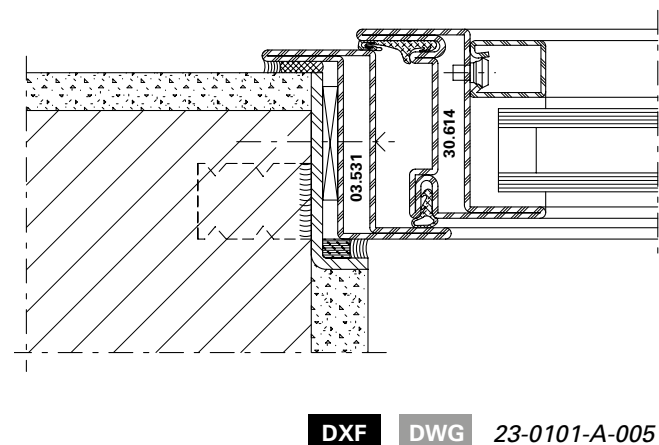
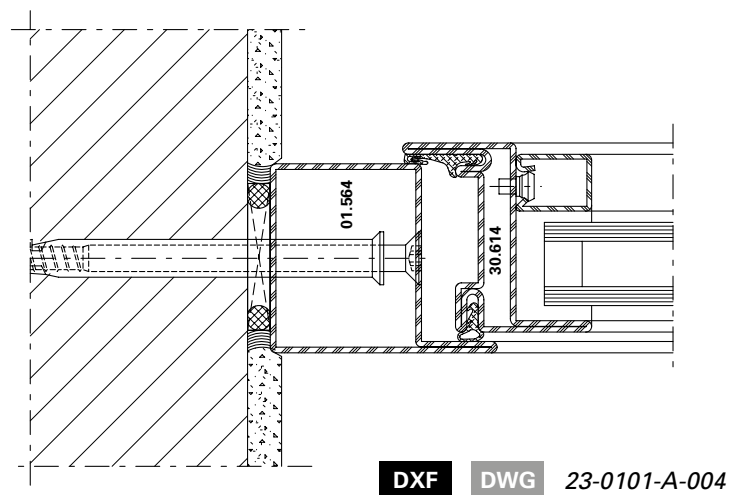
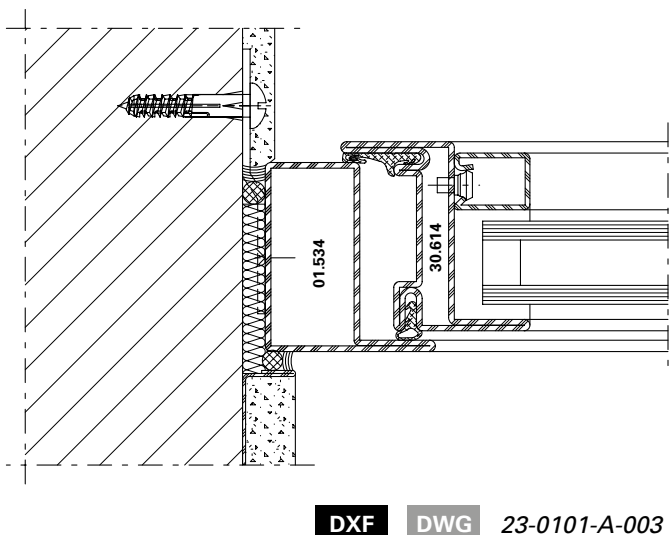
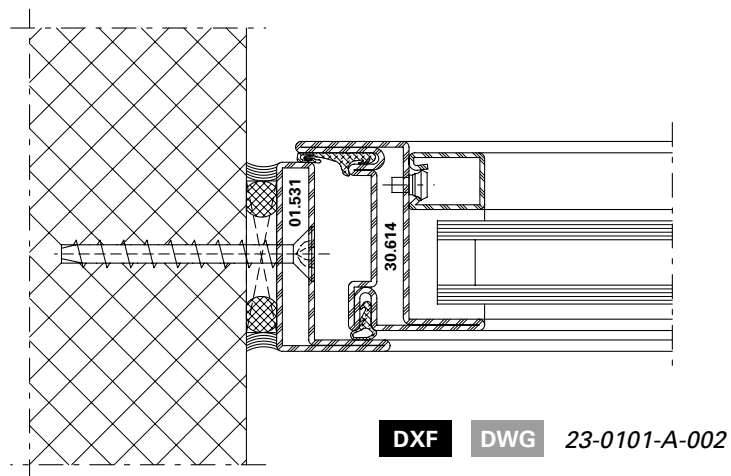
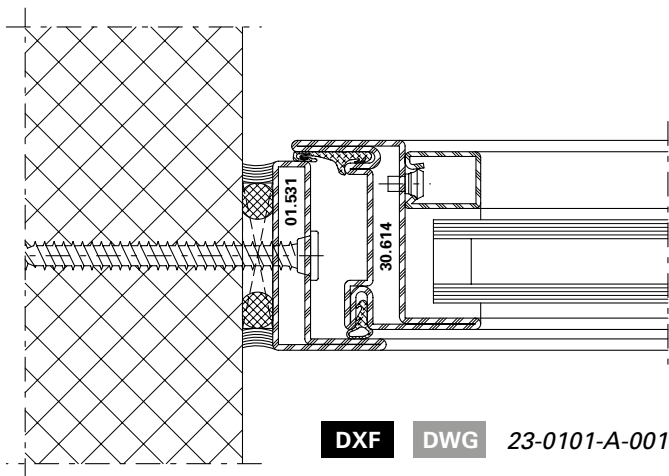

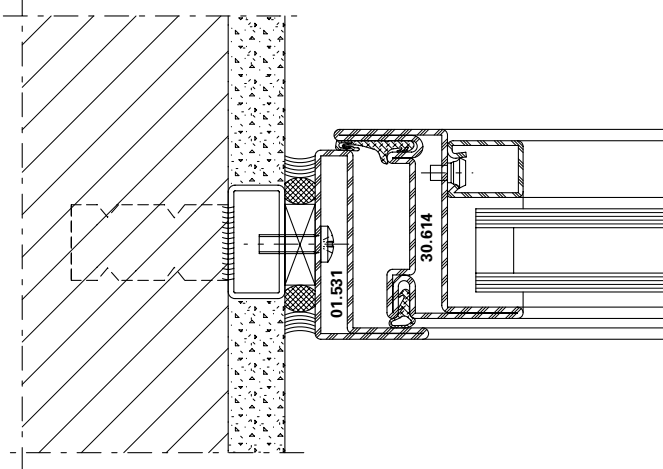

DXF **DWG** 23-0101-A-007

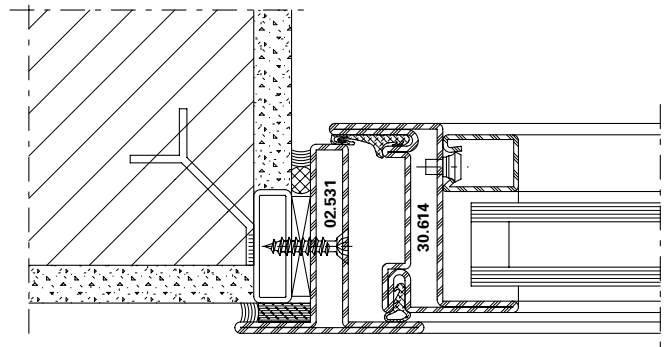

DXF **DWG** 23-0101-A-008

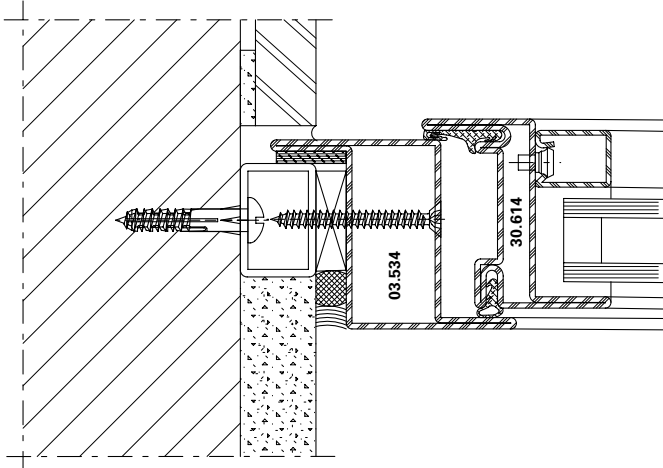

DXF **DWG** 23-0101-A-009

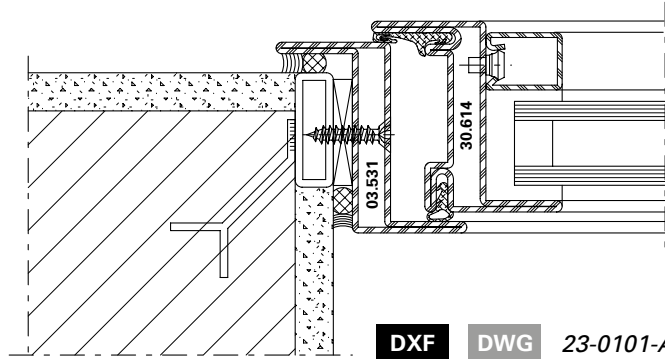

DXF **DWG** 23-0101-A-010

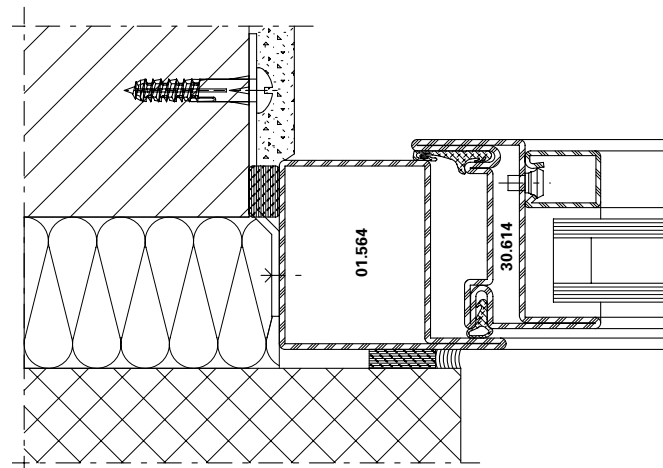

DXF **DWG** 23-0101-A-011

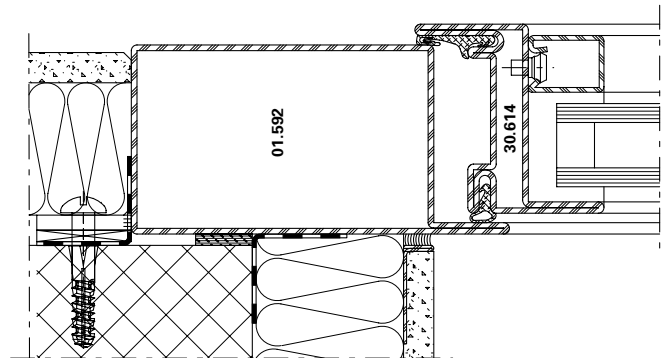

DXF **DWG** 23-0101-A-012

Anschlüsse am Bau im Masstab 1:2
Raccords au mur à l'échelle 1:2
Attachment to structure on scale 1:2

Jansen Art'System
Jansen Art'System
Jansen Art'System

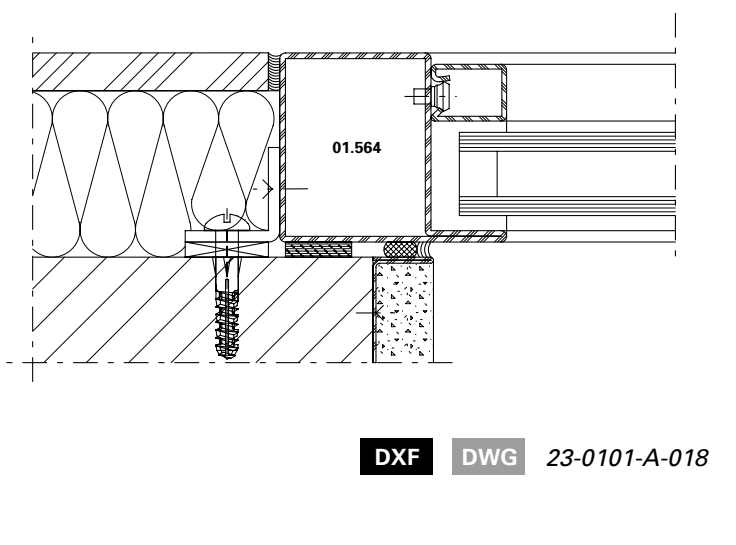
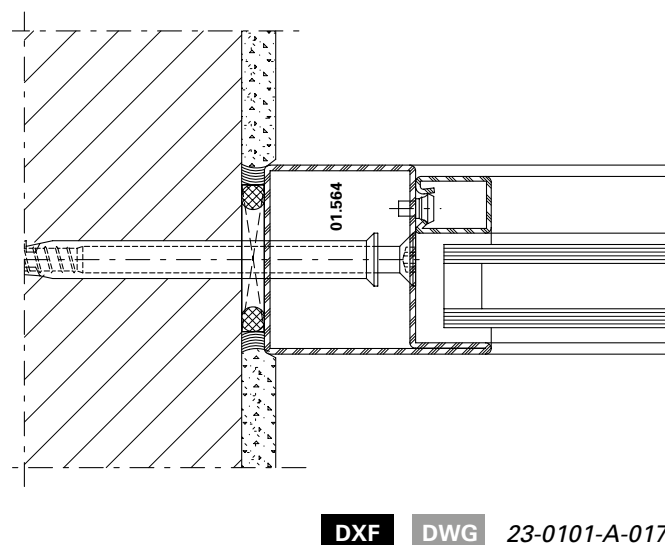
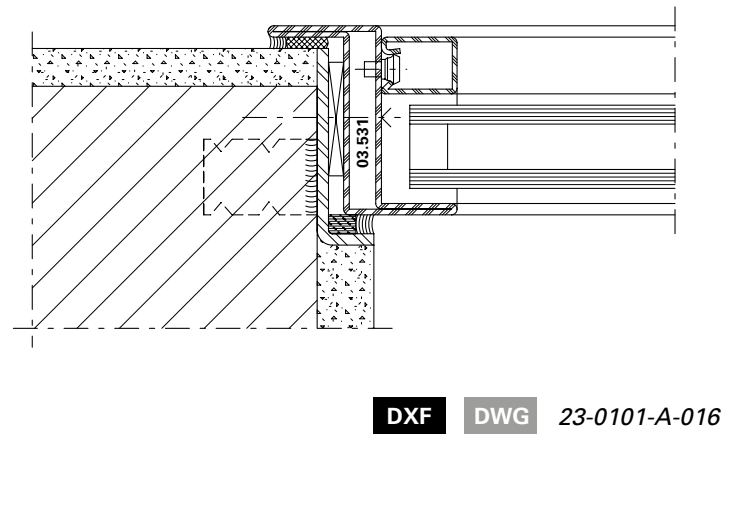
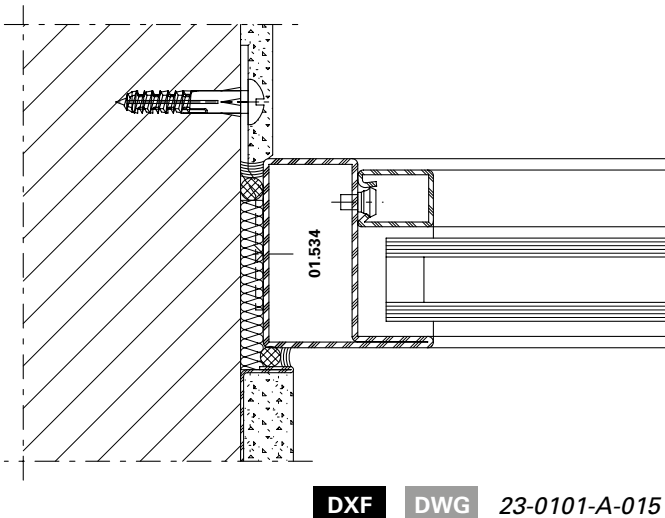
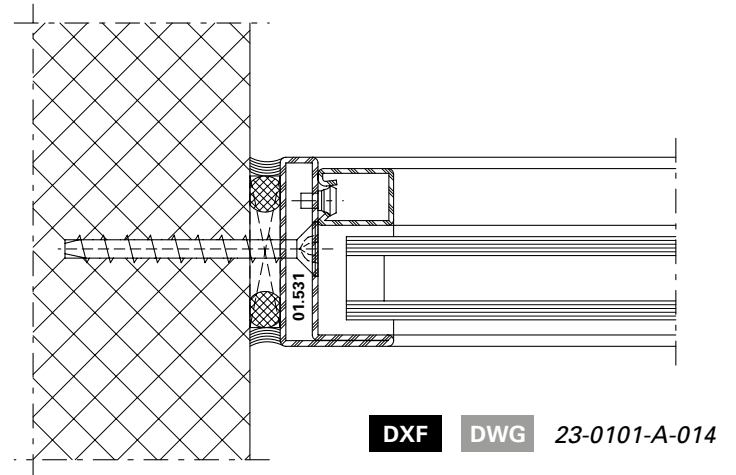
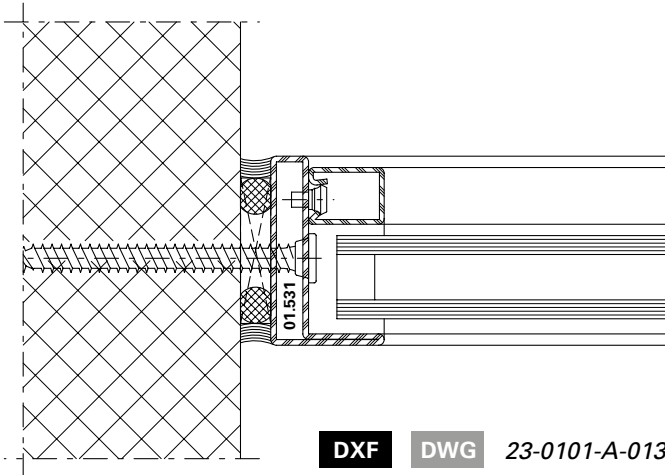

Anschlüsse am Bau im Masstab 1:2
Raccords au mur à l'échelle 1:2
Attachment to structure on scale 1:2

Jansen Art'System
Jansen Art'System
Jansen Art'System

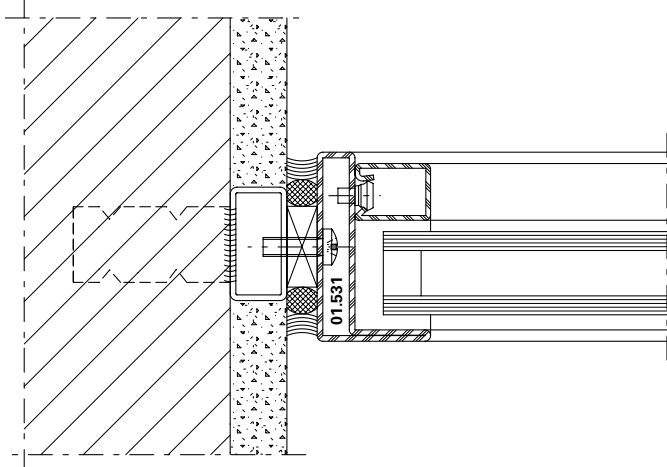

DXF DWG 23-0101-A-019

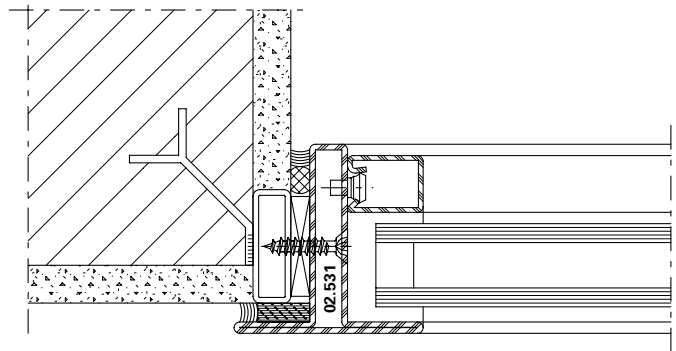

DXF DWG 23-0101-A-020

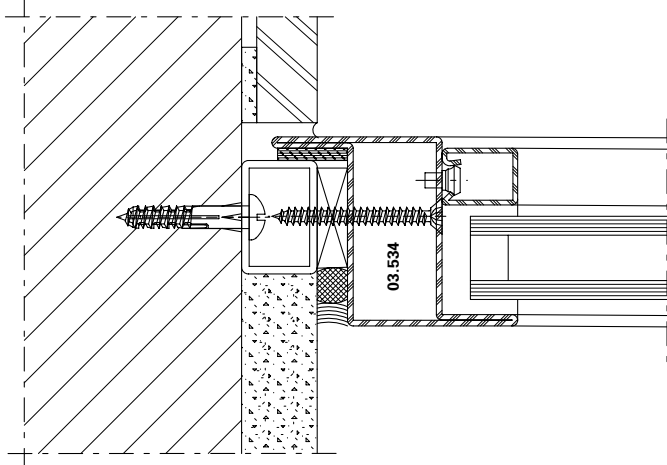

DXF DWG 23-0101-A-021

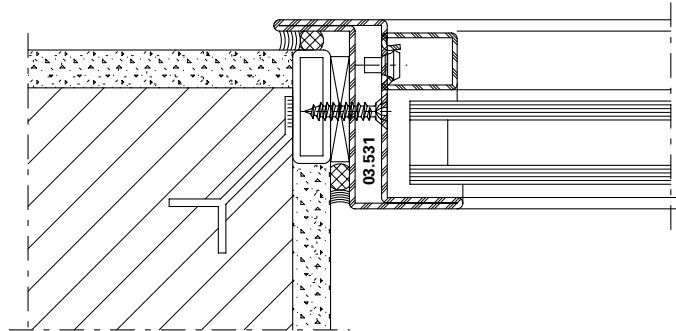

DXF DWG 23-0101-A-022

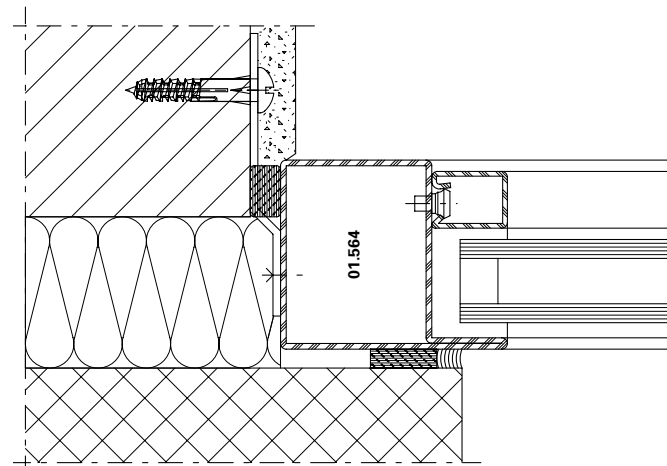

DXF DWG 23-0101-A-023

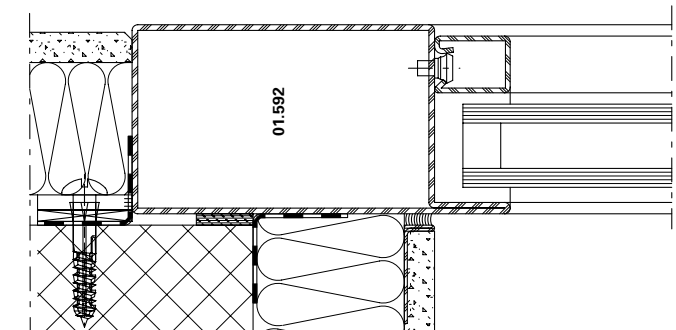

DXF DWG 23-0101-A-024

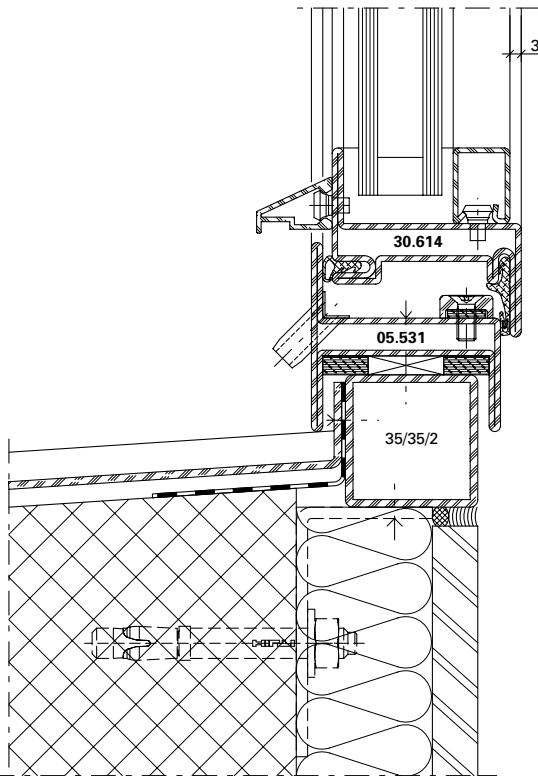

DXF **DWG** 23-0101-A-025

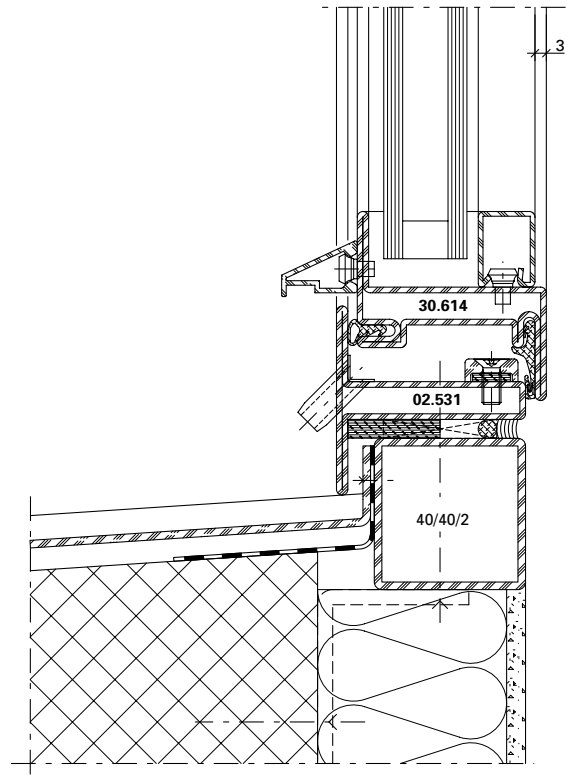

DXF **DWG** 23-0101-A-026

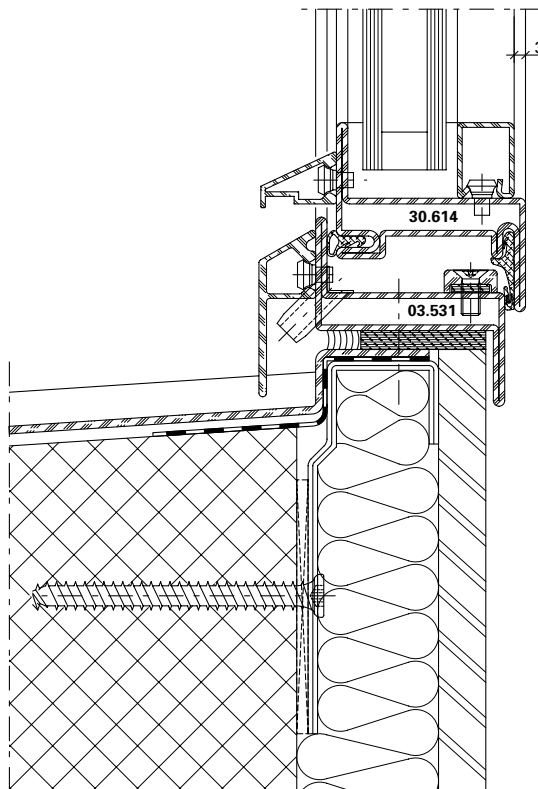

DXF **DWG** 23-0101-A-027

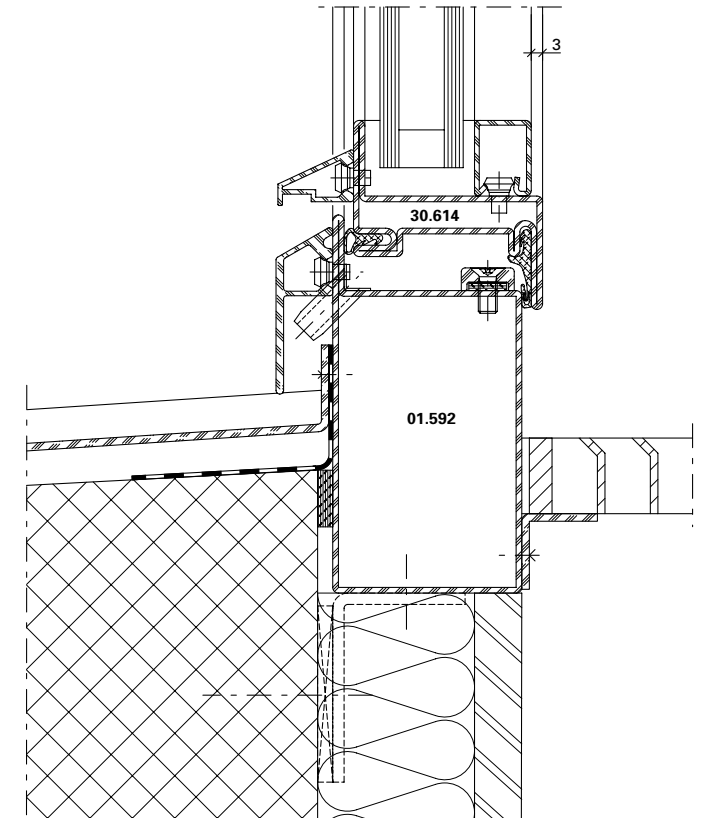

DXF **DWG** 23-0101-A-028

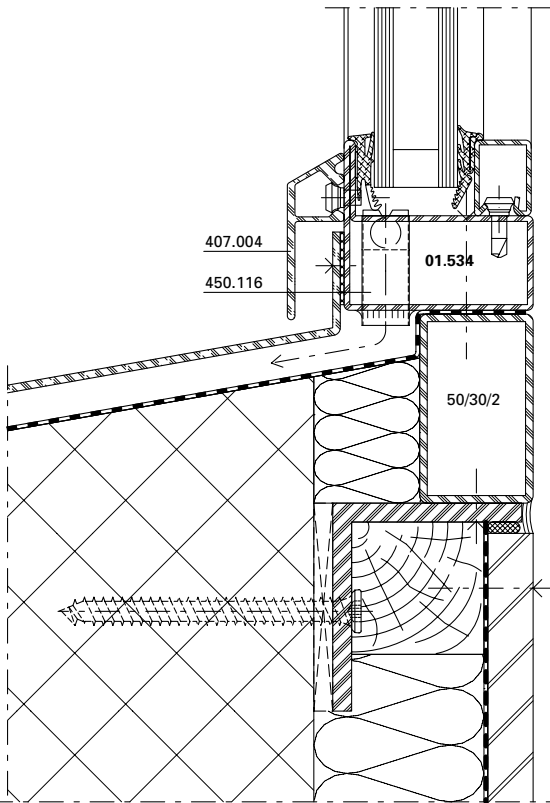

DXF DWG 23-0101-A-031

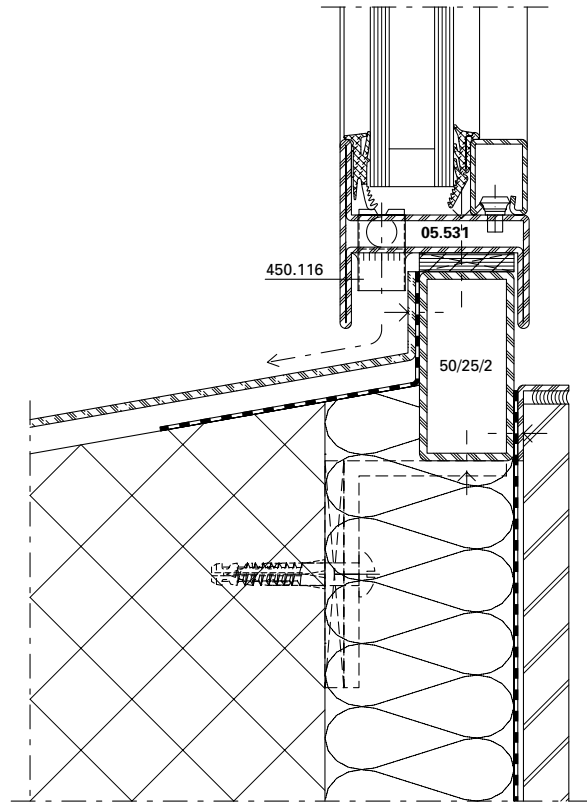

DXF DWG 23-0101-A-032

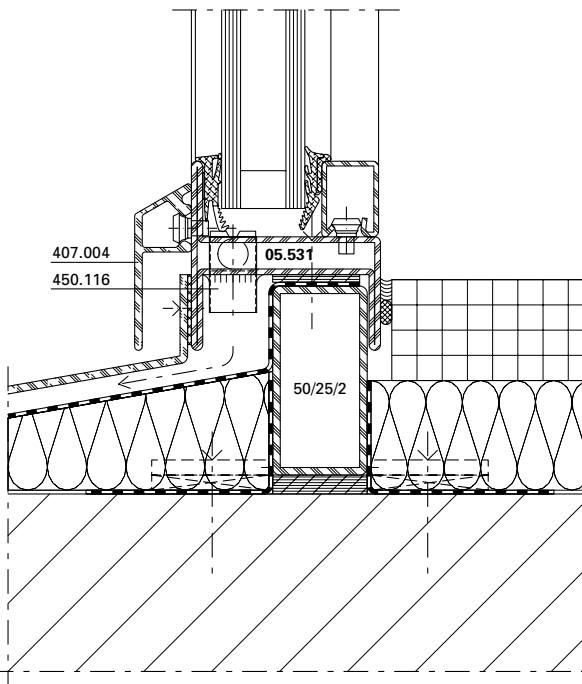

DXF DWG 23-0101-A-033

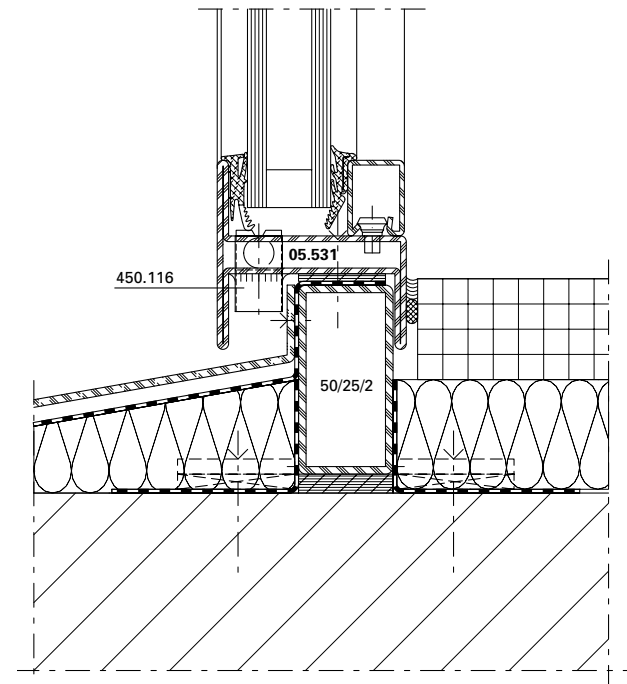

DXF DWG 23-0101-A-034

Schlagregendichtheit
Luftdurchlässigkeit
Widerstand bei Windlast

Etanchéité à la pluie battante
Perméabilité à l'air
Résistance à la pression du vent

Watertightness
Air permeability
Resistance to wind load

Fenster nach innen öffnend

Fenêtre ouvrant vers l'intérieur



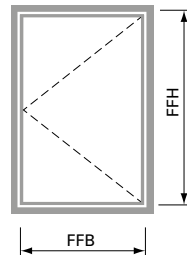

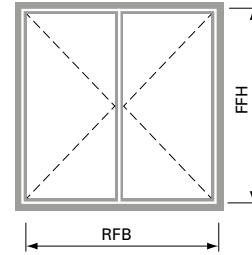

Inward opening window



FFB = 310 - 872 mm
 FFH = 310 - 2072 mm

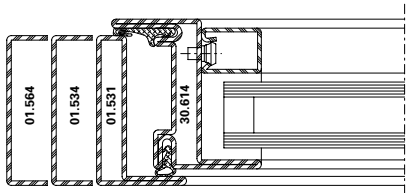
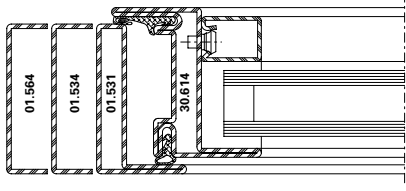

RFB = 665 - 1789 mm
 FFH = 310 - 2072 mm

	 EN 12208	 EN 12207	 EN 12210	 EN 12208	 EN 12207	 EN 12210
FFB bis 772 mm / FFH bis 1572 mm FFB jusqu'à 772 mm / FFH jusqu'à 1572 mm FFB up to 772 mm / FFH up to 1572 mm 	Klasse 7A Classe 7A Class 7A	Klasse 4 Classe 4 Class 4	Klasse C5/B5 Classe C5/B5 Class C5/B5	Klasse 7A Classe 7A Class 7A	Klasse 4 Classe 4 Class 4	Klasse C3/B3 Classe C3/B3 Class C3/B3
FFB bis 872 mm / FFH bis 2072 mm FFB jusqu'à 872 mm / FFH jusqu'à 2072 mm FFB up to 872 mm / FFH up to 2072 mm 	Klasse 7A Classe 7A Class 7A	Klasse 4 Classe 4 Class 4	Klasse C3/B3 Classe C3/B3 Class C3/B3	Klasse 7A Classe 7A Class 7A	Klasse 4 Classe 4 Class 4	Klasse C3/B3 Classe C3/B3 Class C3/B3

Schlagregendichtheit
Luftdurchlässigkeit
Widerstand bei Windlast

Etanchéité à la pluie battante
Perméabilité à l'air
Résistance à la pression du vent

Watertightness
Air permeability
Resistance to wind load





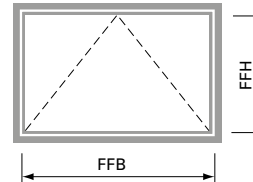
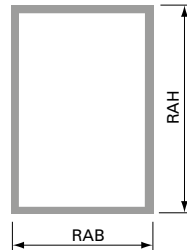

Fenster nach innen öffnend

Fenêtre ouvrant vers l'intérieur

Inward opening window





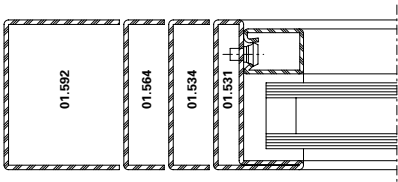
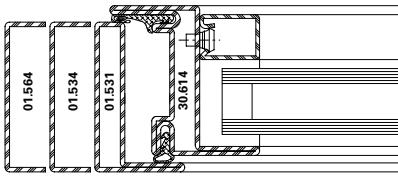
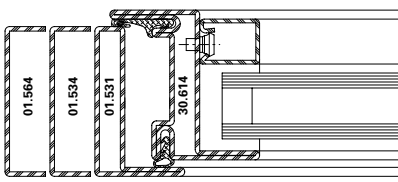

Max.:
 1572x772 mm / 772x1572 (FFBxFFH)
 oder/ou/or
 2072x872 mm / 872x1980 (FFBxFFH)

	 EN 12208	 EN 12207	 EN 12210	 EN 12208	 EN 12207	 EN 12210
	Klasse 7A Classe 7A Class 7A	Klasse 4 Classe 4 Class 4	Klasse C5/B5 Classe C5/B5 Class C5/B5			
	Mehrpunktverschluss verdeckt liegend Verrouillage multipoints non apparente Multi-point wlocking concealed FFBxFFH 1572x772 mm			Aufgesetzter Beschlag Ferure plaquée Surface-mounted fitting FFBxFFH 1572x772 mm / 772x1572 mm		
	Klasse 6A Classe 6A Class 6A	Klasse 4 Classe 4 Class 4	Klasse C5/B5 Classe C5/B5 Class C5/B5	Klasse 6A Classe 6A Class 6A	Klasse 4 Classe 4 Class 4	Klasse C5/B5 Classe C5/B5 Class C5/B5
	FFBxFFH 2072x872 mm			FFBxFFH 1980x872 mm / 872x1980 mm		
	Klasse 6A Classe 6A Class 6A	Klasse 4 Classe 4 Class 4	Klasse C3/B3 Classe C3/B3 Class C3/B3	Klasse 6A Classe 6A Class 6A	Klasse 4 Classe 4 Class 4	Klasse C3/B3 Classe C3/B3 Class C3/B3

U_f-Werte
 (nach EN ISO 10077-2:2018-01)

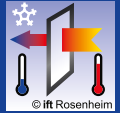
Valeurs U_f
 (selon EN ISO 10077-2:2018-01)

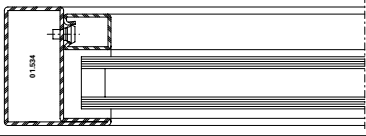
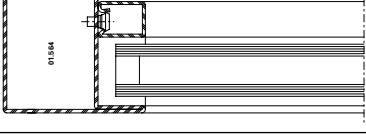
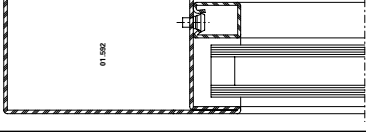
U_f values
 (according to EN ISO 10077-2:2018-01)

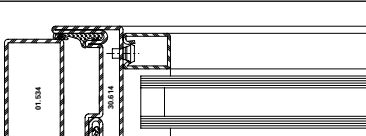
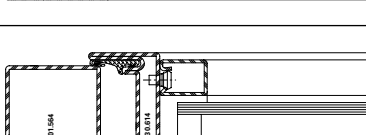
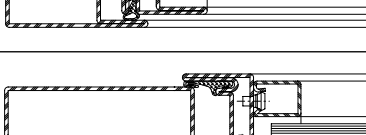
	Füllelementstärken Elements de remplissages Infill elements ≥ 22 mm
	7,2 W/m²K
	6,2 W/m²K
	6,0 W/m²K
	5,2 W/m²K
	6,3 W/m²K
	6,1 W/m²K
	6,0 W/m²K
	5,4 W/m²K

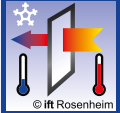
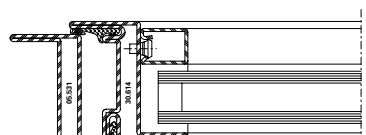
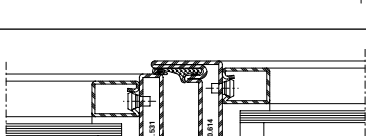
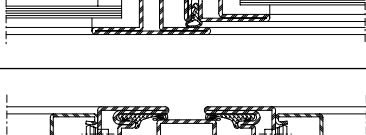
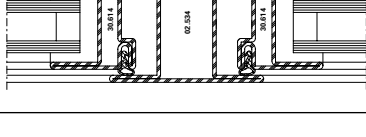
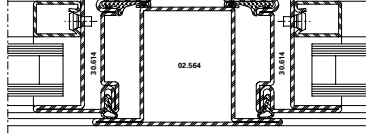
	Füllelementstärken Elements de remplissages Infill elements ≥ 22 mm
	6,1 W/m²K
	6,7 W/m²K
	6,2 W/m²K
	6,1 W/m²K
	6,8 W/m²K

Die Werte gelten für Trockenverglasung mit Stahl-Glasleisten
 Les valeurs sont valable pour vitrage à sec avec parclozes en acier
 The values are valid for dry glazing with steel glazing beads

U_f-Werte
 (nach EN ISO 10077-2:2018-01)

Valeurs U_f
 (selon EN ISO 10077-2:2018-01)

U_f values
 (according to EN ISO 10077-2:2018-01)

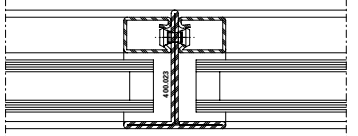
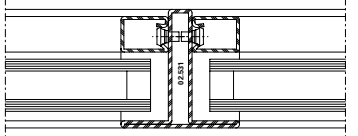
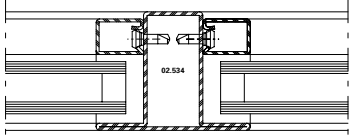
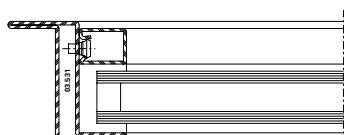
	Füllelementstärken Elements de remplissages Infill elements ≥ 22 mm
	7,6 W/m²K
	7,2 W/m²K
	6,6 W/m²K
	5,7 W/m²K

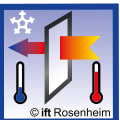
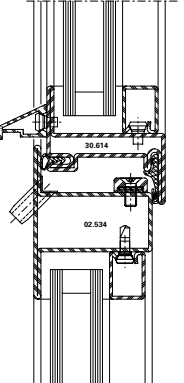
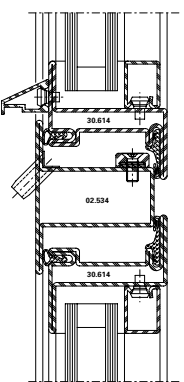
	Füllelementstärken Elements de remplissages Infill elements ≥ 22 mm
	6,8 W/m²K
	6,2 W/m²K

Die Werte gelten für Trockenverglasung mit Stahl-Glasleisten
 Les valeurs sont valable pour vitrage à sec avec parcloles en acier
 The values are valid for dry glazing with steel glazing beads

Die hier dargestellten U_f-Werte basieren auf internen Berechnungen (EN ISO 10077-2), welche mit Prüfnachweisen vom ift Rosenheim korrelieren.

Les valeurs U_f ici illustrées se basent sur des calculs internes (EN ISO 10077-2) en corrélation avec les preuves d'essai de l'ift Rosenheim.

The U_f values illustrated here are based on internal calculations (EN ISO 10077-2), which correlate with test certificates from ift Rosenheim.



Schalldämmung

Ausführungsvarianten

Die nachfolgende Typenübersicht ergibt einen Überblick über die beurteilten Varianten.



Tabelle A1

Korrekturtabelle für Art'System Fenster mit Mehrscheibenisoliervglas

Tableau A1

Tableau de correction pour les fenêtres Art'System avec vitrage isolant multi-vitres

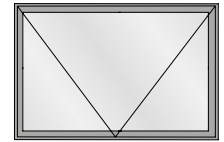
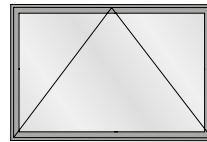
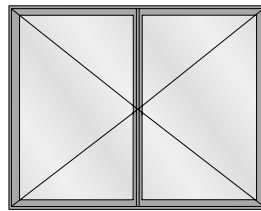
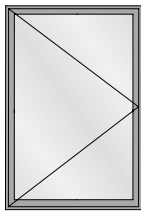
Table A1

Correction table for Art'System windows with multi-pane insulating glass

	1	2	3	4	5	6	7	8	9	10
	Fenster Fenêtre Window	Isolierglaseinheit Unité d'isolation Insulating glass unit	Korrekturen Corrections Corrections							
	R_W (C, Ctr) dB	R_{W, P, Glas} dB	K_{RA} dB	K_{RA+} dB	K_{RA++} dB	K_S dB	K_{G 0,4} dB	K_{G 2,1} dB	K_{G 2,9} dB	K_{G 3,7} dB
1	31 (-1; -5)	31	-1	0	0	0	0	-1	-2	-3
2	32 (-1; -5)	32	-1	0	0	0	0	-1	-2	-3
3	33 (-1; -5)	33	-1	0	0	0	0	-1	-2	-3
4	34 (-1; -5)	34	-1	0	0	0	0	-1	-2	-3
5	34 (-1; -5)	35	-1	0	0	0	0	-1	-2	-3
6	35 (-1; -5)	36	0	0	0	0	0	-1	-2	-3
7	36 (-1; -5)	37	0	0	0	0	0	-1	-2	-3
8	36 (-1; -5)	38	0	0	0	0	0	-1	-2	-3
9	37 (-1; -5)	39	0	0	0	0	0	-1	-2	-3
10	38 (-1; -5)	40	0	0	0	0	0	-1	-2	-3
11	39 (-1; -5)	41	0	0	0	0	-1	-1	-2	-3
12	40 (-2; -6)	42	0	0	-1	0	-2	-1	-2	-3
13	40 (-2; -6)	43	0	0	-1	0	-2	-1	-2	-3
14	41 (-2; -6)	44	0	0	-1	0	-2	-1	-2	-3
15	42 (-2; -6)	45	0	-1	-2	0	-2	-1	-2	-3
16	43 (-2; -6)	46	0	-1	-2	-1	-2	-1	-2	-3

Das bewertete Schalldämm-Mass $R_{W, Fenster}$ einer Ausführungsvariante unter Berücksichtigung der Korrekturen für besondere Ausführungsmerkmale nach Tabelle A1, Spalten 3-10 beträgt:

La cote d'isolation acoustique du vitrage évalué $R_{W, fenêtre}$ d'une variante prenant en compte les corrections pour caractéristiques particulières selon le tableau A1, colonnes 3 à 10 est la suivante:

The weighted sound reduction index $R_{w, Window}$ of a design option taking into consideration the corrections for special design features in accordance with table A1, columns 3-10, is:

$$R_{W, Fenster} = R_W + K_{RA} + K_{RA+} + K_{RA++} + K_S + K_{G 0,4} + K_{G 2,1} + K_{G 2,9} + K_{G 3,7} \text{ dB}$$

R_W bewertetes Schalldämm-Mass der Basisausführung in Abhängigkeit von der Schalldämmung $R_{W,P, Glas}$ der Verglasung (nach Tabelle A1, Spalte 1)

R_W bewertetes Schalldämm-Mass der Basisausführung in Abhängigkeit von der Schalldämmung $R_{W,P, Glas}$ der Verglasung (nach Tabelle A1, Spalte 1)

R_W Weighted sound reduction index of the basic version depending on the sound reduction $R_{W,P, Glass}$ of the glazing (in accordance with table A1, column 1)

$R_{W,P, Glas}$ bewertetes Schalldämm-Mass der Verglasung (Prüfwert nach EN ISO 10140-2, mit Prüfnachweis einer anerkannten PÜZ-Stelle). Alternativ können Tabellenwerte nach DIN EN 12758, Abschnitt 6 verwendet werden.

$R_{W,P, Glas}$ bewertetes Schalldämm-Mass der Verglasung (Prüfwert nach EN ISO 10140-2, mit Prüfnachweis einer anerkannten PÜZ-Stelle). Alternativ können Tabellenwerte nach DIN EN 12758, Abschnitt 6 verwendet werden.

$R_{W,P, Glass}$ Weighted sound reduction index of the glazing (test value in accordance with EN ISO 10140-2, with test certificate from a recognised testing, monitoring and certification body). Alternatively, the table values in accordance with DIN EN 12758, section 6 can be used.

K_{RA} Korrekturwert für Rahmenanteil $p < 10\%$ ¹⁾. **K_{RA}** gilt gleichermaßen für Elemente mit beweglichen Flügeln und für festverglaste Wandelemente (Seiten-/Oberteile).

K_{RA+} Korrekturwert für Rahmenanteil $25\% \leq p \leq 35\%$ ¹⁾. **K_{RA+}** gilt gleichermaßen für Elemente mit beweglichen Flügeln und für festverglaste Wandelemente (Seiten-/Oberteile).

K_{RA++} Korrekturwert für Rahmenanteil $p > 35\%$ ¹⁾. **K_{RA++}** gilt gleichermaßen für Elemente mit beweglichen Flügeln und für festverglaste Wandelemente (Seiten-/Oberteile).

K_S Korrekturwert für zweiflügelige Fenster mit Stulp.

K_{G 0.4} Korrekturwert für Einzelscheiben mit einer Glasfläche $\leq 0,4 \text{ m}^2$. Die Korrektur gilt auch für Konstruktionen mit glasteilenden Sprossen (verfügbare Glasabmessungen ab $b \times h \geq 400 \text{ mm} \times 400 \text{ mm} = 0,16 \text{ m}^2$).

K_{G 2.1} Korrekturwert für Einzelscheiben mit einer Glasfläche $\geq 2,1 \text{ m}^2$

K_{G 2.9} Korrekturwert für Einzelscheiben mit einer Glasfläche $\geq 2,9 \text{ m}^2$

K_{G 3.7} Korrekturwert für Einzelscheiben mit einer Glasfläche $\geq 3,7 \text{ m}^2$ (verfügbare Glasabmessungen bis maximal $b \times h \leq 5,2 \text{ m}^2$).

¹⁾ Der Rahmenanteil p ergibt sich aus der die Gesamtfläche A_{ges} des Elements (Rahmemaussenmass) und der sichtbaren Scheibengröße A_{Glas} (Summe aller sichtbaren Glasflächen): $p = 100 \times (A_{\text{ges}} - A_{\text{Glas}}) / A_{\text{ges}}$

K_{RA} Valeur de correction pour la part afférente au châssis $p < 10\%$ ¹⁾. **K_{RA}** est de la même façon valable pour les éléments à vantaux mobiles et pour les éléments muraux à vitrage fixe (éléments latéraux/impostes).

K_{RA+} Valeur de correction pour la part afférente au châssis $p \leq 35\%$ ¹⁾. **K_{RA+}** est de la même façon valable pour les éléments à vantaux mobiles et pour les éléments muraux à vitrage fixe (éléments latéraux/impostes).

K_{RA++} Valeur de correction pour la part afférente au châssis $p > 35\%$ ¹⁾. **K_{RA++}** est de la même façon valable pour les éléments à vantaux mobiles et pour les éléments muraux à vitrage fixe (éléments latéraux/impostes).

K_S Valeur de correction pour fenêtres à deux vantaux avec recouvrement.

K_{G 0.4} Valeur de correction pour vitres individuelles d'une surface vitrée $\leq 0,4 \text{ m}^2$. La correction s'applique aussi aux constructions avec petits bois séparant les carreaux (dimensions vitrées disponibles à partir de $l \times h \geq 400 \text{ mm} \times 400 \text{ mm} = 0,16 \text{ m}^2$).

K_{G 2.1} Valeur de correction pour vitres individuelles d'une surface vitrée $\geq 2,1 \text{ m}^2$

K_{G 2.9} Valeur de correction pour vitres individuelles d'une surface vitrée $\geq 2,9 \text{ m}^2$

K_{G 3.7} Valeur de correction pour vitres individuelles d'une surface vitrée $\geq 3,7 \text{ m}^2$ (dimensions vitrées disponibles jusqu'à $l \times h \leq 5,2 \text{ m}^2$).

¹⁾ La part afférente au châssis p résulte de la surface totale A_{tot} de l'élément (dimensions hors-tout du châssis) et de la taille visible du vitrage A_{verre} (total de toutes les surfaces vitrées visibles):
 $p = 100 \times (A_{\text{tot}} - A_{\text{verre}}) / A_{\text{tot}}$

K_{RA} correction value for frame ratio $p < 10\%$ ¹⁾. **K_{RA}** applies also to units with moving casements and fixed lights installed in walls (sidelights/toplights).

K_{RA+} correction value for frame ratio $25\% \leq p \leq 35\%$ ¹⁾. **K_{RA+}** applies also to units with moving casements and fixed lights installed in walls (sidelights/toplights).

K_{RA++} correction value for frame ratio $p > 35\%$ ¹⁾. **K_{RA++}** applies also to units with moving casements and fixed lights installed in walls (sidelights/toplights).

K_S correction value for double windows of overlapping design.

K_{G 0.4} correction value for individual panes of glass area $\leq 0,4 \text{ m}^2$. Correction applies also to designs with glass dividing bars (available glass dimensions from $w \times h \geq 400 \text{ mm} \times 400 \text{ mm} = 0,16 \text{ m}^2$).

K_{G 2.1} correction value for individual panes of glass area $\geq 2,1 \text{ m}^2$

K_{G 2.9} correction value for individual panes of glass area $\geq 2,9 \text{ m}^2$

K_{G 3.7} correction value for individual panes of glass area $\geq 3,7 \text{ m}^2$ (available glass dimensions up to max. $w \times h \leq 5,2 \text{ m}^2$).

¹⁾ The frame ratio is evaluated with the total area A_{total} of the unit (overall frame dimensions) and the visible pane size A_{glass} (total of all visible glass areas):
 $P = 100 \times (A_{\text{total}} - A_{\text{glass}}) / A_{\text{total}}$

Inhaltsverzeichnis	Sommaire	Content	
Anordnung und Anzahl der Bänder	Nombre et emplacement des paumelles	Number and arrangement of hinges	118
Montage Anschweissbänder 557.266 / 557.267	Montage des paumelles à souder 557.266 / 557.267	Installation of weld-on hinges 557.266 / 557.267	119
Montage Anschweissband 555.483	Montage de paumelle à souder 555.483	Installation of weld-on hinge 555.483	120
Montage Anschweissband 550.209	Montage de paumelle à souder 550.209	Installation of weld-on hinges 550.209	121
Montage Anschweissband 550.210	Montage de paumelle à souder 550.210	Installation of weld-on hinge 550.210	122
Montage Anschweissband 557.265	Montage de paumelle à souder 557.265	Installation of weld-on hinge 557.265	123
Aufgesetzter Fensterbeschlag Fenster einflügelig	Ferrure de fenêtre plaquée Fenêtre à un vantail	Surface-mounted window fitting Single-vent window	124
Aufgesetzter Fensterbeschlag Fenster zweiflügelig	Ferrure de fenêtre plaquée Fenêtre à deux vantaux	Surface-mounted window fitting Double-vent window	126
Aufgesetzter Fensterbeschlag Längenbestimmung Verschlussstangen Fenster einflügelig	Ferrure de fenêtre plaquée Détermination de la longueur barre de fermeture Fenêtre à un vantail	Surface-mounted window fitting Length specification of closing bars Single-vent window	128
Aufgesetzter Fensterbeschlag Längenbestimmung Verschlussstangen Fenster zweiflügelig	Ferrure de fenêtre plaquée Détermination de la longueur barre de fermeture Fenêtre à deux vantaux	Surface-mounted window fitting Length specification of closing bars Double-vent window	130
Einbau Anschweisslasche 557.260/261	Montage languette à souder 557.260/261	Installation of weld-on fixing bracket 557.260/261	131
Verdeckt liegender Fensterbeschlag Definition G-Mass Fenster einflügelig	Ferrure de fenêtre non apparente Définition de la mesure G Fenêtre à un vantail	Concealed window fitting Definition of G measurement Single-vent window	132
Verdeckt liegender Fensterbeschlag Definition G-Mass Fenster zweiflügelig	Ferrure de fenêtre non apparente Définition de la mesure G Fenêtre à deux vantaux	Concealed window fitting Definition of G measurement Double-vent window	133
Verdeckt liegender Fensterbeschlag Anordnung und Anzahl Verriegelungspunkte Fenster einflügelig	Ferrure de fenêtre non apparente Disposition des points de verrouillage Fenêtre à un vantail	Concealed window fitting Arrangement of locking points Single-vent window	134
Verdeckt liegender Fensterbeschlag Anordnung und Anzahl Verriegelungspun Fenster zweiflügelig	Ferrure de fenêtre non apparente Disposition des points de verrouillage Fenêtre à deux vantaux	Concealed window fitting Arrangement of locking points Double-vent window	135

Inhaltsverzeichnis	Sommaire	Content	
Verdeckt liegender Fensterbeschlag Fenster einflügelig Zusatzverriegelung mittig	Ferrure de fenêtre non apparente Fenêtre à un vantail Verrouillage centre	Concealed window fitting Single-vent window Locking point (centre)	136
Verdeckt liegender Fensterbeschlag Fenster einflügelig Zusatzverriegelung oben	Ferrure de fenêtre non apparente Fenêtre à un vantail Verrouillage supplémentaire en haut	Concealed window fitting Single-vent window Additional locking point (top)	138
Verdeckt liegender Fensterbeschlag Fenster einflügelig Zusatzverriegelung unten	Ferrure de fenêtre non apparente Fenêtre à un vantail Verrouillage supplémentaire en bas	Concealed window fitting Single-vent window Additional locking point (bottom)	140
Verdeckt liegender Fensterbeschlag Fenster zweiflügelig Zusatzverriegelung mittig	Ferrure de fenêtre non apparente Fenêtre à deux vantaux Verrouillage centre	Concealed window fitting Double-vent window Locking point (centre)	142
Verdeckt liegender Fensterbeschlag Einbau Kantenriegel 557.192	Ferrure de fenêtre non apparente Montage verrou à bascule 557.192	Concealed window fitting Installation flush bolt 557.192	144
Verdeckt liegender Fensterbeschlag Einbau Schliesshülse 557.192/557.139	Ferrure de fenêtre non apparente Montage gâche 557.192/557.139	Concealed window fitting Installation locking sleeve 557.192/557.139	145
Verdeckt liegender Fensterbeschlag Verriegelung oben (Variante) 557.172 Gangflügel	Ferrure de fenêtre non apparente Verrouillage en haut (variante) 557.172 Vantail de service	Concealed window fitting Top lock (alternative) 557.172 Access leaf	146
Verdeckt liegender Fensterbeschlag Fenster zweiflügelig Zusatzverriegelung oben	Ferrure de fenêtre non apparente Fenêtre à deux vantaux Verrouillage supplémentaire en haut	Concealed window fitting Double-vent window Additional locking point (top)	148
Verdeckt liegender Fensterbeschlag Fenster zweiflügelig Zusatzverriegelung unten	Ferrure de fenêtre non apparente Fenêtre à deux vantaux Verrouillage supplémentaire en bas	Concealed window fitting Double-vent window Additional locking point (bottom)	150
Einbau Fenstergriff 557.185 und Griffmitnehmer 557.186 / 557.191	Montage poignée de fenêtre 557.185 et entraîneur de poignée 557.186 / 557.191	Installation of window handle 557.185 and handle driver 557.186 / 557.191	152
Einbau Auflaufbock 557.079	Montage bloc d'arrêt 557.079	Installation of engagement block 557.079	153
Falzschere 550.414	Compas d'arrêt pour fenêtre à soufflet 550.414	Top light stay 550.414	154
Beschlageinbau Fenstertüren Fallenriegel-Schloss 550.191 Einflügelige Türe	Montage de la ferrure portes-fenêtres Serrure à mortaiser 550.191 Porte à un vantail	Fittings installation for window doors Latch-and-bolt lock 550.191 Single-leaf door	155
Beschlageinbau Fenstertüren Rollfallen-Schloss 550.193 Einflügelige Türe	Montage de la ferrure portes-fenêtres Serrure à mortaiser à rouleau 550.193 Porte à un vantail	ittings installation for window doors Roller latch lock 550.193 Single-leaf door	156
Beschlageinbau Fenstertüren Fallenriegel-Schloss 559.210 Einflügelige Türe	Montage de la ferrure portes-fenêtres Serrure à mortaiser 559.210 Porte à un vantail	Fittings installation for window doors Latch-and-bolt lock 559.210 Single-leaf door	157
Beschlageinbau Fenstertüren Mehrfachverriegelungs-Schloss 785.008 Einflügelige Türe	Montage de la ferrure portes-fenêtres Serrure à verrouillage multiple 785.008 Porte à un vantail	Fittings installation for window doors Multi-point lock 785.008 Single-leaf door	158

Empfehlung:
Anordnung und Anzahl der Bänder

Recommandation:
Nombre et emplacement
des paumelles

Recommendation:
Number and arrangement of hinges

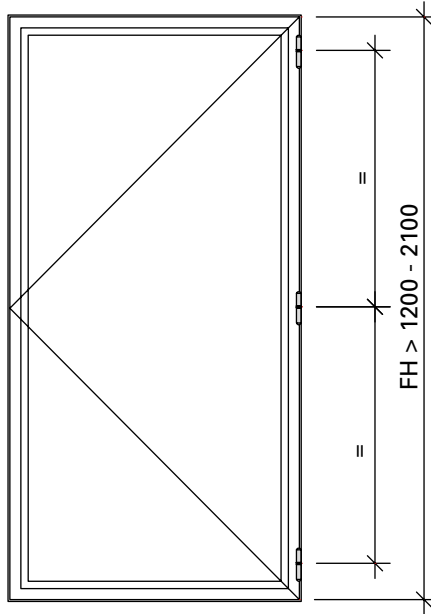
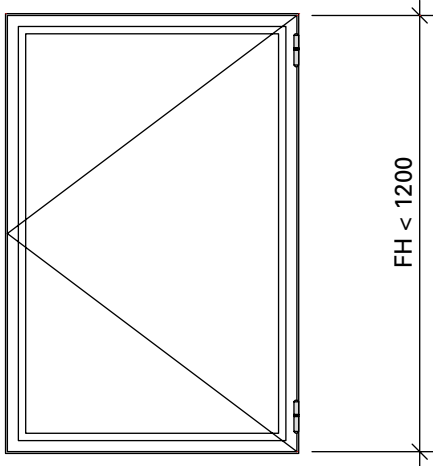

Fenstertüren
Portes-fenêtres
Windows-doors

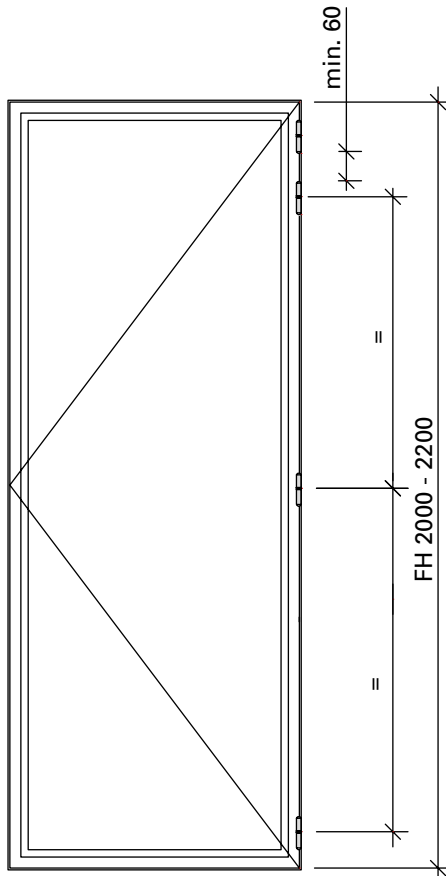

Montage Anschweissbänder
557.266 / 557.267

Montage des paumelles à souder
557.266 / 557.267

Installation of weld-on hinges
557.266 / 557.267

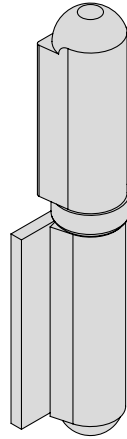
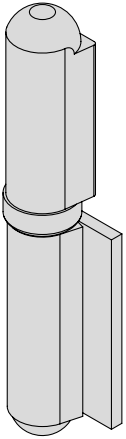

links / à gauche / left
 557.266

rechts / à droite / right
 557.267

Empfehlung Flügelgewicht:
 2 Bänder max. 60 kg
 3 Bänder max. 80 kg

Recommandation poids du vantail:
 2 paumelles max. 60 kg
 3 paumelles Max. 80 kg

Recommendation vent weight:
 2 hinges max. 60 kg
 3 hinges max. 80 kg

Ansicht von innen (Bandseite)
 Vue de l'intérieur (côté paumelle)
 View from inside (hinge side)

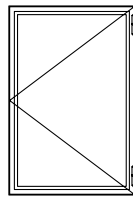
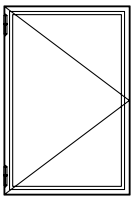

links / à gauche / left

rechts / à droite / right

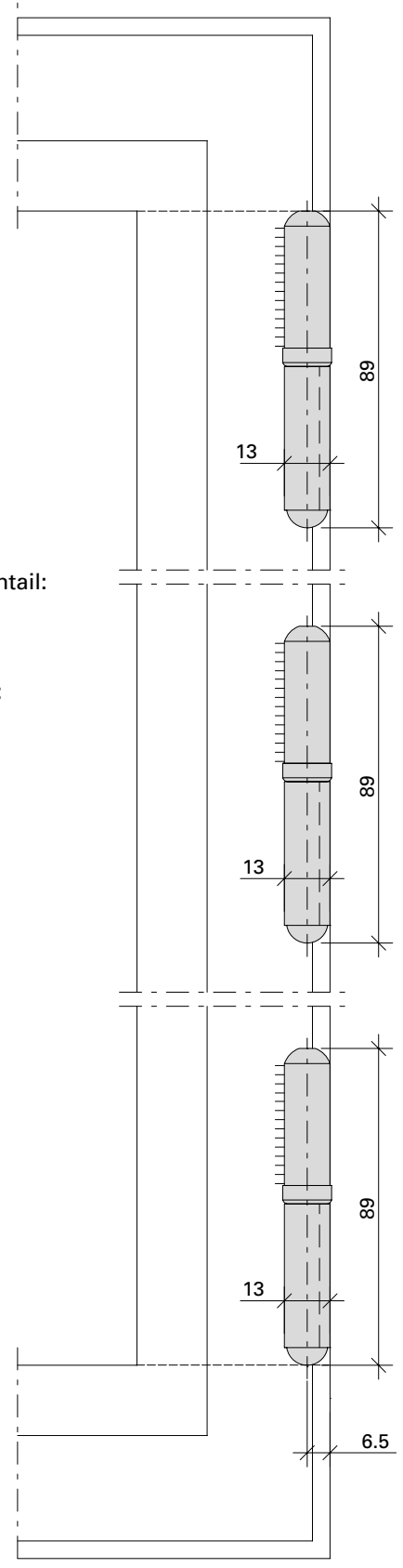
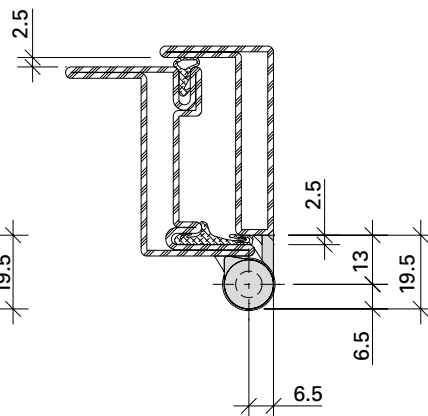
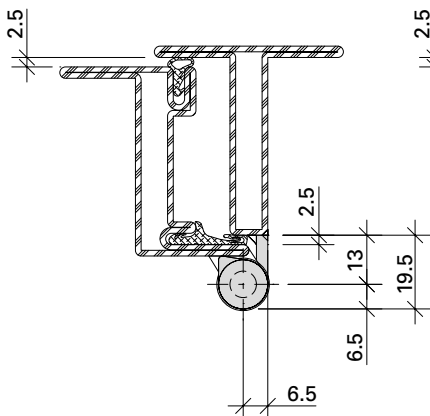

Montage Anschweissband
 555.483

Montage de paumelle à souder
 555.483

Installation of weld-on hinge
 555.483

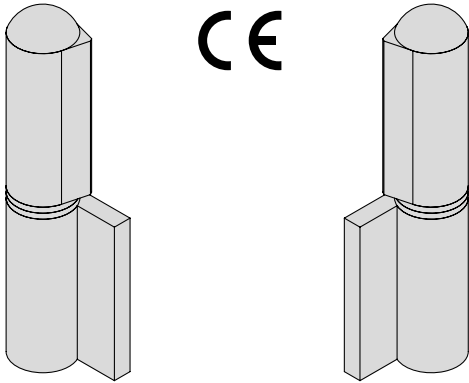

links / à gauche / left

rechts / à droite / right

Ansicht von innen (Bandseite)
 Vue de l'intérieur (côté paumelle)
 View from inside (hinge side)

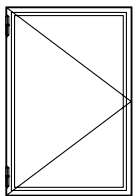

links / à gauche / left

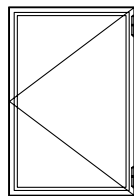

rechts / à droite / right

Empfehlung Flügelgewicht:
 2 Bänder max. 60 kg
 3 Bänder max. 60 kg

Recommandation poids du vantail:
 2 paumelles max. 60 kg
 3 paumelles max. 60 kg

Recommendation vent weight:
 2 hinges max. 60 kg
 3 hinges max. 60 kg

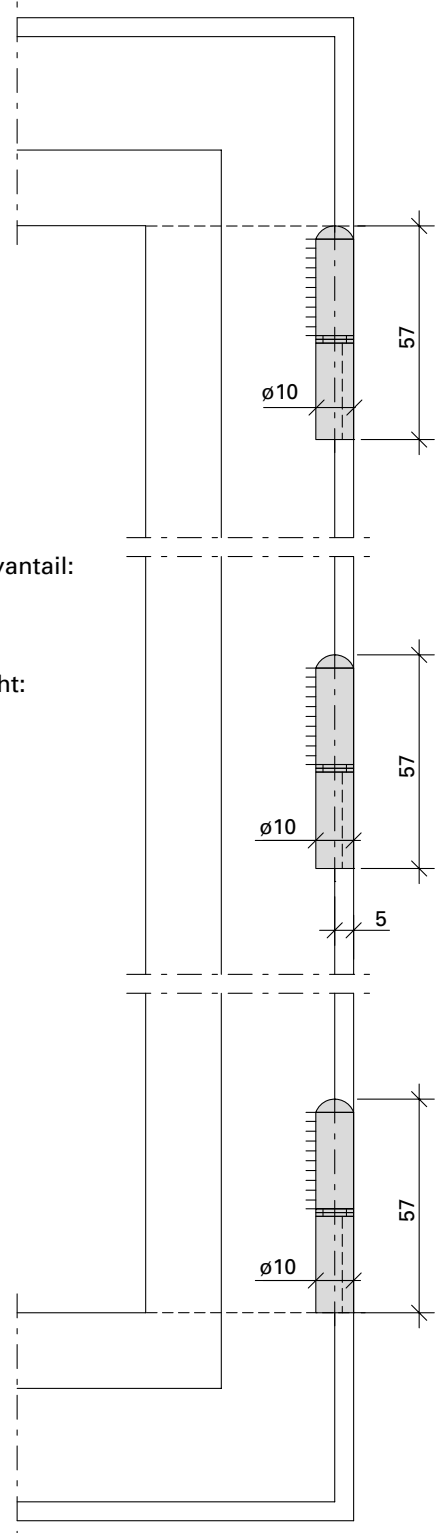
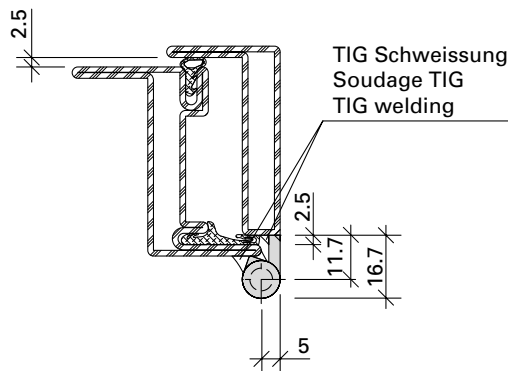
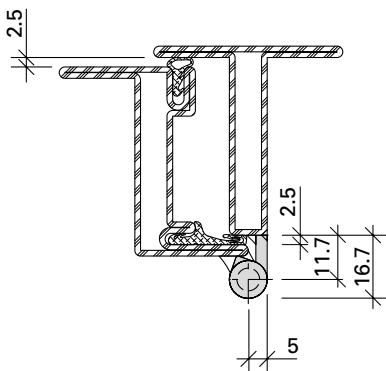

Montage Anschweisband
550.209

Montage de paumelle à souder
550.209

Installation of weld-on hinge
550.209

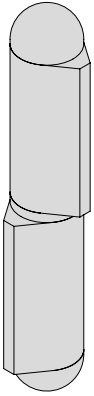

Empfehlung Flügelgewicht:
 2 Bänder max. 60 kg
 3 Bänder max. 75 kg

Recommandation poids du vantail:
 2 paumelles max. 60 kg
 3 paumelles max. 75 kg

Recommendation vent weight:
 2 hinges max. 60 kg
 3 hinges max. 75 kg

Ansicht von innen (Bandseite)
 Vue de l'intérieur (côté paumelle)
 View from inside (hinge side)

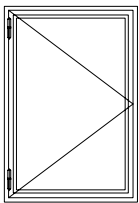

links / à gauche / left

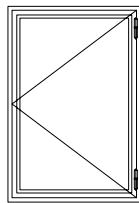

rechts / à droite / right

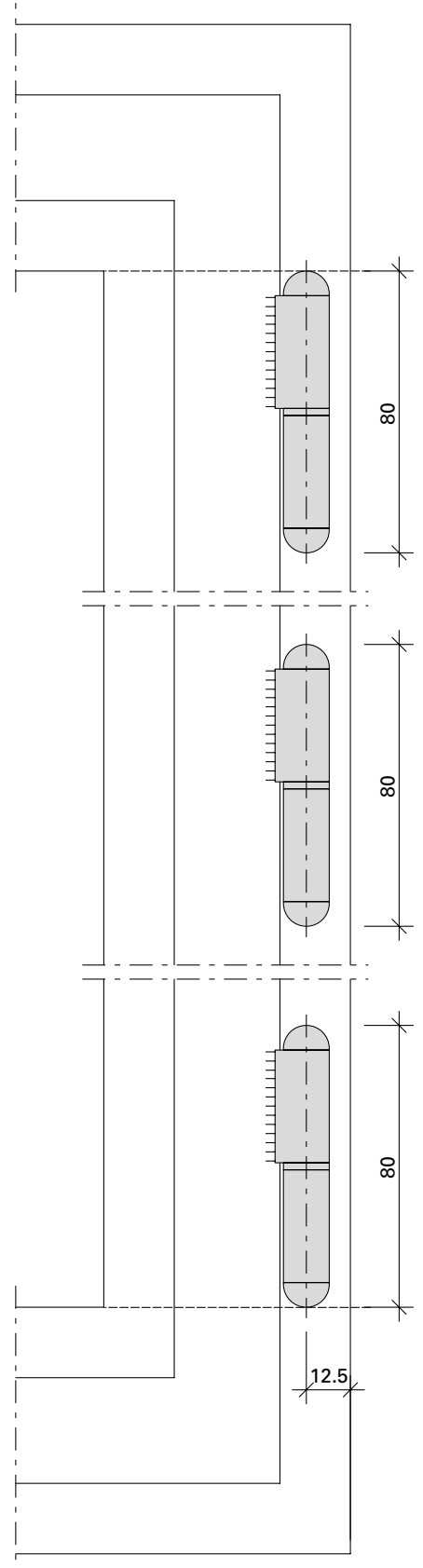
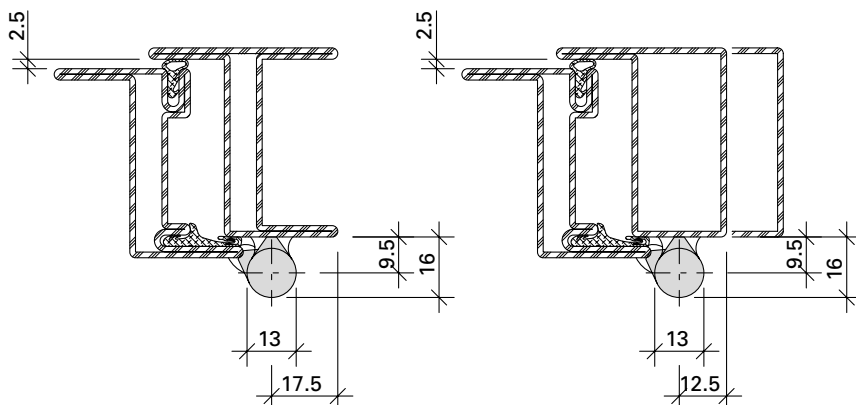

Montage Anschweissband
550.210

Montage de paumelle à souder
550.210

Installation of weld-on hinge
550.210

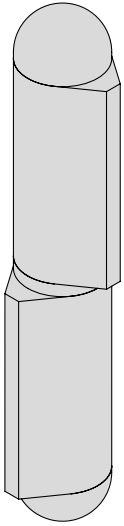

Empfehlung Flügelgewicht:
 2 Bänder max. 80 kg
 3 Bänder max. 100 kg

Recommandation poids du vantail:
 2 paumelles max. 80 kg
 3 paumelles max. 100 kg

Recommendation vent weight:
 2 hinges max. 80 kg
 3 hinges max. 100 kg

Ansicht von innen (Bandseite)
 Vue de l'intérieur (côté paumelle)
 View from inside (hinge side)

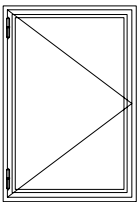

links / à gauche / left

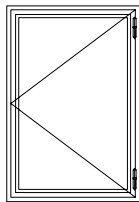

rechts / à droite / right

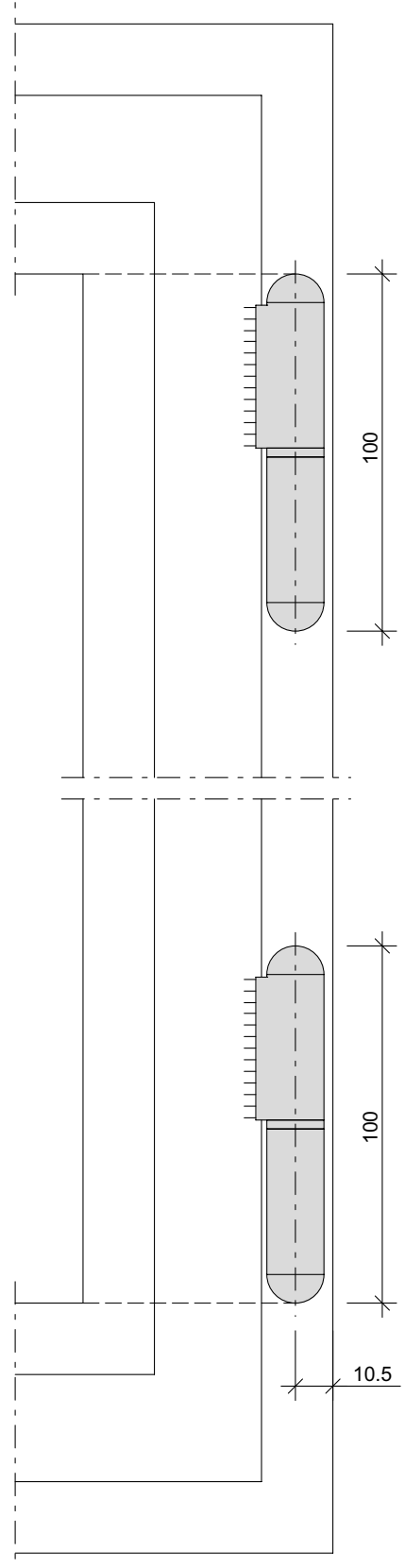
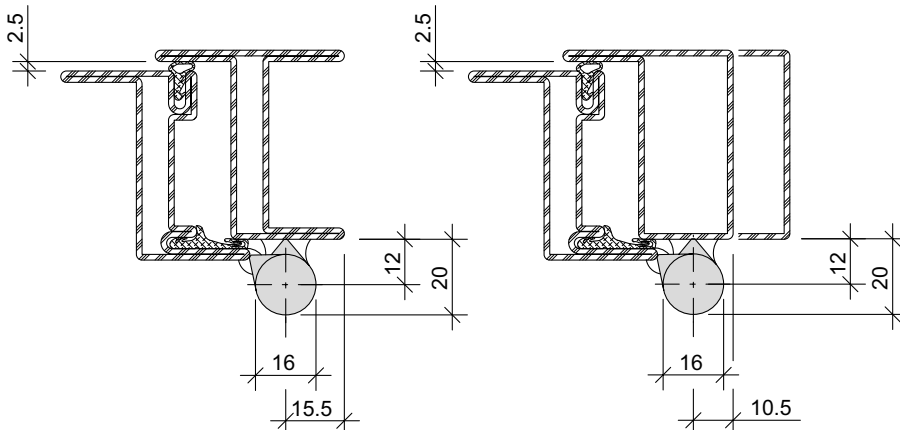

Montage Anschweissband
557.265

Montage de paumelle à souder
557.265

Installation of weld-on hinge
557.265



Empfehlung Flügelgewicht:
 2 Bänder max. 80 kg
 3 Bänder max. 100 kg

Recommandation poids du vantail:
 2 paumelles max. 80 kg
 3 paumelles max. 100 kg

Recommandation vent weight:
 2 hinges max. 80 kg
 3 hinges max. 100 kg

Ansicht von innen (Bandseite)
 Vue de l'intérieur (côté paumelle)
 View from inside (hinge side)

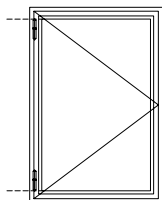

links / à gauche / left

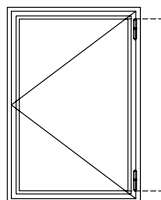

rechts / à droite / right

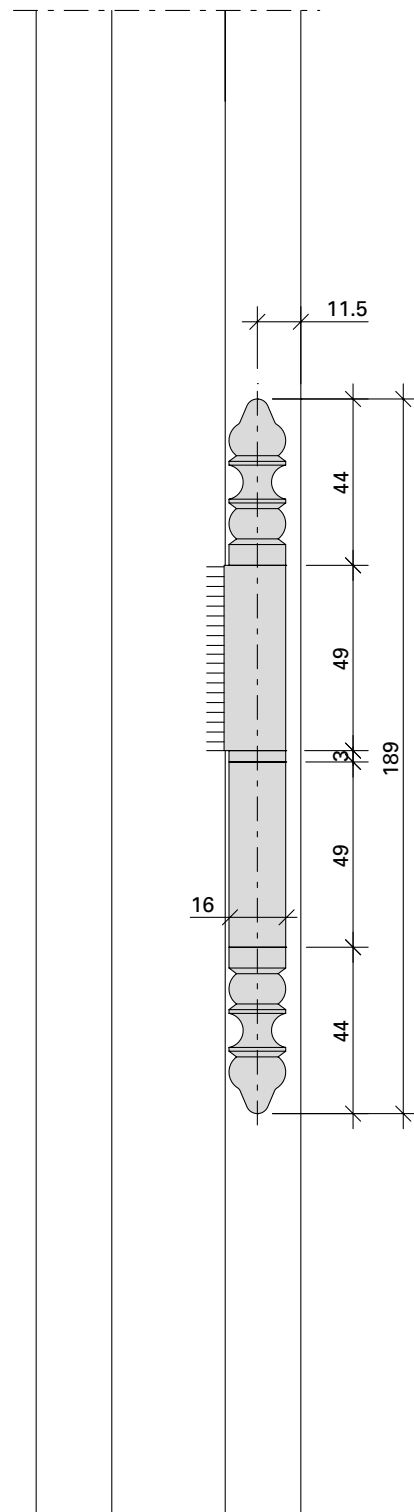
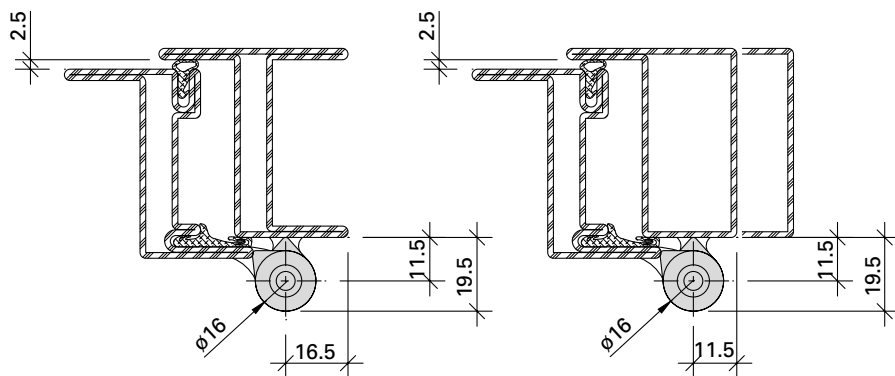

Aufgesetzter Fensterbeschlag
 Fenster einflügelig

Ferrure de fenêtre plaquée
 Fenêtre à un vantail

Surface-mounted window fitting
 Single-vent window

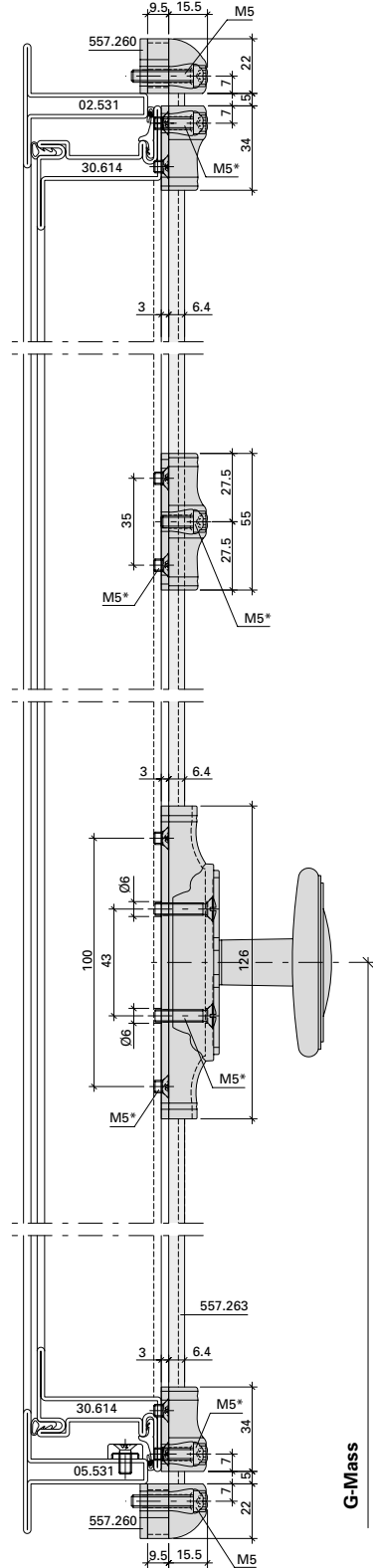
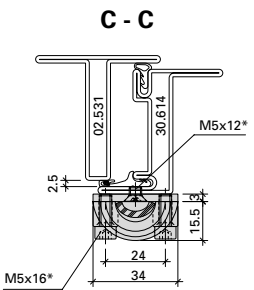
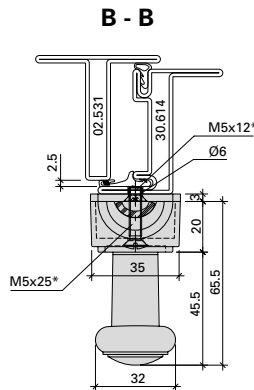
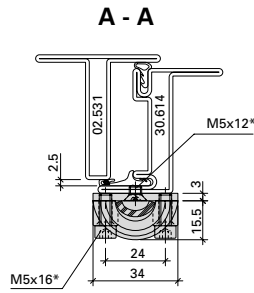
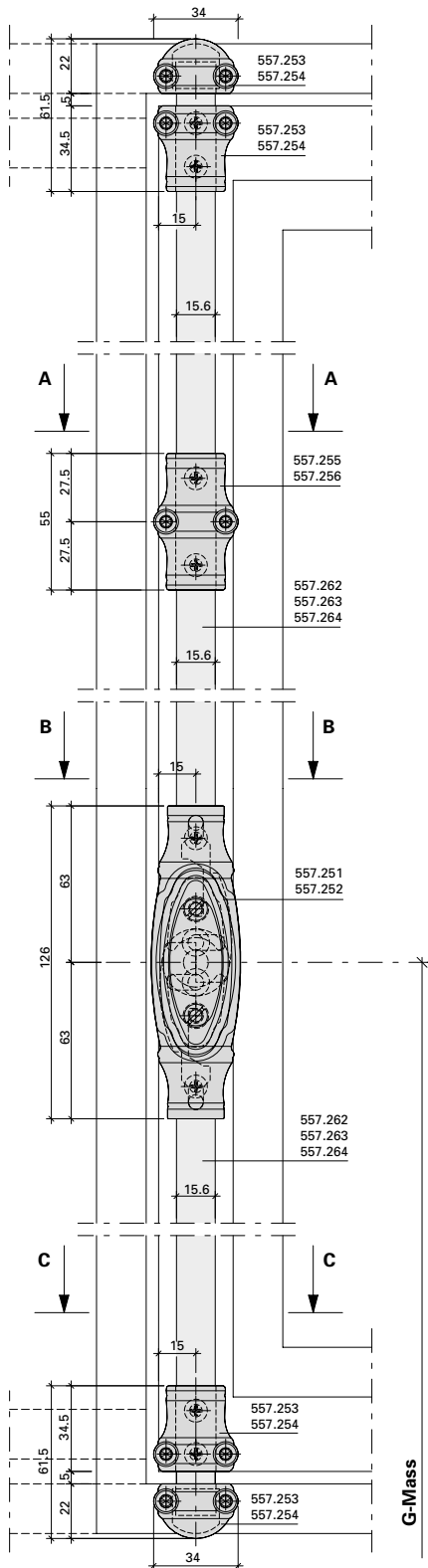

* Schrauben durch Metallbauer zu kürzen.
 * Les vis doivent être raccourcies par le métallier.
 * Screws to be shortened by the metal fabricator.

Aufgesetzter Fensterbeschlag
Fenster einflügelig

Ferrure de fenêtre plaquée
Fenêtre à un vantail

Surface-mounted window fitting
Single-vent window

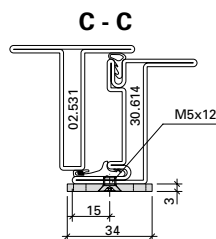
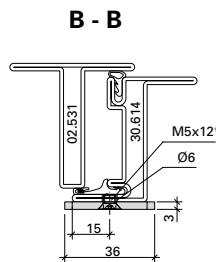
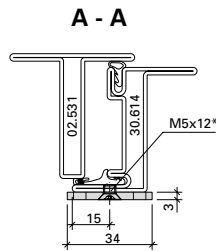
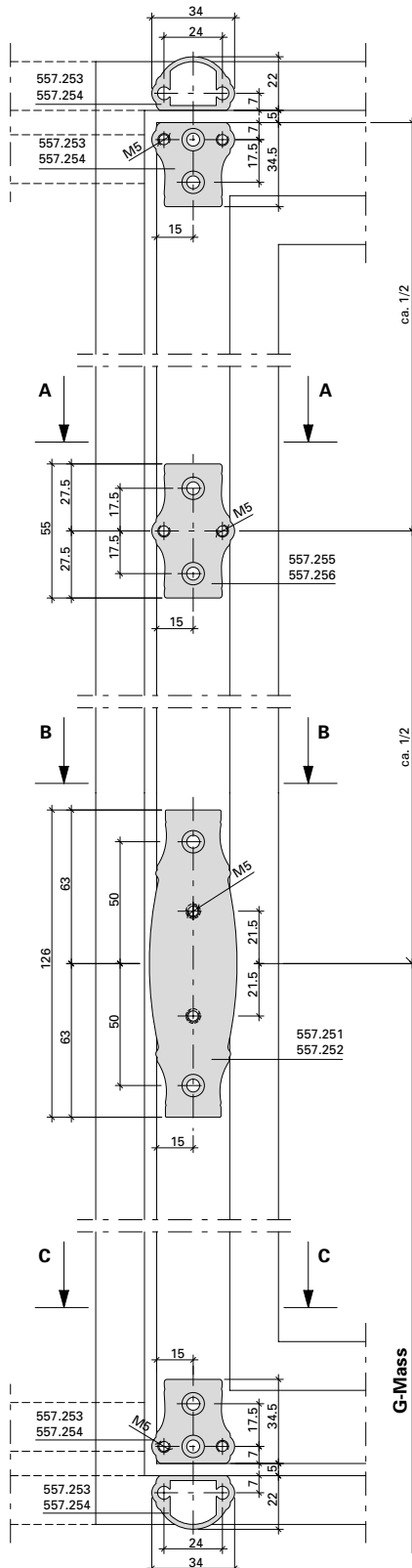

* Schrauben durch Metallbauer zu kürzen.
 * Les vis doivent être raccourcies par le métallier.
 * Screws to be shortened by the metal fabricator.

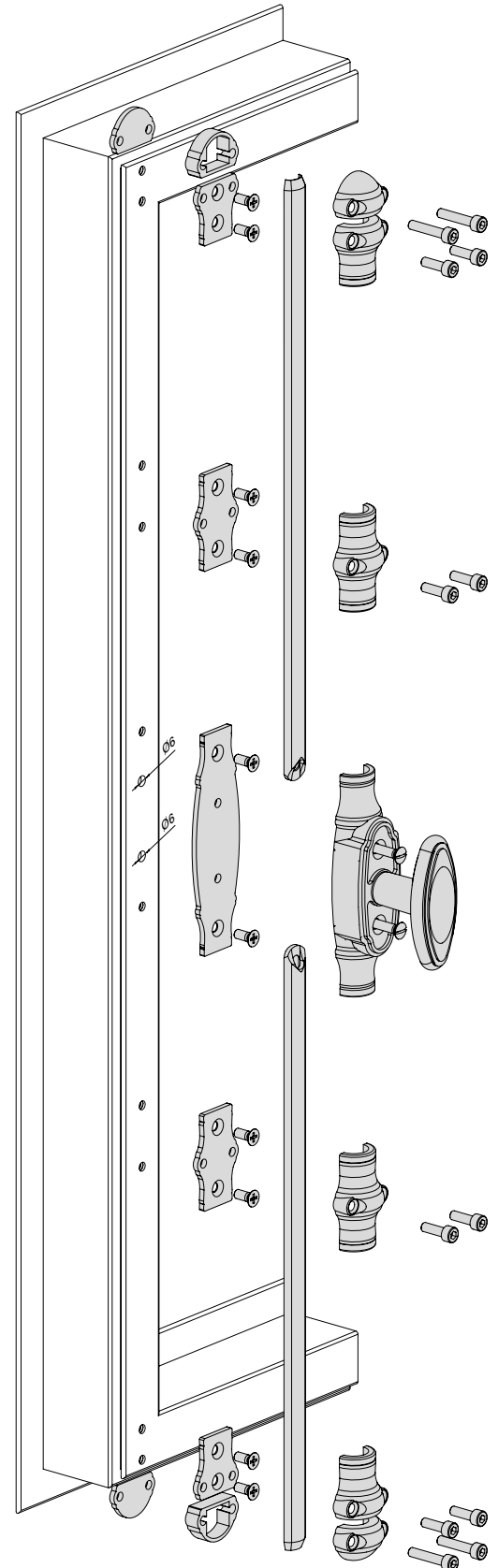

Aufgesetzter Fensterbeschlag
Fenster zweiflügelig

Ferrure de fenêtre plaquée
Fenêtre à deux vantaux

Surface-mounted window fitting
Double-vent window

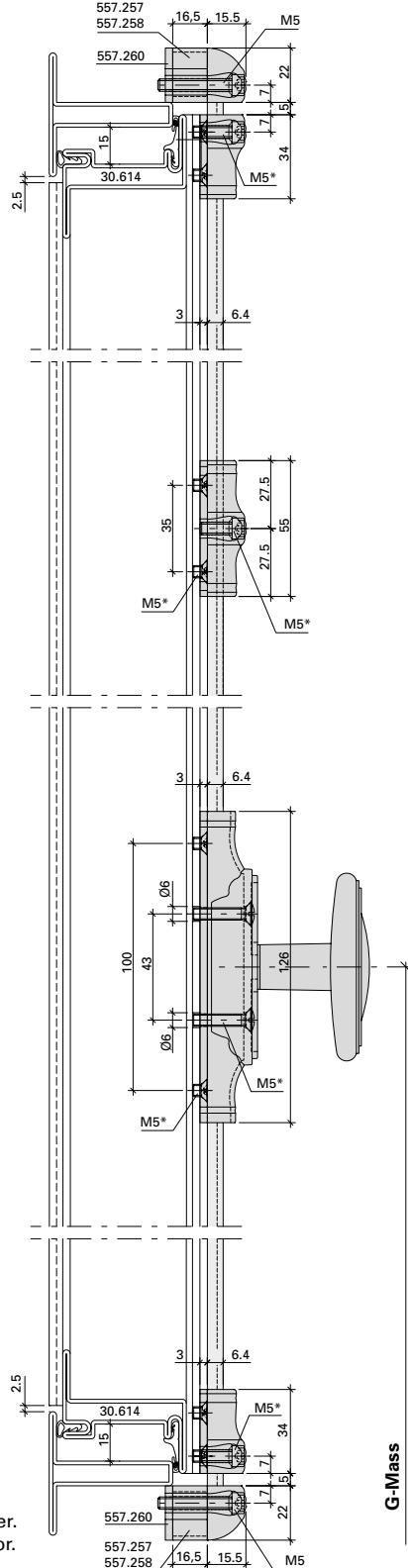
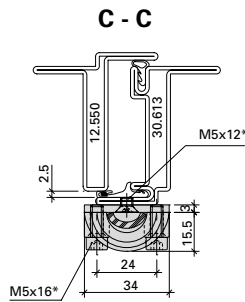
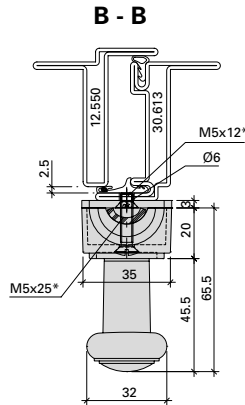
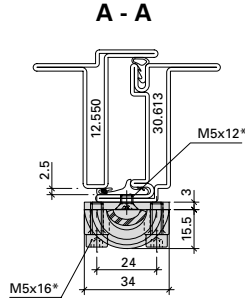
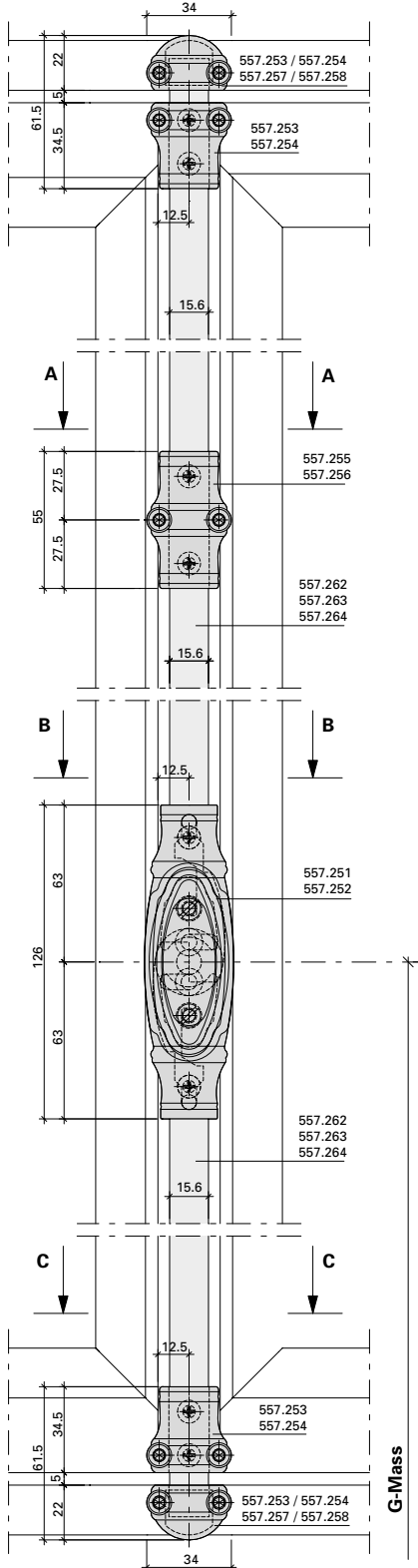

* Schrauben durch Metallbauer zu kürzen.
* Les vis doivent être raccourcies par le métallier.
* Screws to be shortened by the metal fabricator.

Aufgesetzter Fensterbeschlag
Fenster zweiflügelig

Ferrure de fenêtre plaquée
Fenêtre à deux vantaux

Surface-mounted window fitting
Double-vent window

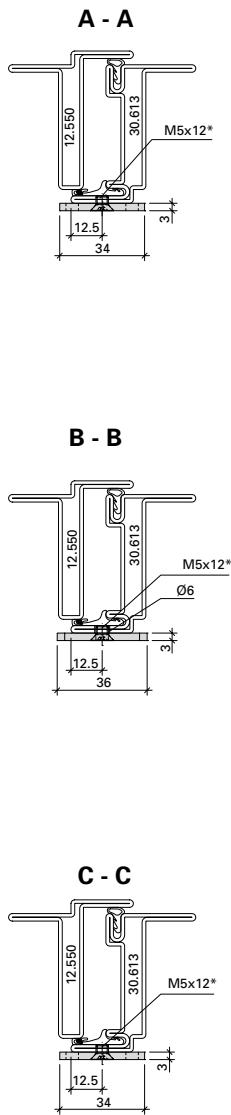
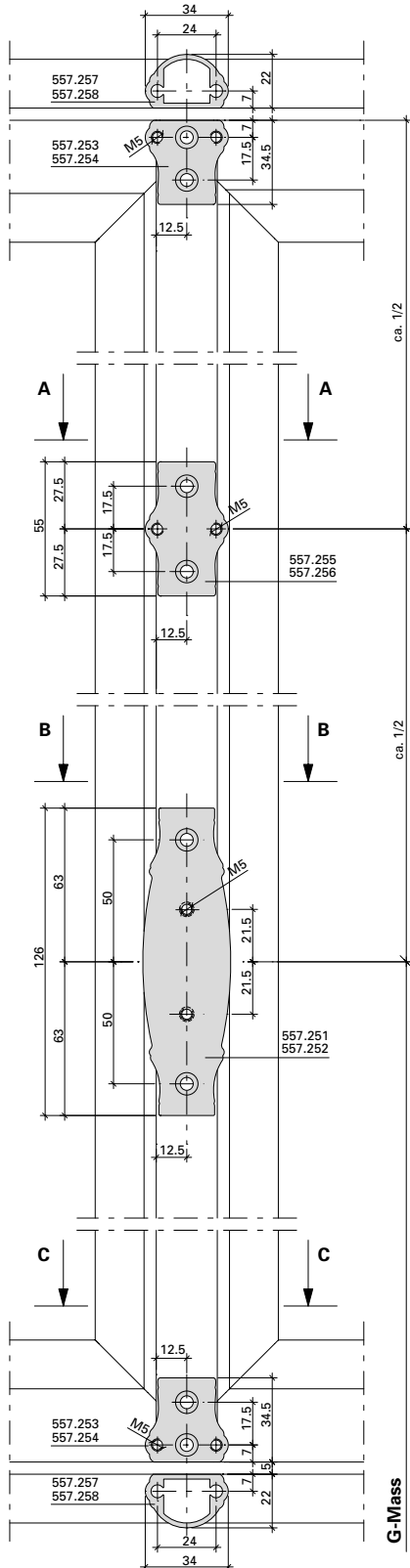

* Schrauben durch Metallbauer zu kürzen.
 * Les vis doivent être raccourcies par le métallier.
 * Screws to be shortened by the metal fabricator.

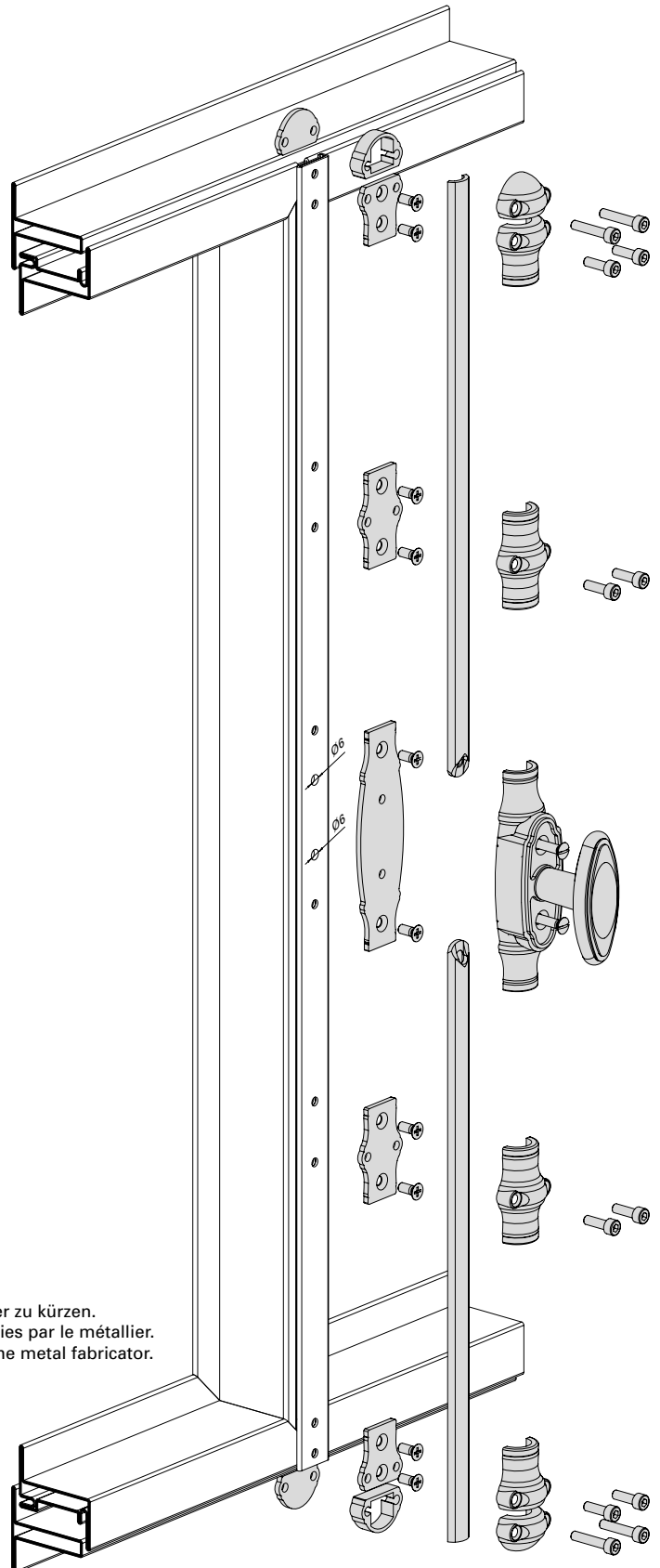

Einbau Schliesstücke 557.253/557.254
 Längenbestimmung
 Verschlussstangen
 Fenster einflügelig

Montage pièces de fermeture
 557.253/557.254
 Détermination de la longueur barre
 de fermeture
 Fenêtre à un vantail

Installation of locking components
 557.253/557.254
 Length specification of closing bars
 Single-vent window

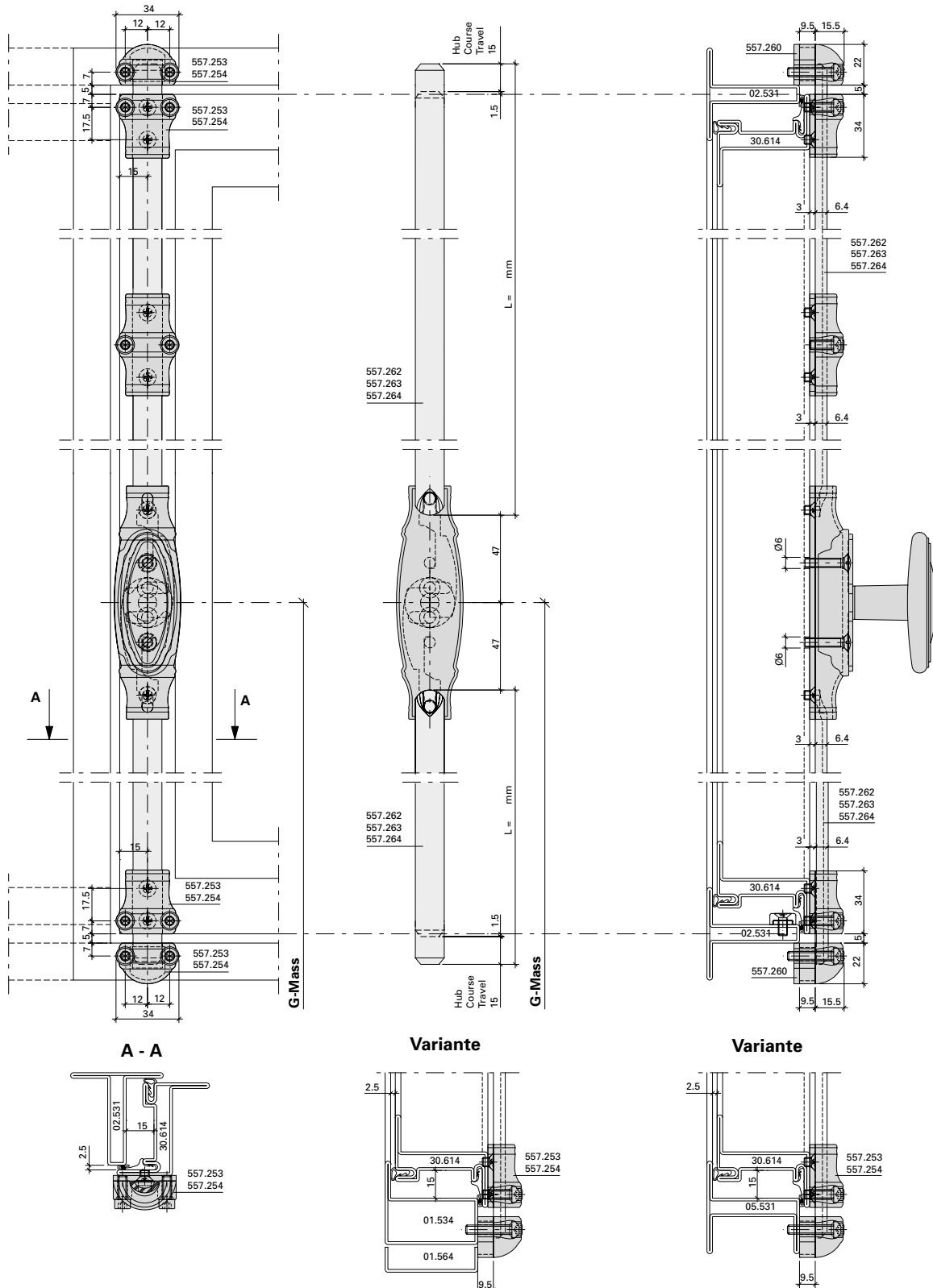

Einbau Spezial-Schliessstück 557.259
Längenbestimmung
Verschlussstangen
Fenster einflügelig

Montage pièce de fermeture spéciale
557.259
Détermination de la longueur barre
de fermeture
Fenêtre à un vantail

Installation of special locking
component 557.259
Length specification of closing bars
Single-vent window

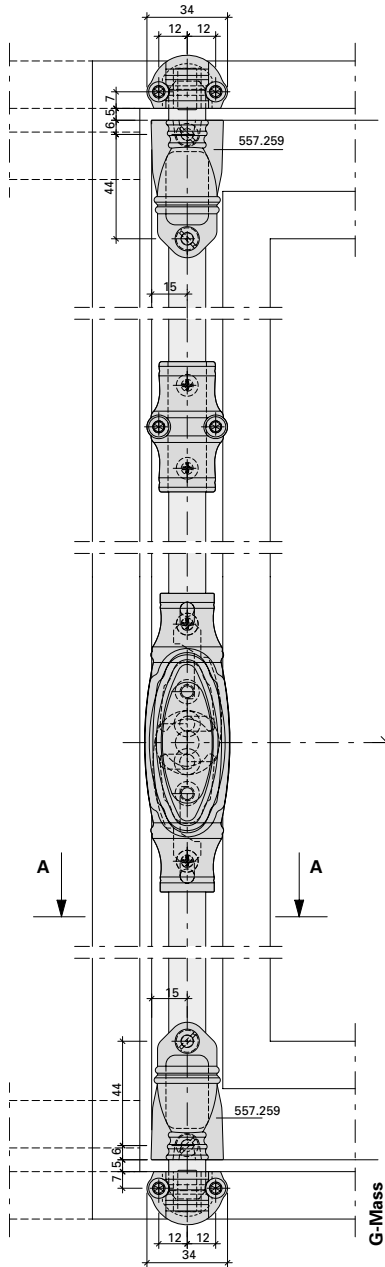

A - A

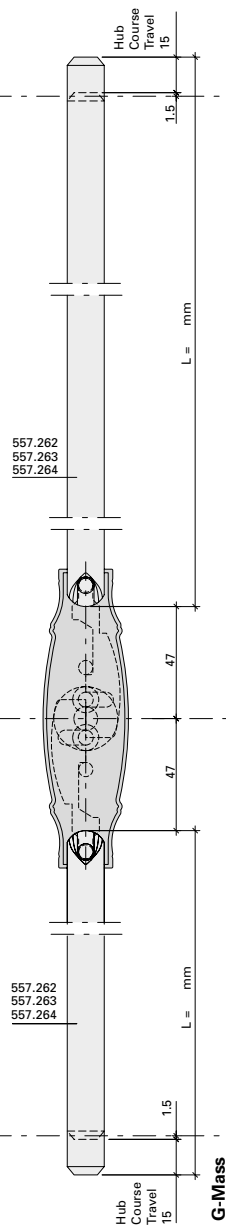
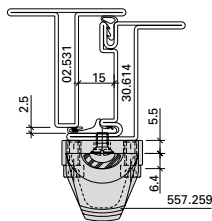

Variante

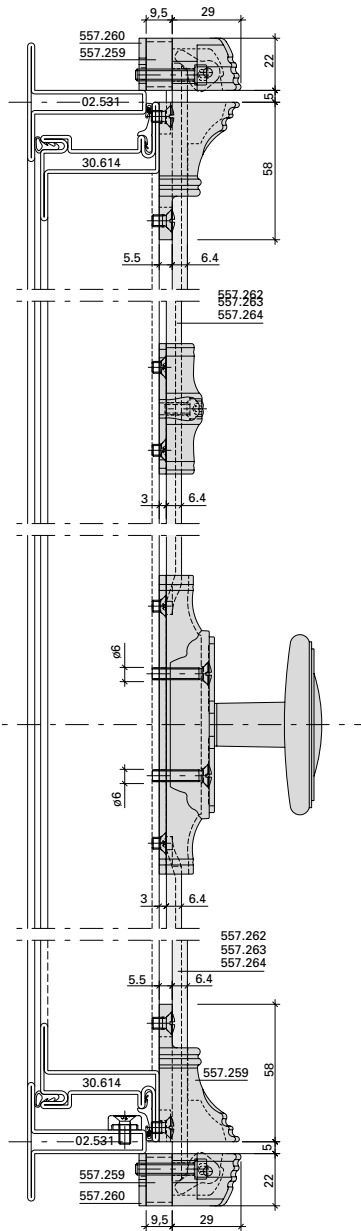
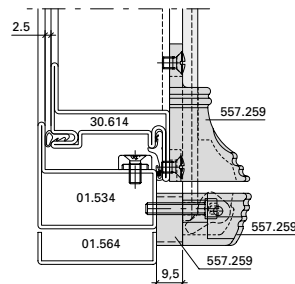

Variante

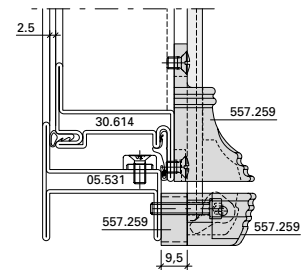

Einbau Spezial-Schliessstück 557.259
Längenbestimmung
Verschlussstangen
Fenster zweiflügelig

Montage pièce de fermeture spéciale
557.259
Détermination de la longueur barre
de fermeture
Fenêtre à deux vantaux

Installation of special locking
component 557.259
Length specification of closing bars
Double-vent window

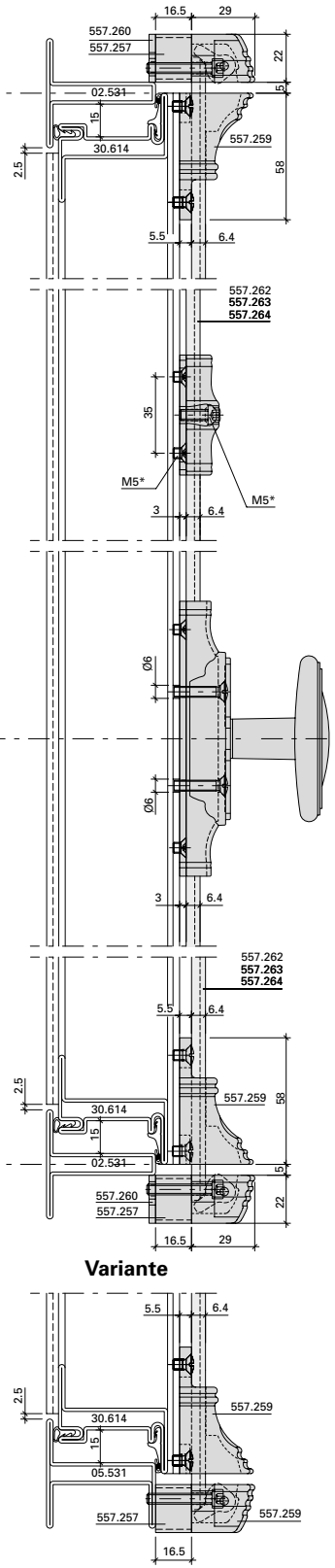
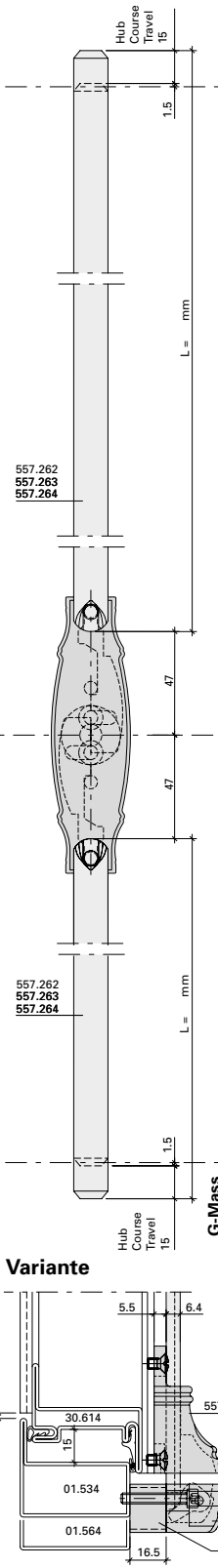
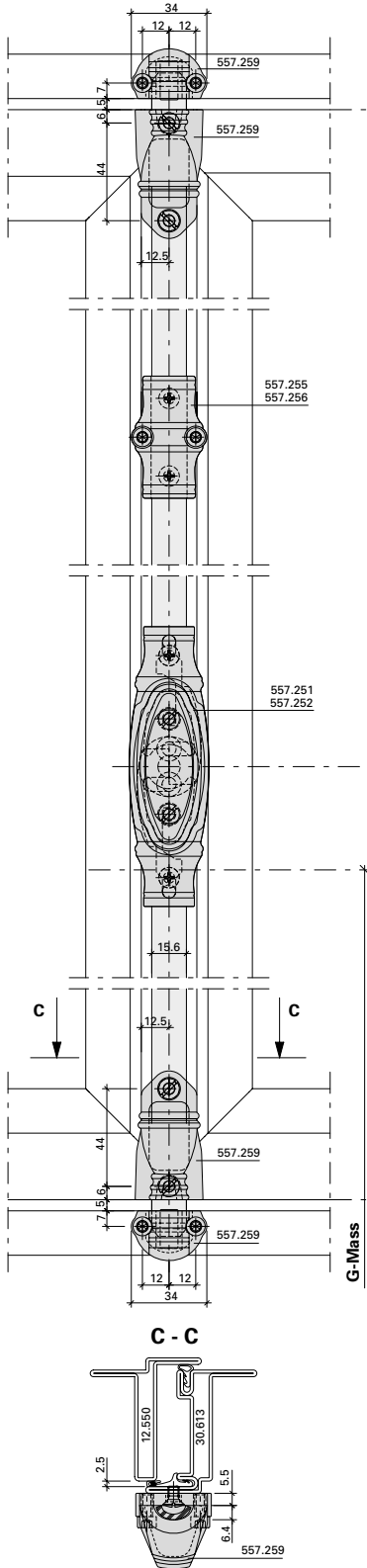

Einbau Anschweislasche 557.260 bei Einsatz von schmalen Rahmen- bzw. Riegelprofilen

Montage languette à souder 557.260 quand de fins profilés de cadre et de traverse sont utilisés

Installation of weld-on fixing bracket 557.260 for use with narrow frame/transom profiles

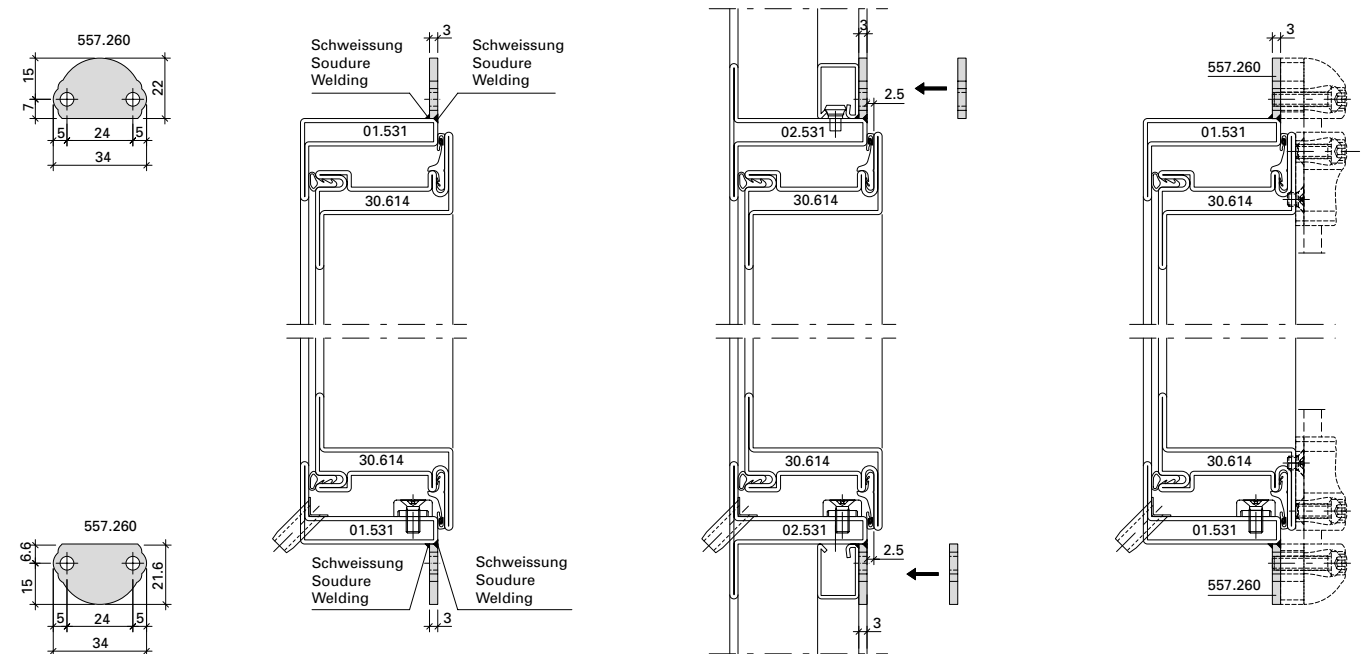

Einbau Anschweislasche 557.261 bei Einsatz von schmalen Rahmen- bzw. Riegelprofilen

Montage languette à souder 557.261 quand de fins profilés de cadre et de traverse sont utilisés

Installation of weld-on fixing bracket 557.261 for use with narrow frame/transom profiles

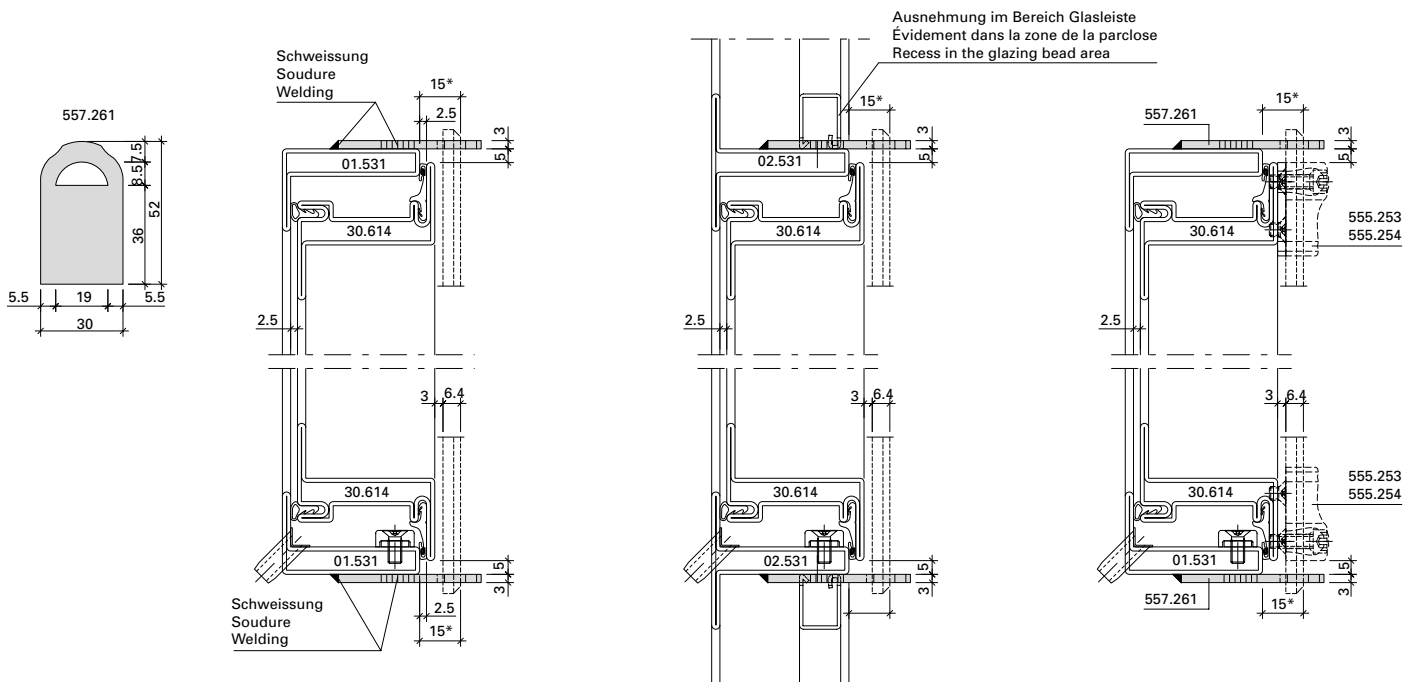

* Mass an Musterelement vorgängig überprüfen

* Contrôler d'abord la cote sur un échantillon

* Check dimension on sample unit in advance

Verdeckt liegender Fensterbeschlag

Ferrure de fenêtre non apparente

Concealed window fitting

Definition Symbole

Définition des symboles

Definition of symbols

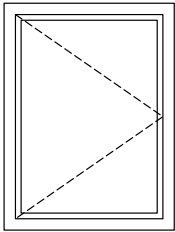

Dreh-Fenster einflügelig
 nach innen öffnend

Fenêtre à la française
 à un vantail
 ouvrant vers l'intérieur

Single-vent side-hung window
 inward opening

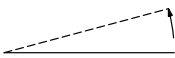

Definition G-Mass und FFH/FFB

Définition de la mesure G et FFH/FFB

Definition of G measurement and
 FFH/FFB

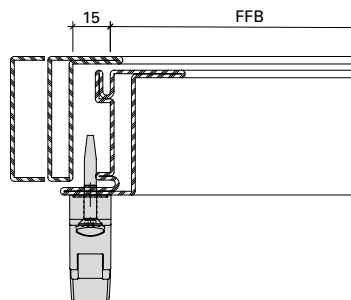
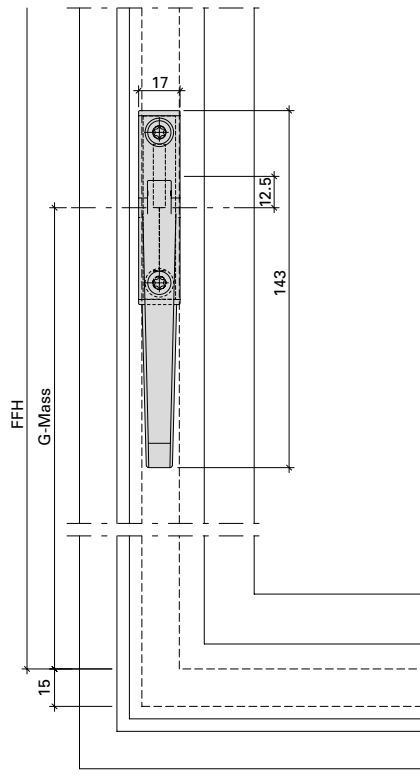
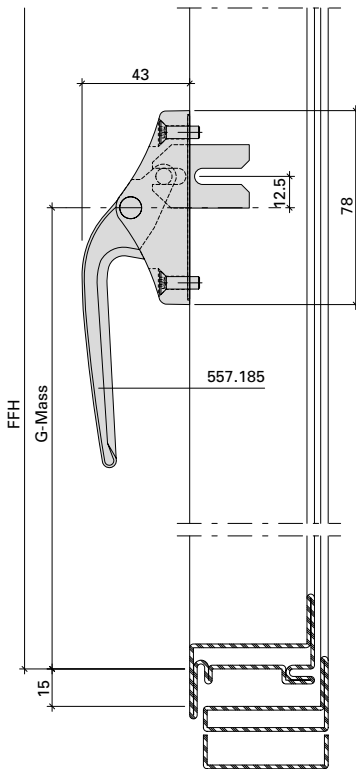

Verdeckt liegender Fensterbeschlag

Ferrure de fenêtre non apparente

Concealed window fitting

Definition Symbole

Définition des symboles

Definition of symbols

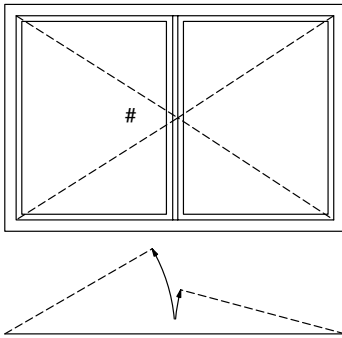

Dreh-Fenster zweiflügelig
 nach innen öffnend

Fenêtre à la française
 à deux vantaux
 ouvrant vers l'intérieur

Double-vent side-hung window
 inward opening

Definition G-Mass und FFH/FFB

Définition de la mesure G et FFH/FFB

Definition of G measurement and FFH/FFB

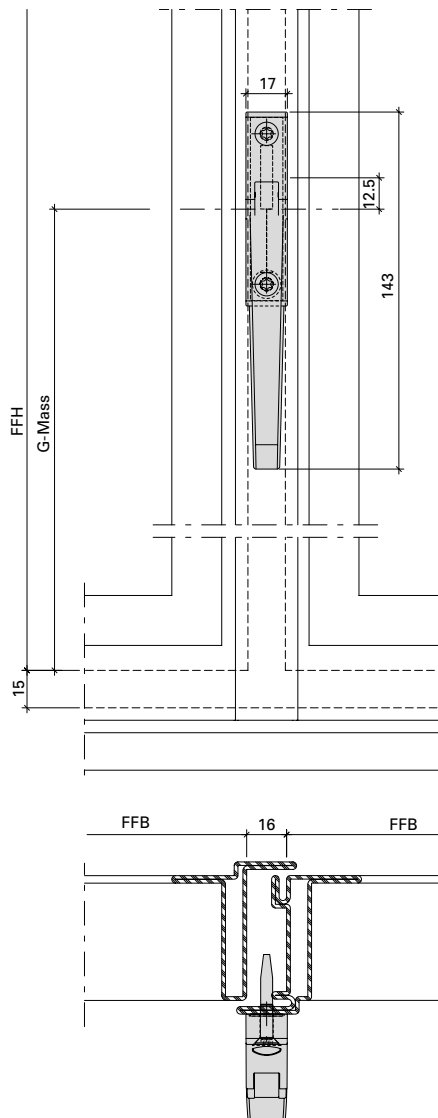
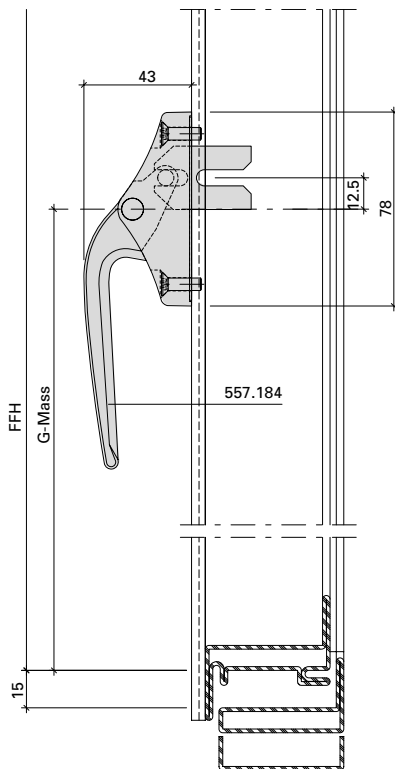

Verdeckt liegender Fensterbeschlag
 Anordnung Verriegelungspunkte
 Fenster einflügelig
 nach innen öffnend

Ferrure de fenêtre non apparente
 Disposition des points de verrouillage
 Fenêtre à un vantail
 ouvrant vers l'intérieur

Concealed window fitting
 Arrangement of locking points
 Single-vent window
 inward opening

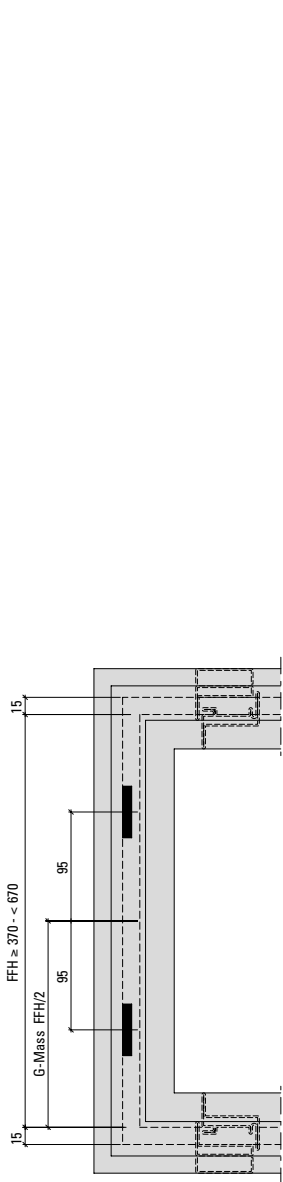

FFH 370 - 670 mm
 G-Mass FFH/2

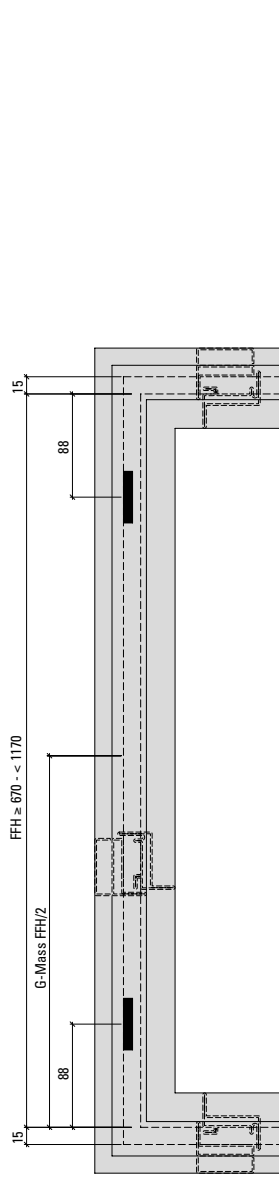

FFH 670 - 1170 mm
 G-Mass FFH/2

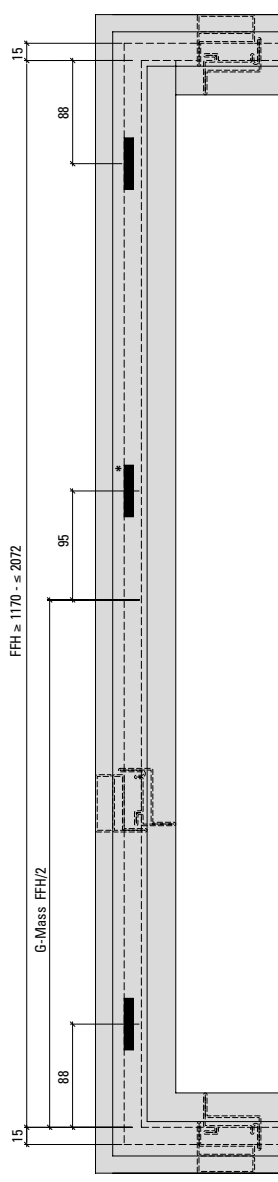

FFH 1170 - 2072 mm
 G-Mass FFH/2

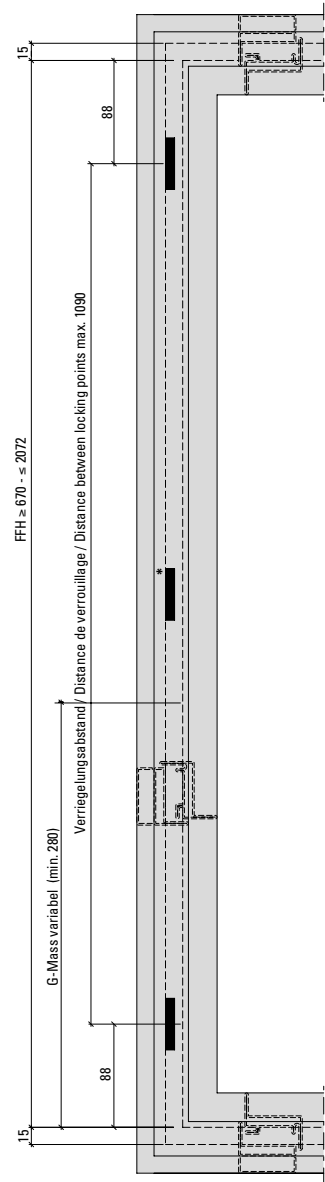

FFH 670 - 2072 mm
 freies G-Mass (min. 185 mm)
 Mesure G libre (min. 185 mm)
 unspecified G measurement
 (min. 185 mm)

	FFH		
	370 - 669 mm	670 - 1169 mm	1170 - 2072 mm
	G = (FFH/2)		
557.291	-	1x	1x
557.290	1x	1x	1x
557.291	-	1x	1x
557.292	1x	1x	1x
557.293	1x(2)	1x(2)	1x(3)

- * zusätzlicher Verriegelungspunkt > 1090 mm
- * point de verrouillage supplémentaire > 1090 mm
- * additional locking point > 1090 mm

Verdeckt liegender Fensterbeschlag
 Anordnung Verriegelungspunkte
 Fenster zweiflügelig
 nach innen öffnend

Ferrure de fenêtre non apparente
 Disposition des points de verrouillage
 Fenêtre à deux vantaux
 ouvrant vers l'intérieur

Concealed window fitting
 Arrangement of locking points
 Double-vent window
 inward opening

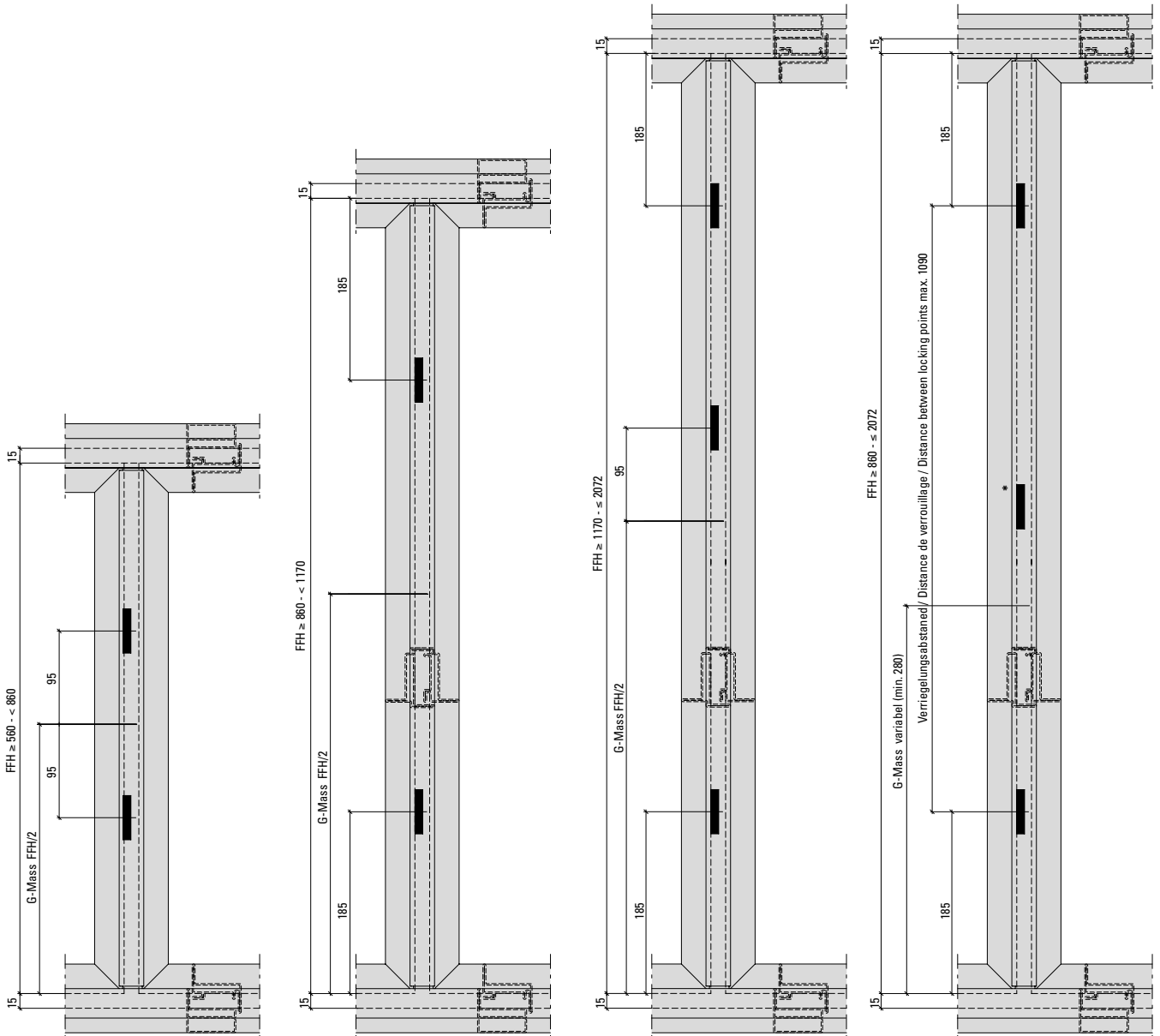

FFH 560 - 860 mm
 G-Mass FFH/2

FFH 860 - 1170 mm
 G-Mass FFH/2

FFH 1170 - 2072 mm
 G-Mass FFH/2

FFH 860 - 2072 mm
 freies G-Mass (min. 280 mm)
 Mesure G libre (min. 280 mm)
 unspecified G measurement
 (min. 280 mm)

	FFH		
	370 - 669 mm	670 - 1169 mm	1170 - 2072 mm
	G = (FFH/2)		
557.291	–	1x	1x
557.290	1x	1x	1x
557.291	–	1x	1x
557.186	1x	1x	1x
557.293	1x(2)	1x(2)	1x(3)

- * zusätzlicher Verriegelungspunkt > 1090 mm
- * point de verrouillage supplémentaire > 1090 mm
- * additional locking point > 1090 mm

Verdeckt liegender Fensterbeschlag
 Fenster einflügelig
 Verriegelung mittig

Ferrure de fenêtre non apparente
 Fenêtre à un vantail
 Verrouillage centre

Concealed window fitting
 Single-vent window
 Locking point (centre)

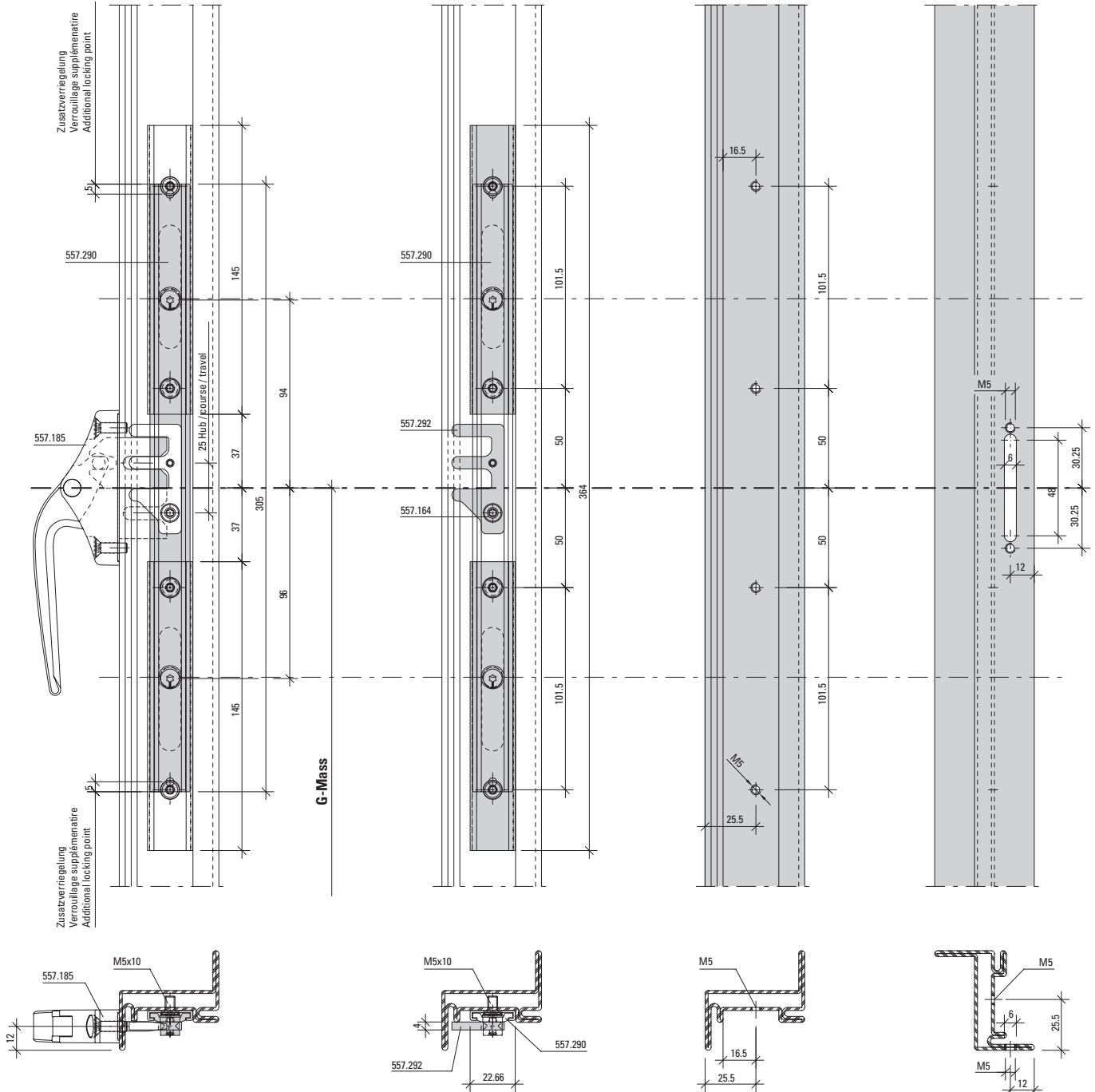

- * Bei Falzlufte 15 mm FB = min. 400 mm
 Bei Falzbreite < 400 mm: Falzlufte entsprechend vergrössern und Schliessblech-Unterlagen 557.307 einsetzen
- * Pour jeu de feuillure 15 mm FB = min. 400 mm
 Pour largeur de feuillure < 400 mm: agrandir le jeu de feuillure en conséquence et mettre les butées de gâche 557.307 en place
- * For rebate space of 15 mm FB = min. 400 mm
 If rebate width < 400 mm: increase rebate space accordingly and insert strike plate supports 557.307

**Verdeckt liegender Fensterbeschlag
Fenster einflügelig
Verriegelung mittig**

**Ferrure de fenêtre non apparente
Fenêtre à un vantail
Verrouillage centre**

**Concealed window fitting
Single-vent window
Locking point (centre)**

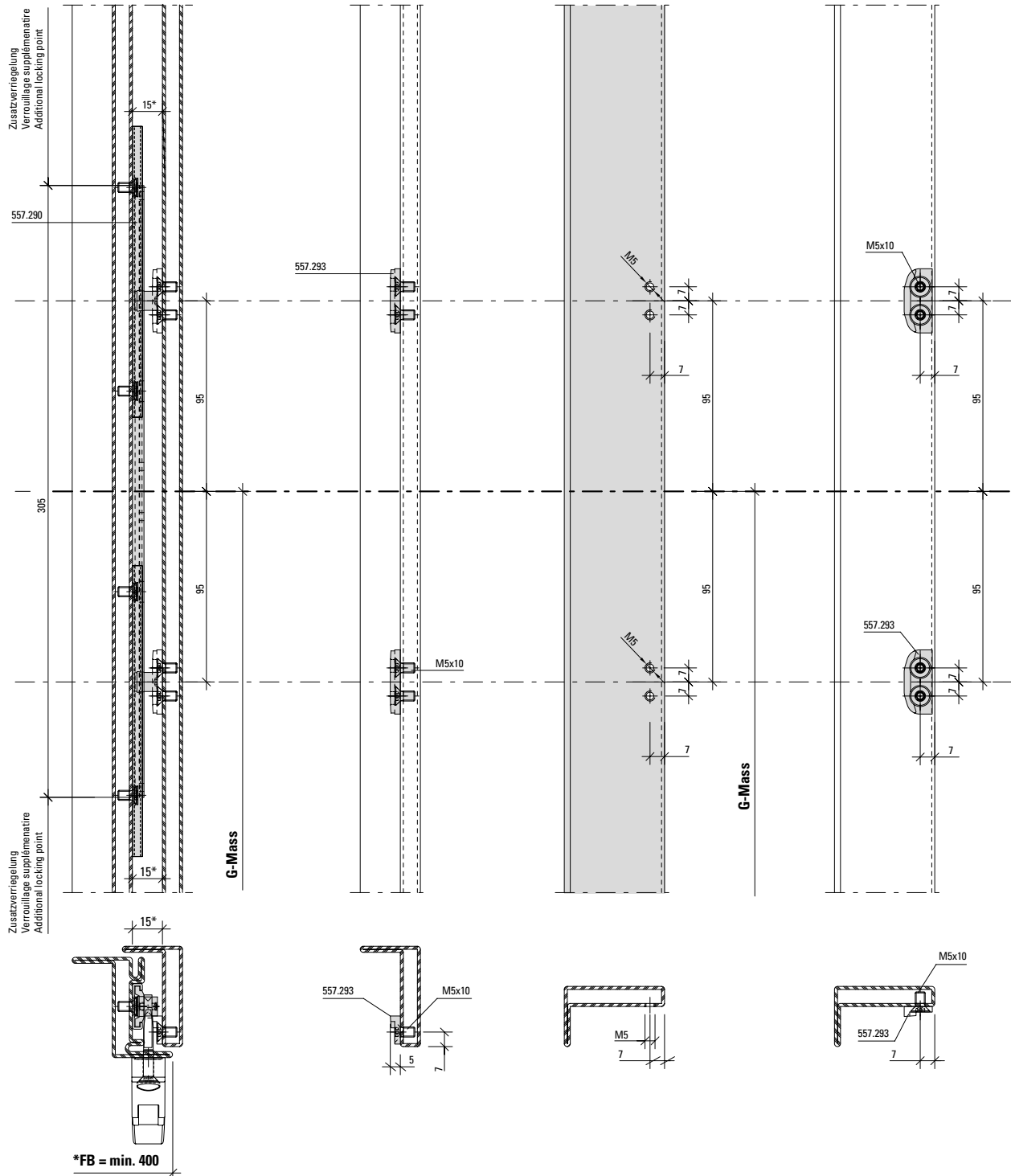

Verdeckt liegender Fensterbeschlag
Fenster einflügelig
Zusatzverriegelung oben

Ferrure de fenêtre non apparente
Fenêtre à un vantail
Verrouillage supplémentaire en haut

Concealed window fitting
Single-vent window
Additional locking point (top)

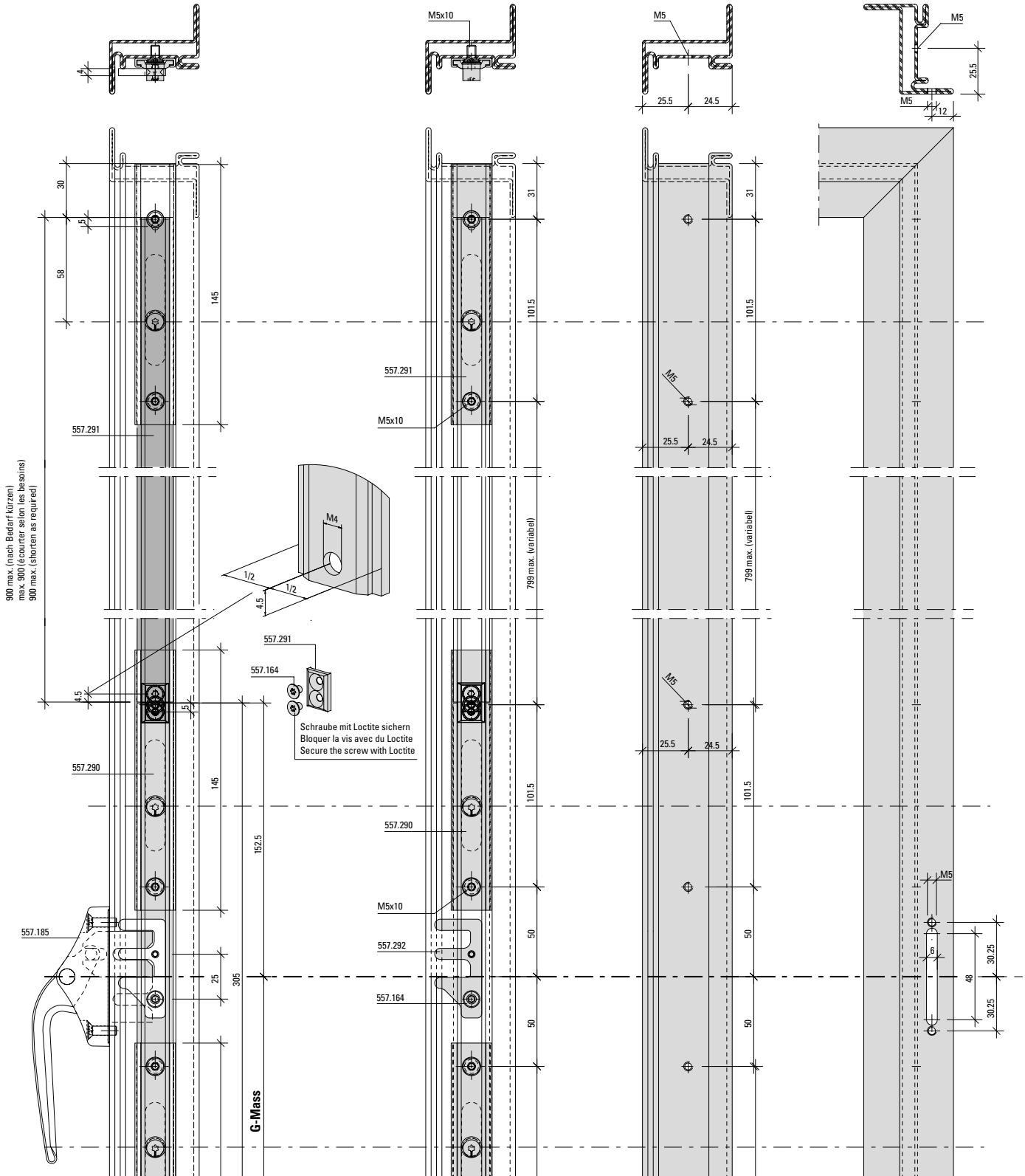

Verdeckt liegender Fensterbeschlag
 Fenster einflügelig
 Zusatzverriegelung oben

Ferrure de fenêtre non apparente
 Fenêtre à un vantail
 Verrouillage supplémentaire en haut

Concealed window fitting
 Single-vent window
 Additional locking point (top)

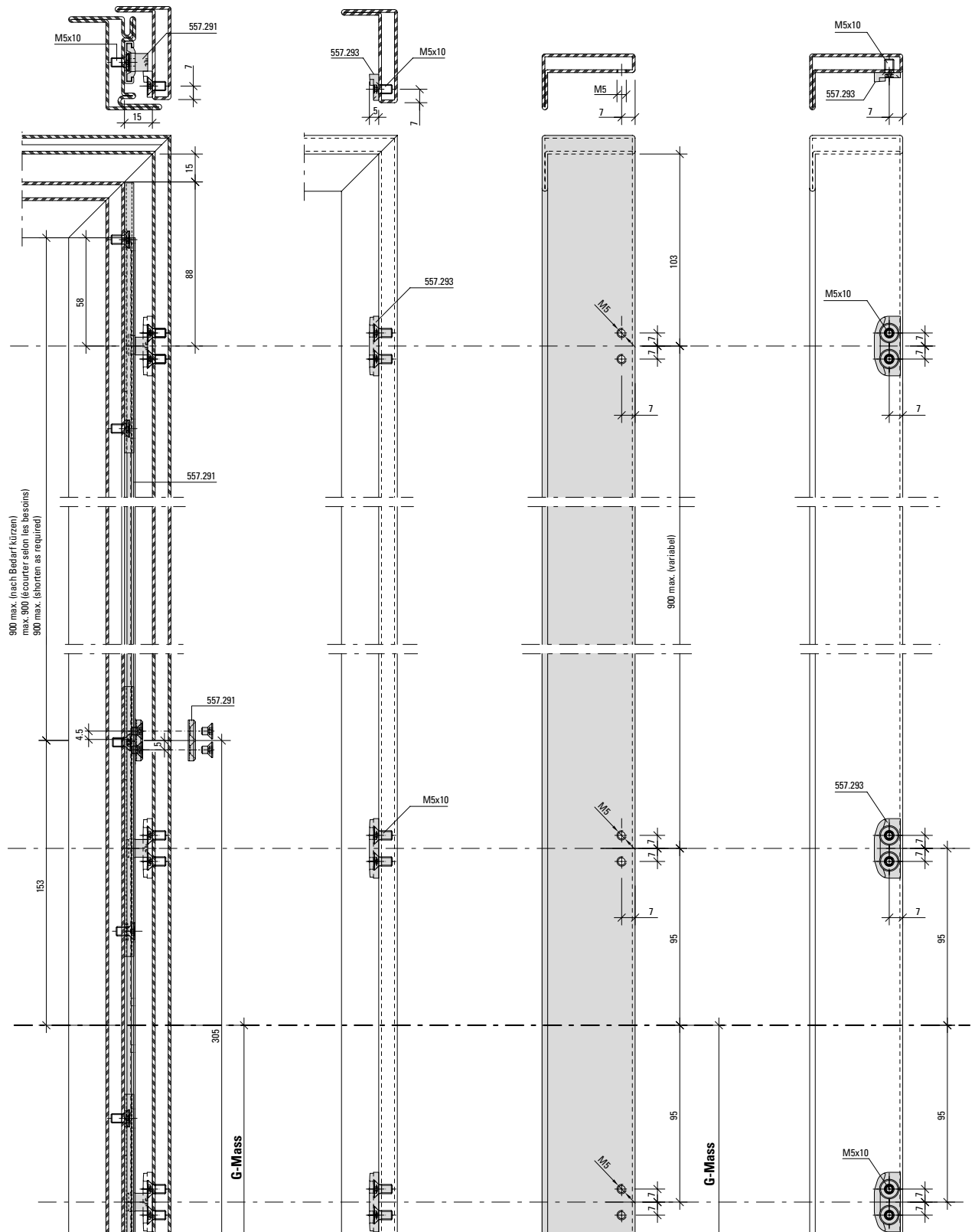

Verdeckt liegender Fensterbeschlag
Fenster einflügelig
Zusatzverriegelung unten

Ferrure de fenêtre non apparente
Fenêtre à un vantail
Verrouillage supplémentaire en bas

Concealed window fitting
Single-vent window
Additional locking point (bottom)

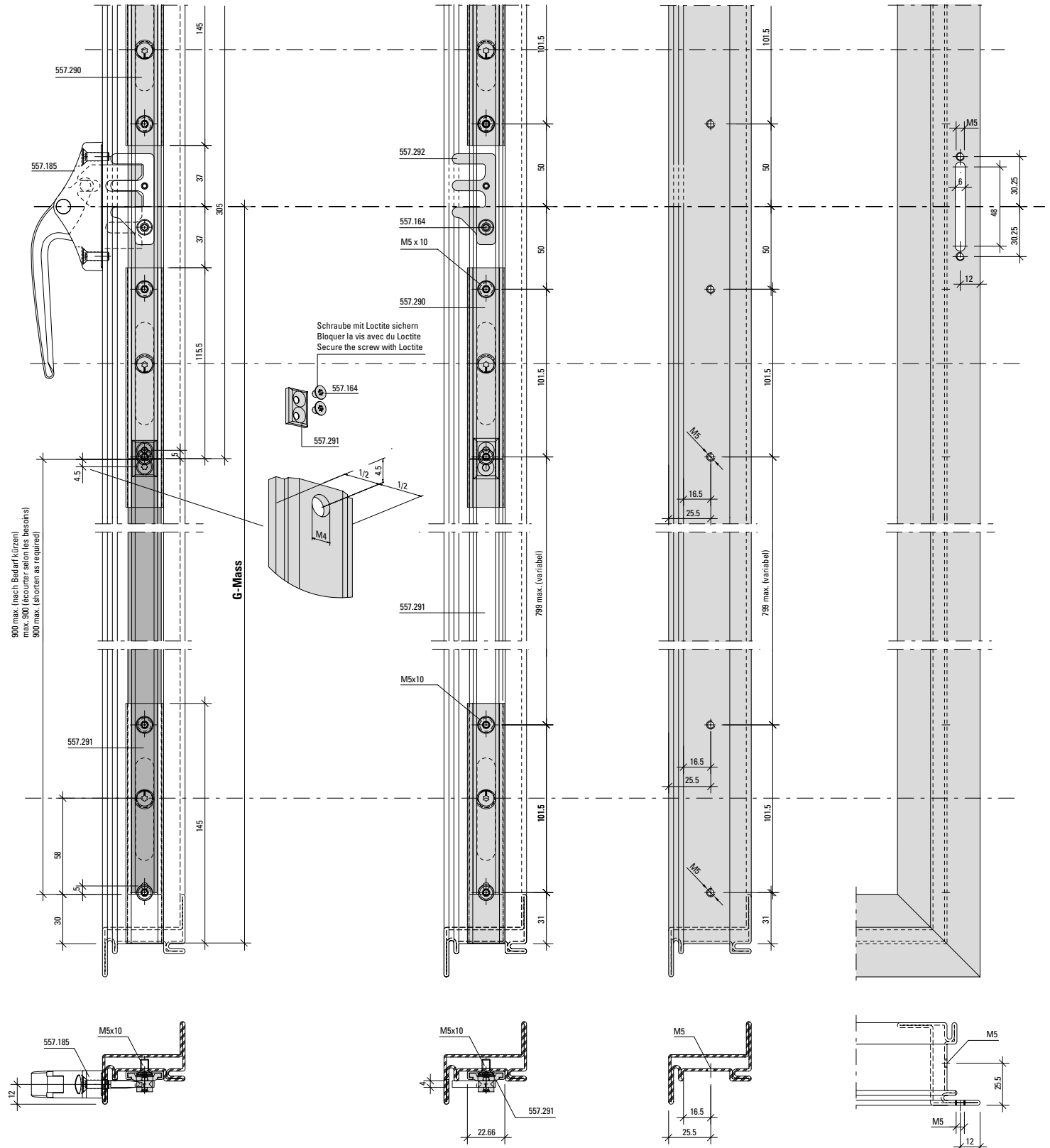

Verdeckt liegender Fensterbeschlag
Fenster einflügelig
Zusatzverriegelung unten

Ferrure de fenêtre non apparente
Fenêtre à un vantail
Verrouillage supplémentaire en bas

Concealed window fitting
Single-vent window
Additional locking point (bottom)

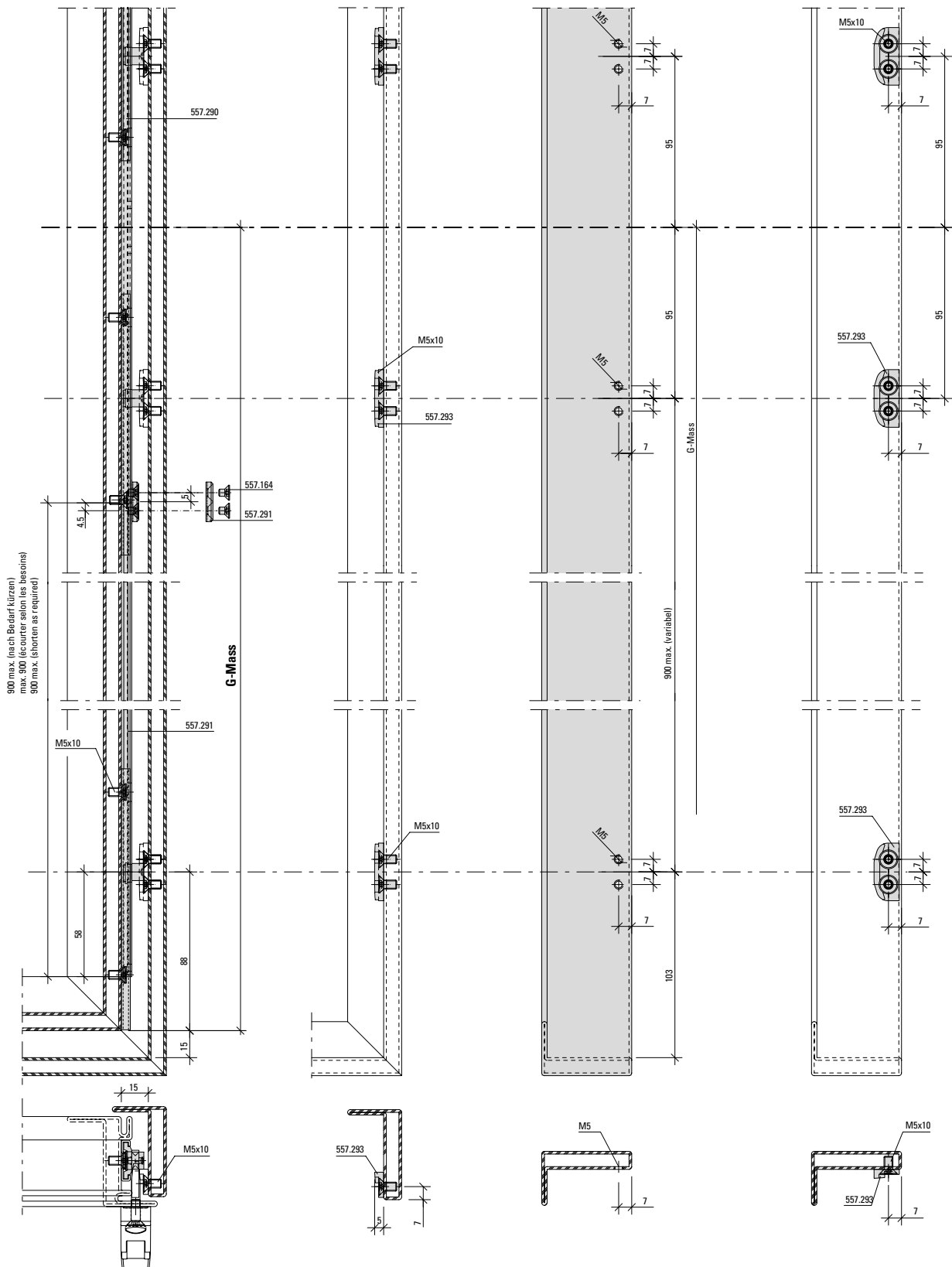

Verdeckt liegender Fensterbeschlag
 Fenster zweiflügelig
 Verriegelung mittig

Ferrure de fenêtre non apparente
 Fenêtre à deux vantaux
 Verrouillage centre

Concealed window fitting
 Double-vent window
 Locking point (centre)

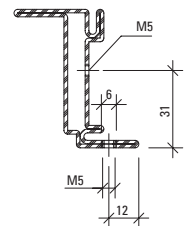
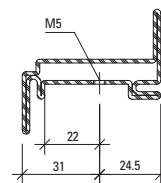
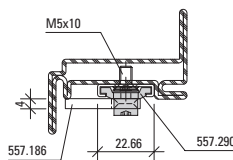
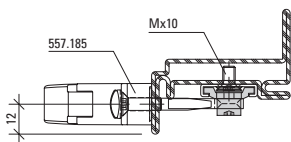
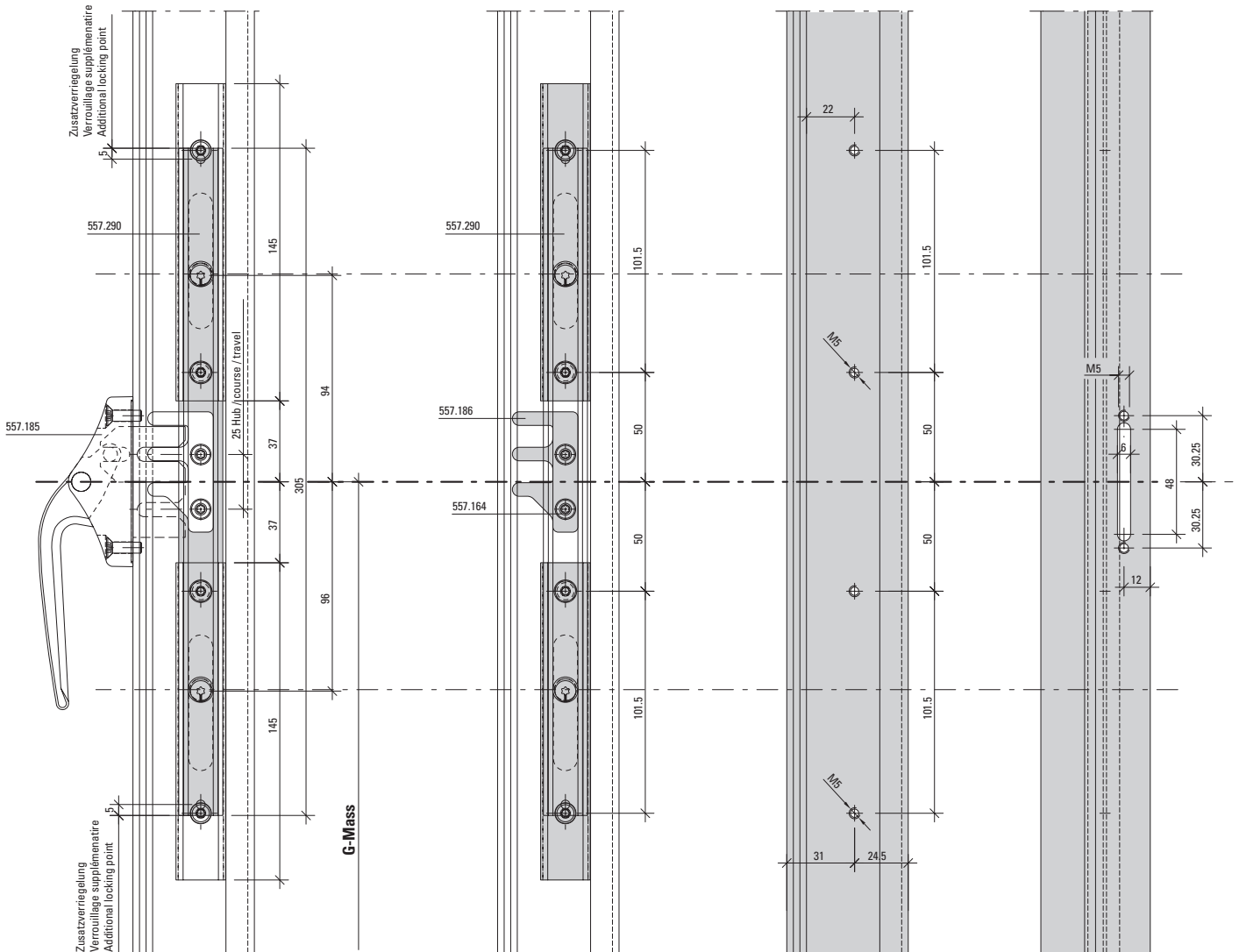

- * Bei Falzlufth 16 mm FB = min. 600 mm
 Bei Falzbreite < 600 mm: Falzlufth entsprechend vergrössern und Schliessblech-Unterlagen 557.307 einsetzen
- * Pour jeu de feuillure 16 mm FB = min. 600 mm
 Pour largeur de feuillure < 600 mm: agrandir le jeu de feuillure en conséquence et mettre les butées de gâche 557.307 en place
- * For rebate space of 16 mm FB = min. 600 mm
 If rebate width < 600 mm: increase rebate space accordingly and insert strike plate supports 557.307

Verdeckt liegender Fensterbeschlag
Fenster zweiflügelig
Verriegelung mittig

Ferrure de fenêtre non apparente
Fenêtre à deux vantaux
Verrouillage centre

Concealed window fitting
Double-vent window
Locking point (centre)

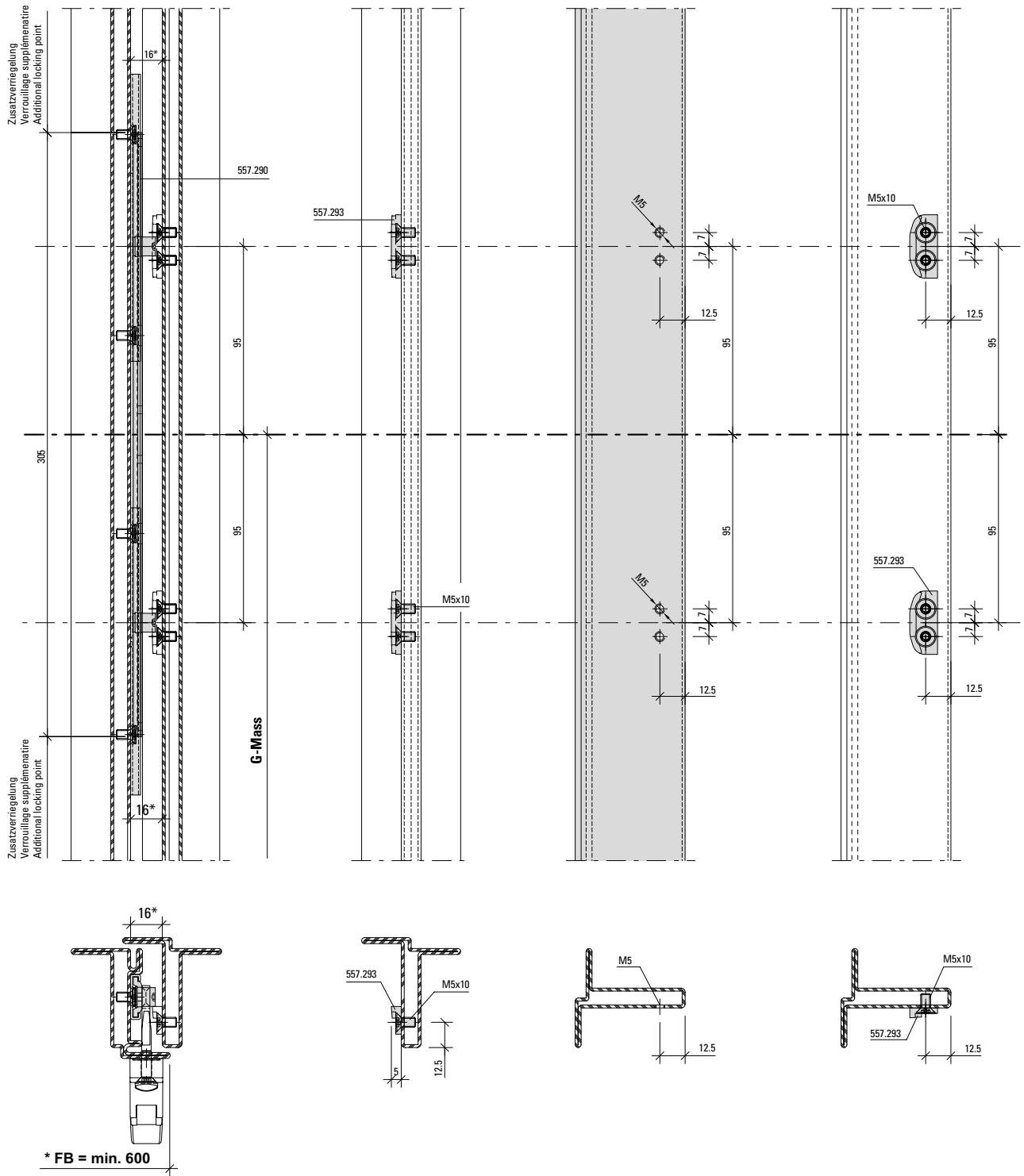

Verdeckt liegender Fensterbeschlag
 Fenster zweiflügelig
 Einbau Kantenriegel
 557.192/557.139

Ferrure de fenêtre non apparente
 Fenêtre à deux vantaux
 Montage verrou à bascule
 557.192/557.139

Concealed window fitting
 Double-vent window
 Installation flush bolt
 557.192/557.139

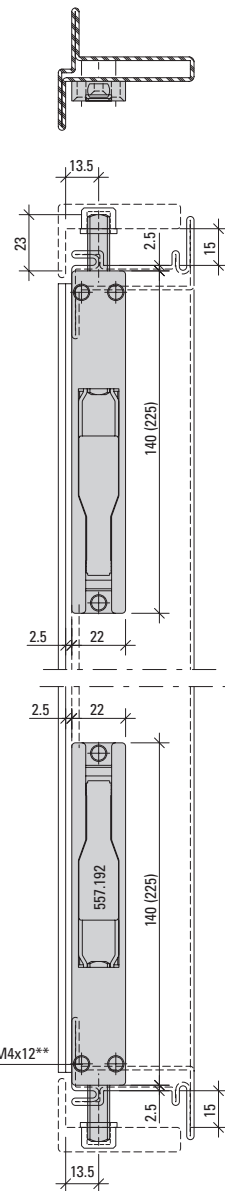
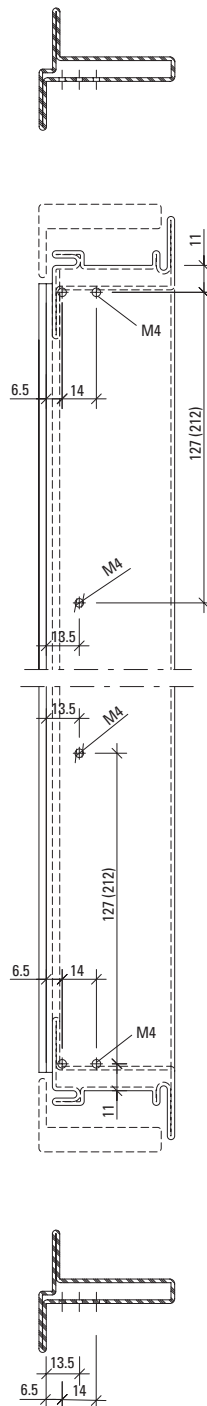
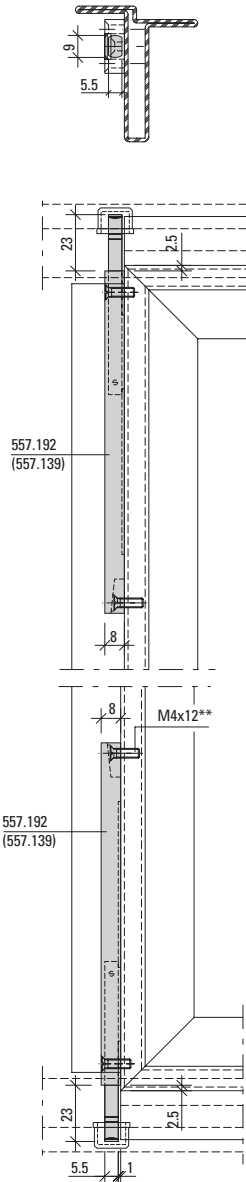
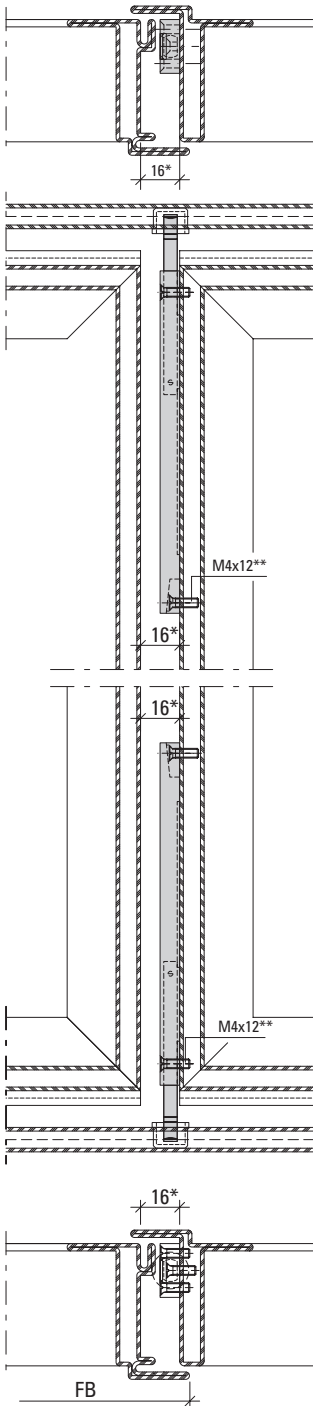

* Bei Falzluft 16 mm FB = min. 600 mm
 Bei Falzbreite < 600 mm: Falzluft entsprechend vergrößern und Schliessblech-Unterlagen 557.307 einsetzen
 * Pour jeu de feuillure 16 mm FB = min. 600 mm
 Pour largeur de feuillure < 600 mm: agrandir le jeu de feuillure en conséquence et mettre les butées de gâche 557.307 en place
 * For rebate space of 16 mm FB = min. 600 mm
 If rebate width < 600 mm: increase rebate space accordingly and insert strike plate supports 557.307

** Bestehende Bohrungen für M4-Schrauben aufbohren und ansenken
 ** Percer les trous existants pour les vis M4 et chanfreiner
 ** Drill out and countersink existing holes for M4 screws

Verdeckt liegender Fensterbeschlag
Fenster zweiflügelig
Einbau Schliesshülse für
Kantenriegel 557.192 / 557.139

Ferrure de fenêtre non apparente
Fenêtre à deux vantaux
Montage gâche pour verrou à
bascule 557.192 / 557.139

Concealed window fitting
Double-vent window
Installation locking sleeve for flush
bolt 557.192 / 557.139

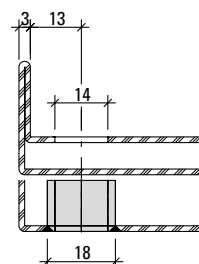
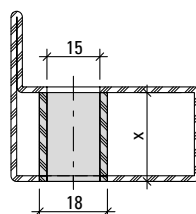
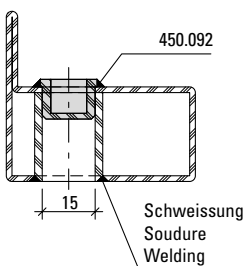
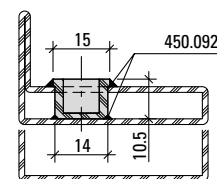
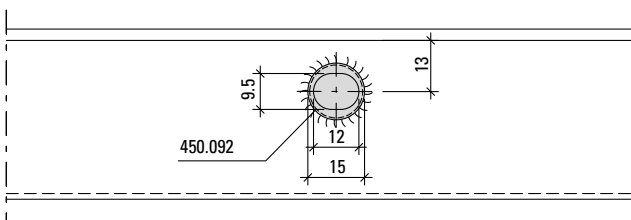
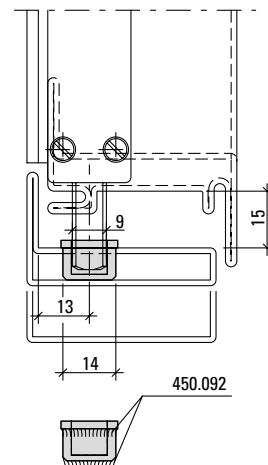
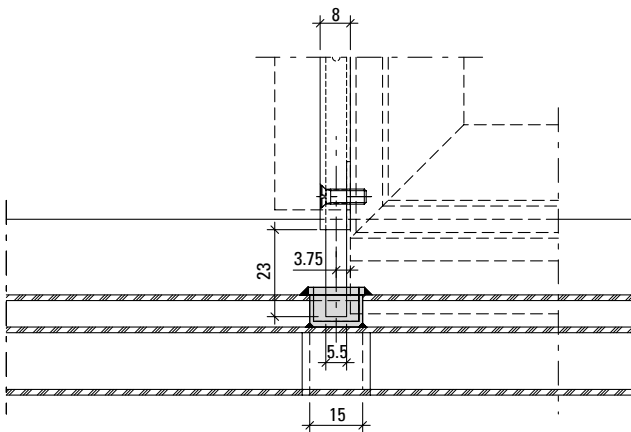
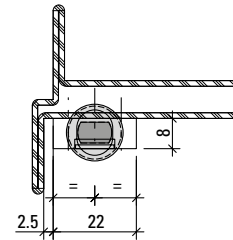
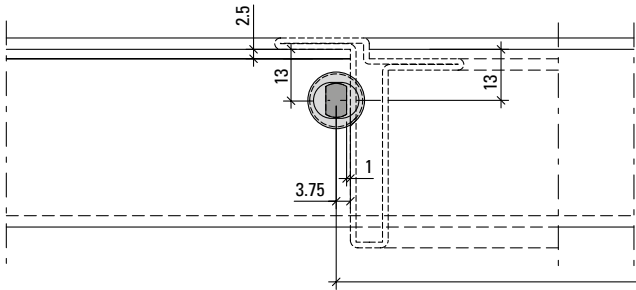

Verdeckt liegender Fensterbeschlag
Fenster zweiflügelig
Verriegelung oben (Variante) 557.172
Gangflügel

Ferrure de fenêtre non apparente
Fenêtre à deux vantaux
Verrouillage en haut (variante) 557.172
Vantail de service

Concealed window fitting
Double-vent window
Top lock (alternative) 557.172
Access leaf

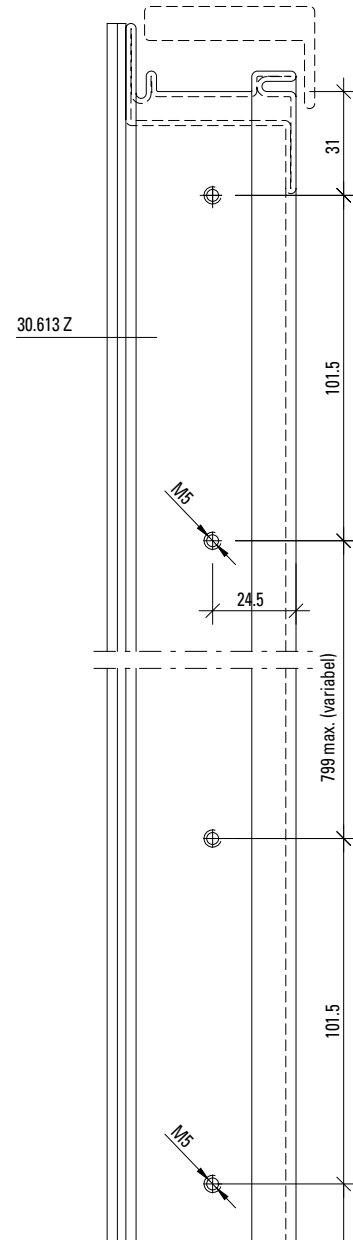
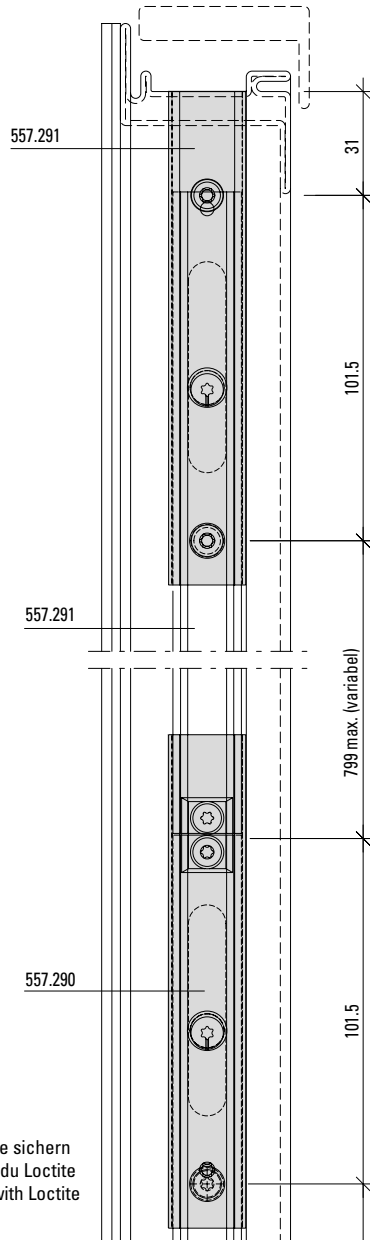
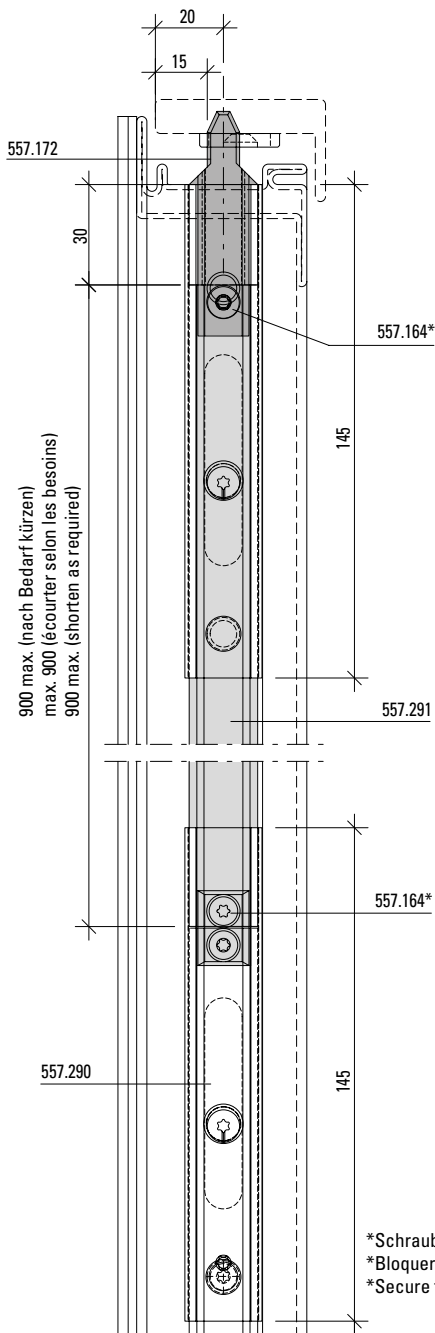
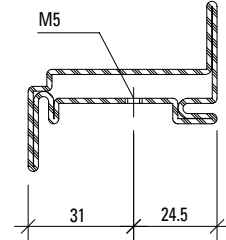
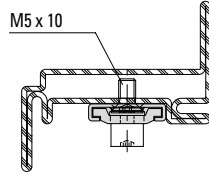
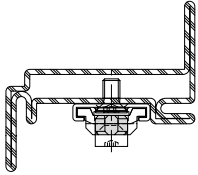

*Schraube mit Loctite sichern
 *Bloquer la vis avec du Loctite
 *Secure the screw with Loctite

Verdeckt liegender Fensterbeschlag
Fenster zweiflügelig
Verriegelung oben (Variante) 557.172
Gangflügel

Ferrure de fenêtre non apparente
Fenêtre à deux vantaux
Verrouillage en haut (variante) 557.172
Vantail de service

Concealed window fitting
Double-vent window
Top lock (alternative) 557.172
Access leaf

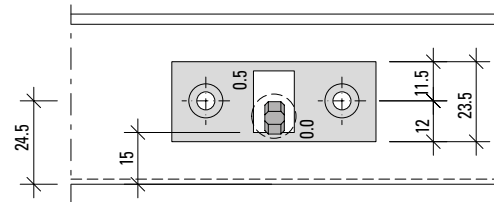
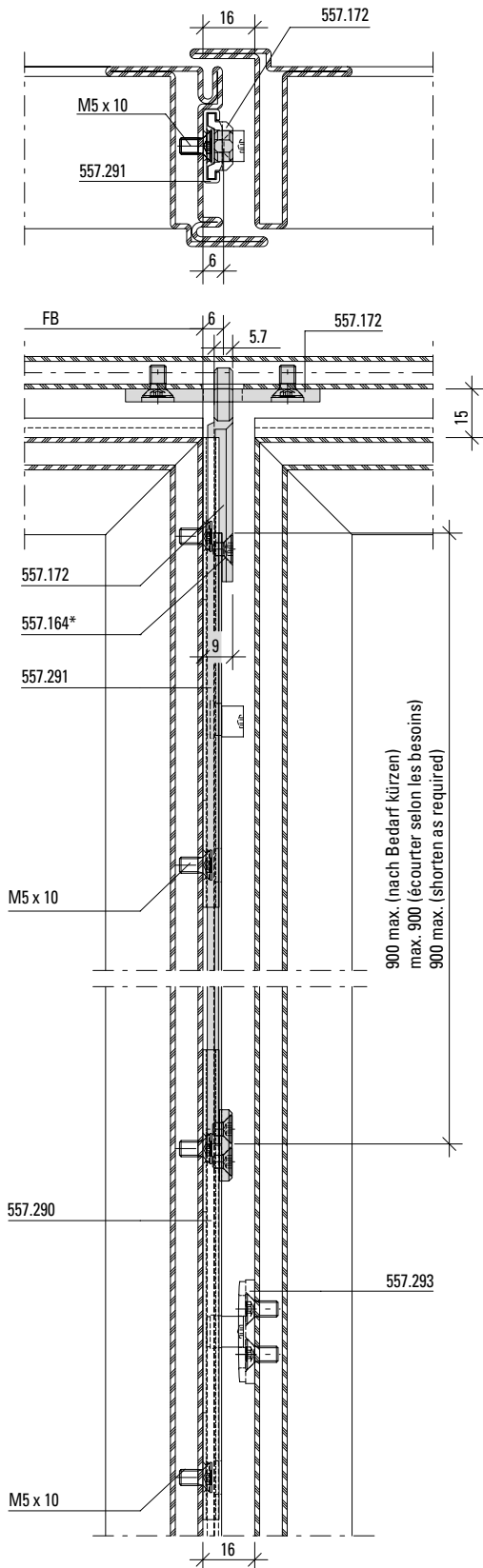

0-Stellung
 Position zéro
 Zero position

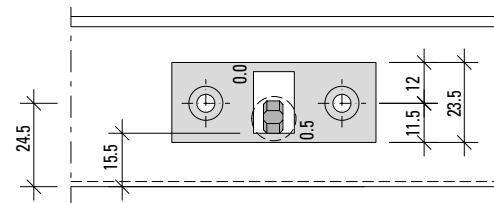

Erhöhter Anpressdruck
 Pression augmentée
 Increased contact pressure

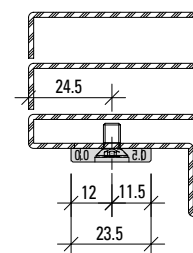
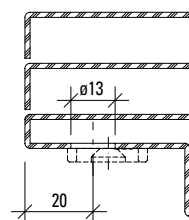
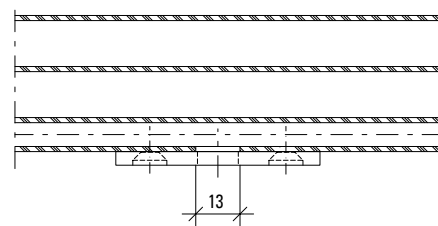
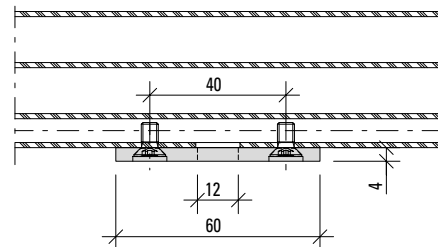

Verdeckt liegender Fensterbeschlag
Fenster zweiflügelig
Zusatzverriegelung oben

Ferrure de fenêtre non apparente
Fenêtre à deux vantaux
Verrouillage supplémentaire en haut

Concealed window fitting
Double-vent window
Additional locking point (top)

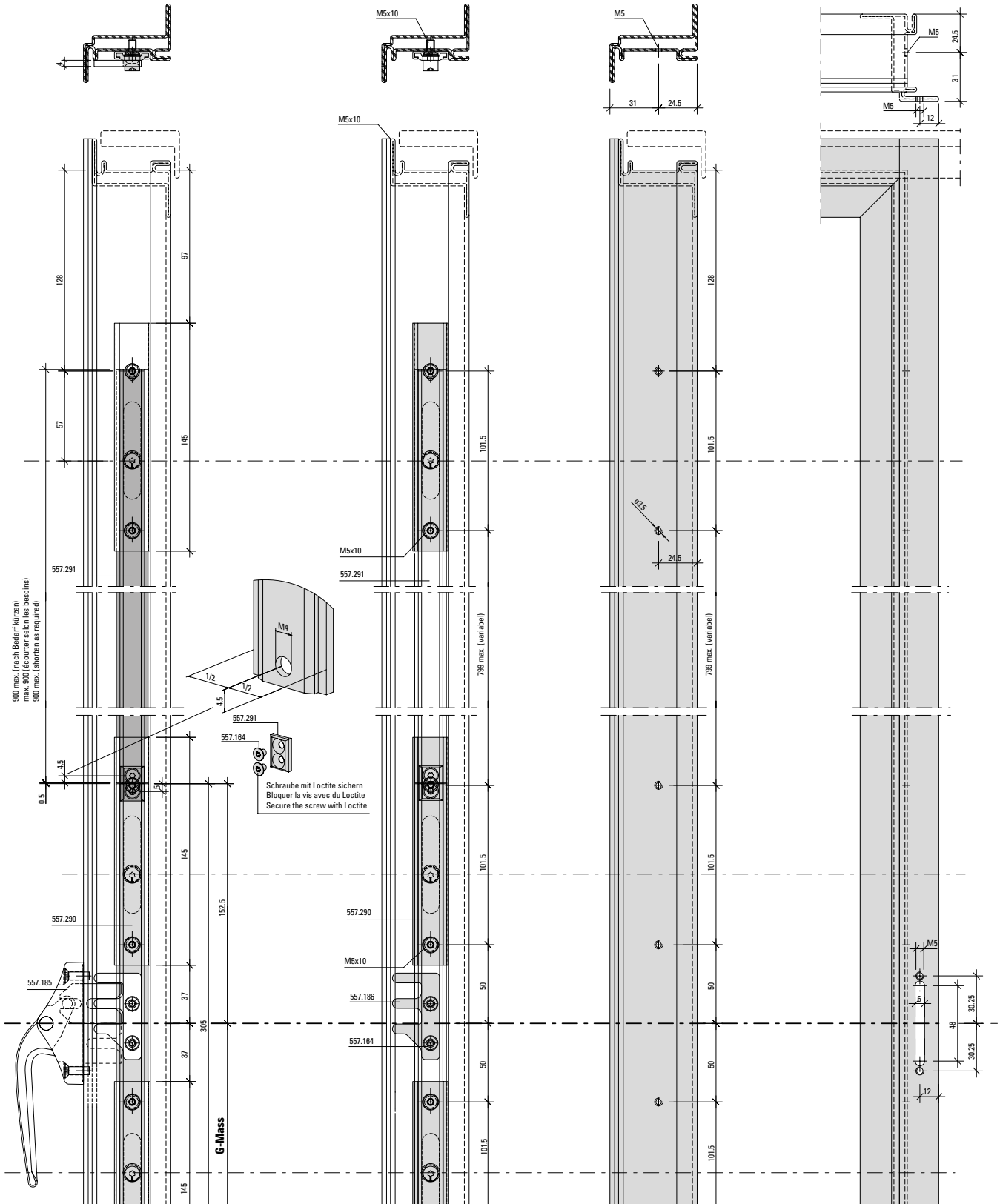

Verdeckt liegender Fensterbeschlag
Fenster zweiflügelig
Zusatzverriegelung oben

Ferrure de fenêtre non apparente
Fenêtre à deux vantaux
Verrouillage supplémentaire en haut

Concealed window fitting
Double-vent window
Additional locking point (top)

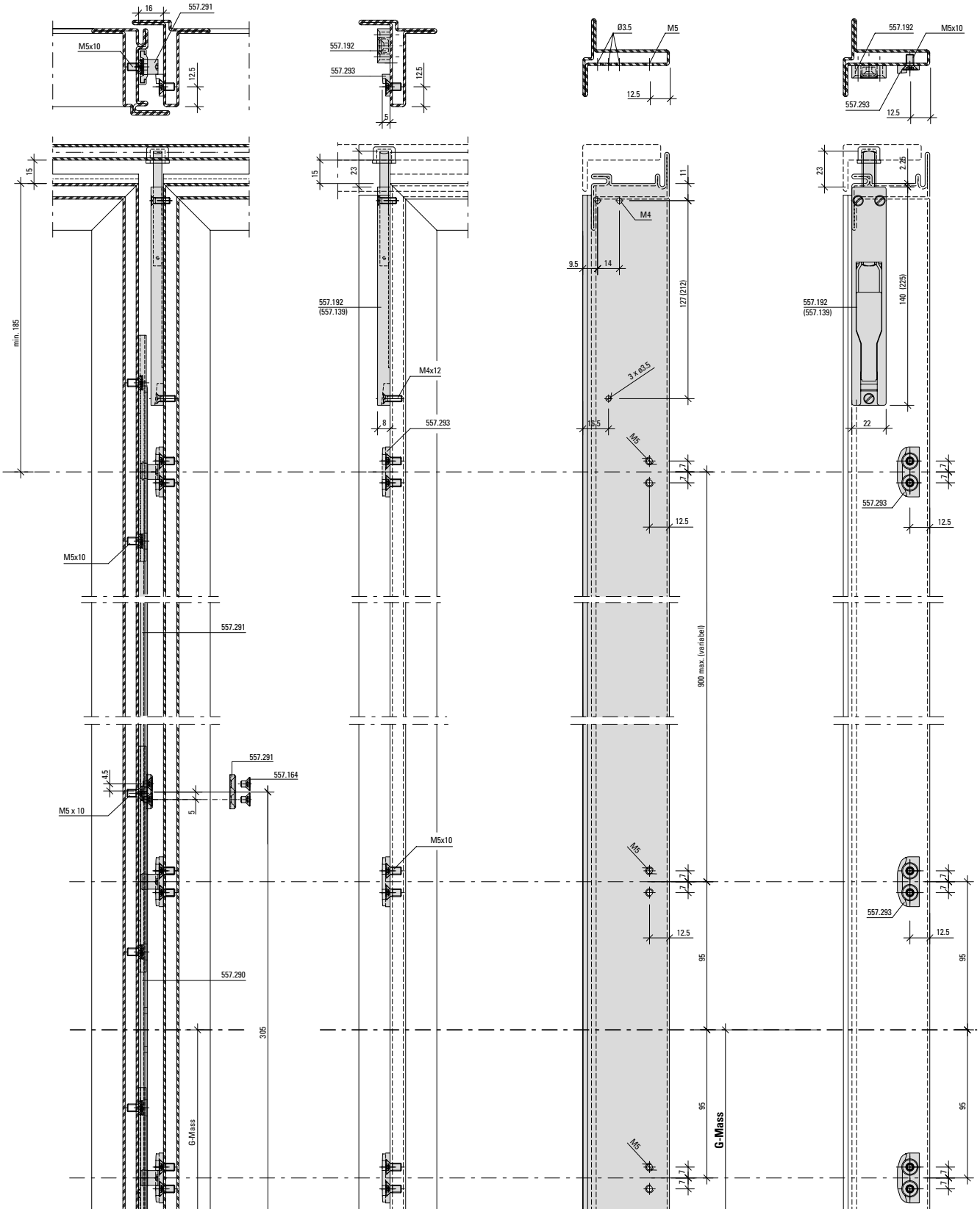

Verdeckt liegender Fensterbeschlag
Fenster zweiflügelig
Zusatzverriegelung unten

Ferrure de fenêtre non apparente
Fenêtre à deux vantaux
Verrouillage supplémentaire en bas

Concealed window fitting
Double-vent window
Additional locking point (bottom)

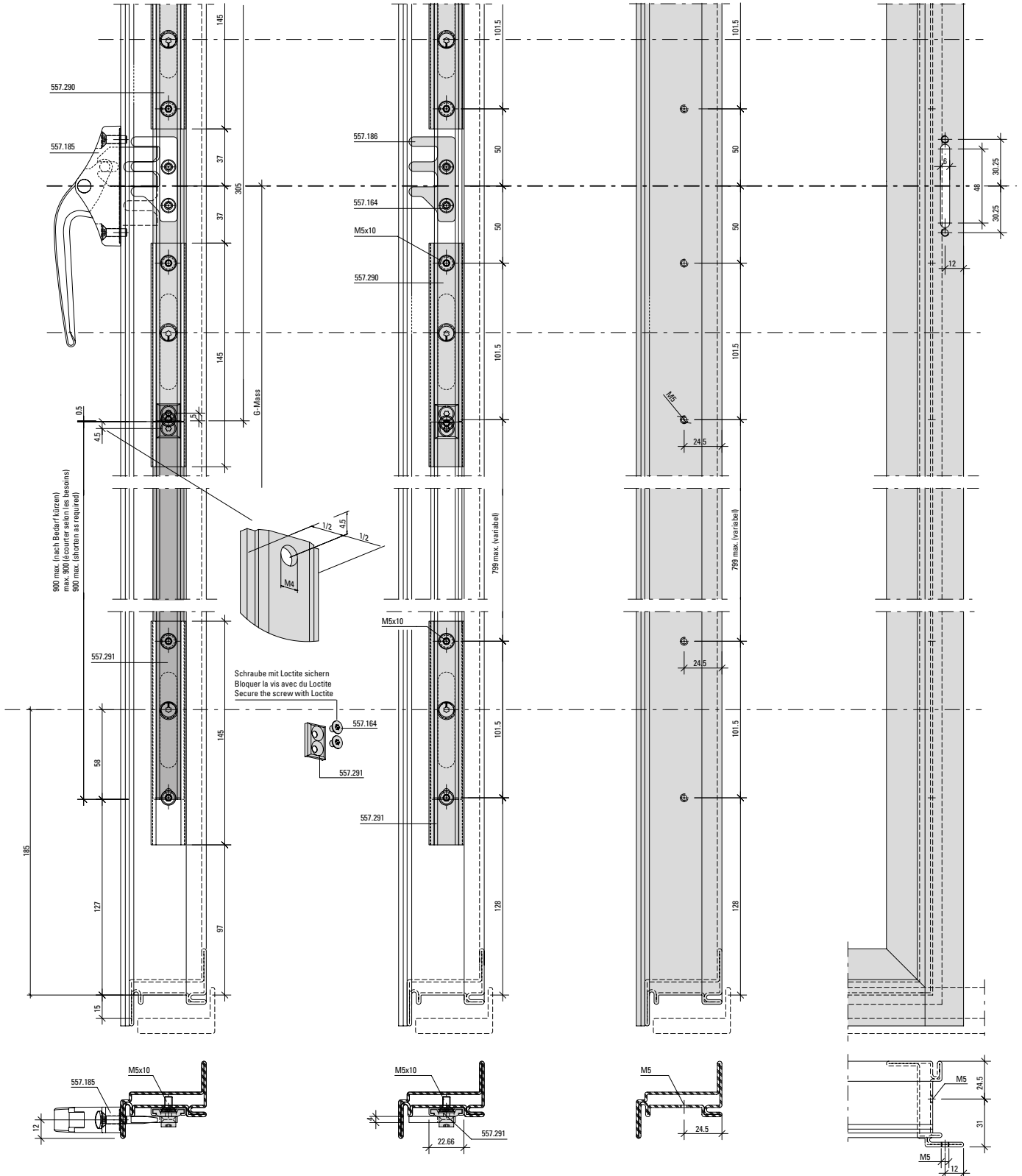

Verdeckt liegender Fensterbeschlag
 Fenster zweiflügelig
 Zusatzverriegelung unten

Ferrure de fenêtre non apparente
 Fenêtre à deux vantaux
 Verrouillage supplémentaire en bas

Concealed window fitting
 Double-vent window
 Additional locking point (bottom)

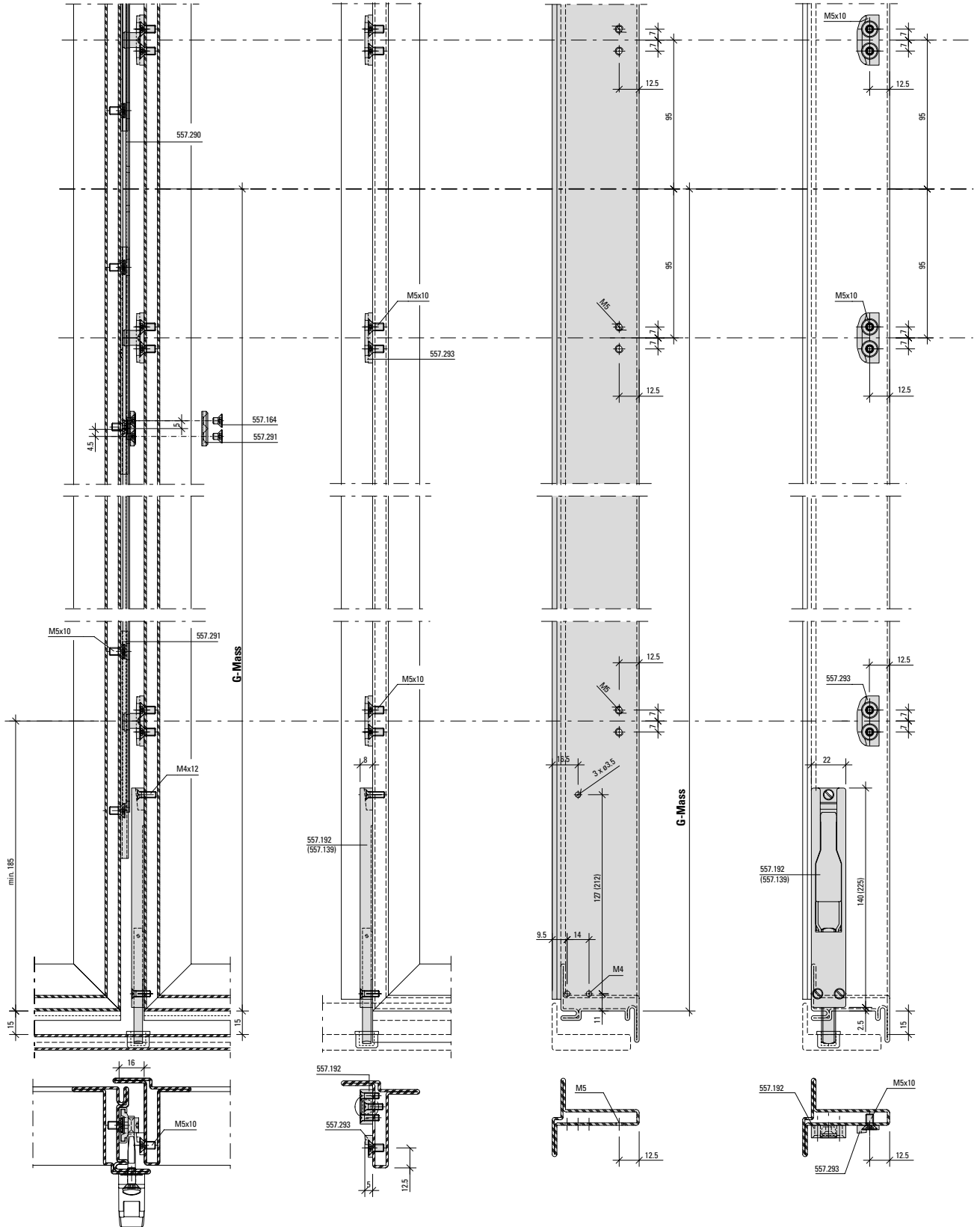

Einbau Fenstergriff
557.184/557.185

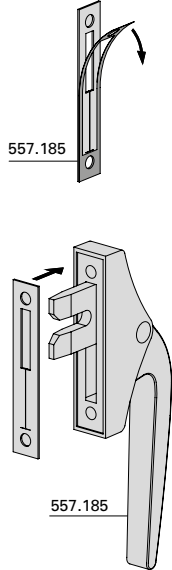

Montage poignée de fenêtre
557.184/557.185

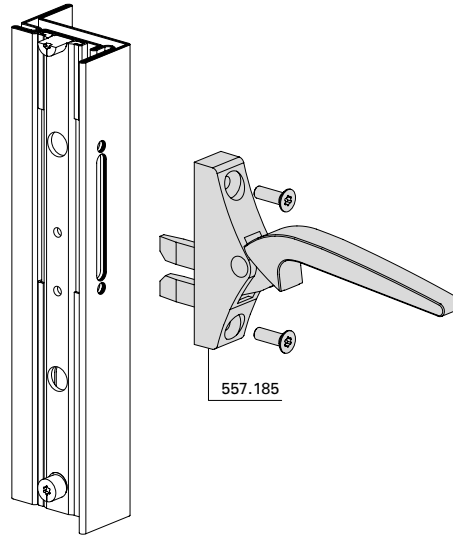

Installation of window handle
557.184/557.185

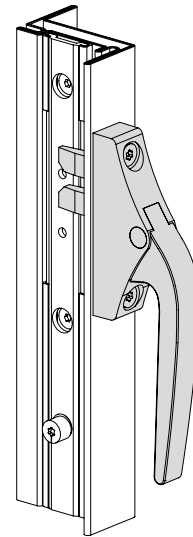

Einbau Griffmitnehmer
557.186 / 557.292

M5x10
 Schraube mit Loctite sichern
 Bloquer la vis avec du Loctite
 Secure the screw with Loctite

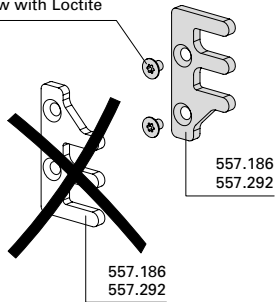

Montage entraîneur de poignée
557.186 / 557.292

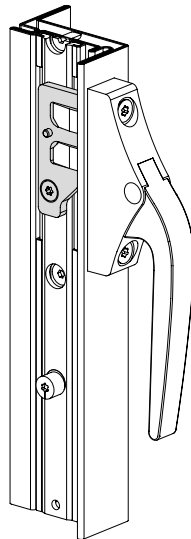

Installation of handle driver
557.186 / 557.292

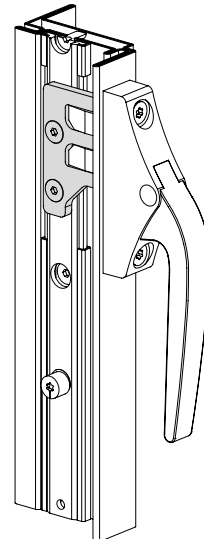

Verstellmöglichkeit $\pm 0,65$ mm
 Plage de réglage $\pm 0,65$ mm
 Range of adjustment $\pm 0,65$ mm

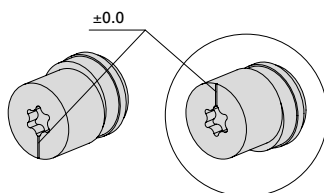

Fenster einflügelig
 Fenêtre à un vantail
 Single vent window

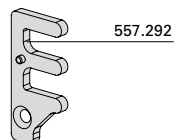

Fenster zweiflügelig
 Fenêtre à deux vantaux
 Double vent window

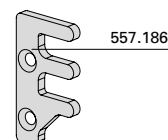

Auflaufbock 557.079

Bloc d'arrêt 557.079

Engagement block 557.079

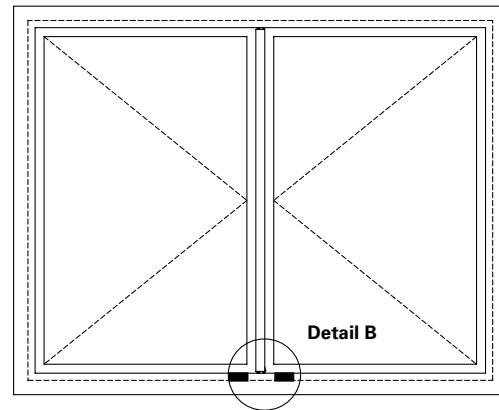
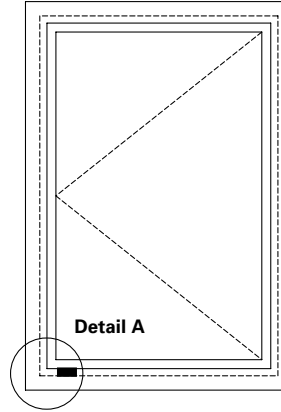
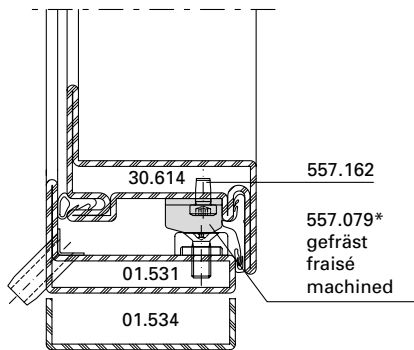
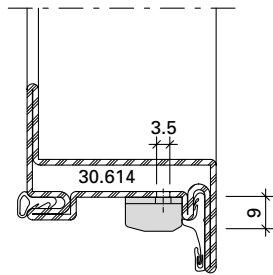
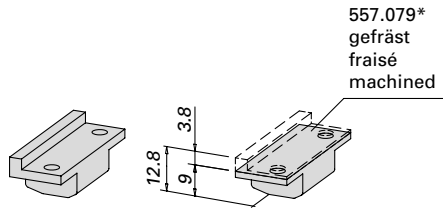

- * Durch Metallbauer auszuführen
- * A fabriquer par le métallier
- * To made by metal constructor

Detail A

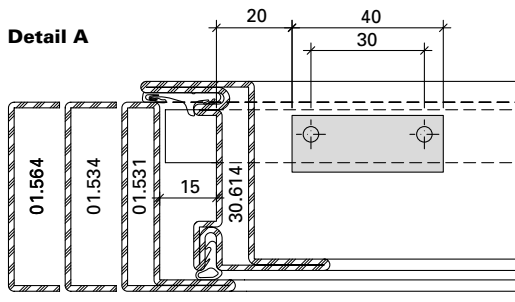

Detail B

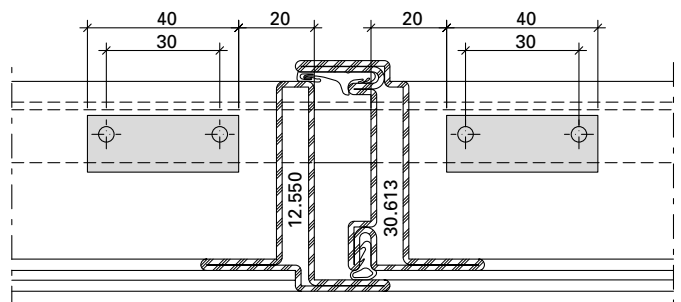

Kippflügel mit
 Oberlichtschnäpper 550.413

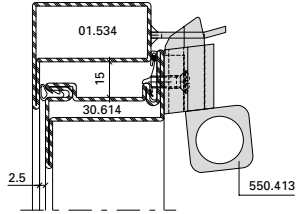

Vantail à soufflet avec
 loqueteau 550.413

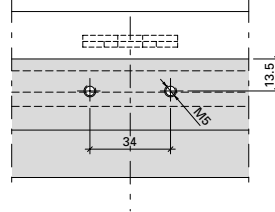
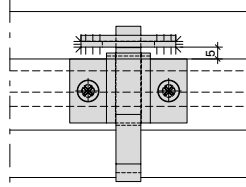

Bottom-hung vent with
 top light catch 550.413

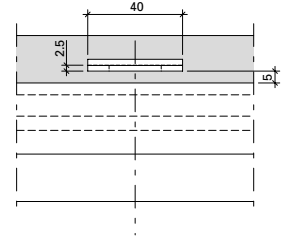

Falzschere 550.414

Compas d'arrêt pour
 fenêtre à soufflet 550.414

Top light stay 550.414

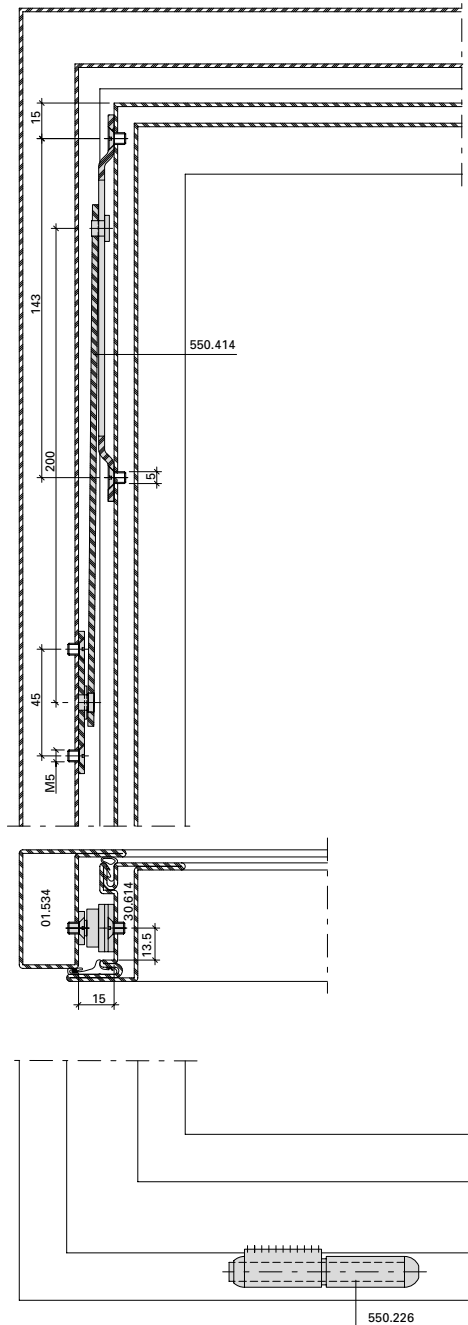
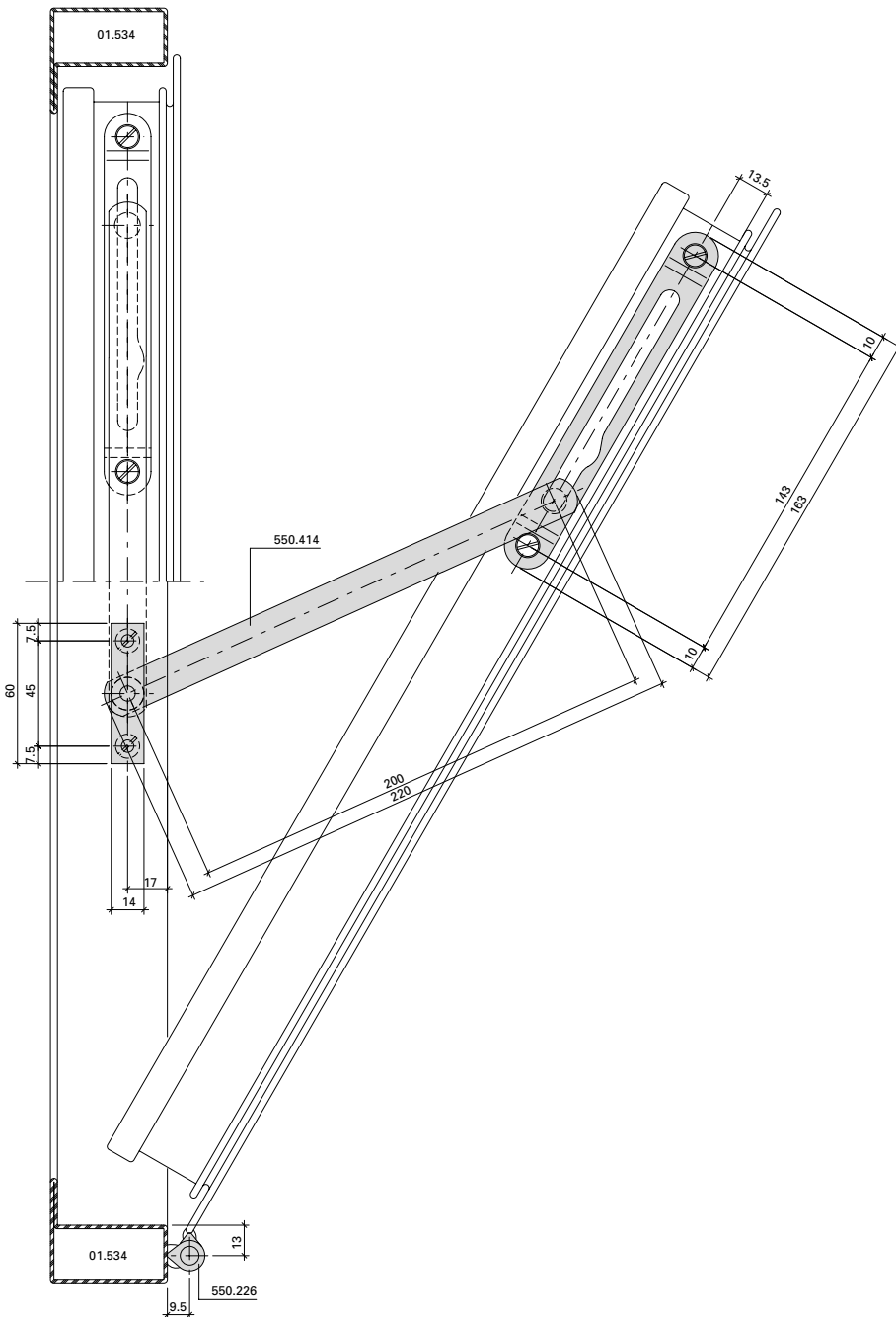

Beschlagenbau Fenstertüren
 Fallenriegel-Schloss 550.191
 Einflügelige Türe

Montage de la ferrure portes-fenêtres
 Serrure à mortaiser 550.191
 Porte à un vantail

Fittings installation for window doors
 Latch-and-bolt lock 550.191
 Single-leaf door

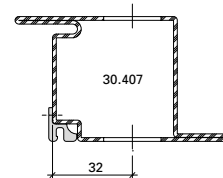
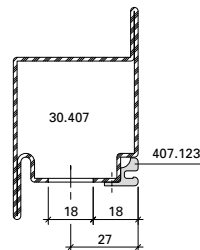
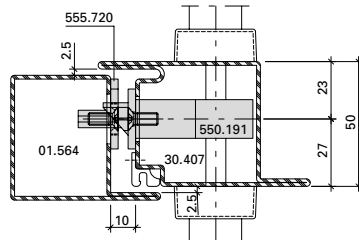
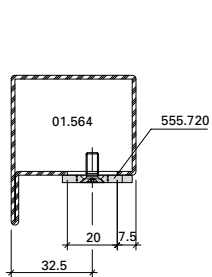
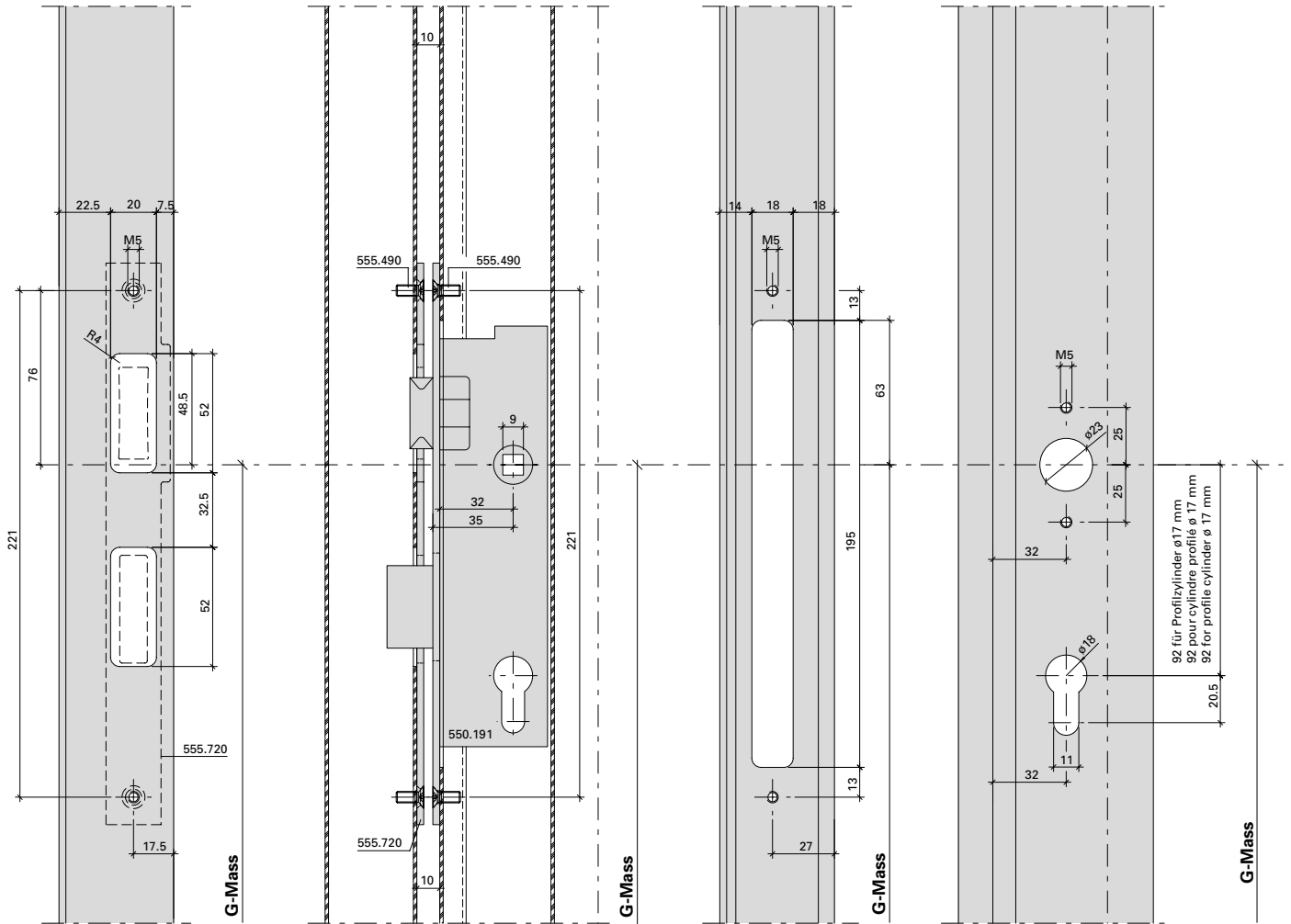

Beschlageinbau Fenstertüren
 Rollfallen-Schloss 550.193
 Einflügelige Türe

Montage de la ferrure portes-fenêtres
 Serrure à mortaiser à rouleau 550.193
 Porte à un vantail

ittings installation for window doors
 Roller latch lock 550.193
 Single-leaf door

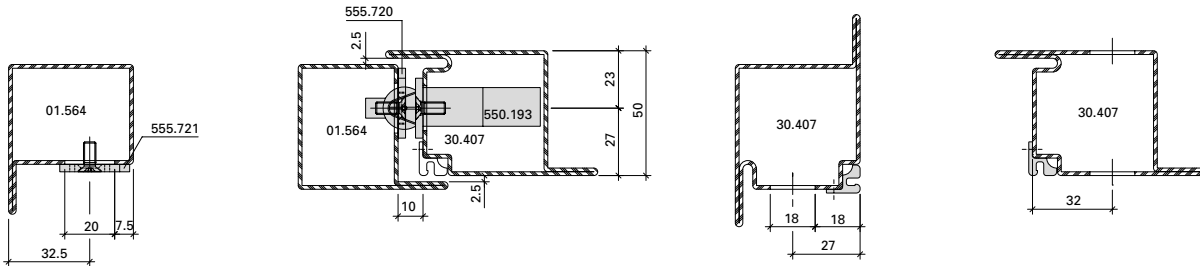
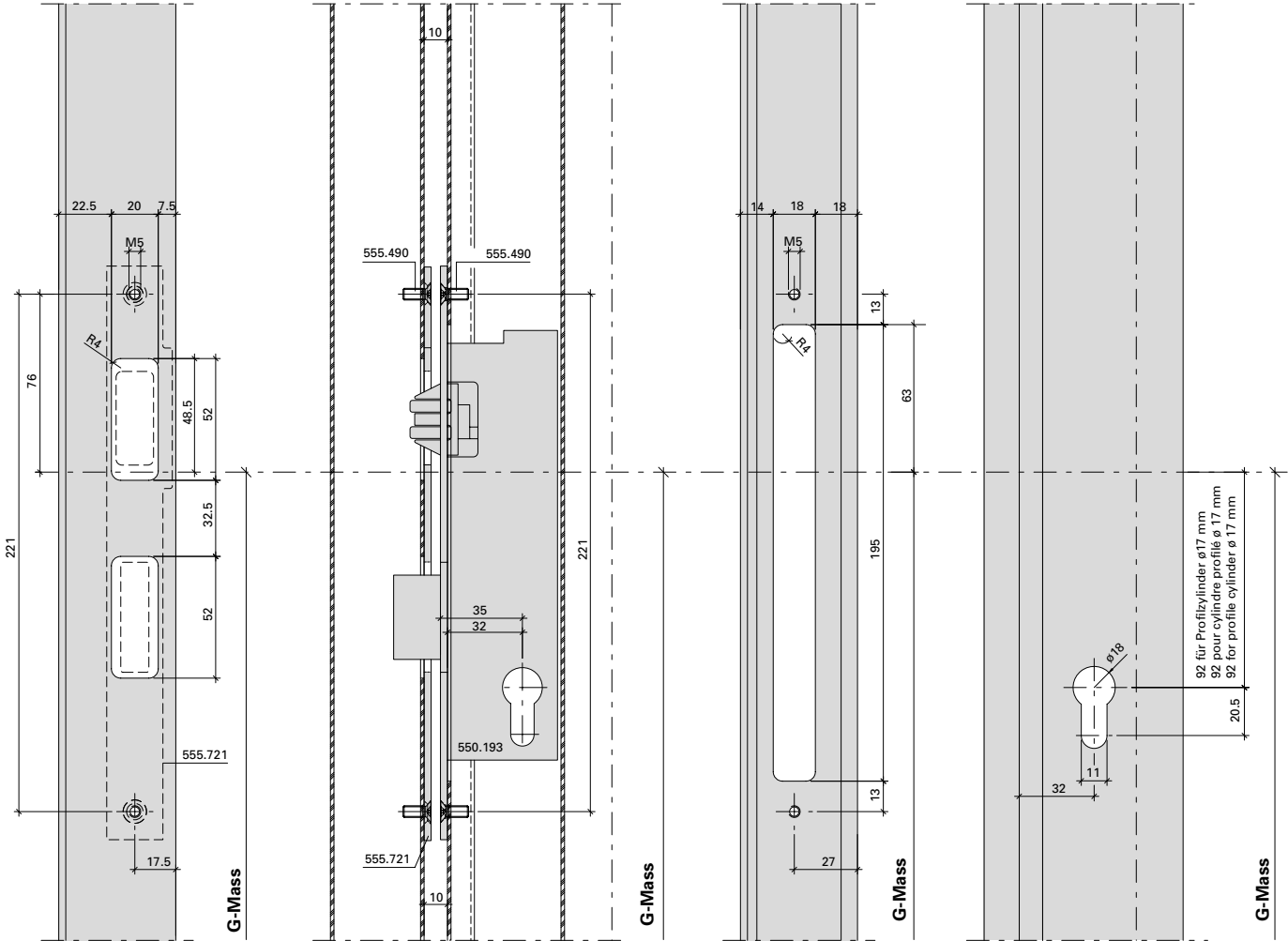

Beschlageinbau Fenstertüren
 Fallenriegel-Schloss 559.210
 Einflügelige Türe

Montage de la ferrure portes-fenêtres
 Serrure à mortaiser 559.210
 Porte à un vantail

Fittings installation for window doors
 Latch-and-bolt lock 559.210
 Single-leaf door

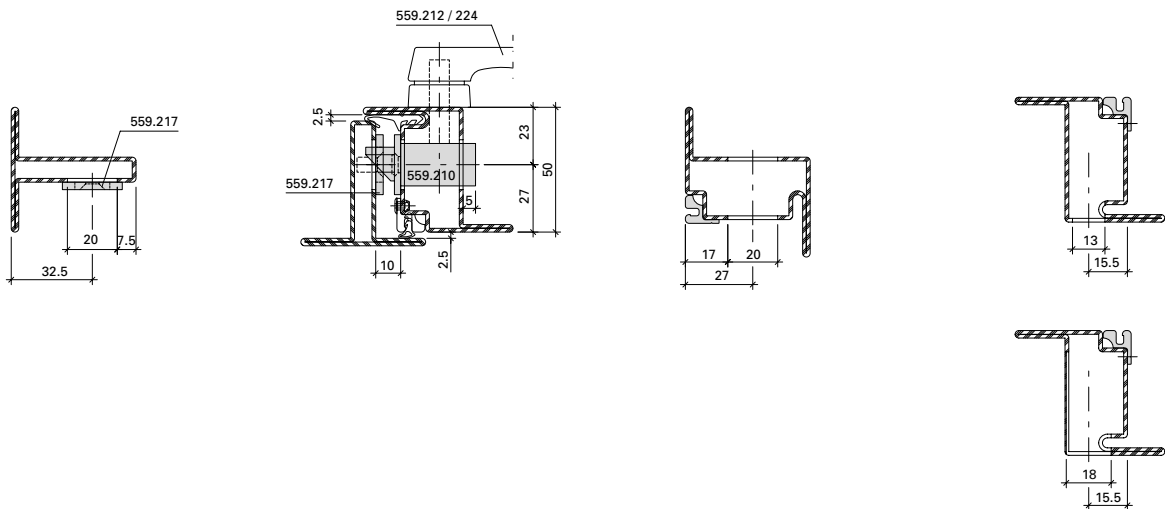
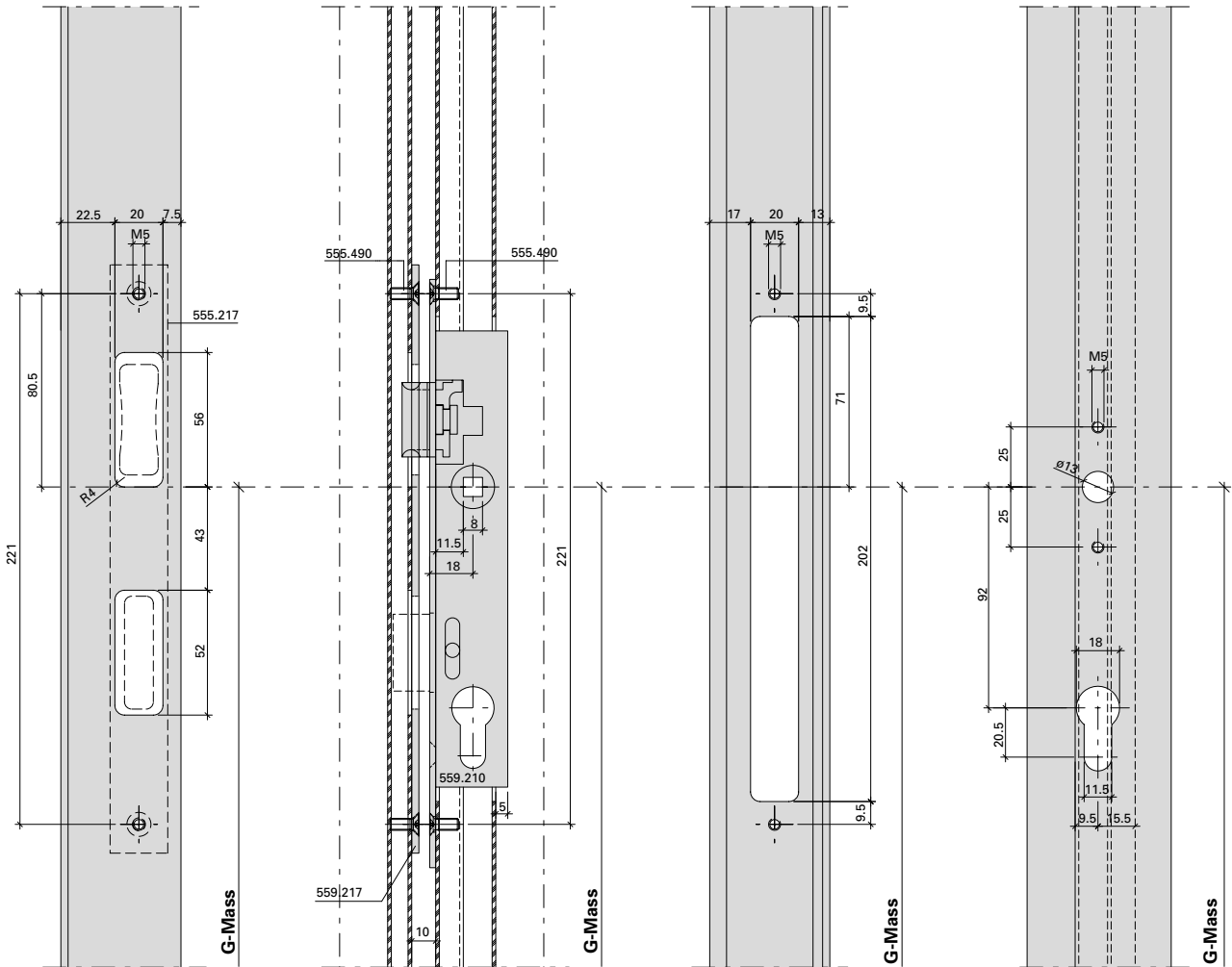

Beschlageinbau
 Fenstertüren
 Mehrfach-
 verriegelungs-
 Schloss 555.910
 Einflügelige Türe

Montage
 de la ferrure
 portes-fenêtres

Serrure à
 verrouillage
 multiple 555.910
 Porte à un vantail

Fittings installation
 for window doors

Multi-point lock
 555.910
 Single-leaf door

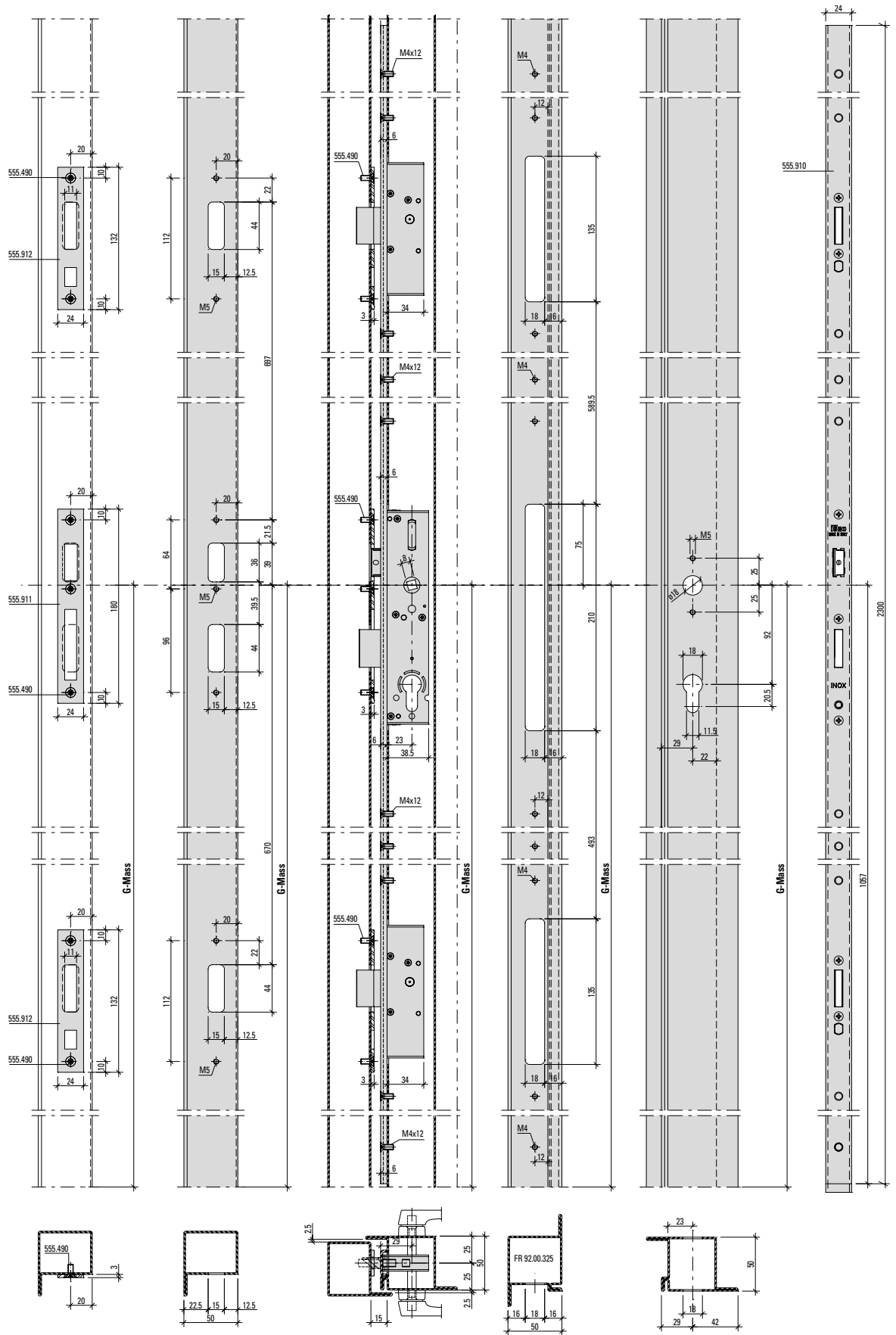

Inhaltsverzeichnis	Sommaire	Content	
Ausbildungen	Détails d'angle	Design of corner details	160
Zuschnitt und Zusammenbau Eckausbildung Fenstertüren	Découpe et assemblage Formation d'angle portes-fenêtres	Cutting and assembly Corner construction of window doors	167
Einbau Aluminium-Zusatzprofil 407.123 für Fenstertüren mit Schloss und Drücker	Montage profilé complémentaire en aluminium 407.123 pour les portes-fenêtres avec serrure et béquille	Installation of aluminium additional profile 407.123 for window doors with lock and handle	169
Zuschnitt und Zusammenbau Eckausbildung/Profilwechsel Fenstertüre	Découpe et assemblage Formation d'angle/changement de profilé portes-fenêtres	Cutting and assembly Corner construction/reverse rebate profile of window doors	170
Einbau Wetterschenkel 407.009 und Endstück 450.070	Montage renvoi d'eau 407.009 et embout 450.070	Installation of drip bar 407.009 and end piece 450.070	171
Anordnung und Einbau Entwässerungstülle 450.045 Fensterrahmen	Disposition et montage Douille d'évacuation d'eau 450.045 Cadre de fenêtre	Arrangement and installation Drainhole insert 450.045 Window frame	172
Anordnung und Einbau Flügelfalzprofil 407.090 Rahmen	Disposition et montage Profilé de feuillure de vantail 407.090 Cadre	Arrangement and installation Vent rebate profile 407.090 Frame	173
Glasfalzbelüftung Fensterflügel	Aération des feuillures à verre Vantail de fenêtre	Glazing rebate ventilation Window vent	174
Glasfalzbelüftung Festverglasung	Aération des feuillures à verre Vitrage fixe	Glazing rebate ventilation Fixed glazing	175
Verdeckt liegende Glasfalzbelüftung Festverglasung mit Trockenverglasung/ Nassverglasung	Aération non visible des feuillures à verre pour vitrage fixe Vitrage à sec/ vitrage à mastic	Concealed glazing rebate ventilation Fixed glazing Dry glazing/ glazing with sealing	176
Einbau Glasfalzbelüftung Festverglasung	Montage feuillures à verre Vitrage fixe	Installation glazing rebate ventilation Fixed glazing	178
Verdeckt liegende Glasfalzbelüftung Festverglasung Winkel für Glasfalzbelüftung 450.110 oben	Aération non visible des feuillures à verre pour vitrage fixe avec Equerres pour aération des feuillures à verre 450.110 en haut	Concealed glazing rebate ventilation Fixed glazing Angle for glazing rebate ventilation 450.110 top	179
Einbau Dichtung 455.000 in Fensterflügel	Montage joint 455.000 dans le vantail de fenêtre	Installation of weatherstrip 455.000 in the window vent	180
Einbau Dichtung 455.046 in Fensterflügel	Montage joint 455.046 dans le vantail de fenêtre	Installation of weatherstrip 455.046 in the window vent	181
Einbau Dichtungstück Stulpbereich	Montage embout d'étanchéité pour fenêtre à deux vantaux	Installation weatherstrip for double vent windows	183
Glaseinbau mittels Trockenverglasung	Pose des verres avec vitrage à sec	Glazing with dry glazing	184
Glaseinbau mittels Nassverglasung	Pose des verres avec vitrage à mastic	Glazing with glazing with sealing	186
Verklotzen der Fenster	Calage des fenêtres	Glazing blocks of the windows	190

Ausbildung Eckdetail
Festverglasung/Türe

Détail d'angle
Vitrage fixe/porte

Design of corner detail
Fixed glazing/doors

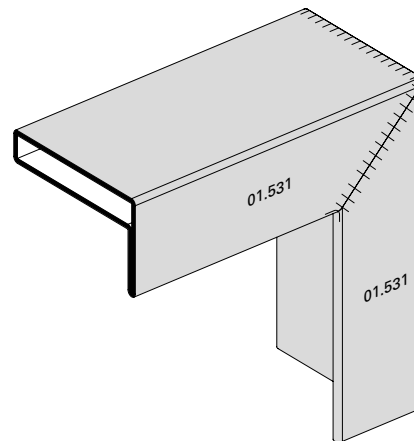
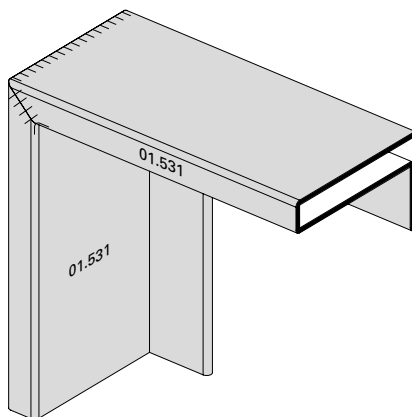
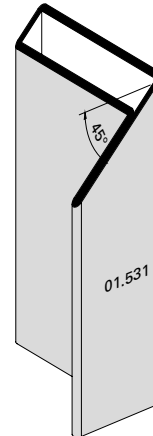
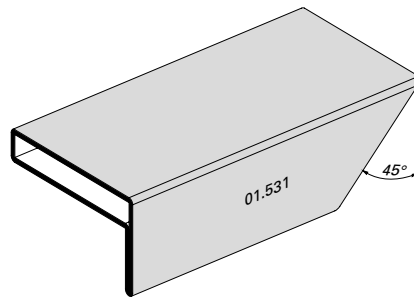
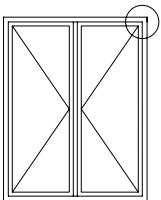
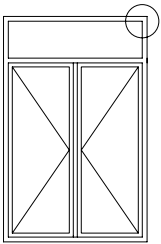

Ausbildung T-Staoss Riegel
Festverglasung/Türe

Détail de raccordement en T traverse
Vitrage fixe/porte

Design of transom T-joint
Fixed glazing/doors

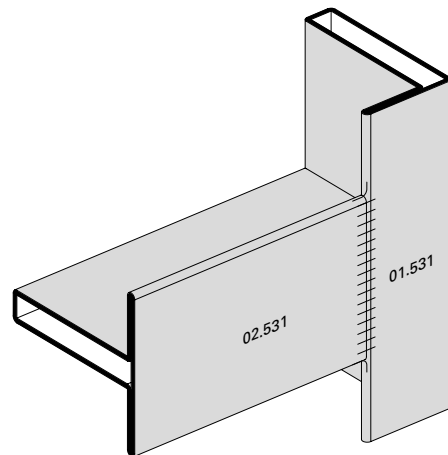
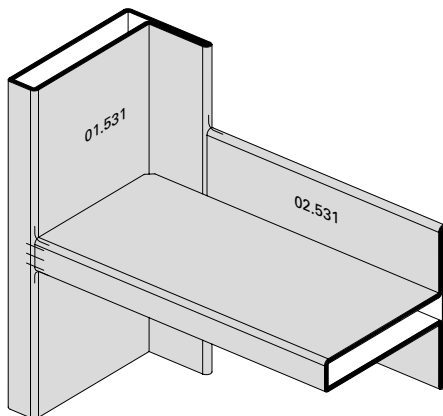
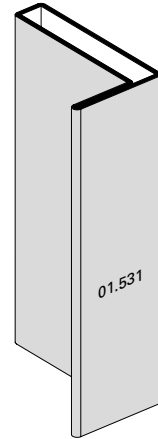
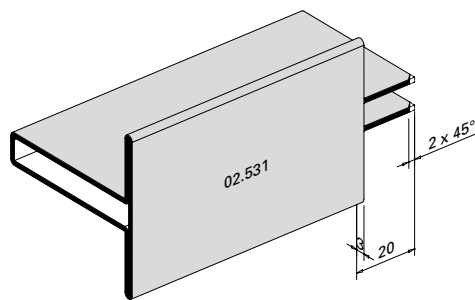
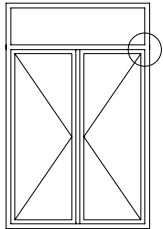
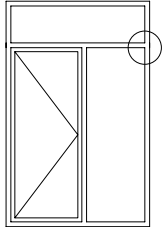

Ausbildung T-Stoss Pfosten
Türe/Festverglasung

Détail de raccordement en T montant
Porte/vitrage fixe

Design of mullion T-joint
Doors/fixed glazing

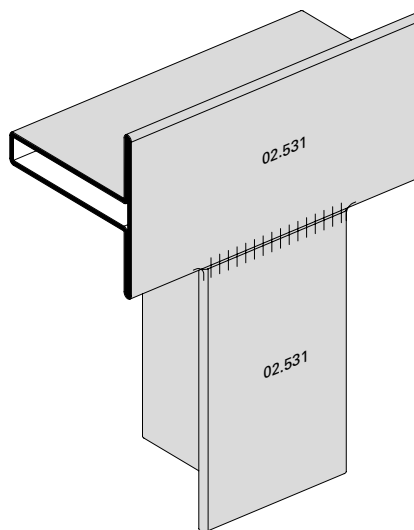
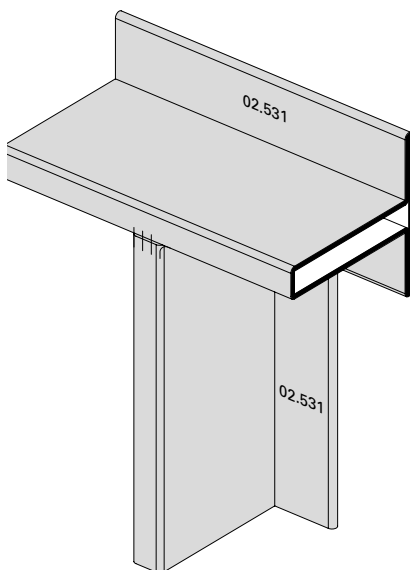
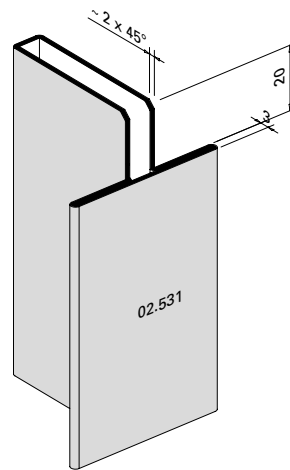
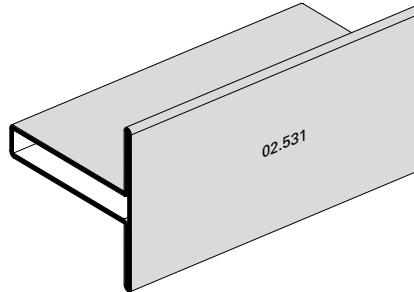
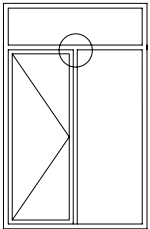

Ausbildung Kreuzpunkt Pfosten-Riegel
Türe/Festverglasung

Détail point d'intersection
montant-traverse
Porte/vitrage fixe

Design of mullion/transom
intersection point
Doors/fixed glazing

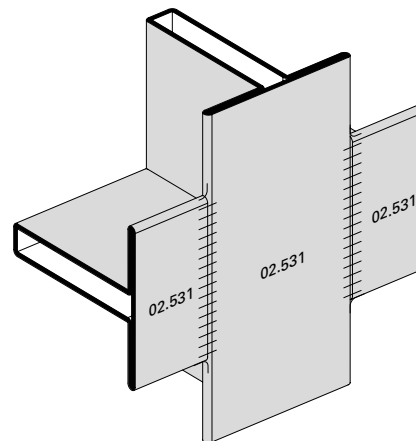
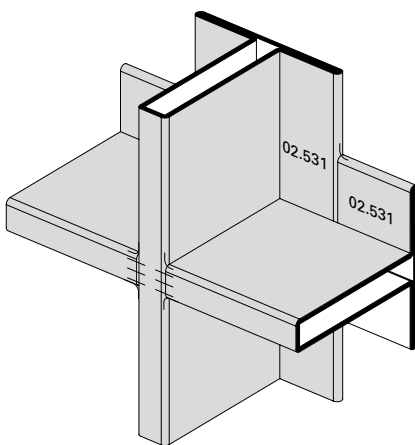
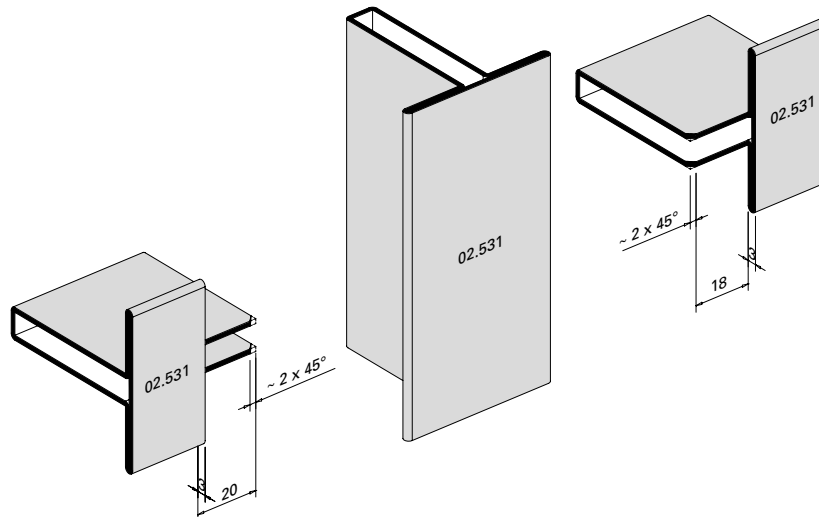
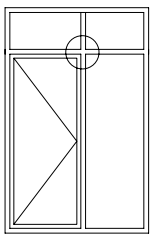

Ausbildung Eckdetail
Fensterflügel

Détail d'angle
Vantail de fenêtre

Design of corner detail
Window vent

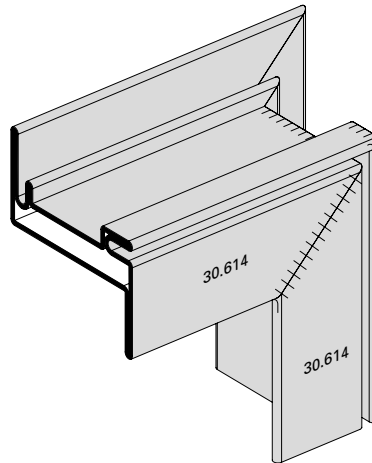
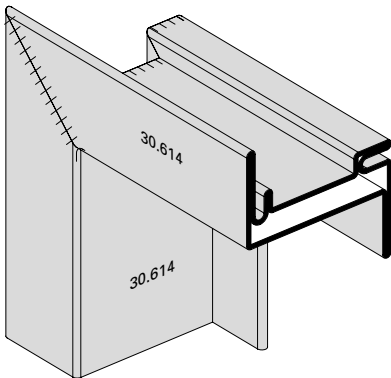
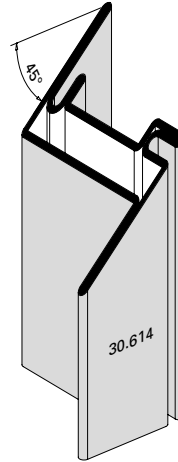
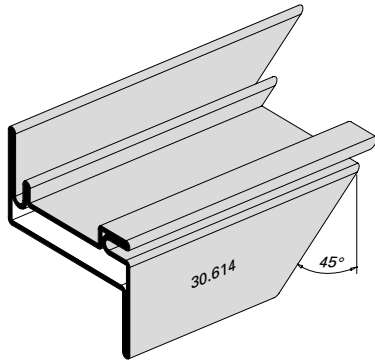
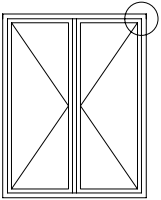

Ausbildung Stulpflügel-Detail
 Variante 1

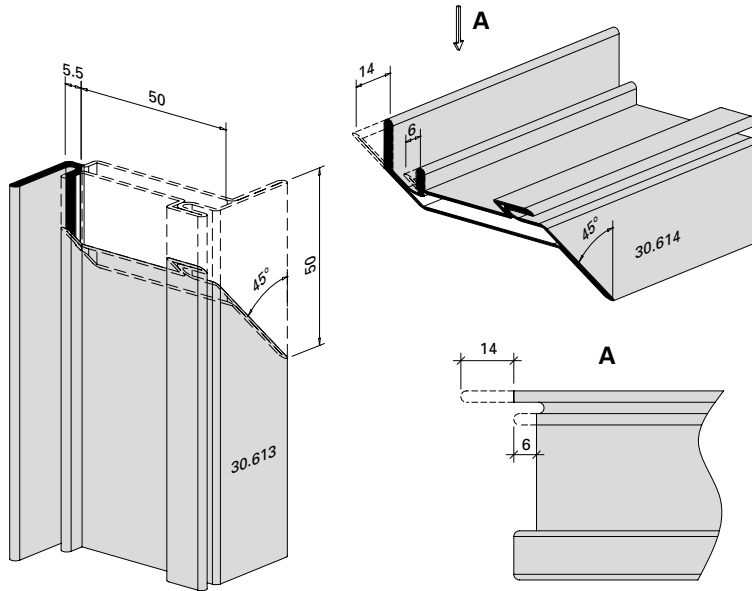

Détail vantail semi-fixe
 Variante 1

Design of double-vent vent detail
 Type 1

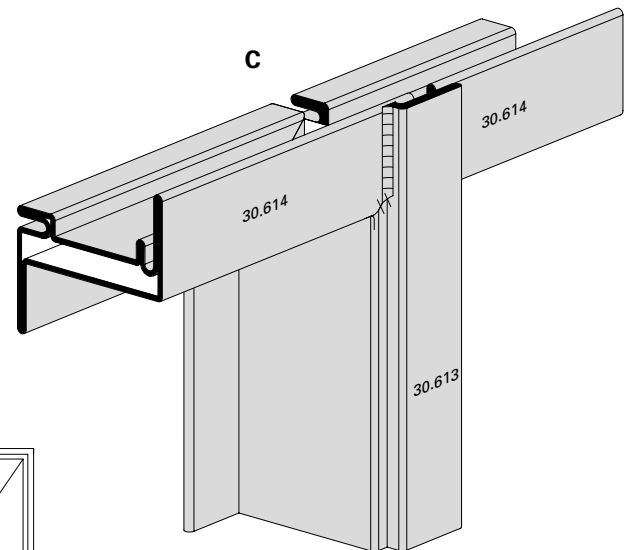
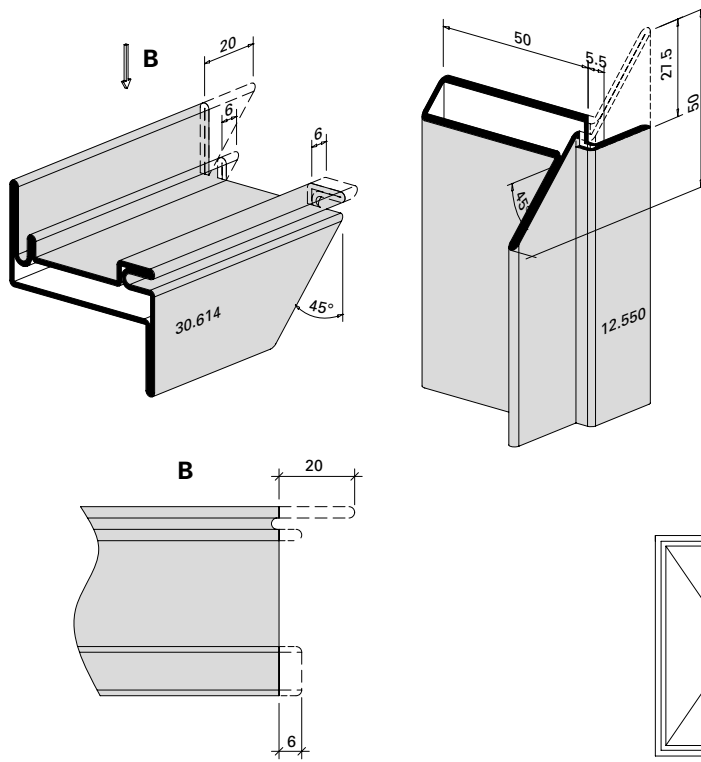
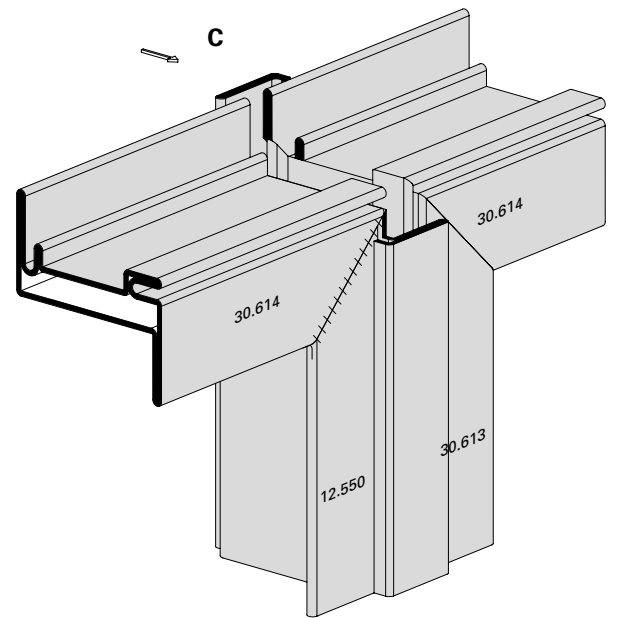

Ausbildung Stulpflügel-Detail
 Variante 2

Détail vantail semi-fixe
 Variante 2

Design of double-vent vent detail
 Type 2

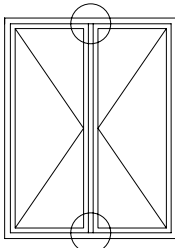
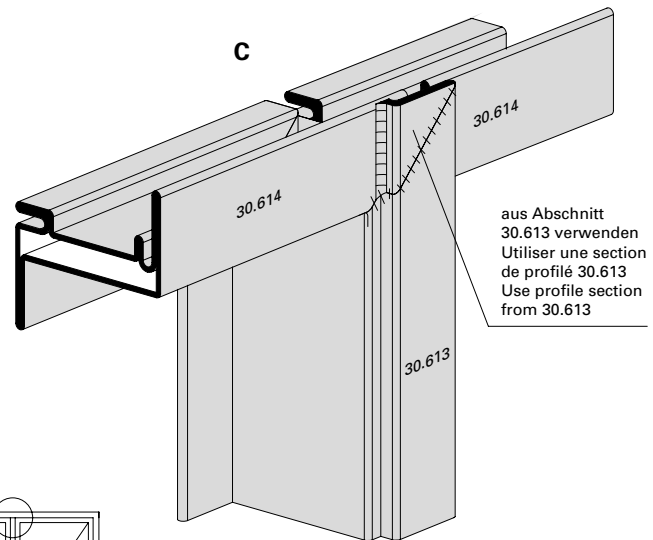
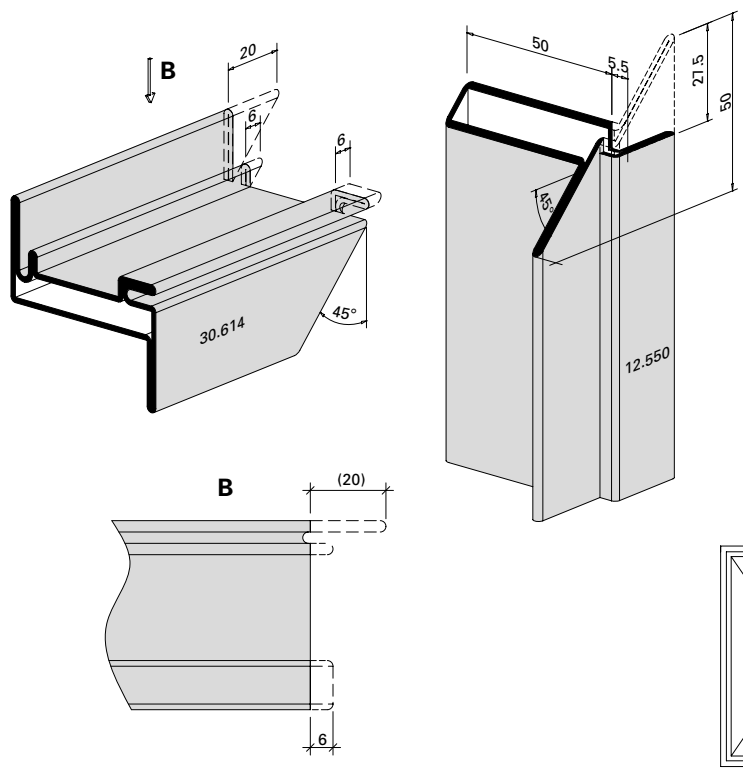
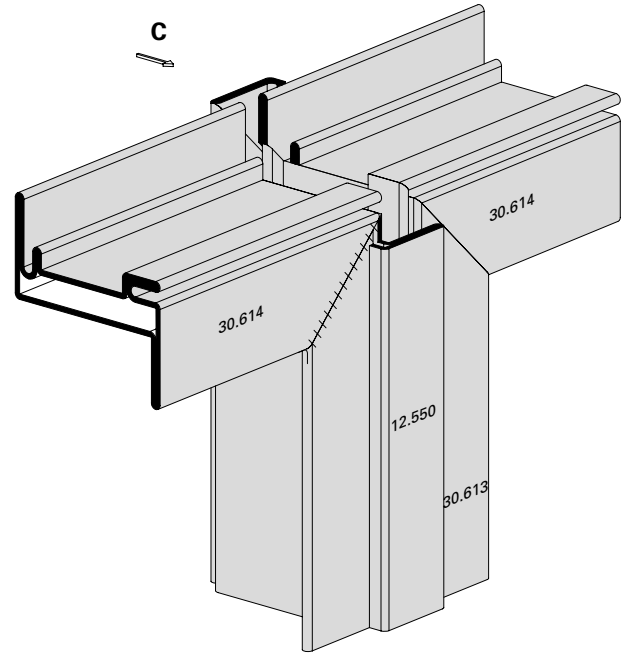
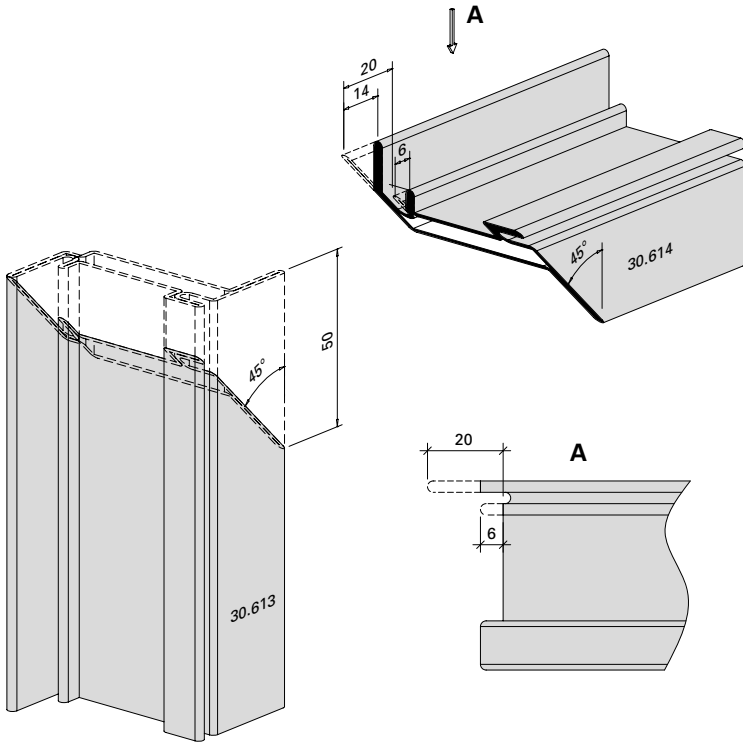

Zuschnitt und Zusammenbau
 Eckausbildung Fenstertüren
 mit 30.407 und 30.614
 Variante 1

Découpe et assemblage
 Formation d'angle portes-fenêtres
 avec 30.407 et 30.614
 Variante 1

Cutting and assembly
 Corner construction of window doors
 with 30.407 and 30.614
 Type 1

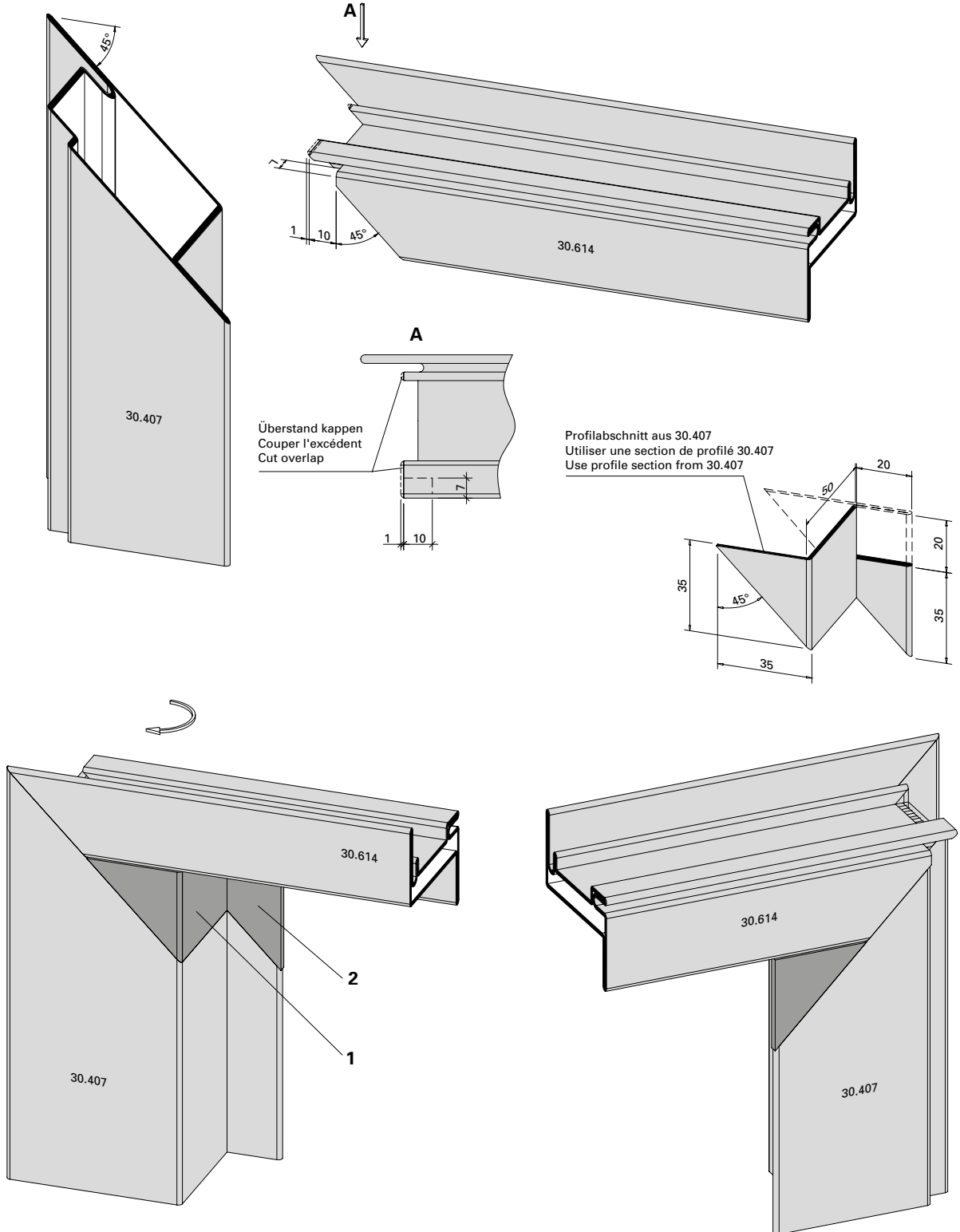

Zuschnitt und Zusammenbau
 Eckausbildung Fenstertüren
 mit 30.407 und 30.614
 Variante 2

Découpe et assemblage
 Formation d'angle portes-fenêtres
 avec 30.407 et 30.614
 Variante 2

Cutting and assembly
 Corner construction of window doors
 with 30.407 and 30.613
 Type 2

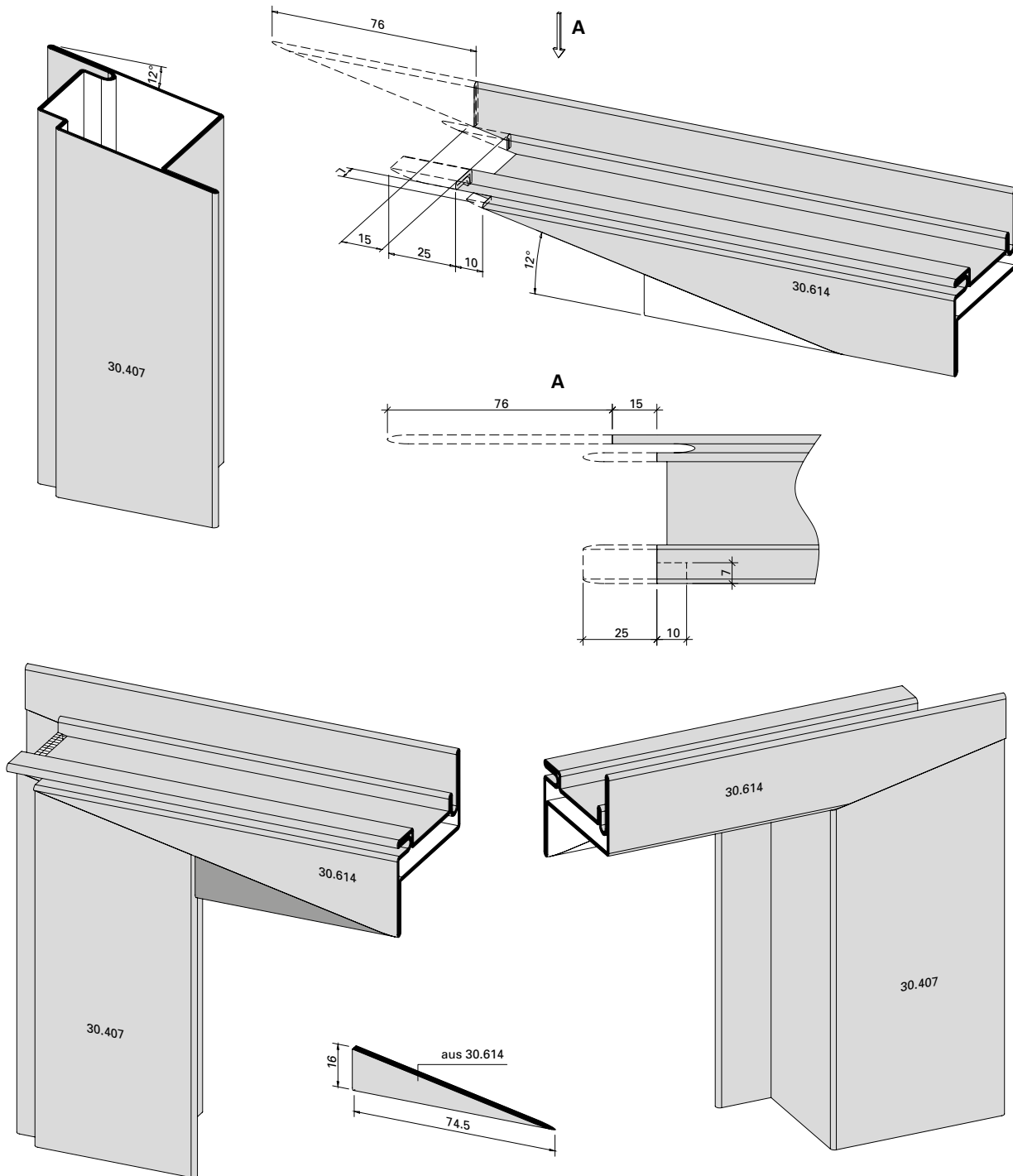

Einbau Aluminium-Zusatzprofil
 407.123 für Fenstertüren mit Schloss
 und Drücker

Montage profilé complémentaire
 en aluminium 407.123 pour les
 portes-fenêtres avec serrure et
 béquille

Installation of aluminium additional
 profile 407.123 for window doors
 with lock and handle

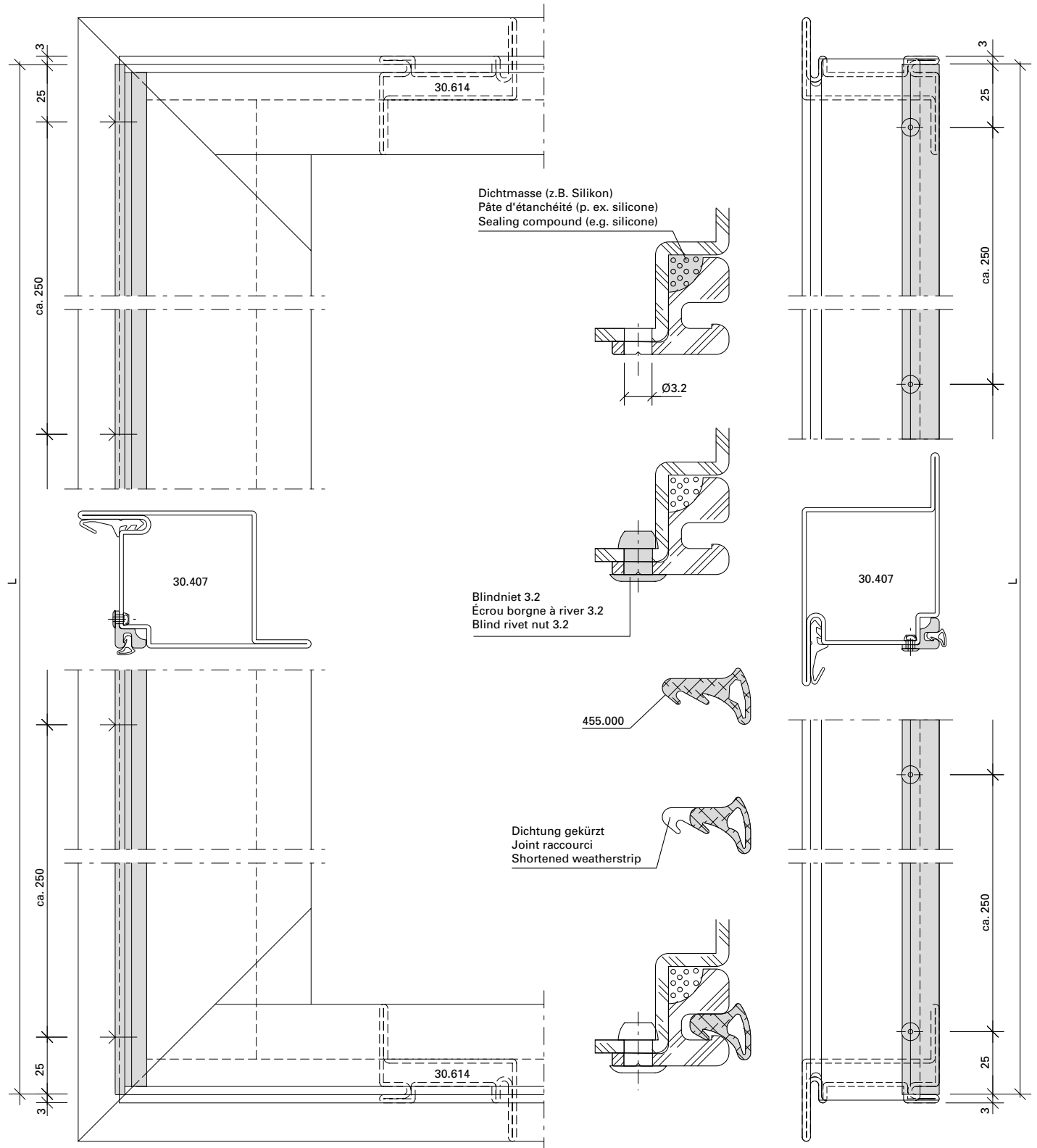

Zuschnitt und Zusammenbau
 Eckausbildung/Profilwechsel
 Fenstertüren mit FR 92.00.323
 und 30.614
 (nur für Markt Frankreich)

Découpe et assemblage
 Formation d'angle/changement de
 profilé portes-fenêtres avec
 FR 92.00.323 et 30.614
 (uniquement pour le marché français)

Cutting and assembly
 Corner construction/reverse rebate
 profile of window doors with
 FR 92.00.323 and 30.614
 (only for French market)

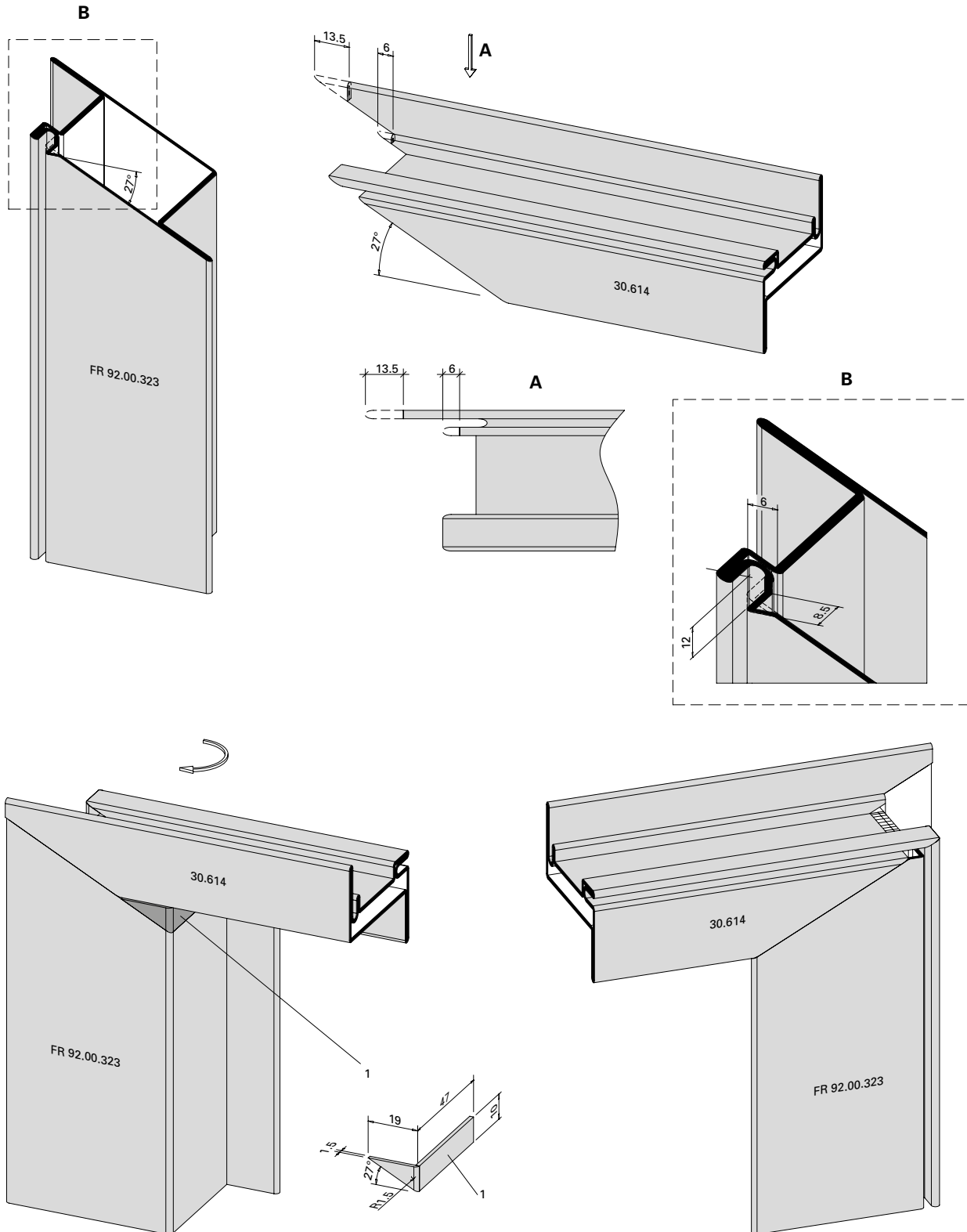

Einbau Wetterschenkel 407.009
 und Endstück 450.070
 (Flügel nach innen öffnend)

Montage renvoi d'eau 407.009 et
 embout 450.070
 (Vantail ouvrant vers l'intérieur)

Installation of drip bar 407.009 and
 end piece 450.070
 (Inward-opening vent)

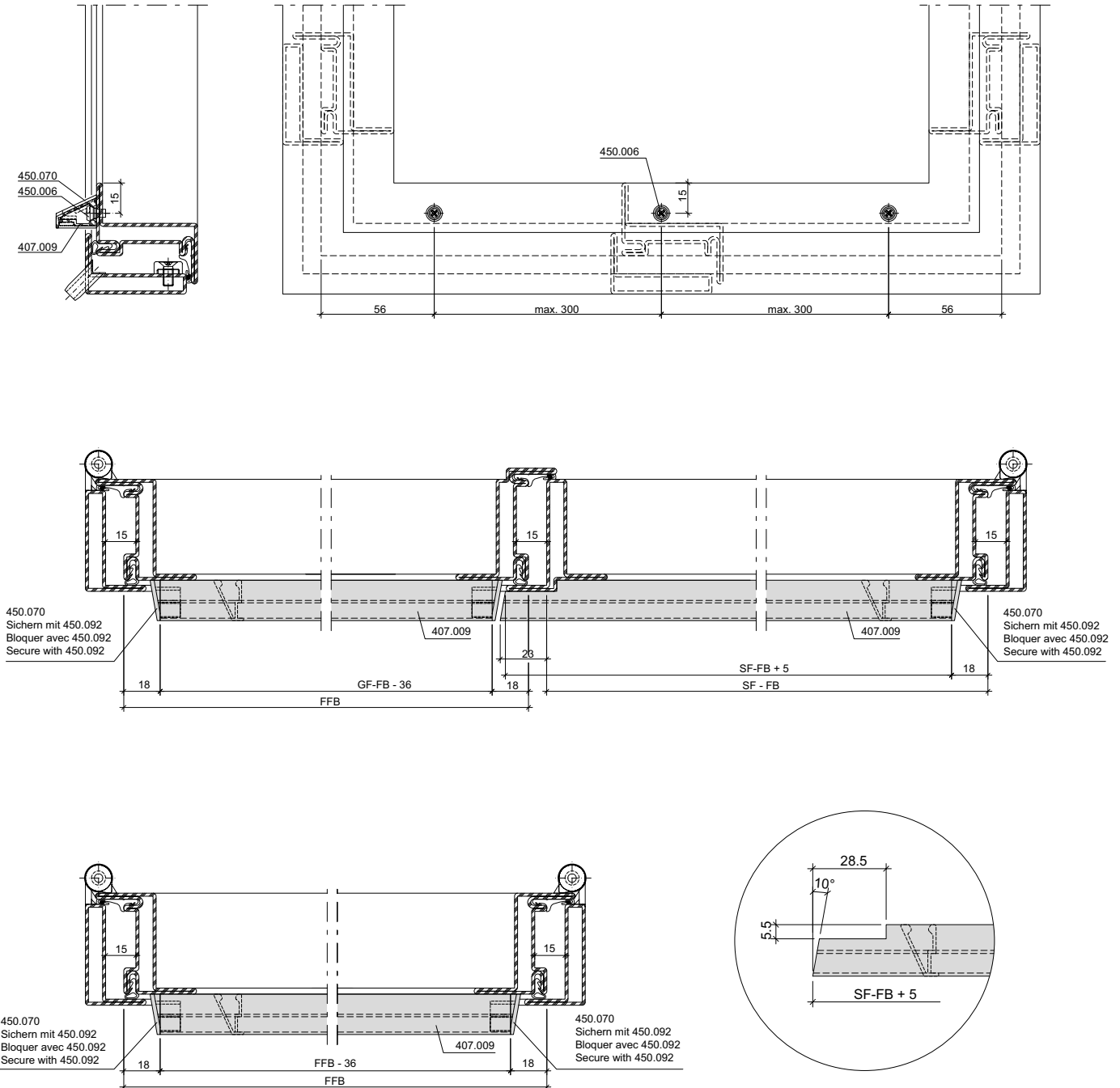

Anordnung und Einbau
 Entwässerungstülle 450.045
 Fensterrahmen

Disposition et montage
 Douille d'évacuation d'eau 450.045
 Cadre de fenêtre

Arrangement and installation
 Drainhole insert 450.045
 Window frame

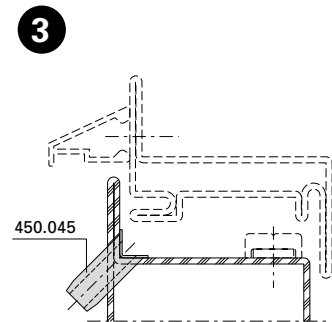
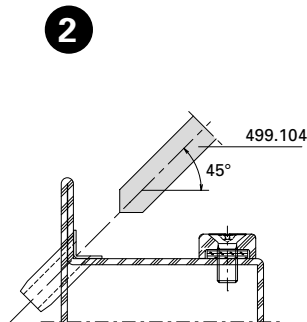
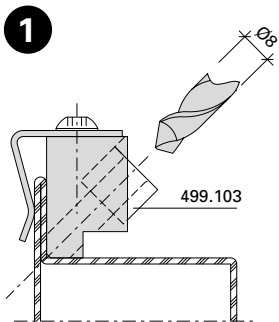
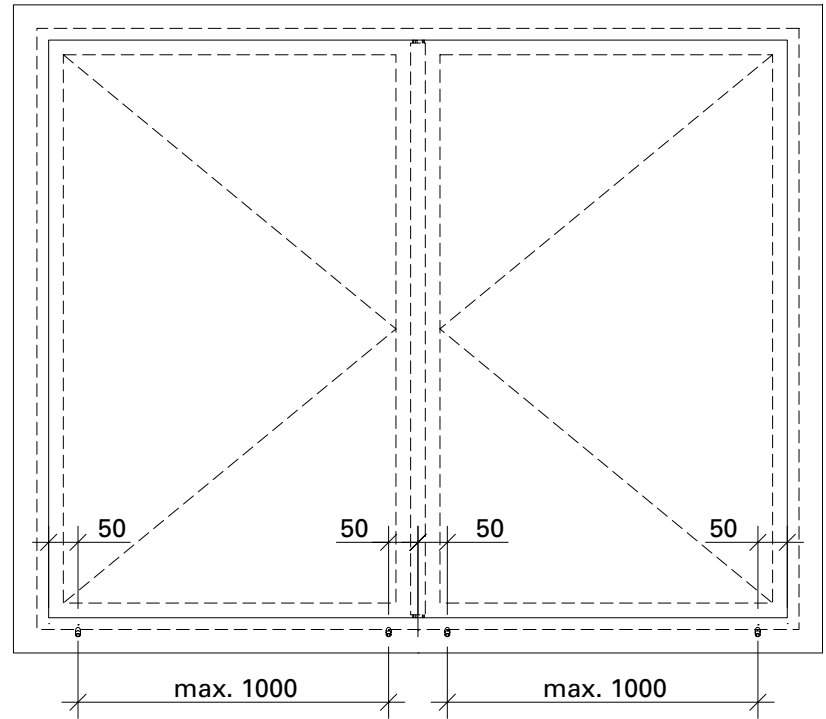
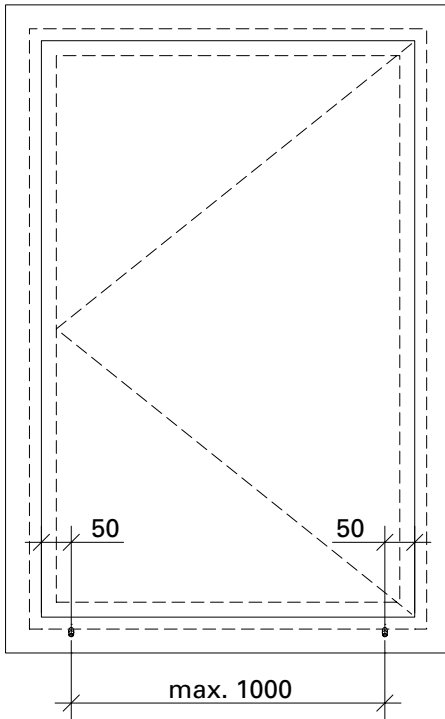

Versetzen der
 Wasserablauf-Tüllen 450.045

1. Bohrung $\varnothing 8$ mm mit Bohrlehre 499.103
2. Loch mit Korrosionsschutzfarbe behandeln
3. Ablauf-Tülle mit Kleber bestreichen
4. Einsetzen der Ablauf-Tülle mit Setzwerkzeug 499.104
5. Aussenseite abdichten 450.106

Montage des douilles
 d'écoulement 450.045

1. Perçage $\varnothing 8$ mm avec gabarit de perçage 499.103
2. Traiter le trou avec un enduit antirouille
3. Mettre la colle sur la douille
4. Pose de la douille avec outil de pose 499.104
5. Etanchéifier la face extérieure 450.106

Positioning draining pipe
 450.045

1. Drill 8mm \varnothing hole using drilling jig 499.103
2. Apply anti-corrosion paint to hole
3. Coat draining pipe with adhesive
4. Place draining pipe in position using mounting tool 499.104
5. Seal outside 450.106

Anordnung und Einbau
 Flügelfalzprofil 407.090
 Rahmen

Disposition et montage
 Profilé de feuillure de vantail 407.090
 Cadre

Arrangement and installation
 Vent rebate profile 407.090
 Frame

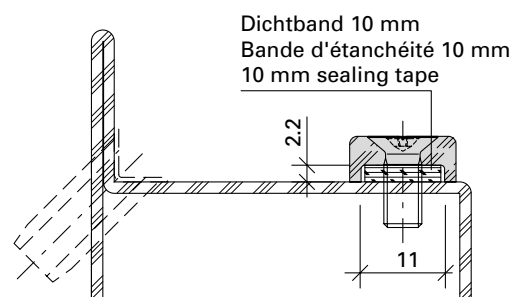
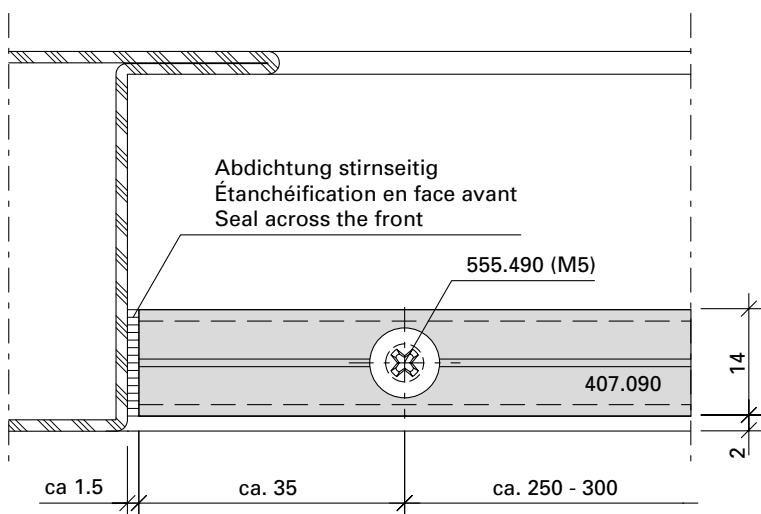
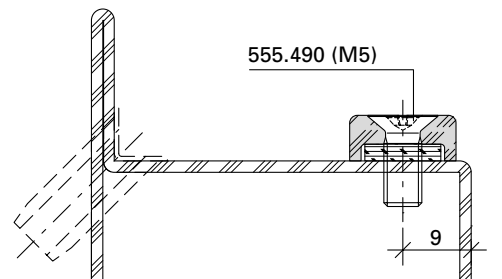
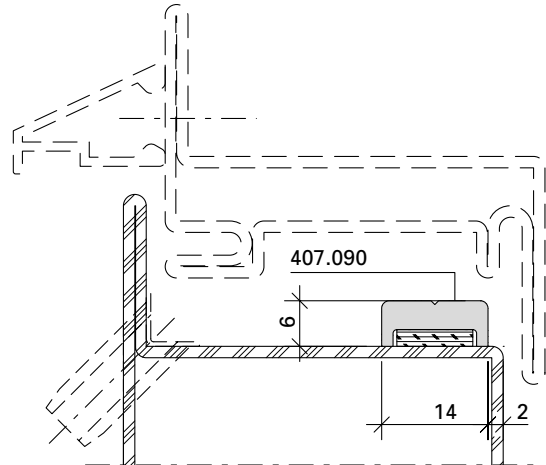
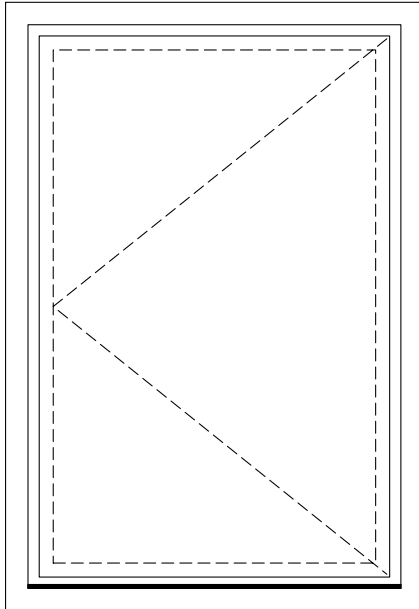

Glasfalzbelüftung
 Fensterflügel

Aération des feuillures à verre
 Vantail de fenêtre

Glazing rebate ventilation
 Window vent

Blindnietmutter M8 Stahl verzinkt
 mit kleinem Senkkopf
 Écrou borgne à rivet M8 en
 acier galvanisé à petite tête conique
 Blind rivet nut M8 galvanised steel
 with small countersunk head

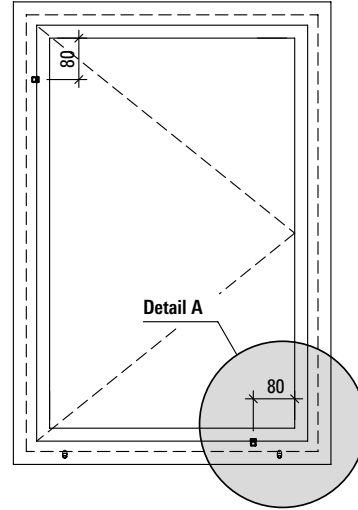
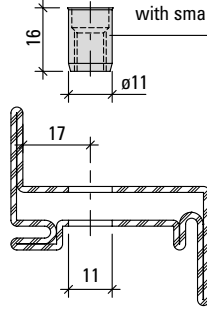
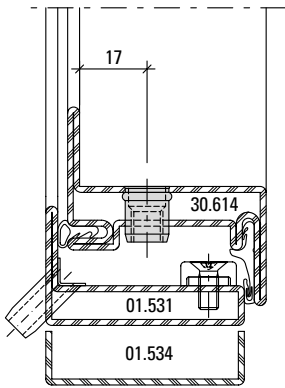

Detail A

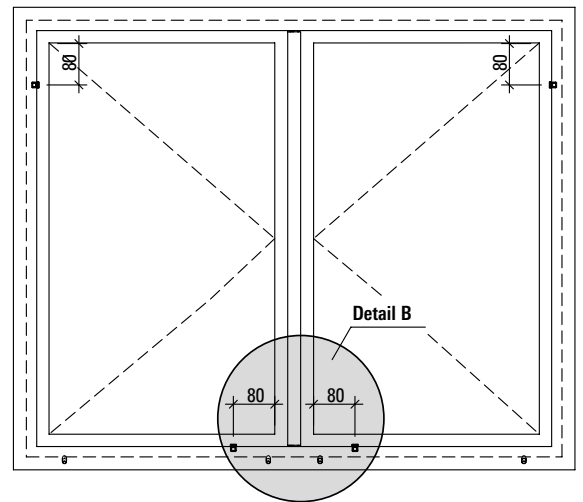
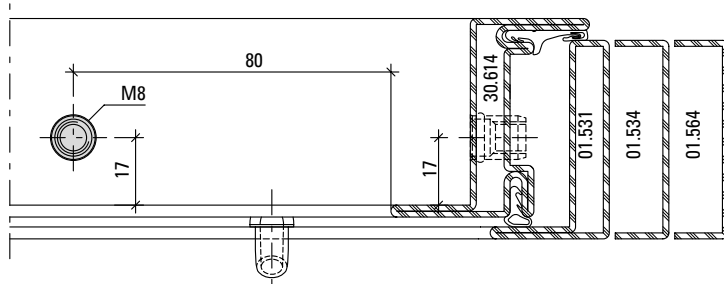

Detail B

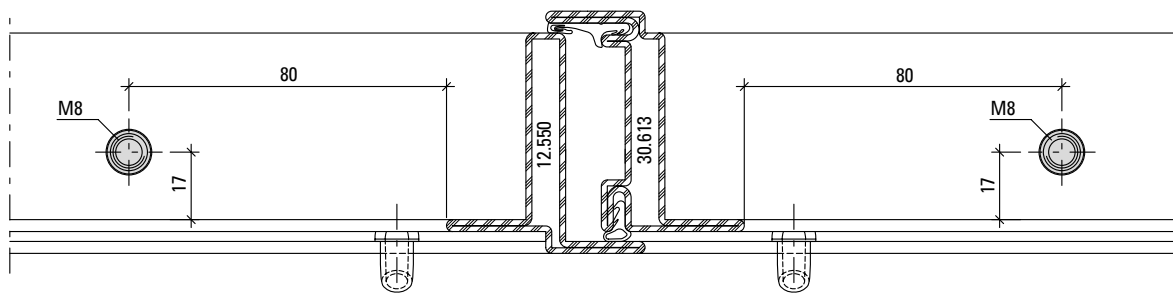

Glasfalzbelüftung
Fensterprosse

Aération des feuillures à verre

Glazing rebate ventilation

C-C

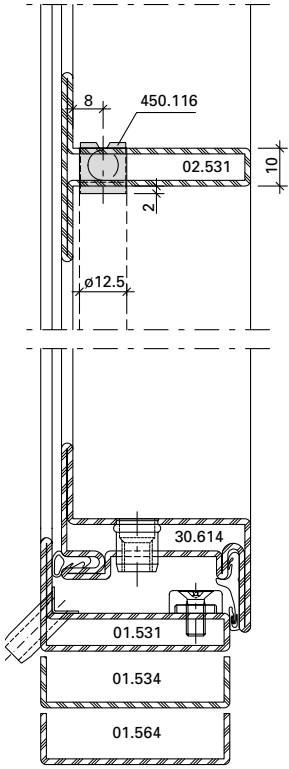

Alternative C-C

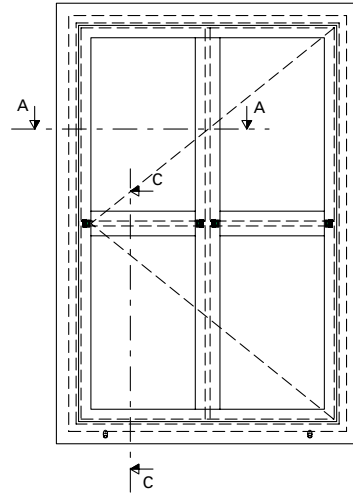
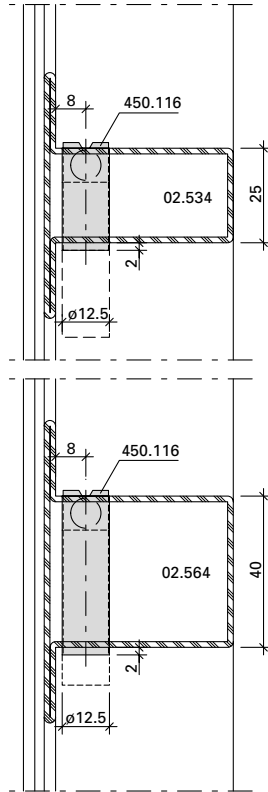

A-A

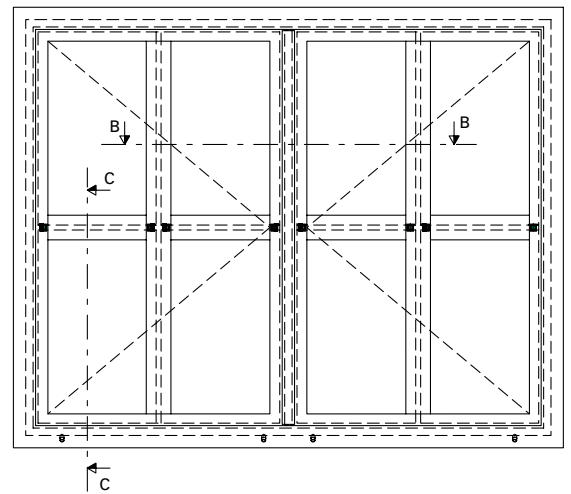
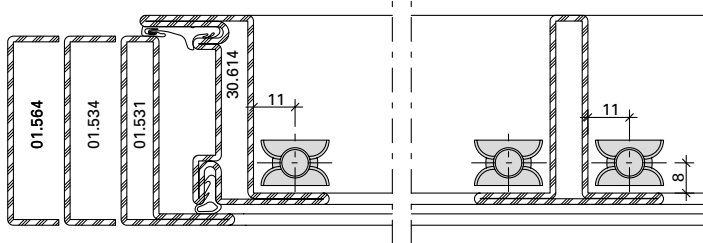

B-B

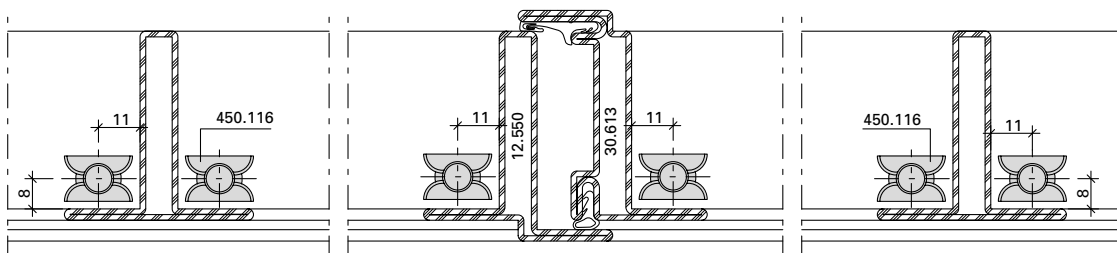

Verdeckt liegende Glasfalzbelüftung
 Festverglasung mit
 Trockenverglasung/ Nassverglasung

Aération non visible des feuillures
 à verre pour vitrage fixe avec
 vitrage à sec/ vitrage à mastic

Concealed glazing rebate ventilation
 Fixed glazing with dry glazing/sealing

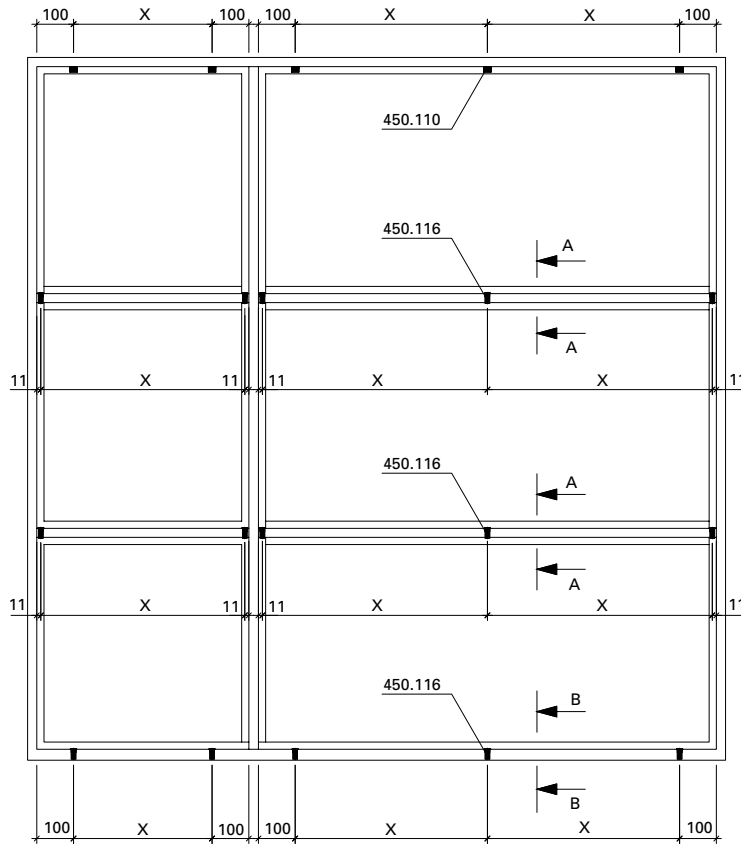

X = Nach Absprache Glaslieferant
 X = Selon fournisseur de verre
 X = As specified with the glass supplier

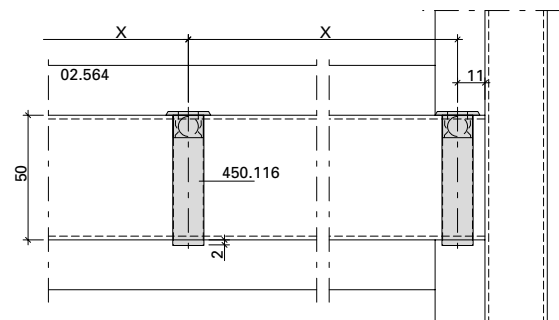
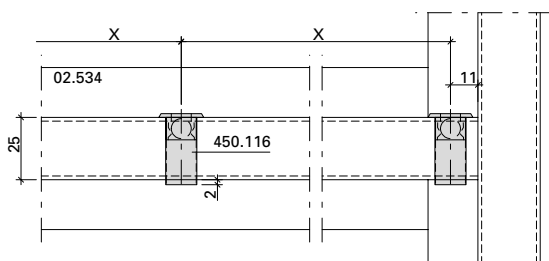
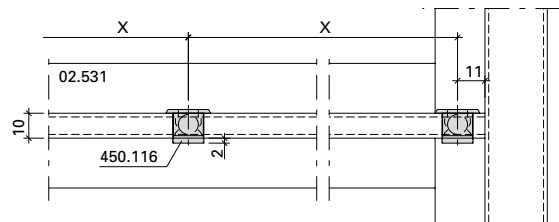
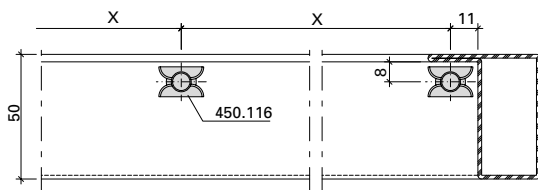
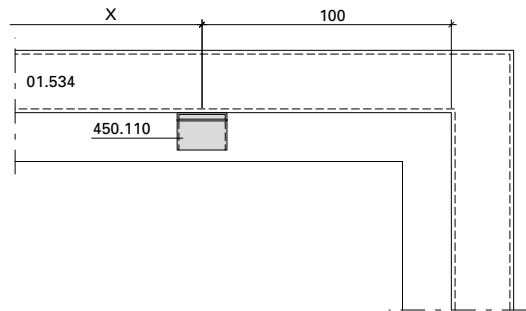
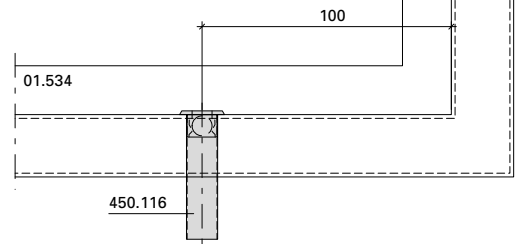

Verdeckt liegende Glasfalzbelüftung
 Festverglasung mit
 Trockenverglasung/ Nassverglasung

Aération non visible des feuillures
 à verre pour vitrage fixe avec
 vitrage à sec/ vitrage à mastic

Concealed glazing rebate ventilation
 Fixed glazing with dry glazing/sealing

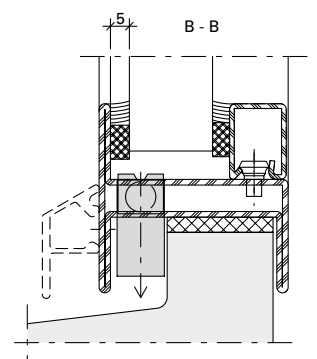
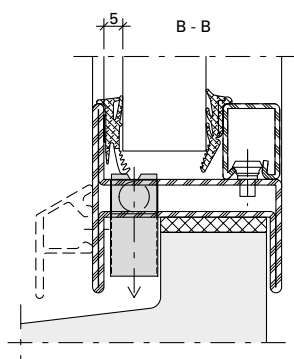
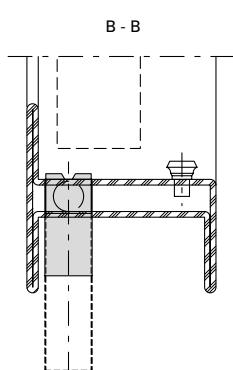
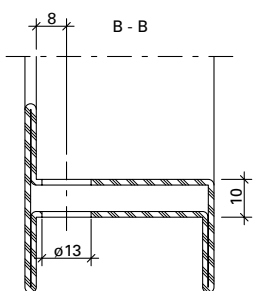
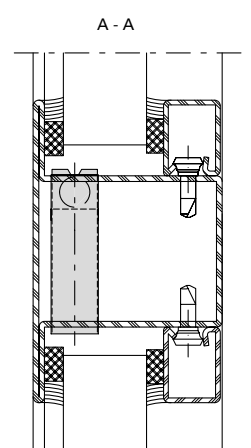
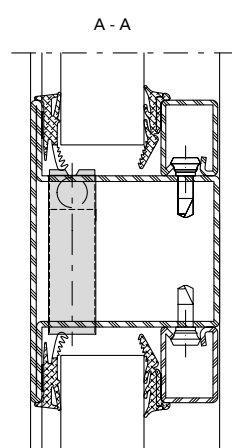
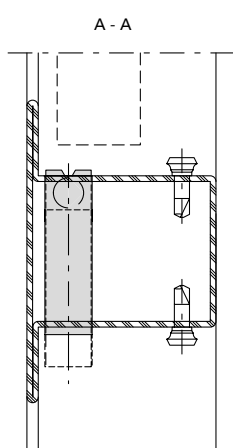
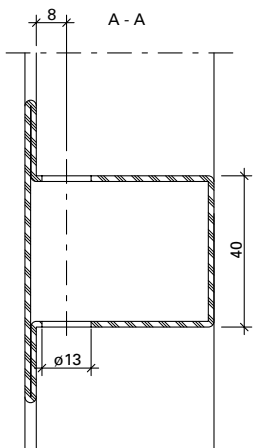
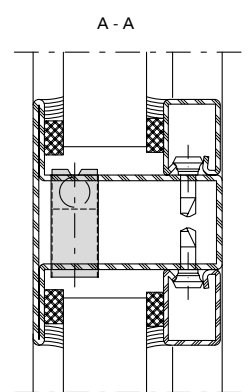
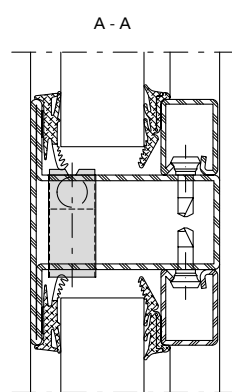
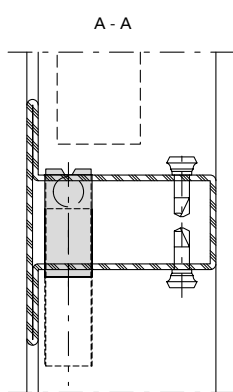
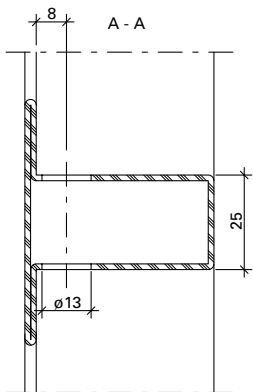
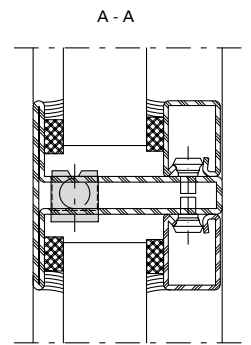
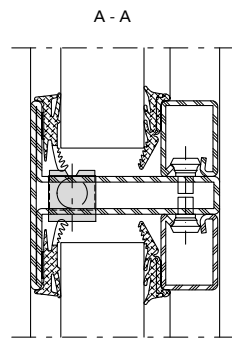
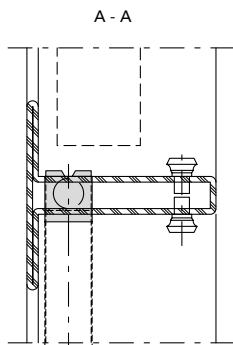
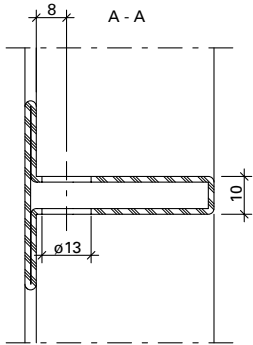

Montage-Reihenfolge
 Glasfalzbelüftung 450.116
 Festverglasung

Montage
 Feuillures à verre 450.116
 Vitrage fixe

Installation
 Glazing rebate ventilation 450.116
 Fixed glazing

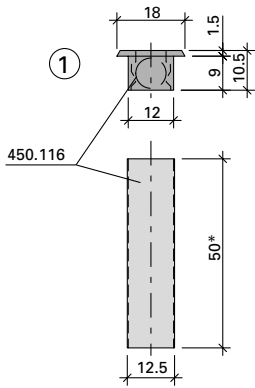

* entsprechend Profilbreite zu kürzen
 à raccourcir selon largeur de profilé
 to shorten according to profile width

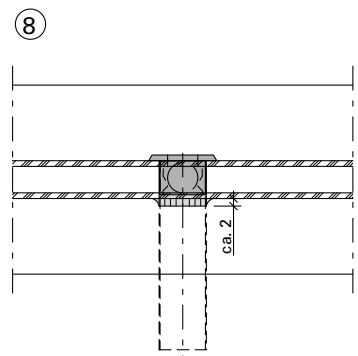
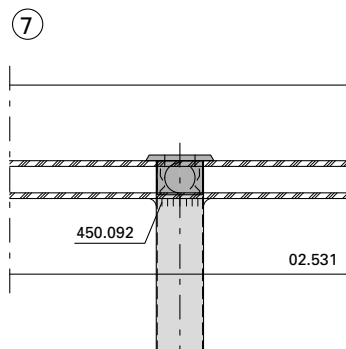
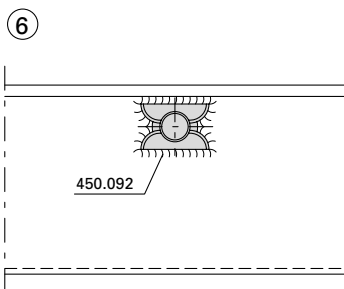
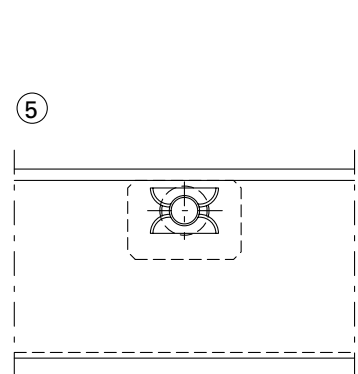
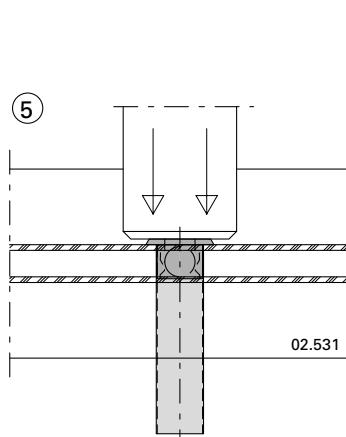
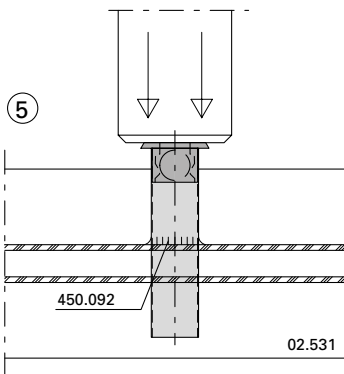
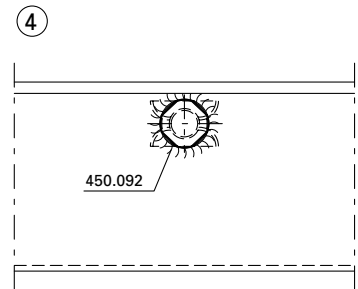
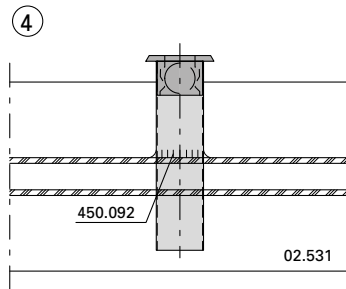
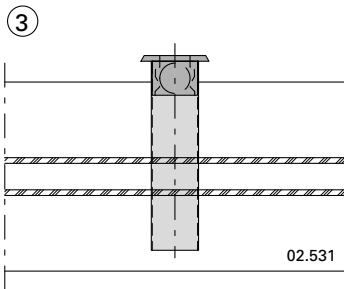
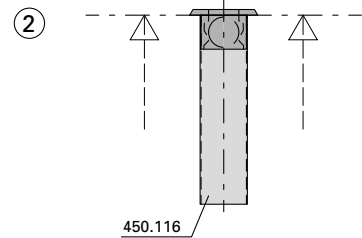

Verdeckt liegende Glasfalzbelüftung
 Festverglasung
 Winkel für Glasfalzbelüftung 450.110
 oben

Aération non visible des feuillures
 à verre pour vitrage fixe avec
 Equerres pour aération des feuillures
 à verre 450.110 en haut

Concealed glazing rebate ventilation
 Fixed glazing
 Angle for glazing rebate ventilation
 450.110 top

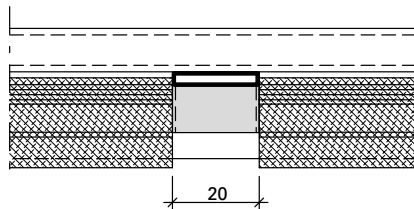
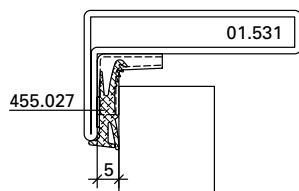
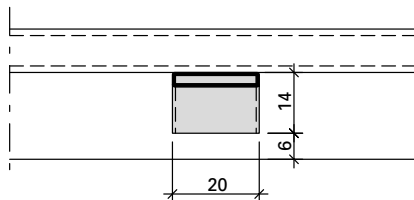
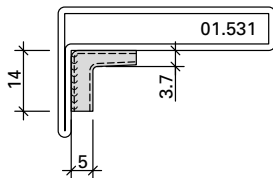
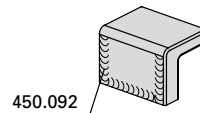
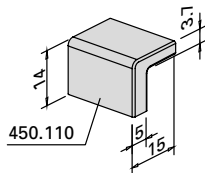

Trockenverglasung
 Vitrage à sec
 Dry glazing

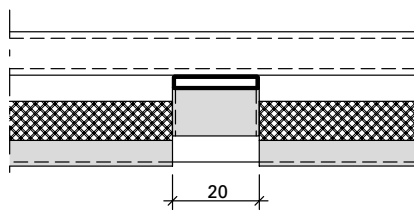
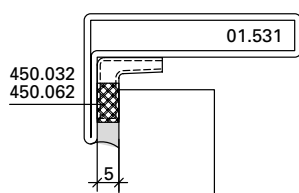

Nassverglasung
 Vitrage à mastic
 Glazing with sealing

Einbau Dichtung 455.000
 in Fensterflügel

Montage joint 455.000 dans le
 vantail de fenêtre

Installation of weatherstrip 455.000
 in the window vent

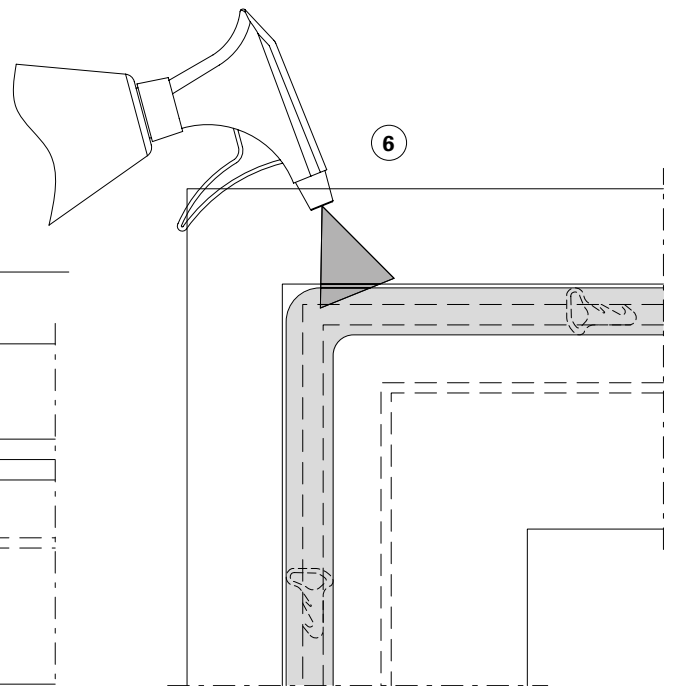
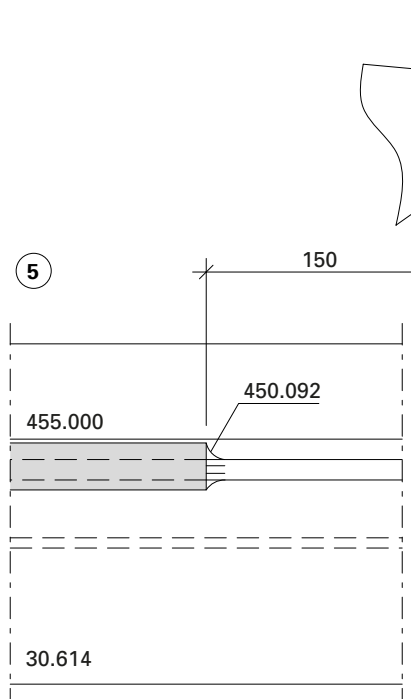
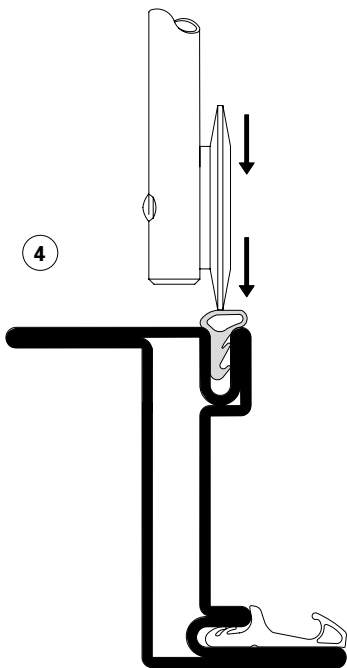
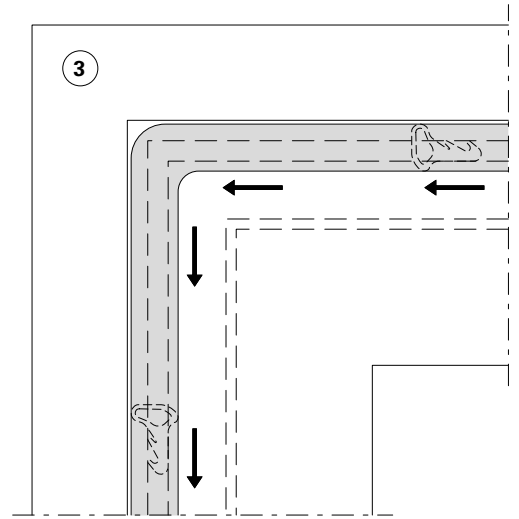
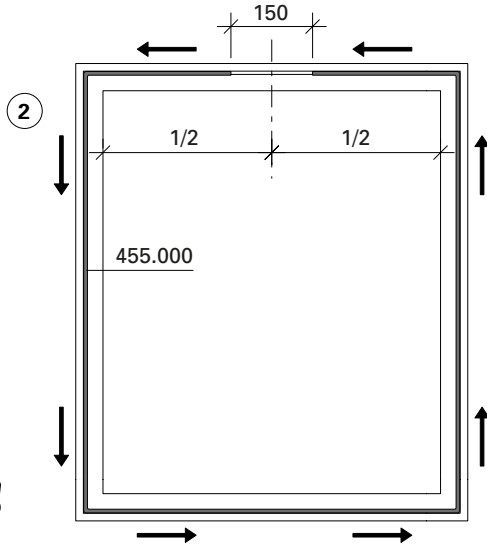
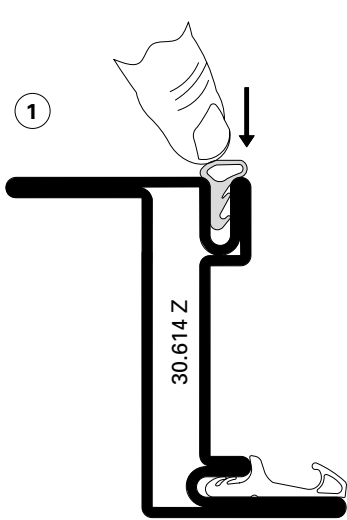

**Einbau Dichtung 455.000
in Fensterflügel**

1. Dichtung 455.000 von Hand in die Profildichtungsnaht eindrücken.
2. Bei Rahmenmitte oben beginnend Dichtung umlaufend einsetzen (Freistellung von 150 mm einhalten).
3. Dichtung wird im Eckbereich umlaufend geführt.
4. Dichtung mittels Dichtungsroller gleichmäßig tief in die Profildichtungsnaht eindrücken.
5. Dichtung stirnseitig mit Dichtmasse 450.092 abdichten.
6. Dichtung mit Gleitmittel besprühen, in erster Linie auf Bandseite.

**Montage joint 455.000 dans le
vantail de fenêtre**

1. Enfoncer le joint 455.000 à la main dans la rainure du joint profilé.
2. Mettre en place sur tout le pourtour en commençant en haut au milieu du cadre (Respecter la mise à nu de 150 mm).
3. Le joint passe sur tout l'angle.
4. Presser le joint profondément et de manière homogène dans la rainure du joint profilé au moyen de la roulette à joint.
5. Étanchéifier le joint en face avant avec de la pâte d'étanchéité 450.092
6. Vaporiser le joint avec du lubrifiant, en premier lieu côté paumelle.

**Installation of weatherstrip 455.000
in the window vent**

1. Press weatherstrip 455.000 into the profile weatherstrip groove by hand.
2. Starting from the top in the middle of the frame, insert all the way around (Maintain gap of 150 mm).
3. Weatherstrip is guided into the corner area all the way around.
4. Press the weatherstrip into the profile weatherstrip groove using a weatherstrip roller so it is of equal depth.
5. Seal weatherstrip at the ends with sealing compound 450.092.
6. Spray weatherstrip with lubricant mainly on the hinge side.

Einbau Dichtung 455.046
in Fensterflügel

Montage joint 455.046 dans le
vantail de fenêtre

Installation of weatherstrip 455.046
in the window vent

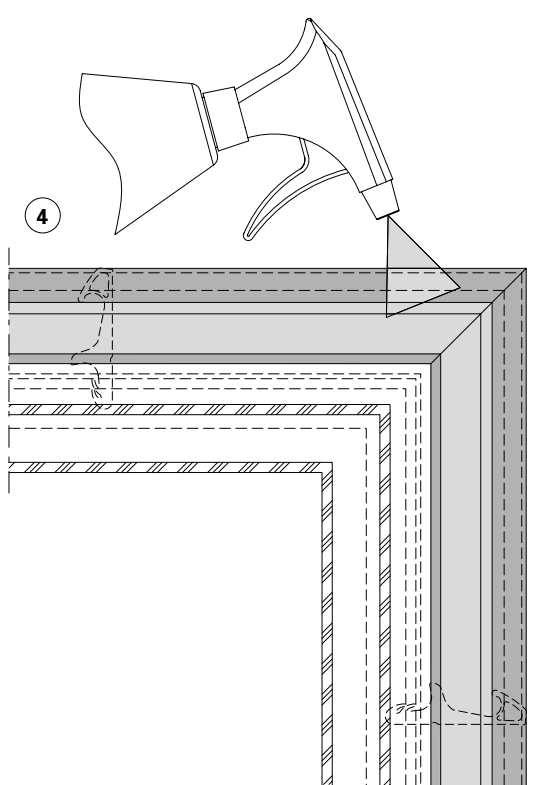
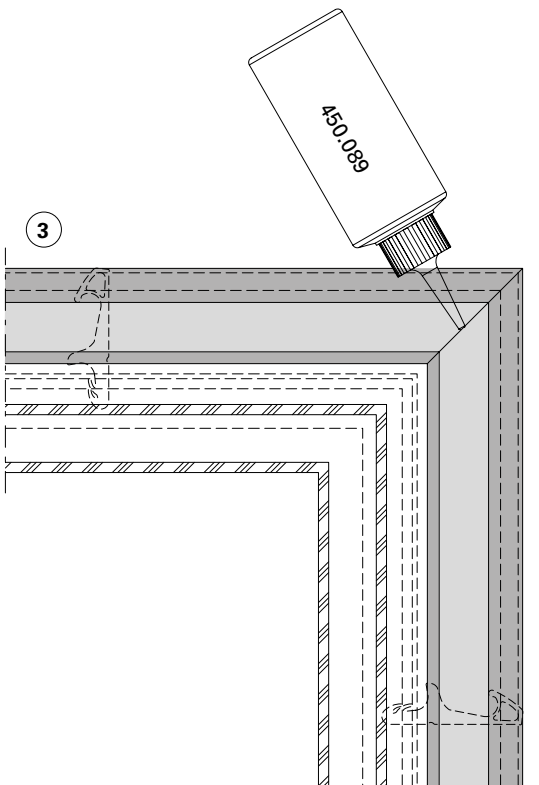
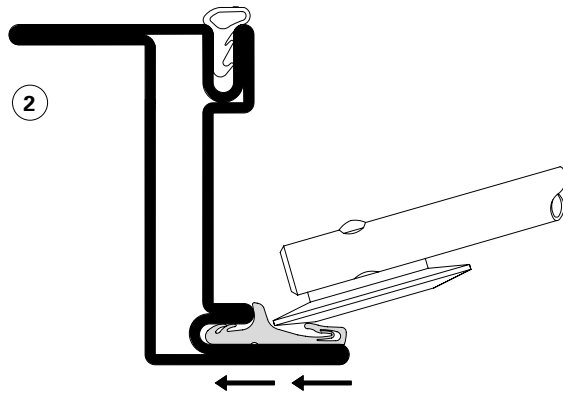
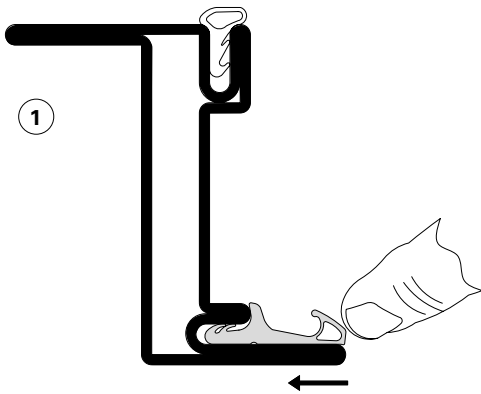

1. Dichtung 455.046 von Hand in die Profildichtungsgrube eindrücken.
2. Dichtung mittels Dichtungsroller gleichmässig tief in die Profildichtungsgrube eindrücken.
3. Dichtung im Eckbereich in Gehrung schneiden und mittels 450.089 verkleben.
4. Dichtung mit geeignetem Gleitmittel besprühen. In erster Linie auf Bandseite.

1. Enfoncer le joint 455.046 à la main dans la rainure du joint profilé.
2. Presser le joint profondément et de manière homogène dans la rainure du joint profilé au moyen de la roulette à joint.
3. Couper le joint en onglet dans l'angle et le coller avec 450.089.
4. Vaporiser du lubrifiant approprié sur le joint, avant tout côté paumelle.

1. Press weatherstrip 455.046 into the profile weatherstrip groove by hand.
2. Press the weatherstrip into the profile weatherstrip groove using a weatherstrip roller so it is of equal depth.
3. Mitre-cut the weatherstrip in the corner area and bond using 450.089.
4. Spray weatherstrip using suitable lubricant. Primarily on the hinge side.

Einbau Dichtungen im Stulpbereich
 oben und unten

Montage des joints fenêtre à deux
 vantaux partie en haut et en bas

Installation of weatherstrip in the
 double vent window zone at top
 and at bottom

Standflügel
 Vantail semi-fixe
 Secondary vent

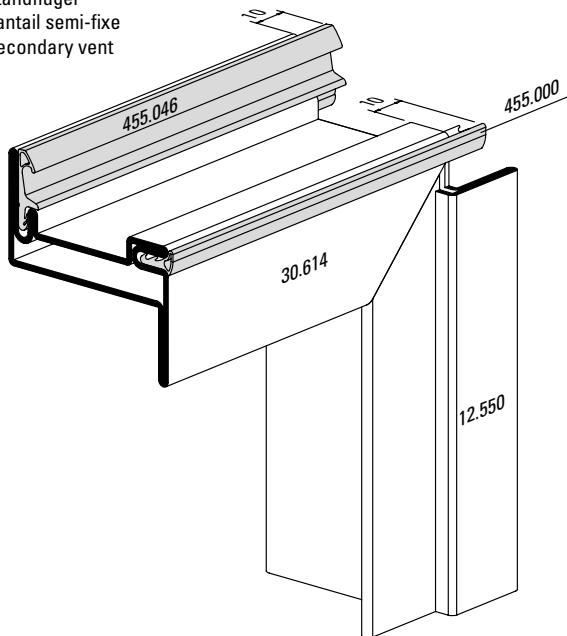

Gangflügel
 Vantail de service
 Access vent

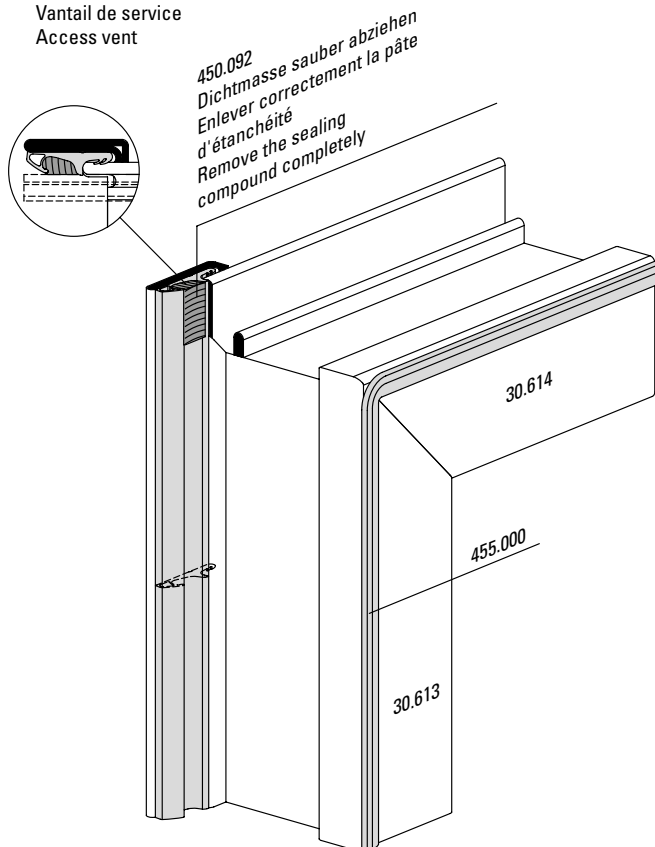

Gangflügel
 Vantail de service
 Access vent

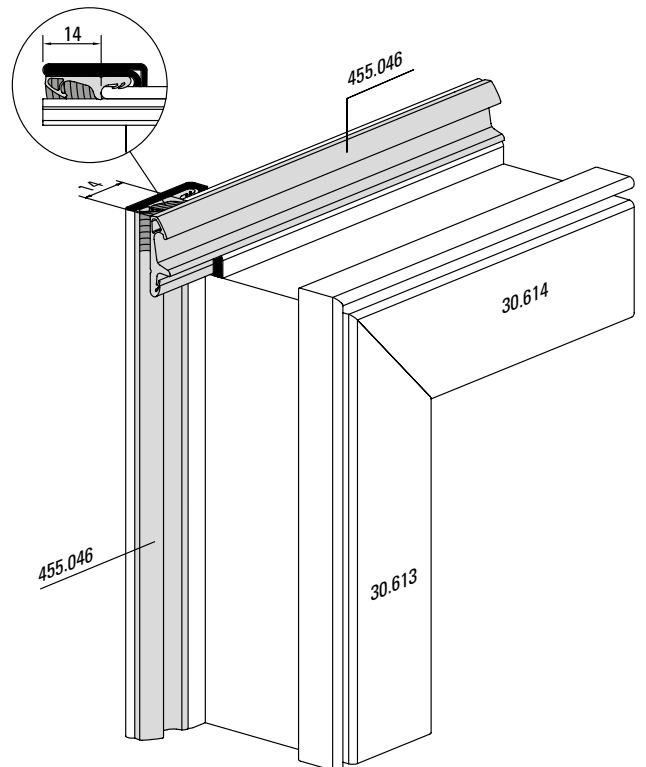

Einbau Dichtungstück 455.405
Stulpbereich

Montage embout d'étanchéité 455.405
pour fenêtre à deux vantaux

Installation weatherstrip 455.405
for double vent windows

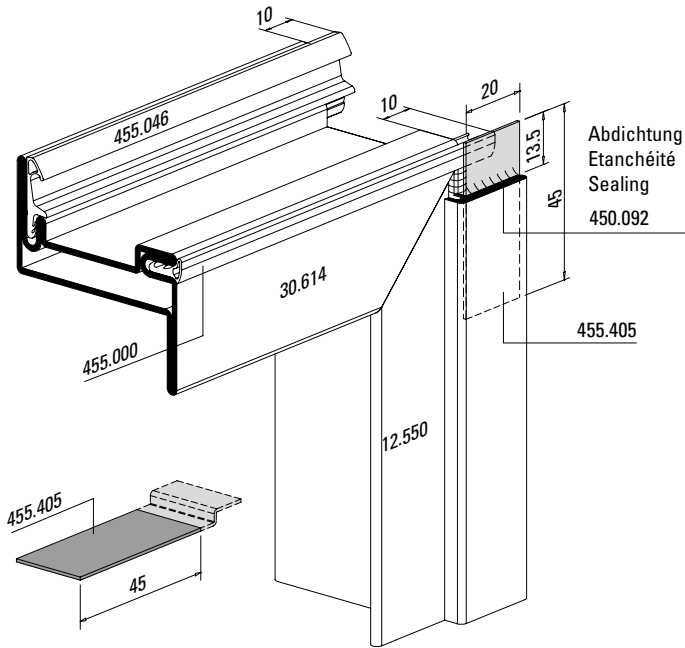

Standflügel
Vantail semi-fixe
Secondary vent

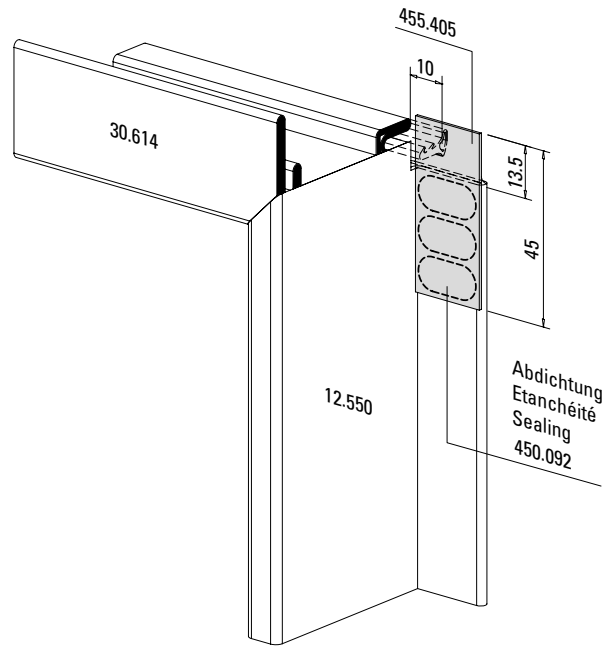

Verklotzen der Fenster

Calage des fenêtres

Glazing blocks of the windows

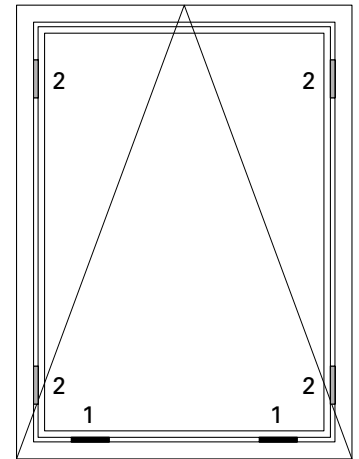
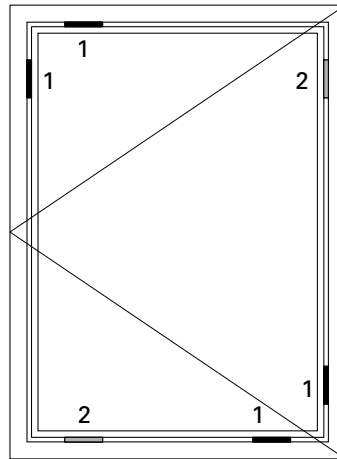
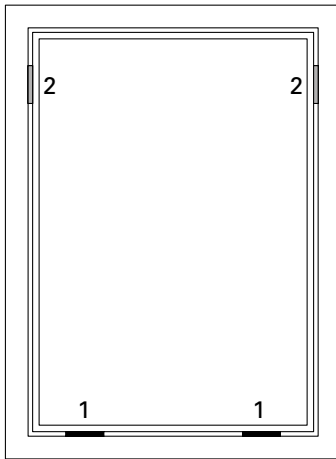

- | | |
|--|--|
| <p>1 </p> <p>Tragklotz
Cale d'assise
Support pad</p> | <p>2 </p> <p>Distanzklotz
Cale d'écartement
Spacer pad</p> |
|--|--|

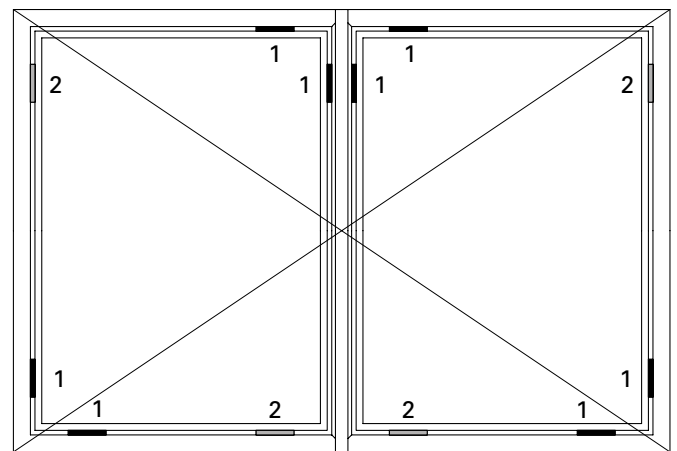

**Glaseinbau mittels
 Trockenverglasung**

**Pose des verres avec
 vitrage à sec**

**Glazing with
 dry glazing**

Abstände Glasleisten-Befestigungsknöpfe
 450.007/006/014

Distance entre boutons de fixation
 450.007/006/014

Distance between fastening studs
 450.007/006/014

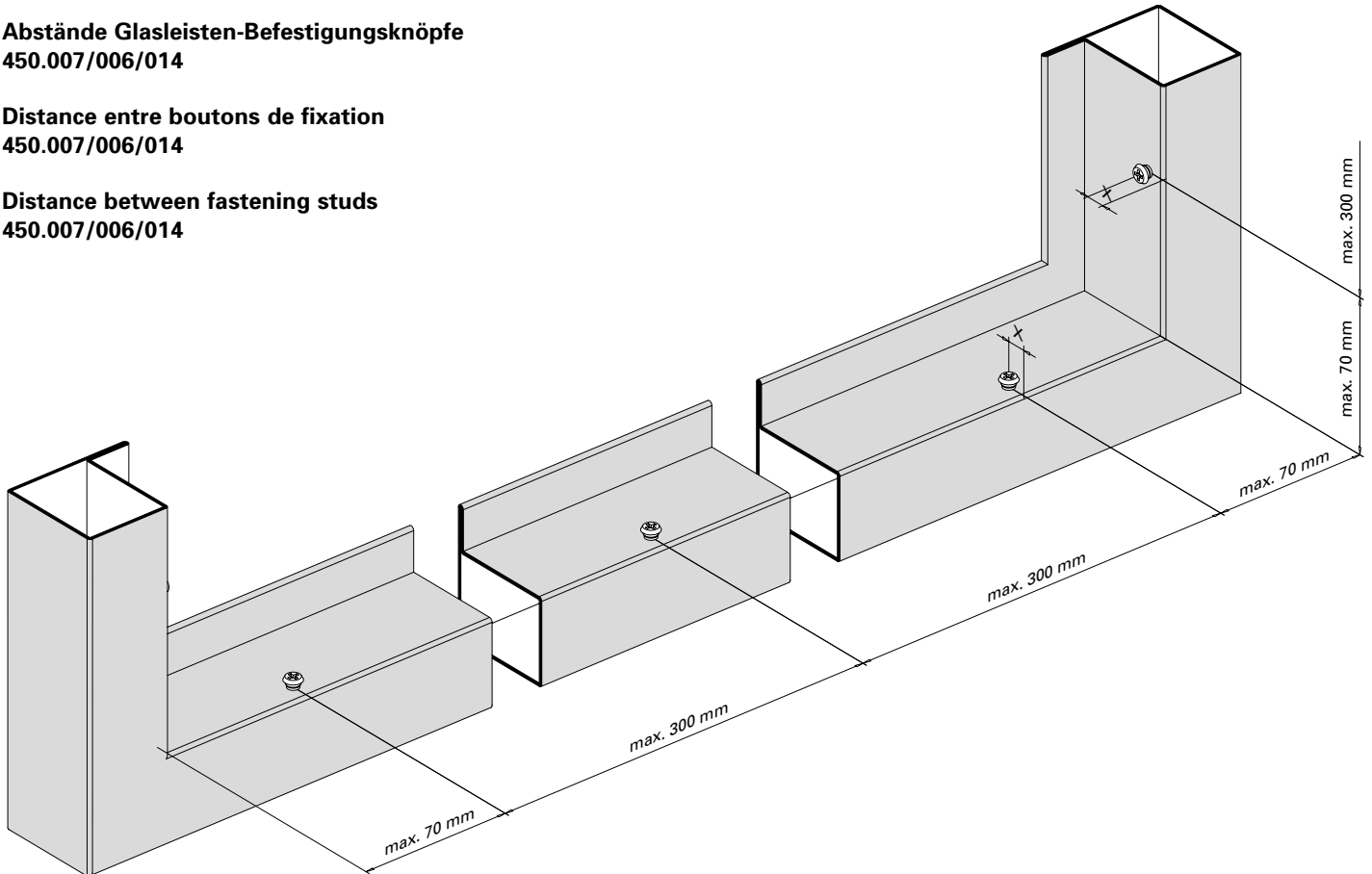

**Bestimmung der Dichtungen
 und des Falzspiels**

**Détermination des joints et les
 jeu de feuillure**

**Determining weatherstrips and
 rebate allowance**

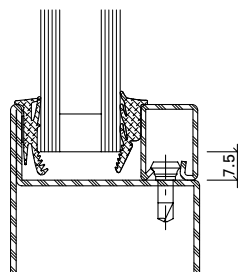
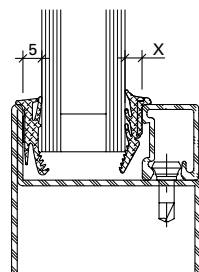
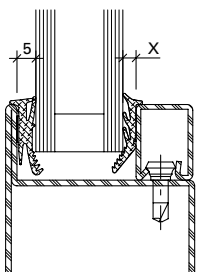

Stahl-Glasleiste
 Parclose en acier
 Steel glazing bead

Aluminium-Glasleiste
 Parclose en aluminium
 Aluminium glazing bead

Falzspiel
 Jeu de feuillure
 Rebate allowance

Ablaufschritte Glaseinbau

Procédure pour la pose des vitres

Steps in fitting glass panes

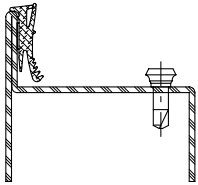

Dichtung 455.027 auf Profilanschlag kleben. Gehrungsecken verkleben.

Coller le joint 455.027 sur la battue du profilé. Onglet à coller.

Attach glazing weatherstrip 455.027 to section flange. Seal mitre.

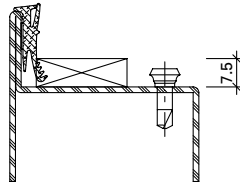

Glasklötze einsetzen. Dichtung im Bereich der unteren Glasklötze eventuell vorgängig ausklinken.

Poser les cales. Dans la zone des cales inférieures il peut être nécessaire de réaliser une encoche préalable.

Insert glazing blocks. If necessary, cut out notch in lower part of glazing weatherstrip beforehand.

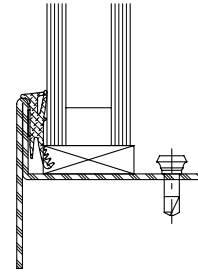

Glaselement (Füllelement) einsetzen und verklotzen.

Poser l'élément de vitrage (remplissage) et caler.

Insert glazing or infill panel and supports.

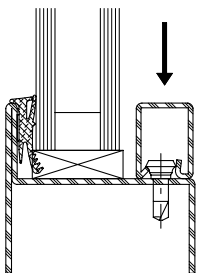

Glasleisten aufklipsen.

Clipser les parcloses.

Clip on glazing bead.

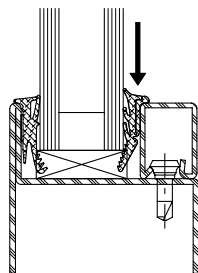

Innendichtung in Gehrung schneiden und in die Fuge eindrücken.

Le joint intérieure couper à onglet et presser dans la rainure.

Mitre glazing weatherstrip and press into the joint.

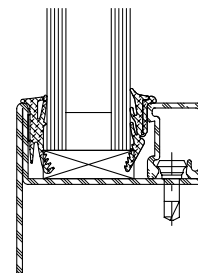

Situation mit Aluminium-Glasleiste
 Situation avec parclose en aluminium
 Situation with aluminium glazing bead

Bedingt durch verschiedene Toleranzen (Profile, Glasleisten, Anordnung Befestigungsknöpfe, Glasdichtung und Glaselemente) empfehlen wir, die Wahl der Glasdichtungen vorgängig an einem Element zu prüfen.

A cause des différentes tolérances (profilés, parcloses, disposition boutons de fixation, joint de vitrage et éléments vitrés) nous recommandons d'effectuer un essai préalable avec la joint de vitrage choisie sur un élément.

Owing to variations in the tolerances (profiled sections, glazing beads, layout of coupling studs, glazing weatherstrip and glazing) it is advisable to check your choice of glazing weatherstrips on an infill panel beforehand.

Glaseinbau mittels Nassverglasung

Pose des verres avec vitrage à mastic

Glazing with glazing with sealing

Abstände Glasleisten-Befestigungsknöpfe
 450.007/006/014

Distance entre boutons de fixation
 450.007/006/014

Distance between fastening studs
 450.007/006/014

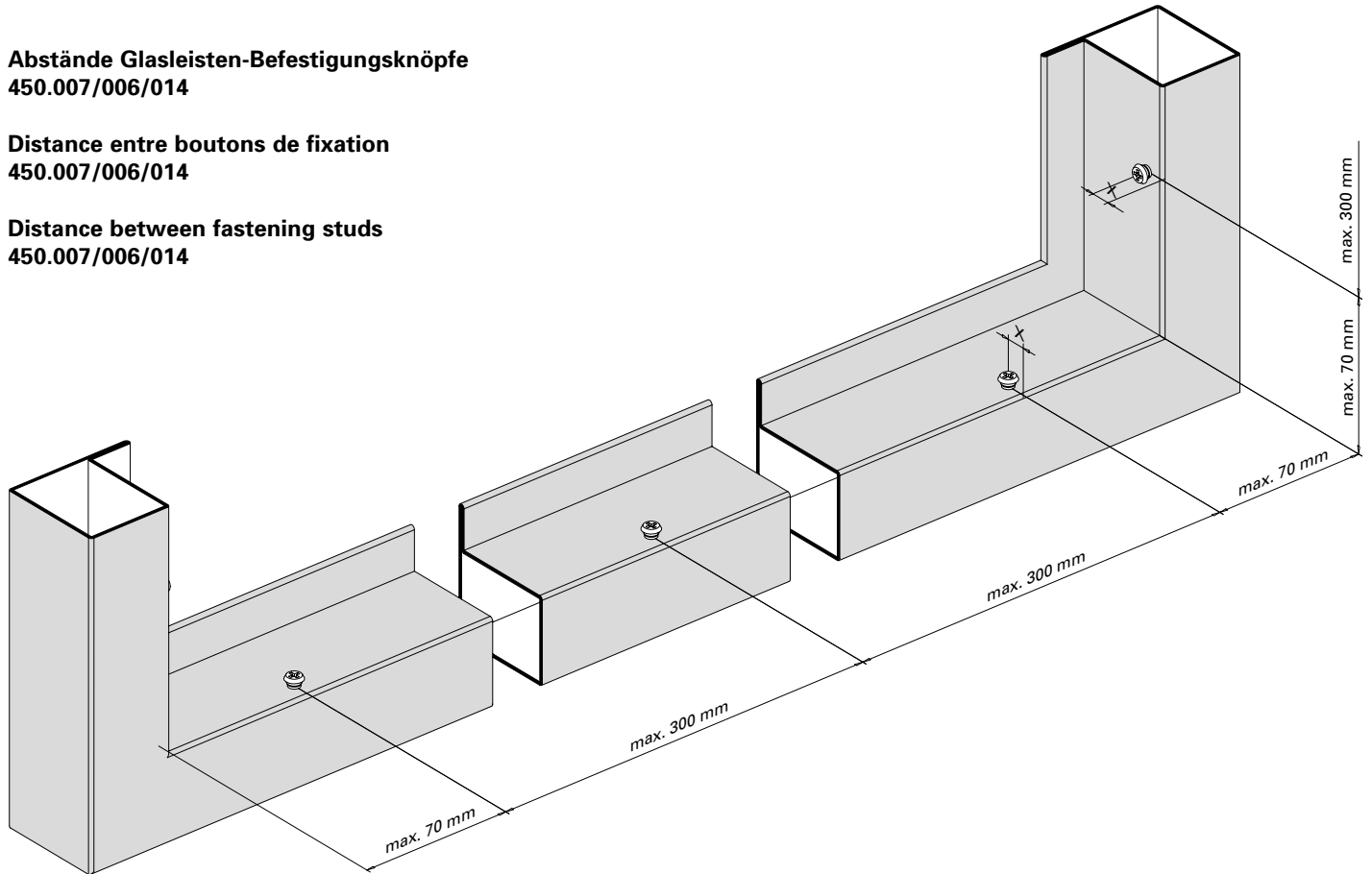

Bestimmung der Distanzbänder und des Falzspiels

Détermination des bandes d'écartement et les jeu de feuillure

Determining packing strips and rebate allowance

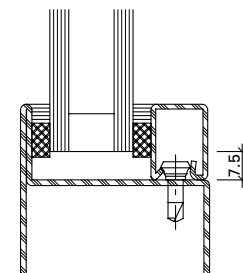
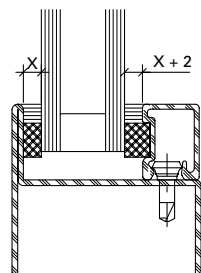
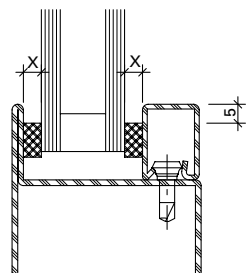

Stahl-Glasleiste
 Parclose en acier
 Steel glazing bead

Aluminium-Glasleiste
 Parclose en aluminium
 Aluminium glazing bead

Falzspiel
 Jeu de feuillure
 Rebate allowance

X:
 Distanzbanddicke =
 Fugenbreite

X:
 Epaisseur de la bande d'écartement =
 Largeur de joint

X:
 Thickness of packing strip =
 Width of joint

X + 2:
 Distanzbanddicke =
 Fugenbreite + 2 mm

X + 2:
 Epaisseur de la bande d'écartement =
 Largeur de joint + 2 mm

X + 2:
 Thickness of packing strip =
 Width of joint + 2 mm

Ablaufschritte Glaseinbau

Procédure pour la pose des vitres

Steps in fitting glass panes

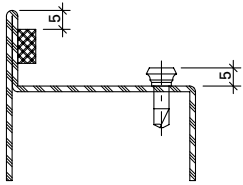

Distanzband auf Profillappen kleben
 Coller la bande d'écartement sur la battue du profilé
 Attach packing strip to section flange

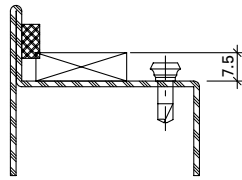

Glasklotz einsetzen
 Poser la cale
 Insert glazing block

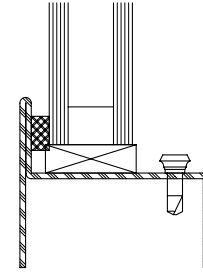

Glaselement einsetzen
 Poser l'élément de vitrage
 Insert glass pane

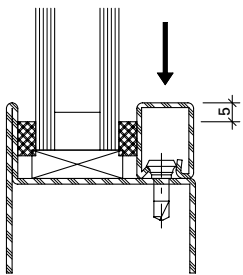

Glasleiste mit aufgeklebtem Distanzband montieren
 Clipser la parclose avec la bande d'écartement collée
 Clip the glazing bead with the glued-on packing strip on one side

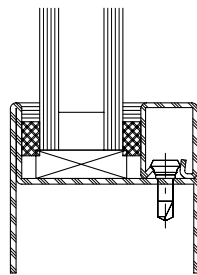

Fugen innen und aussen versiegeln
 Sceller le joint intérieur et extérieur
 Seal the joint inside and outside

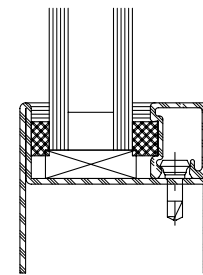

Situation mit Aluminium-Glasleiste
 Situation avec parclose en aluminium
 Situation with aluminium glazing bead

Bedingt durch verschiedene Toleranzen (Profile, Glasleisten, Anordnung Befestigungsknöpfe, Distanzbänder und Glaselemente) empfehlen wir, die Wahl der Distanzbänder vorgängig an einem Element zu prüfen.

A cause des différentes tolérances (profilés, parcloses, disposition boutons de fixation, bandes de distance et éléments vitrés) nous recommandons d'effectuer un essai préalable avec la bande de distance choisie sur un élément.

Owing to variations in the tolerances (profiled sections, glazing beads, layout of coupling studs, packing strips and glazing) it is advisable to check your choice of packing strips on an infill panel beforehand.

Betreffend Fugendimensionierung und Fugenausbildung verweisen wir auf die Richtlinien der Glashersteller.

En ce qui concerne le dimensionnement et la formation des joints nous renvoyons aux directives du fabricant de verre.

Referring to joint dimensioning and joint form we refer you to the guidelines of glass manufacturer.

Glaseinbau mittels Nassverglasung

Pose des verres avec vitrage à mastic

Glazing with glazing with sealing

Abstände Befestigungsfeder 450.022 und Befestigungsknöpfe 450.020

Distance entre ressort de fixation 450.022 et boutons de fixation 450.020

Distance between fastening springs 450.022 and fastening studs 450.020

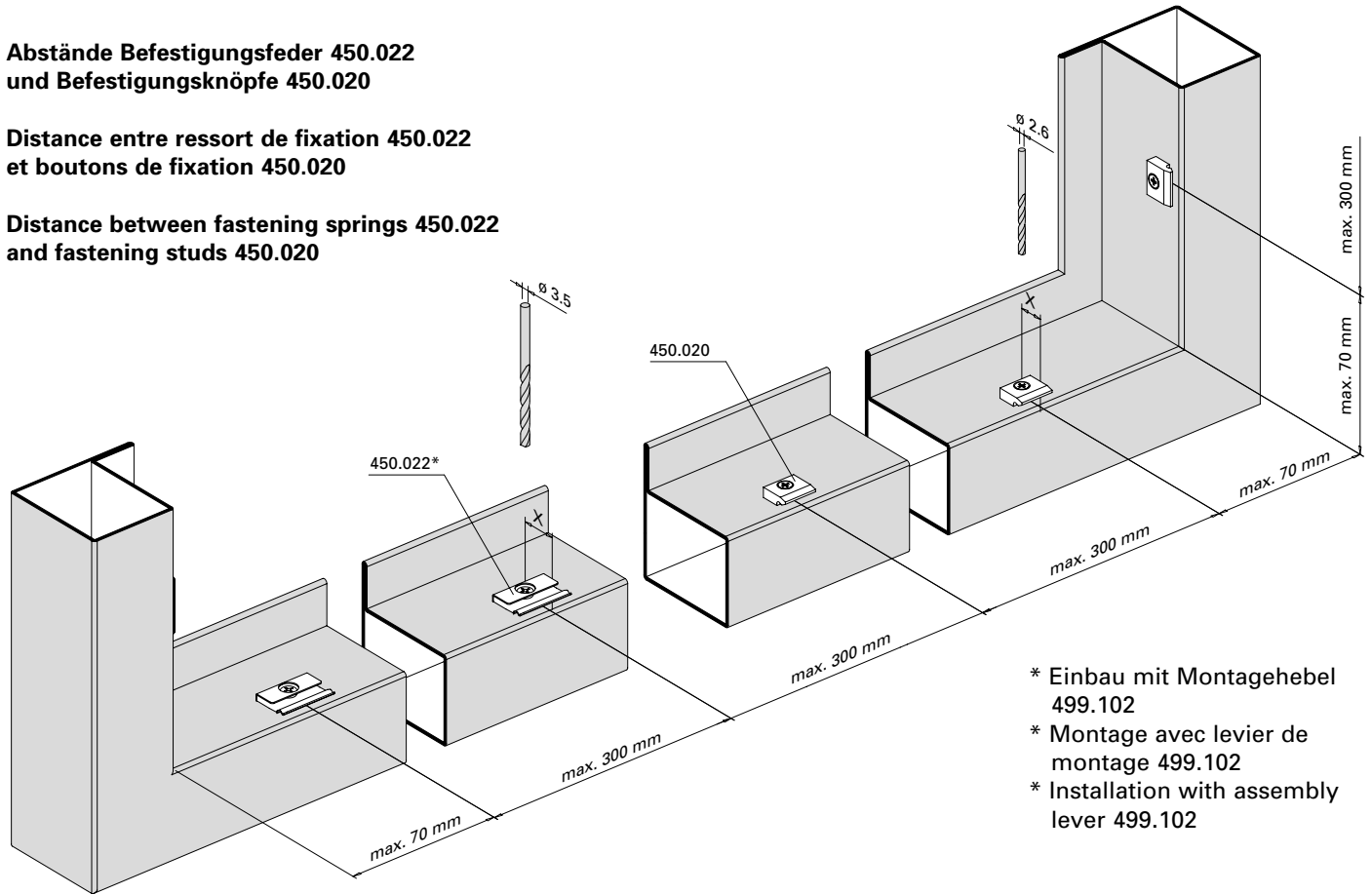

- * Einbau mit Montagehebel 499.102
- * Montage avec levier de montage 499.102
- * Installation with assembly lever 499.102

Bestimmung der Distanzbänder und des Falzspiels

Détermination des bandes d'écartement et les jeu de feuillure

Determining packing strips and rebate allowance

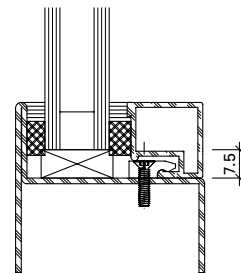
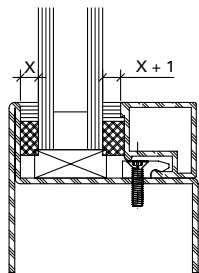
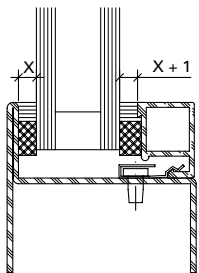

Befestigungsfeder 450.022
 Ressort de fixation 450.022
 Fastening spring 450.022

Knopf 450.020 / Schraube 450.021
 Bouton 450.020 / Vis 450.021
 Stud 450.020 / Screw 450.021

Falzspiel
 Jeu de feuillure
 Rebate allowance

X:
 Distanzbanddicke =
 Fugenbreite

X:
 Epaisseur de la bande d'écartement =
 Largeur de joint

X:
 Thickness of packing strip =
 Width of joint

X + 1:
 Distanzbanddicke =
 Fugenbreite + 1 mm

X + 1:
 Epaisseur de la bande d'écartement =
 Largeur de joint + 1 mm

X + 1:
 Thickness of packing strip =
 Width of joint + 1 mm

Ablaufschritte Glaseinbau

Procédure pour la pose des vitres

Steps in fitting glass panes

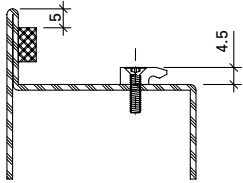

Distanzband auf Profillappen kleben
 Coller la bande d'écartement sur la battue du profilé
 Attach packing strip to section flange

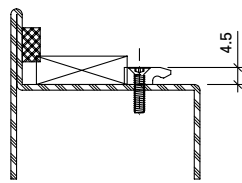

Glasklotz einsetzen
 Poser la cale
 Insert glazing block

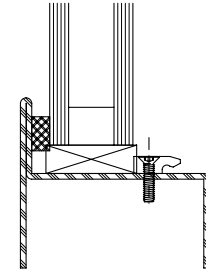

Glaselement einsetzen
 Poser l'élément de vitrage
 Insert glass pane

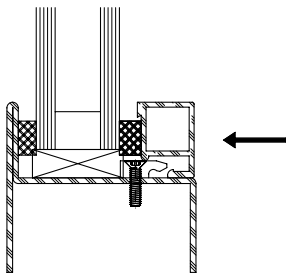

Glasleiste mit aufgeklebtem Distanzband montieren
 Clipser la parclose avec la bande d'écartement collée
 Clip the glazing bead with the glued-on packing strip on one side

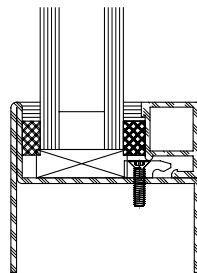

Fugen innen und aussen versiegeln
 Sceller le joint intérieur et extérieur
 Seal the joint inside and outside

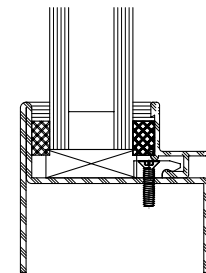

Situation mit Aluminium-Glasleiste
 Situation avec parclose en aluminium
 Situation with aluminium glazing bead

Bedingt durch verschiedene Toleranzen (Profile, Glasleisten, Anordnung Befestigungsknöpfe, Distanzbänder und Glaselemente) empfehlen wir, die Wahl der Distanzbänder vorgängig an einem Element zu prüfen.

A cause des différentes tolérances (profilés, parcloses, disposition boutons de fixation, bandes de distance et éléments vitrés) nous recommandons d'effectuer un essai préalable avec la bande de distance choisie sur un élément.

Owing to variations in the tolerances (profiled sections, glazing beads, layout of coupling studs, packing strips and glazing) it is advisable to check your choice of packing strips on an infill panel beforehand.

Betreffend Fugendimensionierung und Fugenausbildung verweisen wir auf die Richtlinien der Glashersteller.

En ce qui concerne le dimensionnement et la formation des joints nous renvoyons aux directives du fabricant de verre.

Referring to joint dimensioning and joint form we refer you to the guidelines of glass manufacturer.

Massbezeichnungen

Dimensions cotées

Measurement descriptions

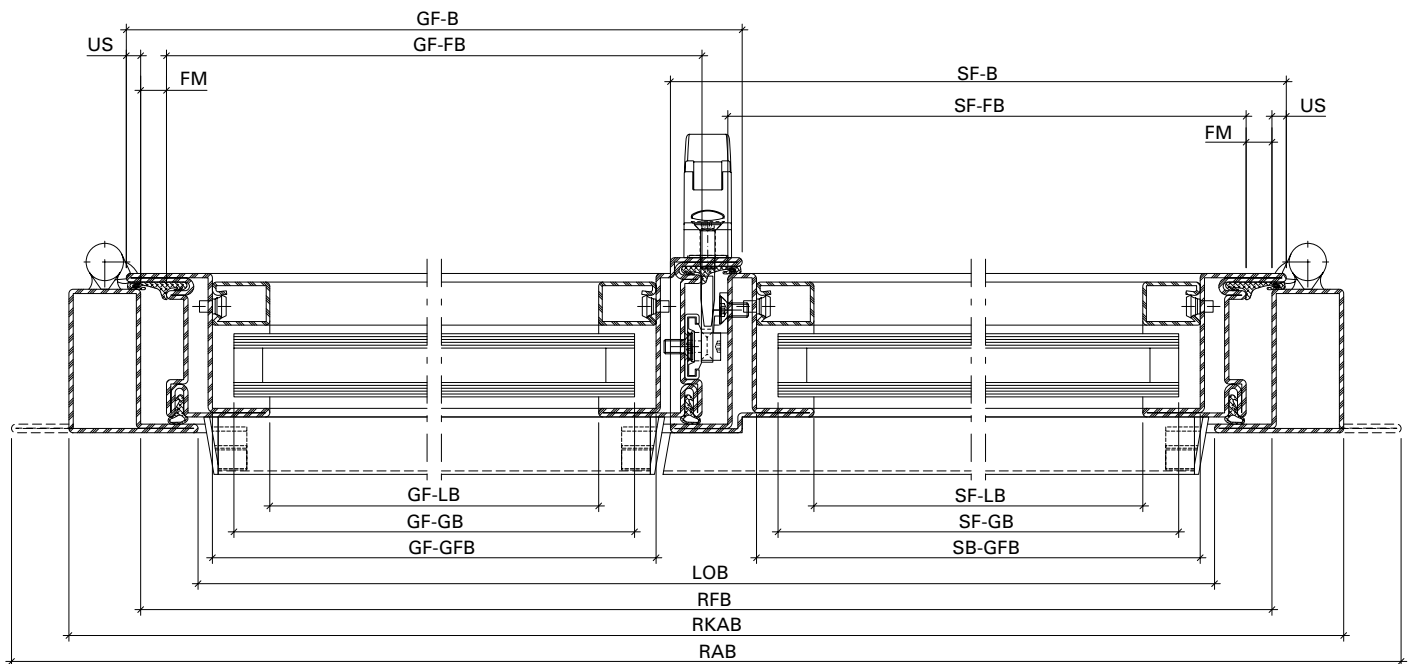
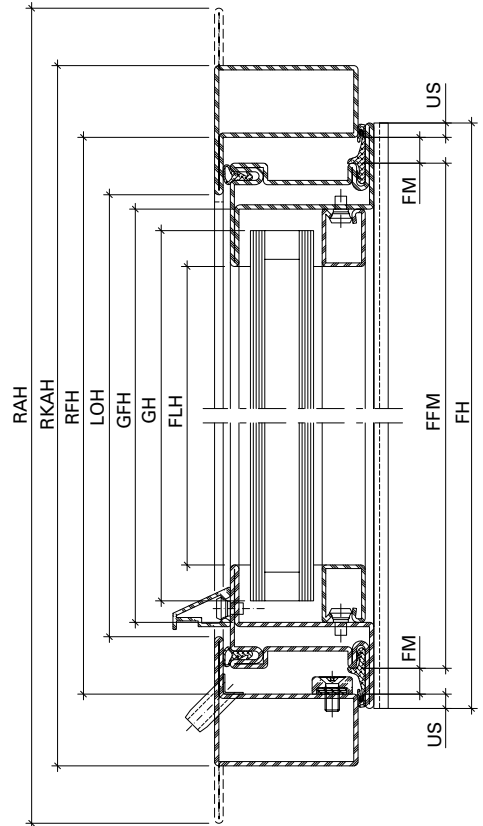
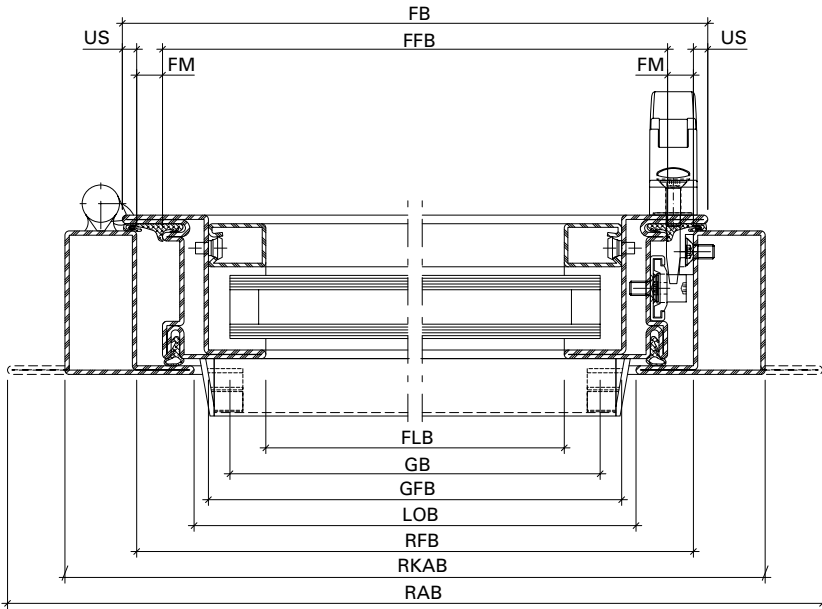

Massbezeichnungen		Dimensions cotées		Measurement descriptions	
US	Überschlag	US	Recouvrement	US	Overlap
FM	Falzmass	FM	Dimension de la feuillure	FM	Rebate
FH	Flügelhöhe	FH	Hauteur du vantail	FH	Vent height
FFH	Flügelfalzhöhe	FFH	Hauteur de feuillure du vantail	FFH	Vent rebate height
FLH	Flügel-Lichtmasshöhe	FLH	Hauteur vide lumière du vantail	FLH	Clear height dimension of vent
FB	Flügelbreite	FB	Largeur du vantail	FB	Vent width
FFB	Flügelfalzbreite	FFB	Largeur de feuillure du vantail	FFB	Vent rebate width
FLB	Flügel-Lichtmassbreite	FLB	Largeur vide lumière du vantail	FLB	Clear width dimension of vent
GH	Glashöhe	GH	Hauteur du verre	GH	Glass height
GFH	Glasfalzhöhe	GFH	Hauteur de feuillure du verre	GFH	Glazing rebate height
GB	Glasbreite	GB	Largeur du verre	GB	Glass width
GFB	Glasfalzbreite	GFB	Largeur de feuillure du verre	GFB	Glazing rebate width
LOH	Lichte Öffnungshöhe	LOH	Hauteur vide lumière	LOH	Clear opening height
RFH	Rahmenfalzhöhe	RFH	Hauteur de feuillure du dormant	RFH	Frame rebate height
RAH	Rahmnaussenhöhe	RAH	Hauteur extérieur du dormant	RAH	External frame height
LOB	Lichte Öffnungsbreite	LOB	Largeur vide lumière	LOB	Clear opening width
RFB	Rahmenfalzbreite	RFB	Largeur de feuillure du dormant	RFB	Frame rebate width
RAB	Rahmnaussenbreite	RAB	Largeur extérieur du dormant	RAB	External frame width
GF-B	Gangflügel-Breite	GF-B	Largeur du vantail de service	GF-B	Access vent width
GF-FB	Gangflügel-Falzbreite	GF-FB	Largeur de feuillure du vantail de service	GF-FB	Access vent rebate width
GF-LB	Gangflügel-Lichtmassbreite	GF-LB	Vide lumière du vantail de service	GF-LB	Clear width dimension of access vent
GF-GB	Gangflügel-Glasbreite	GF-GB	Largeur du verre du vantail de service	GF-GB	Glass width of access vent
GF-GFB	Gangflügel-Glasfalzbreite	GF-GFB	Largeur de feuillure du verre du vantail de service	GF-GFB	Glazing rebate width of access vent
SF-B	Standflügel-Breite	SF-B	Largeur du vantail semi-fixe	SF-B	Secondary vent width
SF-FB	Standflügel-Falzbreite	SF-FB	Largeur de feuillure du vantail semi-fixe	SF-FB	Rebate width of secondary vent
SF-LB	Standflügel-Lichtmassbreite	SF-LB	Vide lumière du vantail semi-fixe	SF-LB	Clear width dimension of secondary vent
SF-GB	Standflügel-Glasbreite	SF-GB	Largeur du verre du vantail semi-fixe	SF-GB	Glass width of secondary vent
SF-GFB	Standflügel-Glasfalzbreite	SF-GFB	Largeur de feuillure du verre du vantail semi-fixe	SF-GFB	Glazing rebate width of secondary vent
S-FM	Stulpflügel-Falzmass	S-FM	Dimension de la feuillure fenêtre à deux vantaux	S-FM	Double-vent rebate

Verarbeitungshinweise
Indications d'usage
Assembly instructions

Jansen Art'System
Jansen Art'System
Jansen Art'System

**Bedienungs-, Pflege- und
Wartungsanleitung siehe
Dokumentation 598.461**

**Instructions d'emploi,
d'entretien et de maintenance
voir documentation 598.468**

**Operating and maintenance
instructions see
documentation 598.467**



Jansen AG

Steel Systems
Industriestrasse 34
9463 Oberriet
Schweiz
jansen.com

JANSEN
Configure to Inspire