

VISS Basic Tragkonstruktion

Verarbeitung und Montage

Construction porteuse VISS Basic

Usinage et montage

VISS Basic supporting structure

Processing and assembly

Struttura portante VISS Basic

Lavorazione e montaggio

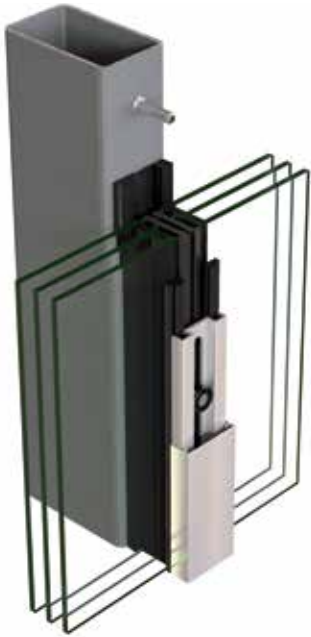

VISS Basic

Hochwärmegedämmte Vertikalfassade
Façade verticale à haute rupture de pont thermique
High thermally insulated vertical façade
Facciata verticale con elevato isolamento termico



VISS Basic SG / VISS Basic Semi SG

Ganzglasfassade (Structural Glazing)
Façade tout en verre (Structural Glazing)
Structural Glazing façade
Facciata tutto vetro (structural glazing)

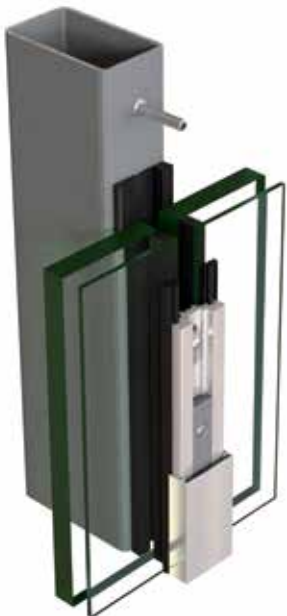

VISS Basic RC

Einbruchhemmende Fassade
Façade anti-effraction
Burglar protection façade
Facciata antieffrazione

Hinweise Remarques	Information Avvertenze	2
Konstruktionsvarianten Variantes de construction	Design options Varianti costruttivi	4
Universal T-Verbinder Raccord en T universel	Universal connecting spigot Raccordo a T universale	6
Schwerlast T-Verbinder einhängbar Raccord en T charge lourde à suspendre	Heavy-duty clip-in connecting spigot Raccordo a T per carichi elevati ad incastro	18
Elemente geschweisst Éléments soudés	Welded units Elementi saldati	32
Bauanschlüsse Raccords au mur	Attachment to structure Raccordi alla muratura	43
Systemtoleranzen Tolérances du système	System tolerances Tolleranze del sistema	50

Alle Ausführungen dieser Dokumentation haben wir sorgfältig und nach bestem Wissen zusammengestellt. Wir können aber keine Verantwortung für die Benützung der vermittelten Vorschläge und Daten übernehmen.

Nous avons apporté le plus grand soin à l'élaboration de cette documentation. Cependant, nous déclinons toute responsabilité pour l'utilisation faite de nos propositions et de nos données.

All the information contained in this documentation is given to the best of our knowledge and ability. However, we decline all responsibility for the use made of these suggestions and data.

Abbiamo dedicato la massima cura alla preparazione della presente documentazione. Decliniamo tuttavia ogni responsabilità per l'uso delle proposte e dei dati da noi forniti.

Allgemeine Hinweise

Beim vorliegenden System VISS-Basic handelt es sich um eine anwendungstechnische Erweiterung der VISS-Systeme. System-Zubehörteile ermöglichen den Dichtungsaufbau auch auf **systemunabhängige Tragkonstruktionen**.

Das Konstruktionsprinzip des Verglasungssystems beruht auf den bekannten VISS-Systemen.

Diese Verarbeitungs- und Montagerichtlinie behandelt lediglich den Aufbau der Tragkonstruktion insbesondere die Verbindungen von Pfosten zu Riegel für VISS Basic-Vertikalfassaden.

Detaillierte Informationen zur Verarbeitung und Montage der Dichtungssysteme, Zubehörteile, Füllelemente finden Sie in den jeweiligen Verarbeitungs- und Montagerichtlinien der einzelnen Systeme:

- VISS Basic
- VISS Basic SG
- VISS Basic RC

Die Tragkonstruktion ist grundsätzlich immer raumseitig anzuordnen.

General information

The VISS Basic system extends the range of applications of the VISS systems. The system accessories also allow sealing against **load-bearing structures from any system**.

The design of the glazing system is based on the renowned VISS systems.

These fabrication and installation guidelines only cover the construction of the load-bearing structure, in particular the mullion/transom joints for VISS Basic vertical façades.

Detailed information on the fabrication and installation of the sealing systems, accessories and infill units can be found in the respective fabrication and installation guidelines for the individual systems:

- VISS Basic
- VISS Basic SG
- VISS Basic RC

The load-bearing structure must always be positioned on the room side.

Remarques générales

Le système VISS-Basic que nous vous proposons est une extension des applications des systèmes VISS. Les accessoires du système permettent également l'étanchéification sur les **constructions porteuses indépendantes d'un système.**

Le principe de construction du système de vitrage repose sur les systèmes VISS connus.

Cette directive d'usinage et de montage traite uniquement du montage de la construction porteuse, en particulier des assemblages de montants et de traverses pour les façades verticales VISS Basic.

Des informations détaillées sur l'usinage et le montage des systèmes d'étanchéité, des accessoires et des éléments de remplissage sont données dans les directives d'usinage et de montage des différents systèmes:

- VISS Basic
- VISS Basic SG
- VISS Basic RC

La construction porteuse est toujours disposée côté intérieur.

Avvertenze generali

Il presente sistema VISS Basic costituisce un ampliamento tecnico ed applicativo dei sistemi VISS. Grazie agli accessori è possibile montare le guarnizioni anche su **strutture portanti indipendenti dal sistema.**

Il principio costruttivo di questo sistema di vetratura si basa sui noti sistemi VISS.

Le presenti istruzioni per la lavorazione e il montaggio si limitano a spiegare la disposizione della struttura portante, in particolare i collegamenti tra i montanti e i traversi per le facciate verticali VISS Basic.

Per informazioni dettagliate sulla lavorazione e il montaggio dei sistemi di guarnizioni, degli accessori e degli elementi di riempimento si consiglia di consultare il manuale di istruzioni per la lavorazione e il montaggio del sistema in uso:

- VISS Basic
- VISS Basic SG
- VISS Basic RC

Costruzione portante applicata sul lato interno.

Bauweise VISS Basic Tragkonstruktionen

Type de construction porteuse VISS Basic

Construction of VISS Basic load-bearing structures

Tipologie di costruzione delle strutture portanti VISS Basic

Rahmenbauweise
Riegel geschweisst

Méthode de construction
par éléments traverse soudée

Unitised construction
for welded transom

Costruzione a elementi
con traverso saldato

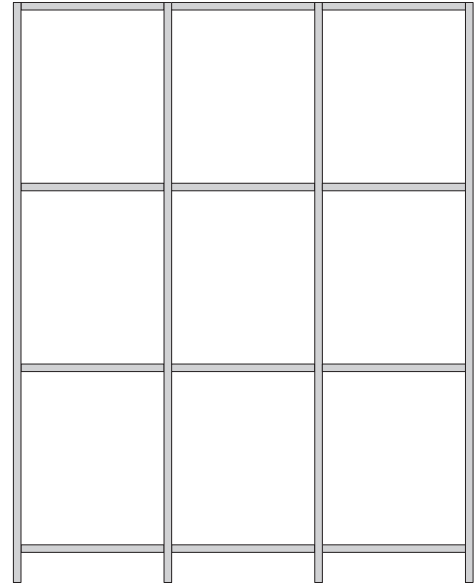
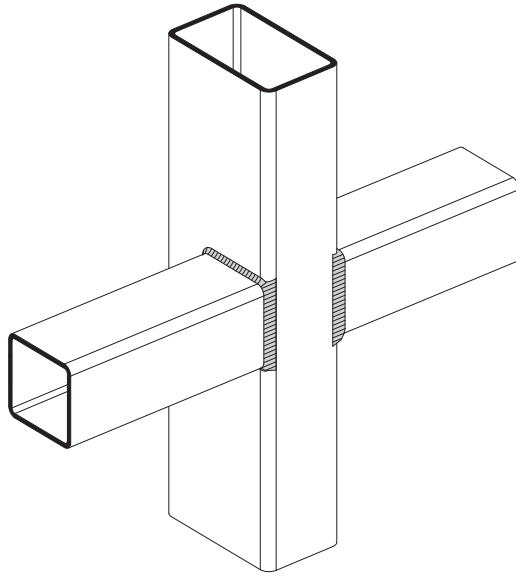

Steckbauweise mit
Universal T-Verbinder

Méthode de construction
modulaire avec
raccord en T universel

Push-on construction
with Universal
connecting spigot

Costruzione modulare
con raccordo
a T universale

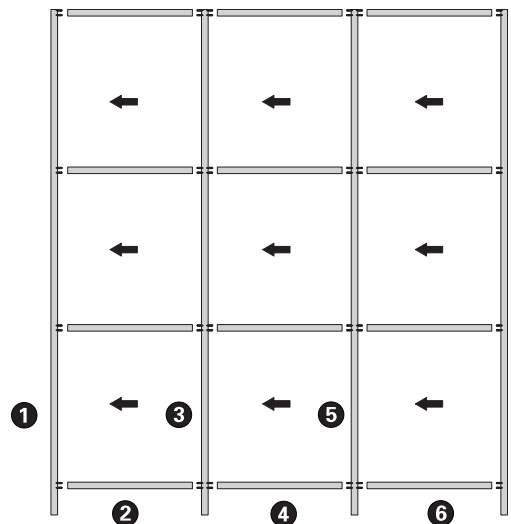
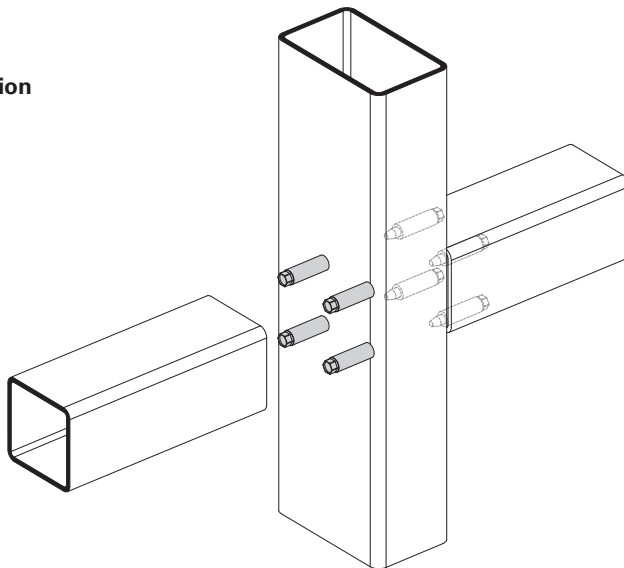

Steckbauweise mit
Schwerlast T-Verbinder
einhängbar

Méthode de construction
modulaire avec
raccord en T charge lourde
à suspendre

Push-on construction
with heavy-duty clip-in
connecting spigot

Costruzione modulare
con raccordo a T per
carichi elevati ad incastro

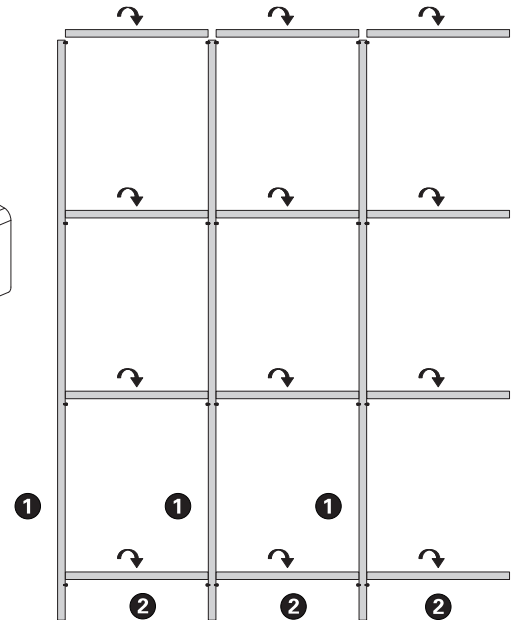
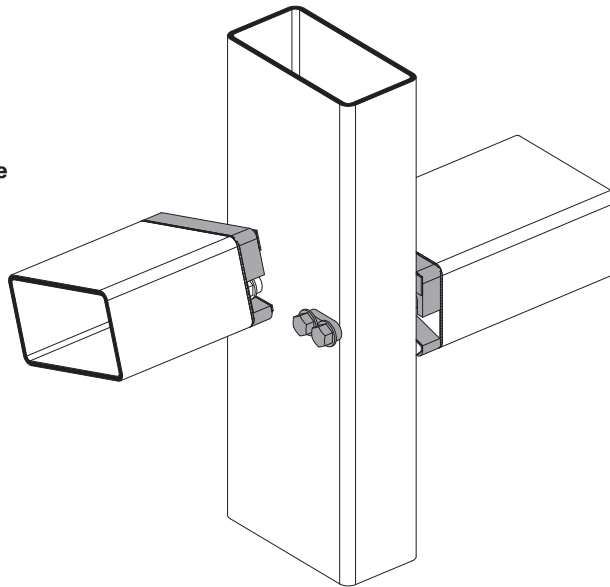

- ① = Montageablauf / Bauablauf
- = Déroulement du montage / déroulement de la construction
- = Installation sequence / construction sequence
- = sequenza delle operazioni di montaggio / costruzione

Universal T-Verbinder
Raccord en T universel
Universal connecting spigot
Raccordo a T universale

VISS Basic Tragkonstruktion
Construction porteuse VISS Basic
VISS Basic supporting structure
Struttura portante VISS Basic

Der Universal T-Verbinder ist bei folgenden VISS Basic Systemen einsetzbar:

The universal connecting spigot can be used in the following VISS Basic systems:

Le raccord en T universel est utilisable sur les systèmes VISS Basic suivants:

Il raccordo a T universale può essere utilizzato con i seguenti sistemi VISS Basic:

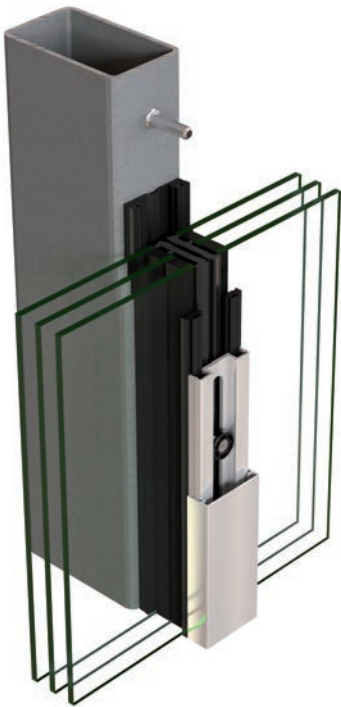

VISS Basic

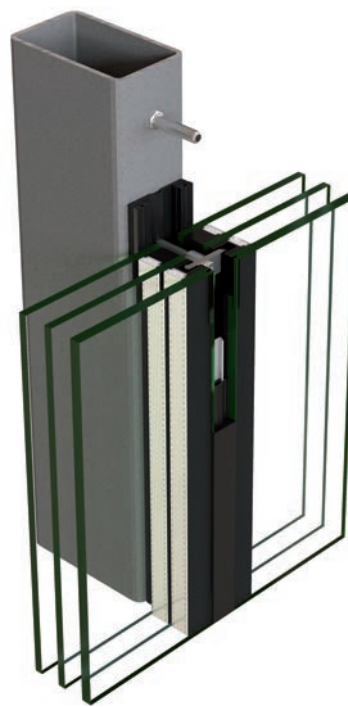

VISS Basic SG / VISS Basic Semi SG

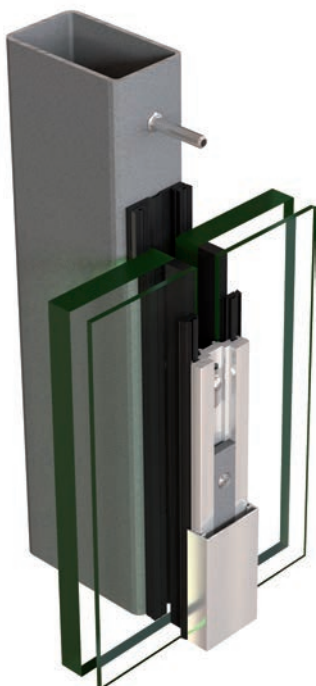

VISS Basic RC

Einsatzbereich:
Tragkonstruktion raumseitig angeordnet.
Nur für Innenbereiche trocken, ohne Feuchtigkeitsbelastung.

Area of application:
Load-bearing structure arranged on the room side.
For internal use in dry areas only, with no moisture.

Ablaufschritte:
Tragkonstruktion mit Universal T-Verbinder

	Seite
1. Konstruktionen	8
2. Verarbeitungshilfen	10
3. Füllelementgewichte / Tragfähigkeit	11
4. Verarbeitung	13
5. Oberflächenbehandlung	14
6. Bohrbild für CNC-Programmierung	16

Process steps:
Load-bearing structure with universal connecting spigot

	Page
1. Constructions	8
2. Assembly tools	10
3. Infill unit weights/load-bearing capacity	11
4. Processing	13
5. Surface treatment	14
6. Drilling pattern for CNC programming	16

Domaine d'utilisation:
Construction porteuse disposée côté intérieur.
Uniquement pour utilisation en intérieur à sec, sans humidité.

Campo di impiego:
Costruzione portante applicata sul lato interno.
Solo per ambienti asciutti, senza umidità.

Étapes du déroulement:
Construction porteuse avec raccord en T universel

	Page
1. Constructions	8
2. Outils d'usinage	10
3. Poids de remplissage / charge admissible	11
4. Usinage	13
5. Traitement de surface	14
6. Schéma de perçage pour programmation CNC	16

Sequenza delle operazioni:
Costruzione portante con raccordo a T universale

	Pagina
1. Tipologie di costruzione	8
2. Attrezzatura per il montaggio	10
3. Pesi degli elementi di riempimento / capacità portante	11
4. Lavorazione	13
5. Trattamento superficiale	14
6. Piano di foratura per la programmazione CNC	16

Konstruktionen

Constructions

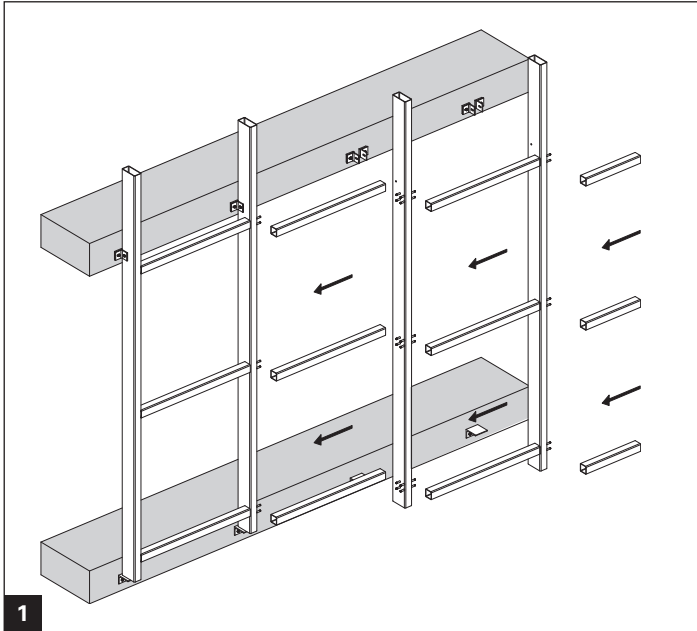

Steckbauweise
 Méthode de construction modulaire
 Push-ont construction
 Costruzione modulare

Constructions

Tipologie di costruzione

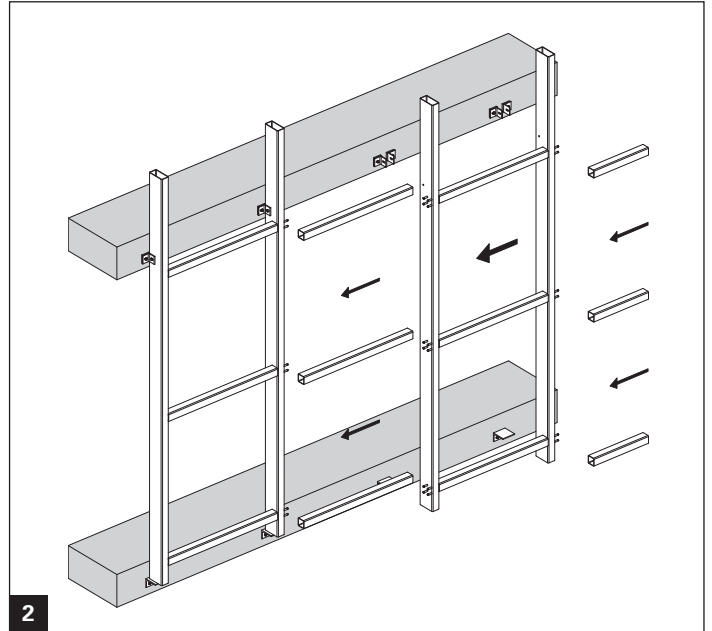

Rahmenbauweise / Steckbauweise
 Construction par éléments / construction modulaire
 Unitised construction / Push-on construction
 Costruzione a elementi / costruzione modulare

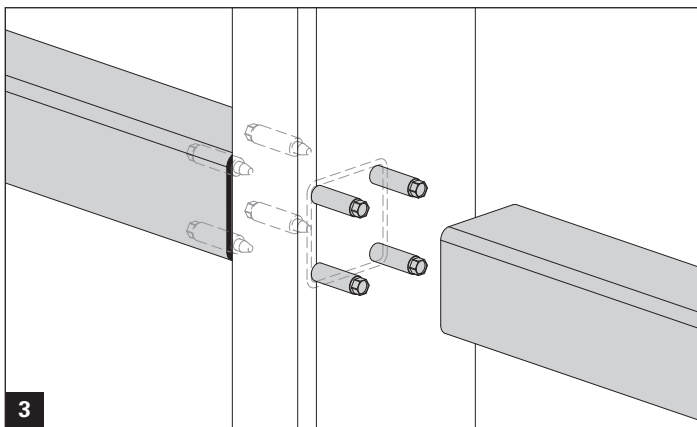

Riegel gesteckt
 Traverse emboîtée
 Slide-on transom
 Traverso a innesto

Standardausführung: Riegel gesteckt
Modèle standard: Traverse emboîtée
Standard model: Slide-on transom
Versione standard: traverso a innesto

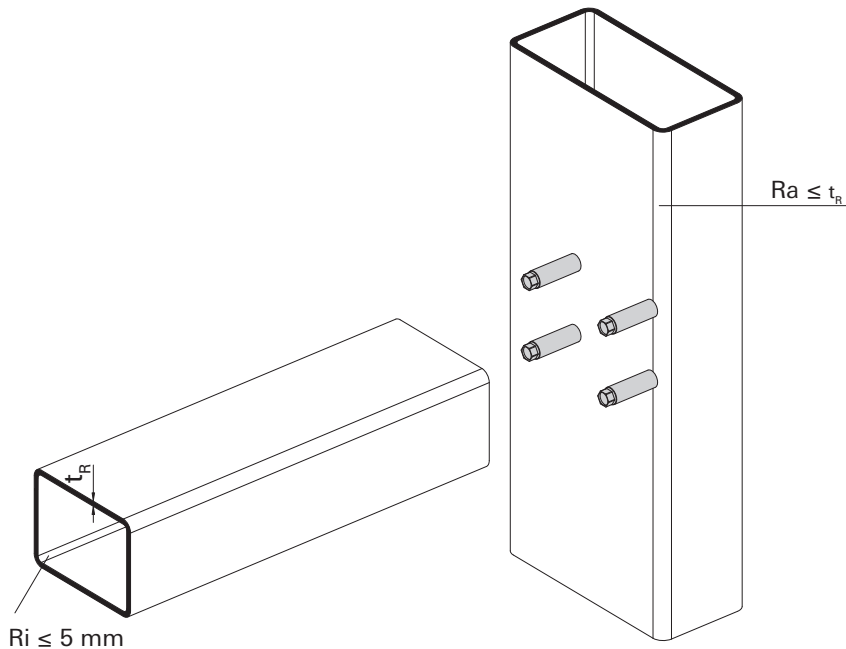

VISS Basic

Hohlprofil
 (Pfosten $Ri \leq 2$ mm / Riegel $Ri \leq 5$ mm)

Profilé creux
 (Montant $Ri \leq 2$ mm/Traverse $Ri \leq 5$ mm)

Hollow profile
 (Mullion $Ri \leq 2$ mm/Transom $Ri \leq 5$ mm)

Profilo cavo
 (Montante $Ri \leq 2$ mm/Traverso $Ri \leq 5$ mm)

VISS I_xtra

Kastenprofil scharfkantig

Profilé de boîte angle vif

Box profile sharp-edged

Profilo scatolato ad angoli vivi

VISS Basic

Edelstahl
 (Pfosten $Ri \leq 2$ mm/Riegel $Ri \leq 5$ mm)

Acier Inox
 (Montant $Ri \leq 2$ mm/Traverse $Ri \leq 5$ mm)

Stainless steel
 (Mullion $Ri \leq 2$ mm/Transom $Ri \leq 5$ mm)

Acciaio inox
 (Montante $Ri \leq 2$ mm/Traverso $Ri \leq 5$ mm)

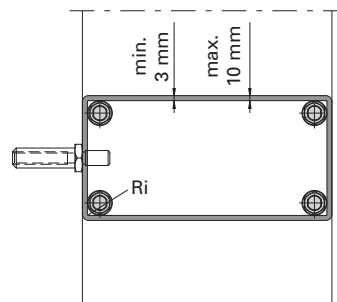
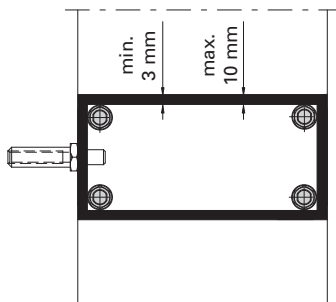
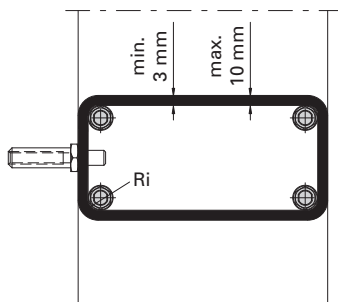

Universal T-Verbinder
Raccord en T universel
Universal connecting spigot
Raccordo a T universale

VISS Basic Tragkonstruktion
Construction porteuse VISS Basic
VISS Basic supporting structure
Struttura portante VISS Basic

Verarbeitungshilfen

Outils d'usinage



499.234

Tiefenanschlag

Stahl verzinkt, für Bohrer
Ø 5,3 mm, optional
beim Bohren mittels
Handbohrmaschine

VE = 1 Stück

499.234

Butée

acier galvanisé, pour
foret Ø 5,3 mm, en
option pour perçage
avec perceuse manuelle

UV = 1 pièce

499.234

Depth stop

galvanised steel, for
drill bit Ø 5.3 mm,
optional when using
a hand-held drill

PU = 1 piece

499.234

Battuta di profondità

acciaio zincato, per
punte da Ø 5,3 mm,
opzionale per foratura
con trapano a mano

UV = 1 pezzo

Assembly tools

Attrezzatura per il montaggio



499.395

Schraubenadapter

Stahl verzinkt, zur
rationellen Montage
der Bolzen

VE = 1 Stück

499.395

Adaptateur à vis

acier galvanisé, pour le
montage rationnel des
goujons

UV = 1 pièce

499.395

Screw adapter

galvanised steel, for
screwing-in the bolt
sleeve

PU = 1 piece

499.395

Adattatore per viti

acciaio zincato, per il
montaggio razionale
dei bulloni

UV = 1 pezzo

Füllelementgewichte / Tragfähigkeit (G)

Poids de remplissage / Charge admissible (G)

Weight of infill elements / Load capacity (G)

Peso elemento di riempimento / Capacità portante (G)

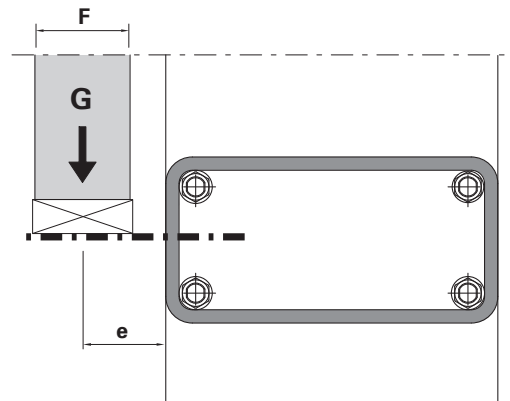
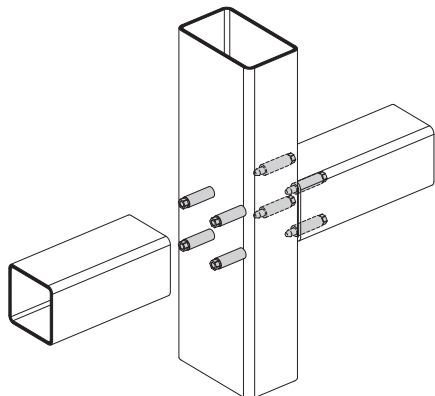

2x1 Traganker
 2x1 Boulons-supports
 2x1 Supporting bolts
 2x1 Bullone di supporto

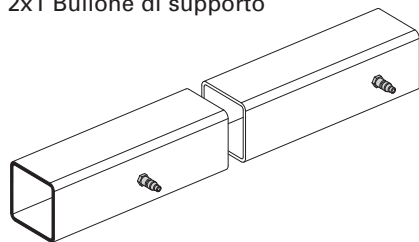

		50 mm		60 mm	
F	e	Dimension	G	Dimension	G
mm	mm	Dimension		Dimension	
		Dimension		Dimension	
		Dimensione		Dimensione	
6 - 40	30	min. 50/50/3 mm	0,75 kN	min. 60/50/3 mm	0,75 kN

2x2 Traganker
 2x2 Boulons-supports
 2x2 Supporting bolts
 2x2 Bullone di supporto

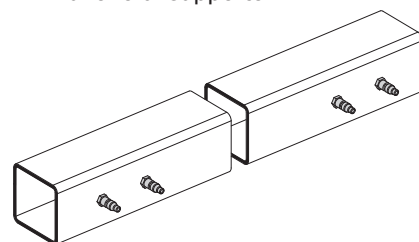

		50 mm		60 mm	
F	e	Dimension	G	Dimension	G
mm	mm	Dimension		Dimension	
		Dimension		Dimension	
		Dimensione		Dimensione	
6 - 40	30	min. 50/50/3 mm	1,5 kN	min. 60/50/3 mm	1,5 kN

2x3 Traganker
 2x3 Boulons-supports
 2x3 Supporting bolts
 2x3 Bullone di supporto

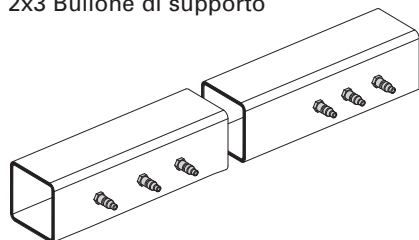

		50 mm		60 mm	
F	e	Dimension	G	Profil	G
mm	mm	Dimension		Profilé	
		Dimension		Profile	
		Dimensione		Profilo	
6 - 40	30	min. 50/50/3 mm	2,5 kN	min. 60/50/3 mm	2,5 kN
		min. 50/80/3 mm	3 kN	min. 60/80/3 mm	3 kN

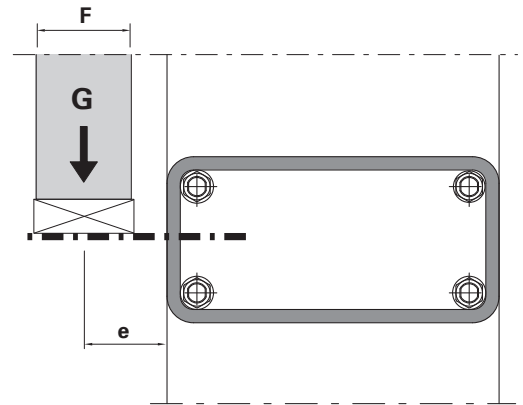
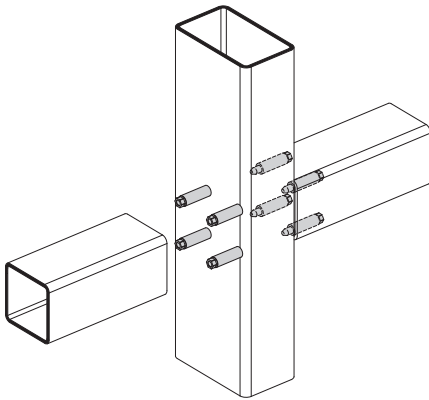

Flachstahl eingeschweisst
 Acier plat soudé
 Flat steel welding
 Piastra in acciaio saldata

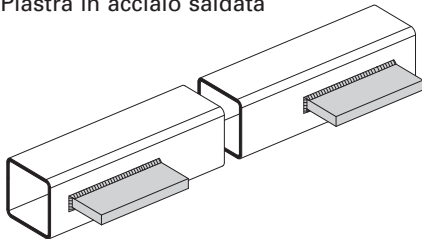

		50 mm		60 mm	
F	e	Min. Dimension Dimension min. Min. dimension Min. dimensione	G	Min. Dimension Dimension min. Min. dimension Min. dimensione	G
mm	mm				
6 - 24	22	50/50/3	3 kN	60/50/3	3 kN
		50/60/3	3 kN	60/80/3	4 kN
		50/80/3	4 kN	60/100/3	6 kN
		50/95/3	5 kN	60/120/3	7 kN
		50/120/3	7 kN	60/150/3	8 kN
		50/140/3	7 kN		
25 - 39	29,5	50/50/3	2,75 kN	60/50/3	2,75 kN
		50/60/3	2,75 kN	60/80/3	3,5 kN
		50/80/3	3,5 kN	60/100/3	5 kN
		50/95/3	4,5 kN	60/120/3	6 kN
		50/120/3	6 kN	60/150/3	7 kN
		50/140/3	6 kN		
40 - 54	37	50/50/3	2,5 kN	60/50/3	2,5 kN
		50/60/3	2,5 kN	60/80/3	3 kN
		50/80/3	3 kN	60/100/3	4 kN
		50/95/3	4 kN	60/120/3	4,5 kN
		50/120/3	4,5 kN	60/150/3	5 kN
		50/140/3	4,5 kN		

Hinweis:

Die maximale Riegeldurchbiegung L/500 darf nicht überschritten werden und jegliche Berührung zwischen Riegel und Füllelement (Ausfachung) muss verhindert werden.

Werden die obigen Füllelementgewichte überschritten, so ist eine Prüfung im Einzelfall erforderlich.

Remarque:

Le flambage maximal de la traverse L/500 ne doit pas être dépassé et tout contact entre traverse et élément de remplissage (boulons-support et supports de vitrage) doit être empêché.

Si les poids de remplissage indiqués ci-dessus sont dépassés, un contrôle du cas particulier sera nécessaire.

Note:

The maximum transom deflection L/500 must not be exceeded and any contact between transom and infill unit (infill) must be prevented.

If the above infill unit weights are exceeded, an individual test is required.

Nota:

Non deve essere superata il valore massimo di flessione del traverso L/500 ed è necessario evitare qualsiasi contatto fra il traverso e l'elemento di riempimento (tamponamento).

Qualora i pesi degli elementi di riempimento riportati sopra vengano superati, sarà necessaria una verifica caso per caso.

Verarbeitung

Usinage

1. Zuschnitt Riegel
1. Découpe traverse

Processing

Lavorazione

1. Transom cutting
1. Taglio dei traversi

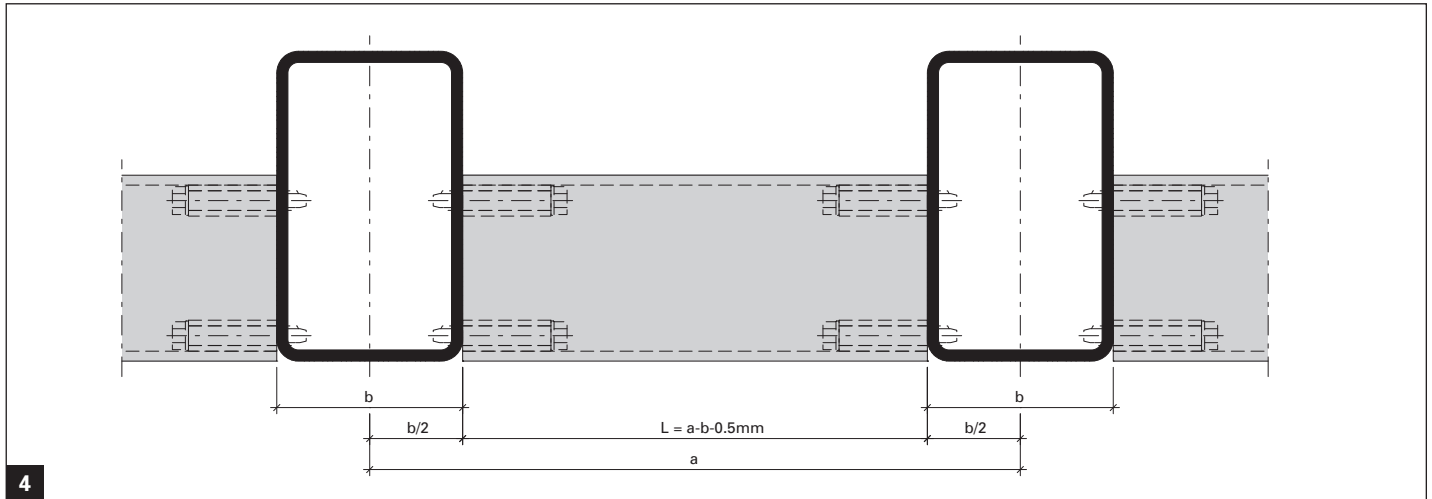

Länge Riegel $L = a - b$

a = Achsmass
 b = Profilbreite
 L = Riegellänge

Longueur traverse $L = a - b$

a = Entraxe
 b = Largeur du profilé
 L = Longueur de la traverse

Length of transom $L = a - b$

a = Axis dimension
 b = Profile width
 L = Transom length

Lunghezza traverso $L = a - b$

a = Interasse
 b = Larghezza profilo
 L = Lunghezza traverso

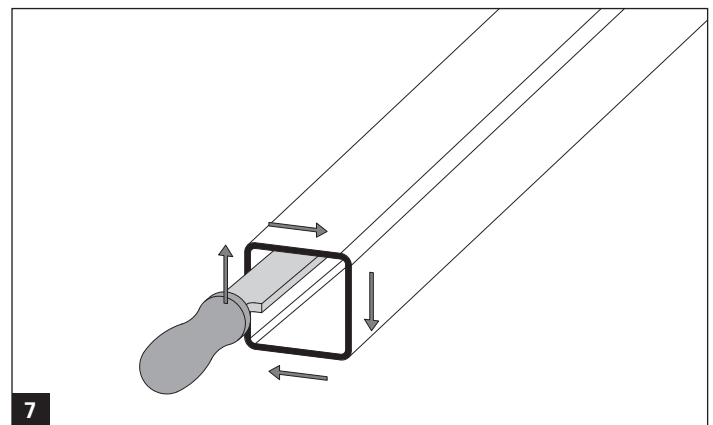
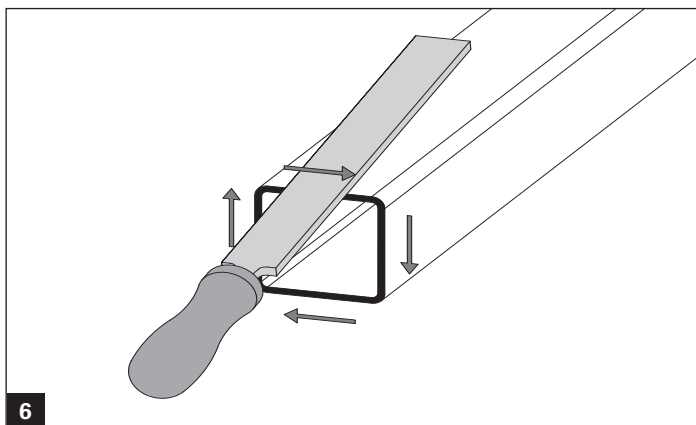
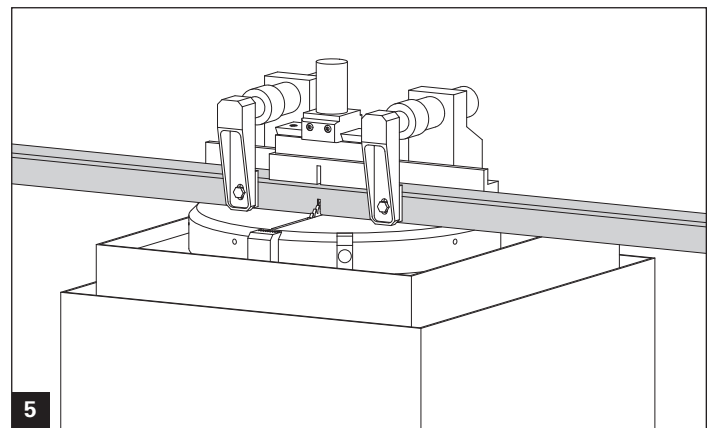

Oberflächenbehandlung Tragkonstruktion

Nachdem die Pfosten und Riegel der Tragkonstruktion in der Werkstatt fertig erstellt sind, ist die Oberflächenbehandlung vorzunehmen.

Traitement de la surface de la construction porteuse

Il doit être procédé au traitement de surface quand les montants et traverses de la construction porteuse ont été réalisés à l'atelier.

- 2. Montage
- 2. Montage

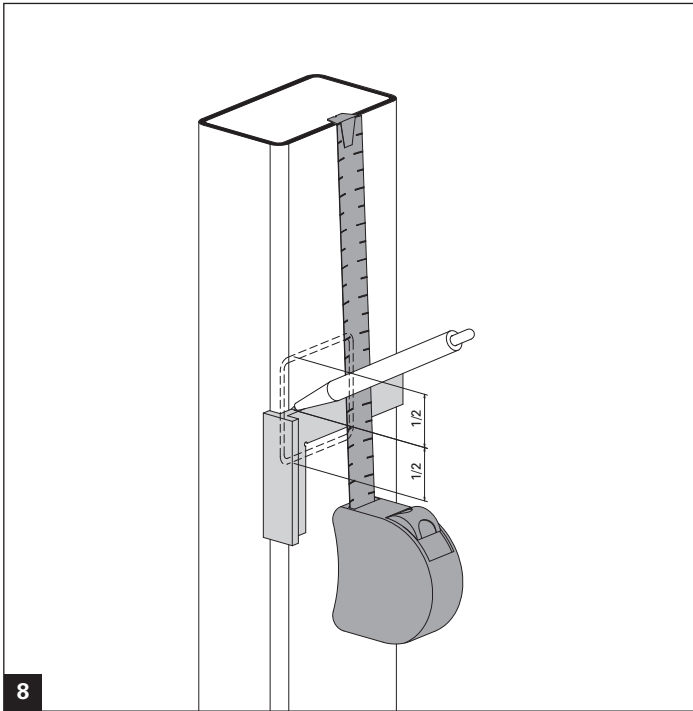

Surface treatment of the load-bearing structure

After the mullion and transom of the load-bearing structure have been completed in the workshop, the surface treatment is to be applied.

Trattamento superficiale della struttura portante

Una volta che i montanti e i traversi della struttura portante sono stati realizzati in officina, è necessario provvedere al loro trattamento superficiale.

- 2. Assembly
- 2. Montaggio

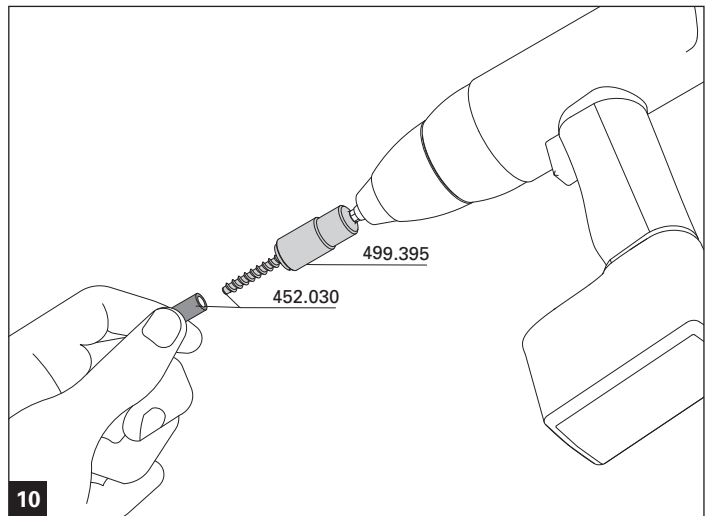
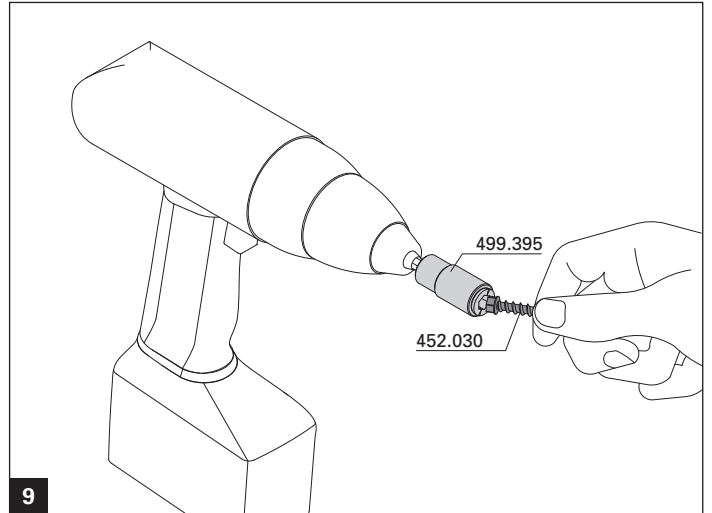

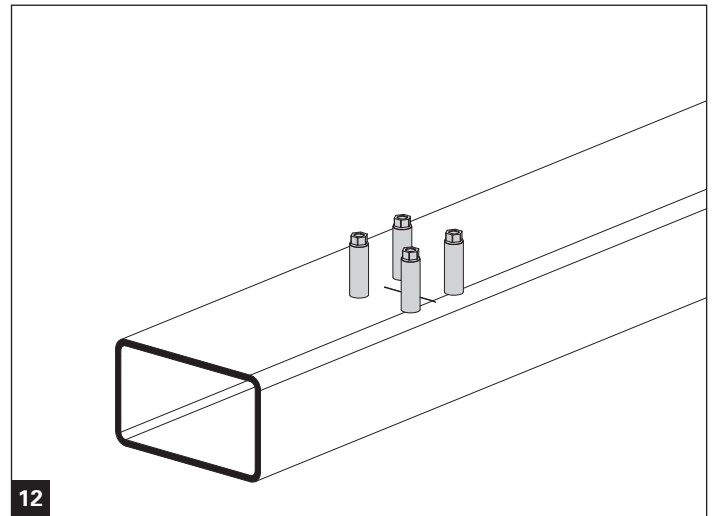
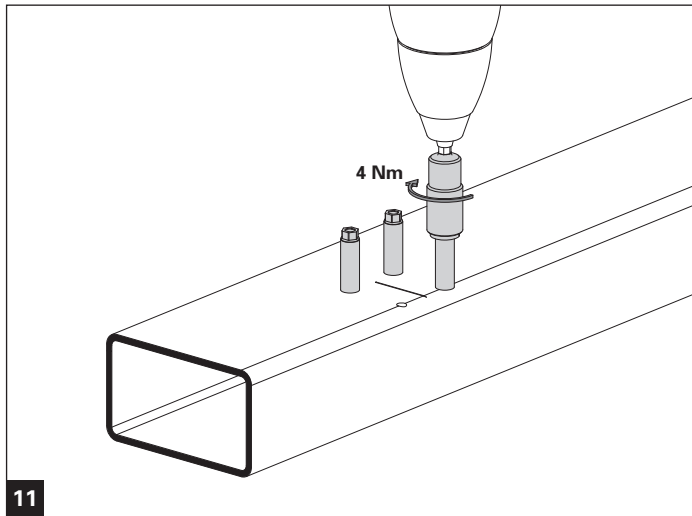

3. *Montage Pfosten/Riegel*
 3. *Montage montant/traverse*

3. *Mullion/transom assembly*
 3. *Montaggio montante/traverso*

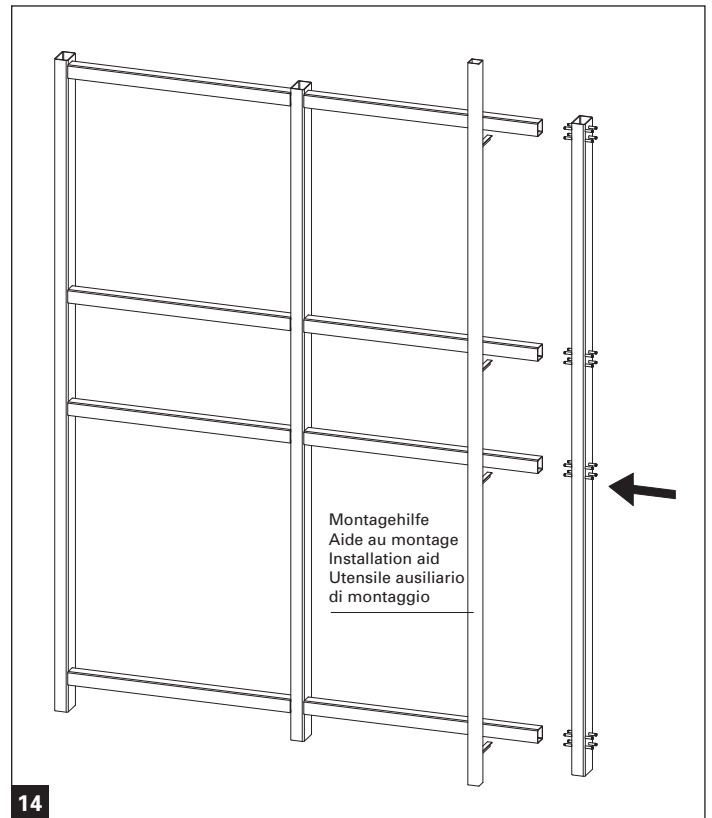
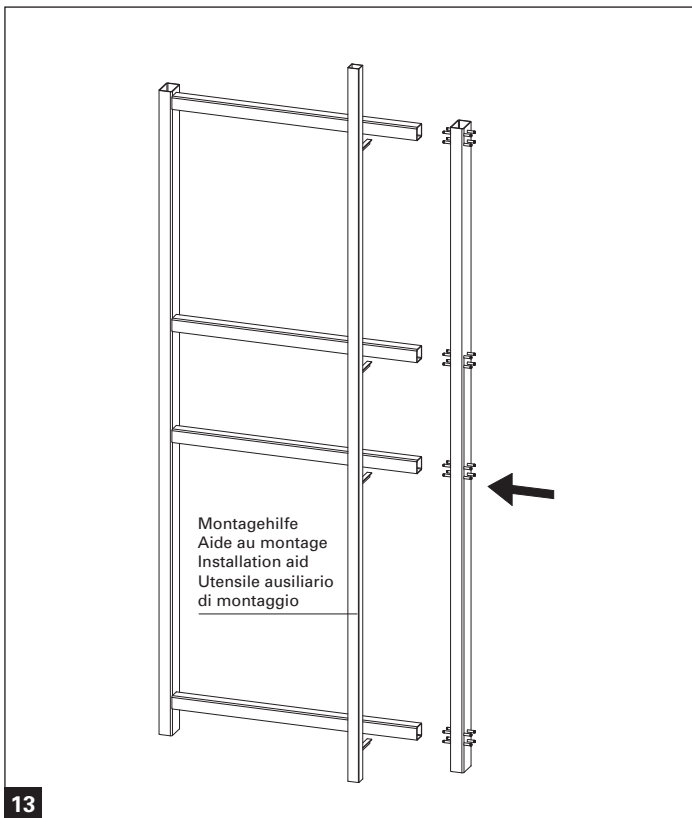

Bohrbild für CNC-Programmierung

Schéma de perçage pour programmation CNC

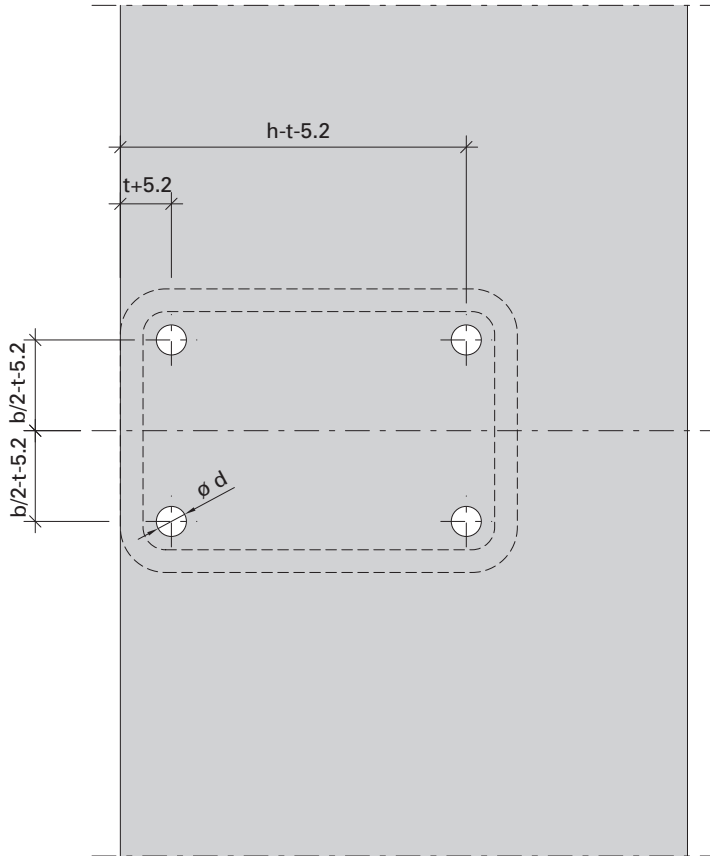

Drilling pattern for CNC programming

Piano di foratura per la programmazione CNC

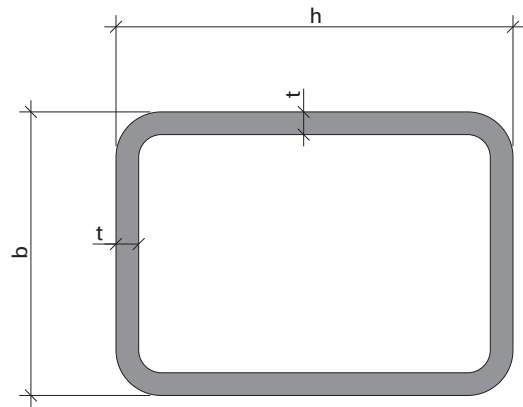

h = Profiltiefe
b = Ansichtsbreite / Profilhöhe
t = Wandstärke
d = Bohrdurchmesser

h = Profondeur du profilé
b = Largeur de face / hauteur du profilé
t = Epaisseur de paroi
d = Diamètre de perçage

h = Profile depth
b = Face width / profile height
t = Wall thickness
d = Drilling diameter

h = Profondità del profilo
b = Larghezza in vista / altezza del profilo
t = Spessore della parete
d = Diametro dei fori

Bohrdurchmesser (d) in Abhängigkeit der Wandstärke

Schéma de perçage pour programmation CNC

Drilling pattern for CNC programming

Piano di foratura per la programmazione CNC

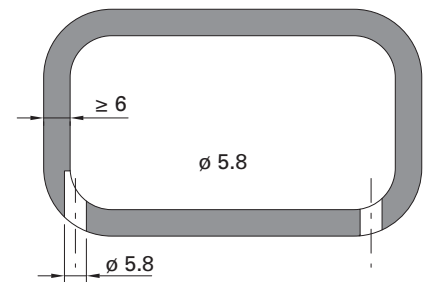
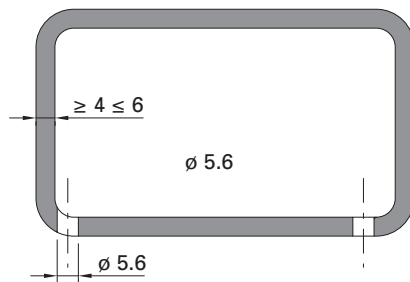
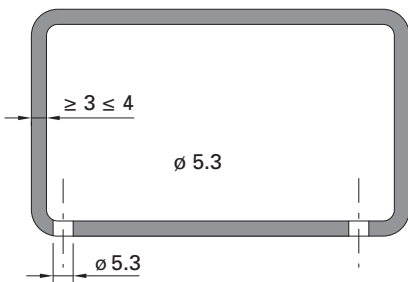
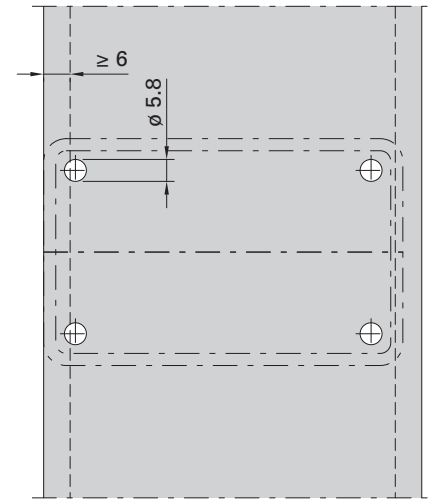
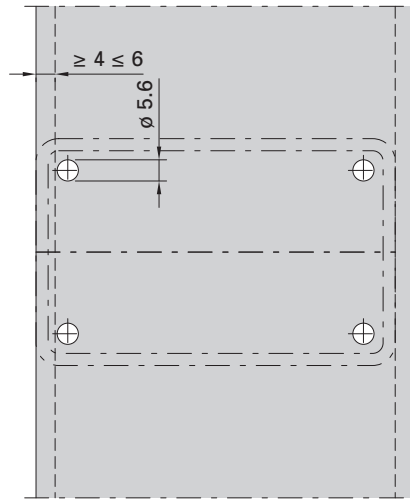
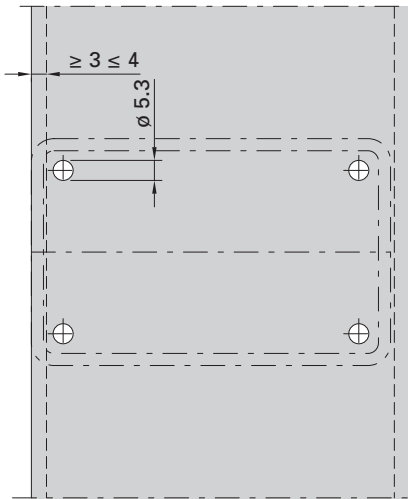

Schwerlast T-Verbinder einhängbar
Raccord en T charge lourde à suspendre
Heavy-duty clip-in connecting spigot
Raccordo a T per carichi elevati ad incastro

VISS Basic Tragkonstruktion
Construction porteuse VISS Basic
VISS Basic supporting structure
Struttura portante VISS Basic

Der Schwerlast T-Verbinder einhängbar ist bei folgenden VISS Basic Systemen einsetzbar:

The heavy-duty clip-in connecting spigot can be used in the following VISS Basic systems:

Le raccord en T charge lourde à suspendre est utilisable sur les systèmes VISS Basic suivants:

Il raccordo a T per carichi elevati ad incastro può essere utilizzato con i seguenti sistemi VISS Basic:

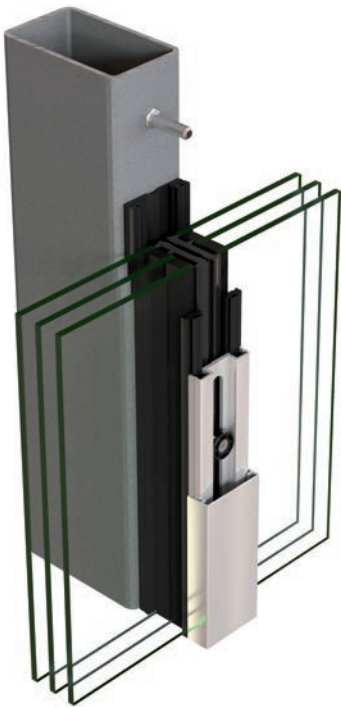

VISS Basic

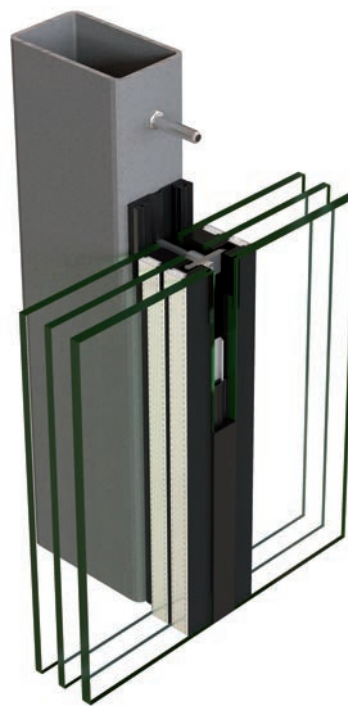

VISS Basic SG / VISS Basic Semi SG

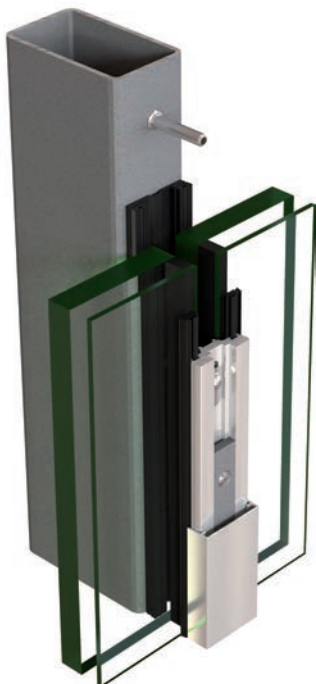

VISS Basic RC

Schwerlast T-Verbinder einhängbar
Raccord en T charge lourde à suspendre
Heavy-duty clip-in connecting spigot
Raccordo a T per carichi elevati ad incastro

VISS Basic Tragkonstruktion
Construction porteuse VISS Basic
VISS Basic supporting structure
Struttura portante VISS Basic

Einsatzbereich:
Tragkonstruktion raumseitig angeordnet.
Nur für Innenbereiche trocken, ohne Feuchtigkeitsbelastung.

Area of application:
Load-bearing structure arranged on the room side.
For internal use in dry areas only, with no moisture.

Ablaufschritte:
Tragkonstruktion mit Schwerlast T-Verbinder einhängbar

Process steps: Load-bearing structure with heavy-duty clip-in connecting spigot

	Seite
1. Konstruktionen	20
2. Verarbeitungshilfen	21
3. Füllelementgewichte / Tragfähigkeit	22
4. Verarbeitung	24
5. Oberflächenbehandlung	26
6. Bohrbild für CNC-Programmierung	29

	Page
1. Constructions	20
2. Assembly tools	21
3. Infill unit weights/load-bearing capacity	22
4. Processing	24
5. Surface treatment	26
6. Drilling pattern for CNC programming	29

Domaine d'utilisation:
Construction porteuse disposée côté intérieur.
Uniquement pour utilisation en intérieur à sec, sans humidité.

Campo di impiego:
Costruzione portante applicata sul lato interno.
Solo per ambienti asciutti, senza umidità.

Étapes du déroulement: Construction porteuse avec raccord en T charge lourde à suspendre

Sequenza delle operazioni: Struttura portante con raccordo a T per carichi elevati ad incastro

	Page
1. Constructions	20
2. Outils d'usinage	21
3. Poids de remplissage / charge admissible	22
4. Usinage	24
5. Traitement de surface	26
6. Schéma de perçage pour programmation CNC	29

	Pagina
1. Tipologie di costruzione	20
2. Attrezzatura per il montaggio	21
3. Pesi degli elementi di riempimento / capacità portante	22
4. Lavorazione	24
5. Trattamento superficiale	26
6. Piano di foratura per la programmazione CNC	29

Schwerlast T-Verbinder einhängbar
 Raccord en T charge lourde à suspendre
 Heavy-duty clip-in connecting spigot
 Raccordo a T per carichi elevati ad incastro

VISS Basic Tragkonstruktion
 Construction porteuse VISS Basic
 VISS Basic supporting structure
 Struttura portante VISS Basic

Konstruktionen

Constructions

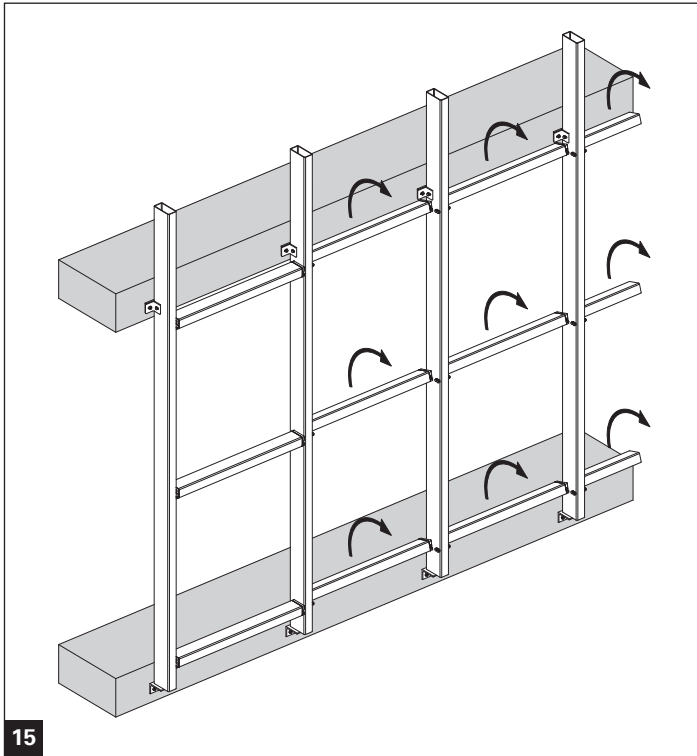

Steckbauweise
 Méthode de construction modulaire
 Push-on construction
 Costruzione modulare

Constructions

Tipologie di costruzione

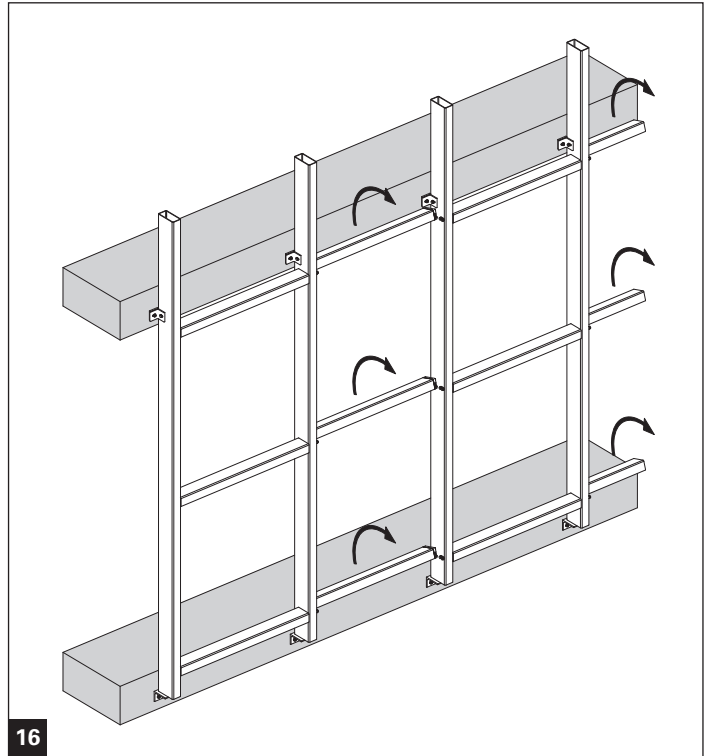

Rahmenbauweise / Steckbauweise
 Construction par éléments / construction modulaire
 Unitised construction / Push-on construction
 Costruzione a elementi / costruzione modulare

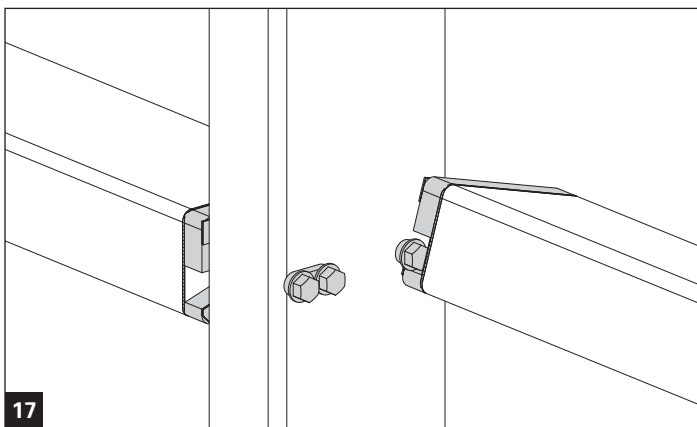

Einbausituation Schwerlast T-Verbinder
 Situation de montage du raccord en T charge lourde
 Installation location of heavy-duty connecting spigot
 Montaggio del raccordo a T per carichi elevati

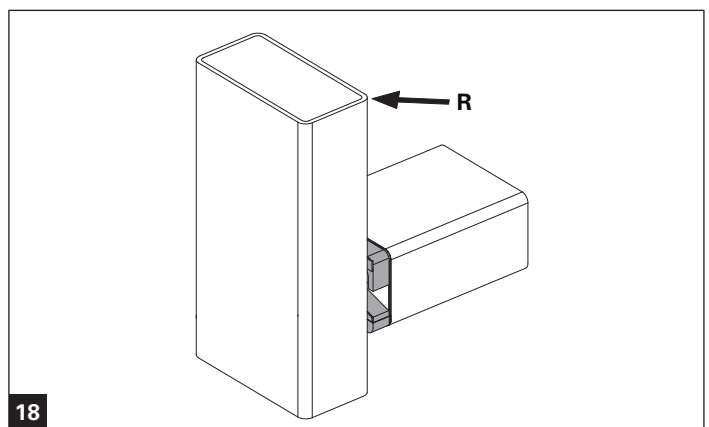

Der Kantenradius (R) im Pfostenprofil darf max. 6 mm betragen.
 Le rayon d'angle (R) dans le profilé de montant ne doit pas être supérieur à 6 mm.
 The edge radius (R) in the mullion profile must be no larger than 6 mm.
 Il raggio del bordo (R) del profilo per i montanti può essere di max. 6 mm.

Schwerlast T-Verbinder einhängbar
Raccord en T charge lourde à suspendre
Heavy-duty clip-in connecting spigot
Raccordo a T per carichi elevati ad incastro

VISS Basic Tragkonstruktion
 Construction porteuse VISS Basic
 VISS Basic supporting structure
 Struttura portante VISS Basic

Verarbeitungshilfen

Outils d'usinage

Assembly tools

Attrezzatura per il montaggio



499.404 50 mm
499.405 60 mm

Bohrplatte
 Aluminium,
 Bohrhülsen ø 7,2 mm

VE = 1 Stück

499.404 50 mm
499.405 60 mm

Plaque de perçage
 aluminium, douilles de
 perçage ø 7,2 mm

UV = 1 pièce

499.404 50 mm
499.405 60 mm

Drilling template
 aluminium,
 drill sleeve ø 7,2 mm

PU = 1 piece

499.404 50 mm
499.405 60 mm

Dima di foratura
 alluminio, bussola di
 foratura ø 7,2 mm

PU = 1 piece



499.010
Bohrplatte
 Aluminium,
 Bohrhülsen ø 7,2 mm

VE = 1 Stück

499.010
Plaque de perçage
 aluminium, douilles de
 perçage ø 7,2 mm

UV = 1 pièce

499.010
Drilling template
 aluminium,
 drill sleeve ø 7,2 mm

PU = 1 piece

499.010
Dima di foratura
 alluminio, bussola di
 foratura ø 7,2 mm

PU = 1 piece

Die Klemmplatte 499.207/499.208 kann in Teilen als Anschlaghilfe verwendet werden.

La plaque de serrage 499.207/499.208 peut servir d'aide au positionnement dans les pièces.

The clamping plate 499.207/499.208 can be used as a stopping aid in places.

La piastra di fissaggio 499.207/499.208 è utilizzabile come guida nei componenti.

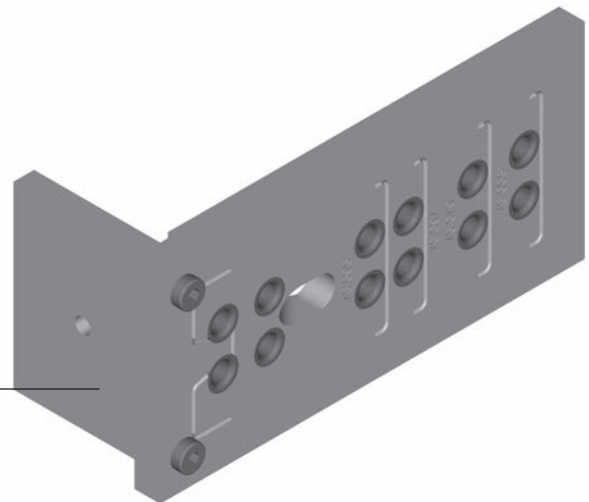

Schwerlast T-Verbinder einhängbar
 Raccord en T charge lourde à suspendre
 Heavy-duty clip-in connecting spigot
 Raccordo a T per carichi elevati ad incastro

VISS Basic Tragkonstruktion
 Construction porteuse VISS Basic
 VISS Basic supporting structure
 Struttura portante VISS Basic

Füllelementgewichte / Tragfähigkeit (G)

Infill unit weights / Load-bearing capacity (G)

Poids de remplissage / Charge admissible (G)

Pesi degli elementi di riempimento / Capacità portante (G)

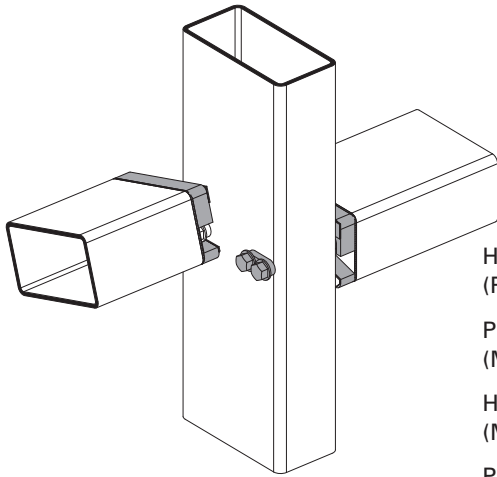

Hohlprofil
 (Pfosten $R_i \leq 2$ mm / Riegel $R_i \leq 5$ mm)

Profilé creux
 (Montant $R_i \leq 2$ mm/Traverse $R_i \leq 5$ mm)

Hollow profile
 (Mullion $R_i \leq 2$ mm/Transom $R_i \leq 5$ mm)

Profilo cavo
 (Montante $R_i \leq 2$ mm/Traverso $R_i \leq 5$ mm)

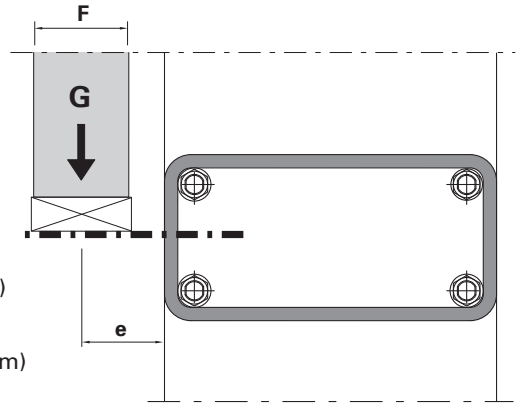

Flachstahl eingeschweisst
 Acier plat soudé
 Flat steel welding
 Piastra in acciaio saldata

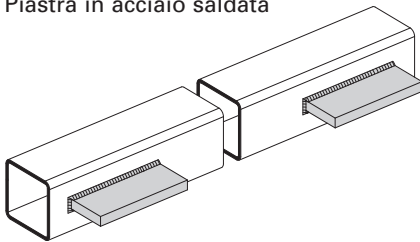

		50 mm		
F	e	Min. Dimension Dimension min. Min. Dimension Min. Dimensione	Schwerlast-T-Verbinder Raccord en T charge lourde Heavy duty connecting spigot Raccordo a T per carichi elevati	G
mm	mm			
6 - 20	20	50/80/3	452.060	8 kN
		50/95/3	462.061	12 kN
		50/120/3	452.062	13 kN
		50/140/3	452.063	13 kN
21 - 40	30	50/80/3	452.060	7 kN
		50/95/3	452.061	10 kN
		50/120/3	452.062	11 kN
		50/140/3	452.063	11 kN
41 - 70	45	50/80/3	452.060	6 kN
		50/95/3	452.061	8 kN
		50/120/3	452.062	9 kN
		50/140/3	452.063	9 kN

Hinweis:

Die maximale Riegeldurchbiegung L/500 darf nicht überschritten werden und jegliche Berührung zwischen Riegel und Füllelement (Ausfachung) muss verhindert werden.

Werden die obigen Füllelementgewichte überschritten, so ist eine Prüfung im Einzelfall erforderlich.

Auf Anfrage können objektspezifische alternative Abmessungen gefertigt werden.

Note:

The maximum transom deflection L/500 must not be exceeded and any contact between transom and infill unit (infill) must be prevented.

If the above infill unit weights are exceeded, an individual test is required.

Project-specific, alternative dimensions can be fabricated on request.

Flachstahl eingeschweisst
 Acier plat soudé
 Flat steel welding
 Piastra in acciaio saldata

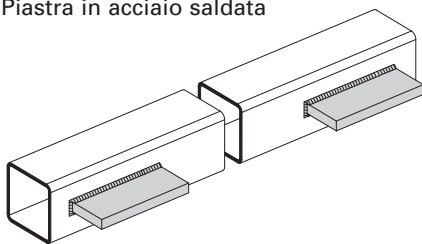

		60 mm		
F	e	Min. Dimension Dimension min. Min. Dimension Min. Dimensione	Schwerlast-T-Verbinder Raccord en T charge lourde Heavy duty connecting spigot Raccordo a T per carichi elevati	G
mm	mm			
6 - 20	20	60/80/3	452.070	12 kN
		60/100/3	462.071	14 kN
		60/120/3	452.072	15 kN
		60/150/3	452.073	18 kN
21 - 40	30	60/80/3	452.070	10 kN
		60/100/3	452.071	12 kN
		60/120/3	452.072	13 kN
		60/150/3	452.073	14 kN
41 - 70	45	60/80/3	452.070	8 kN
		60/100/3	452.071	10 kN
		60/120/3	452.072	11 kN
		60/150/3	452.073	12 kN

Remarque:

Le flambage maximal de la traverse L/500 ne doit pas être dépassé et tout contact entre traverse et élément de remplissage (boulons-support et supports de vitrage) doit être empêché.

Si les poids de remplissage indiqués ci-dessus sont dépassés, un contrôle du cas particulier sera nécessaire.

D'autres dimensions spécifiques à un objet sont possibles sur demande.

Nota:

Non deve essere superata il valore massimo di flessione del traverso L/500 ed è necessario evitare qualsiasi contatto fra il traverso e l'elemento di riempimento (tamponamento).

Qualora i pesi degli elementi di riempimento riportati sopra vengano superati, sarà necessaria una verifica caso per caso.

Su richiesta è possibile fornire misure alternative specifiche per l'edificio in questione.

Verarbeitung

Usinage

1. Zuschnitt Riegel
1. Découpe traverse

Processing

Lavorazione

1. Transom cutting
1. Taglio dei traversi

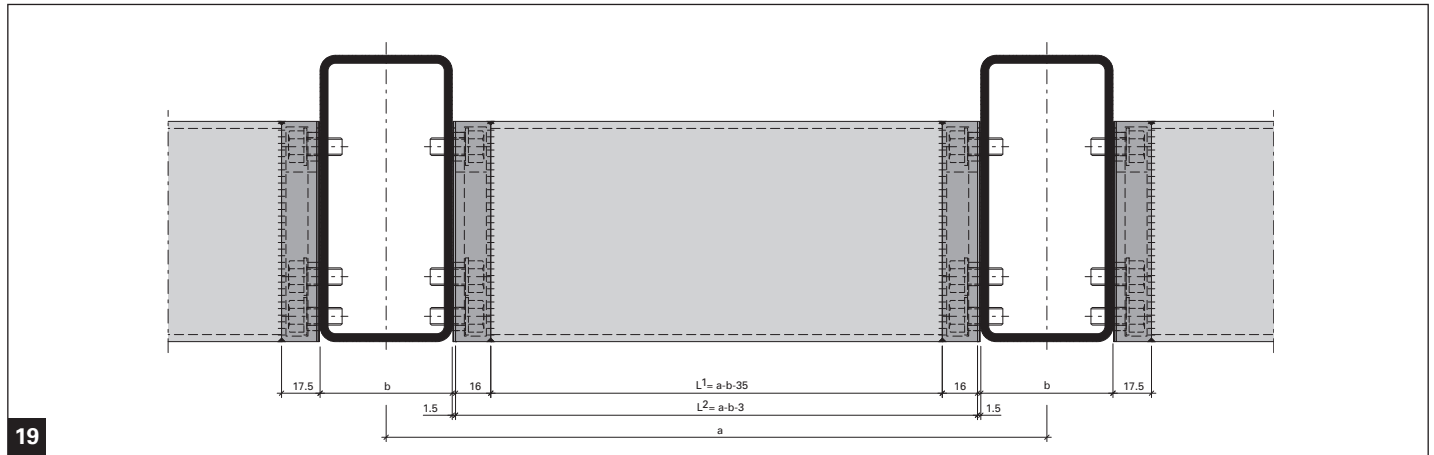

19

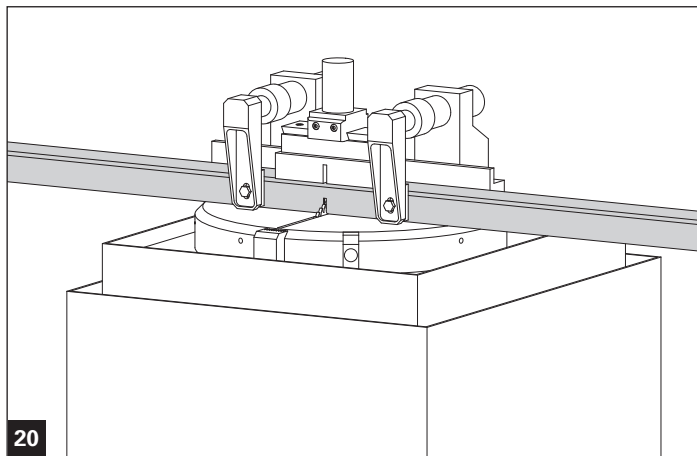

20

Riegellänge ohne T-Verbinder $L1 = a - b - 35$
 Riegellänge mit T-Verbinder $L2 = a - b - 3$

a = Achsmass
 b = Profilbreite

Longueur traverse sans raccord en T $L1 = a - b - 35$
 Longueur traverse avec raccord en T $L2 = a - b - 3$

a = Entraxe
 b = Largeur du profilé

Transom length without connecting spigot $L1 = a - b - 35$
 Transom length with connecting spigot $L2 = a - b - 3$

a = Axis dimension
 b = Profile width

Lunghezza traverso senza raccordo a T $L1 = a - b - 35$
 Lunghezza traverso con raccordo a T $L2 = a - b - 3$

a = Interasse
 b = larghezza profilo

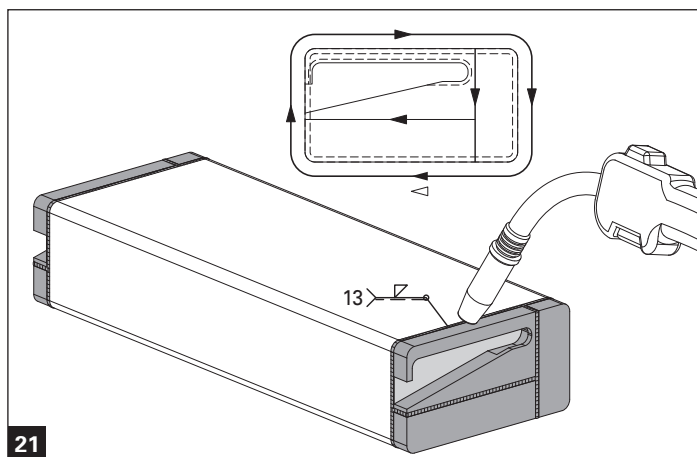

21

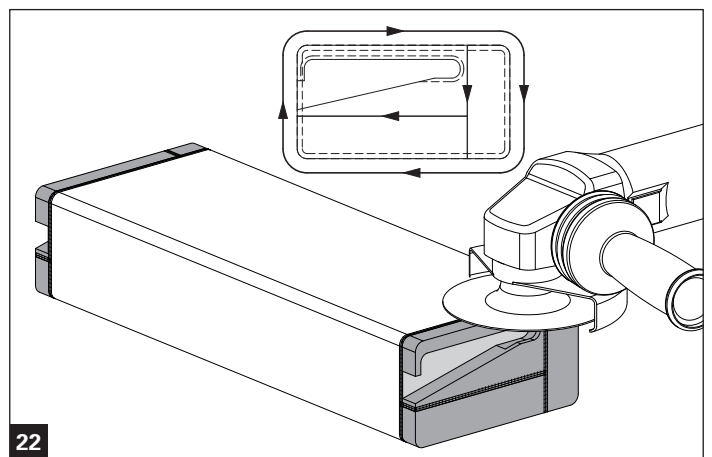

22

2. Bohrungen
 2. Perçages

2. Drill holes
 2. Fori

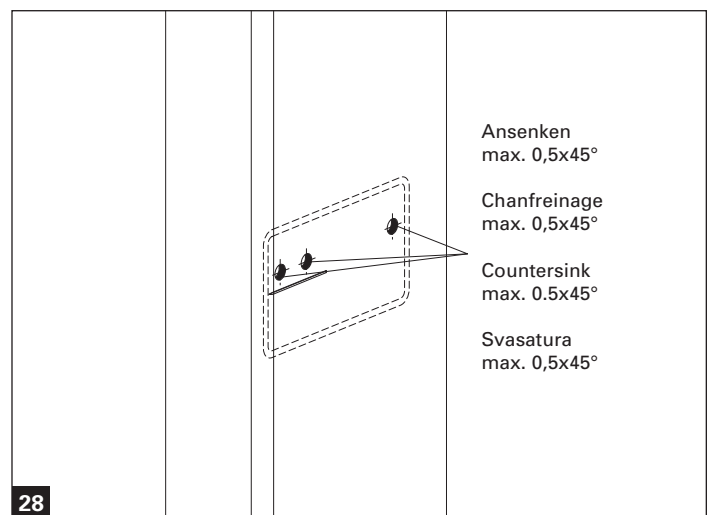
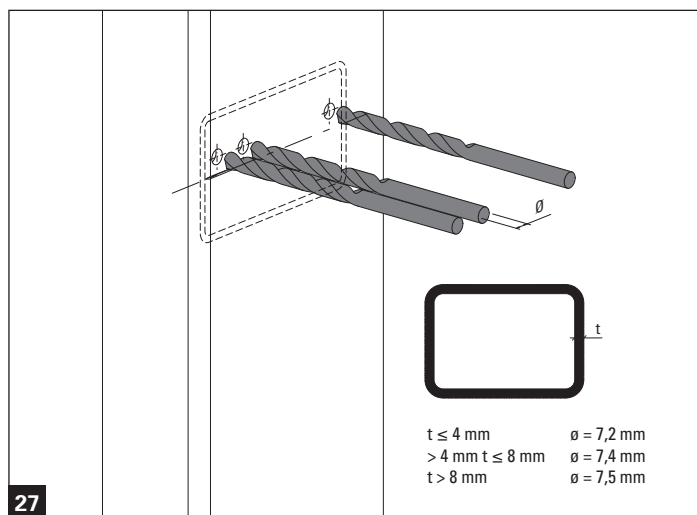
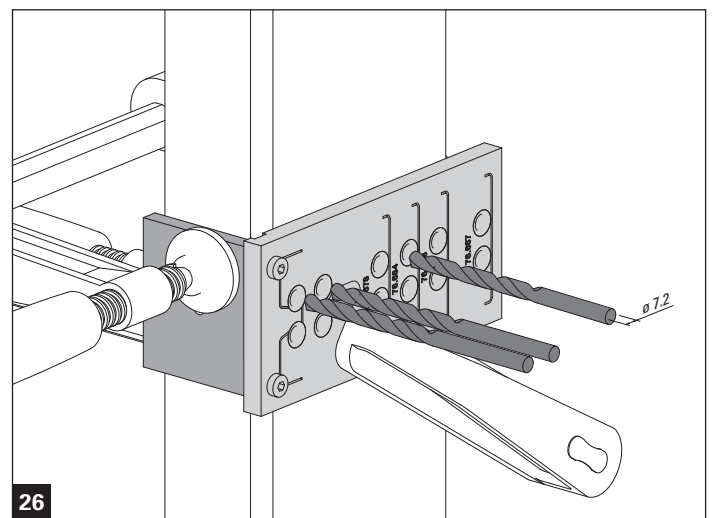
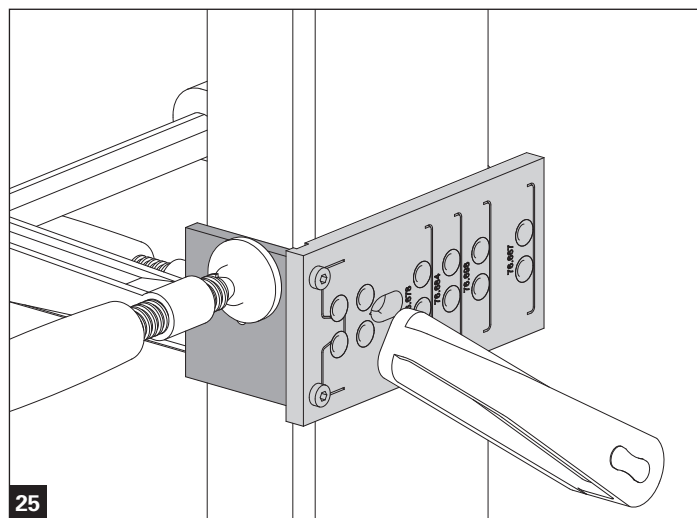
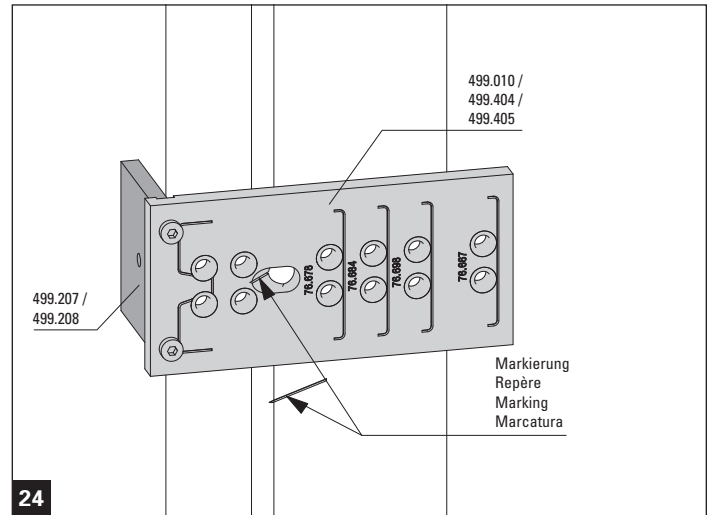
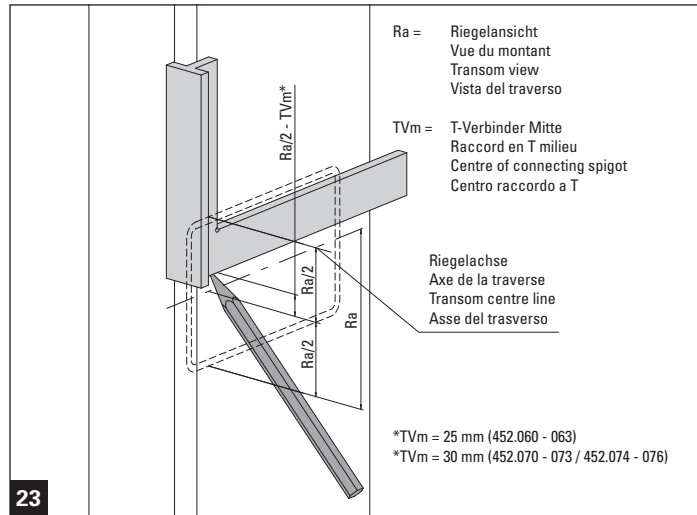

Schwerlast T-Verbinder einhängbar
Raccord en T charge lourde à suspendre
Heavy-duty clip-in connecting spigot
Raccordo a T per carichi elevati ad incastro

VISS Basic Tragkonstruktion
Construction porteuse VISS Basic
VISS Basic supporting structure
Struttura portante VISS Basic

Oberflächenbehandlung Tragkonstruktion

Nachdem die Pfosten und Riegel der Tragkonstruktion in der Werkstatt fertig erstellt sind, ist die Oberflächenbehandlung vorzunehmen.

Traitement de la surface de la construction porteuse

Il doit être procédé au traitement de surface quand les montants et traverses de la construction porteuse ont été réalisés à l'atelier..

Surface treatment of the load-bearing structure

After the mullion and transom of the load-bearing structure have been completed in the workshop, the surface treatment is to be applied.

Trattamento superficiale della struttura portante

Una volta che i montanti e i traversi della struttura portante sono stati realizzati in officina, è necessario provvedere al loro trattamento superficiale.

- 3. *Montage des Gegenstücks*
- 3. *Montage de la pièce correspondante*

- 3. *Assembly the counter part*
- 3. *Montaggio della contropiastra*

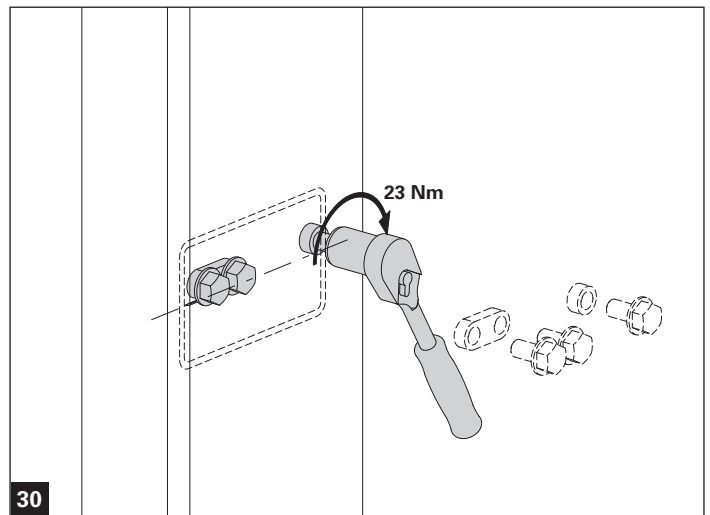
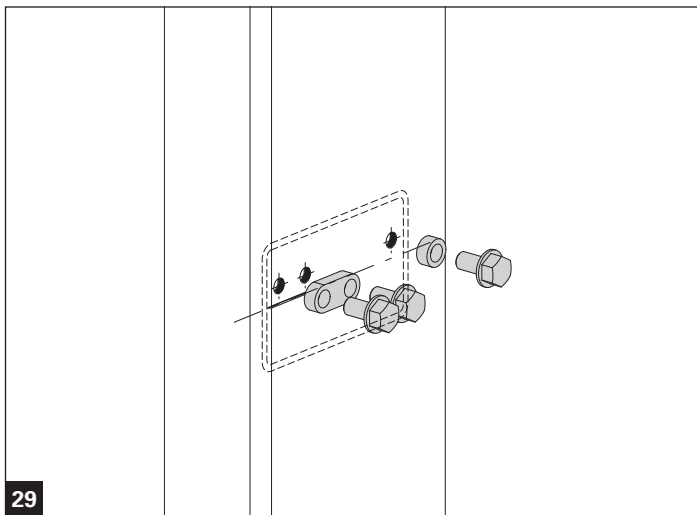

4. *Zuschnitt und Montage Pfostenschutz*
4. *Découpe et montage de la protection du montant*

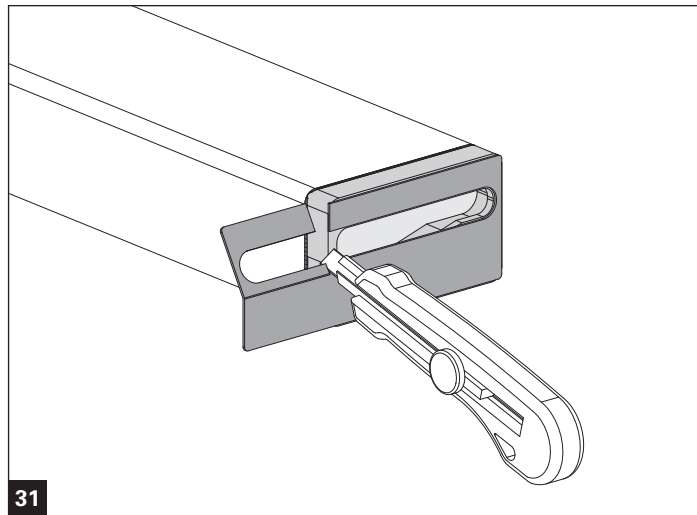

4. *Cutting and assembly the mullion protection*
4. *Taglio e applicazione della protezione del traverso*

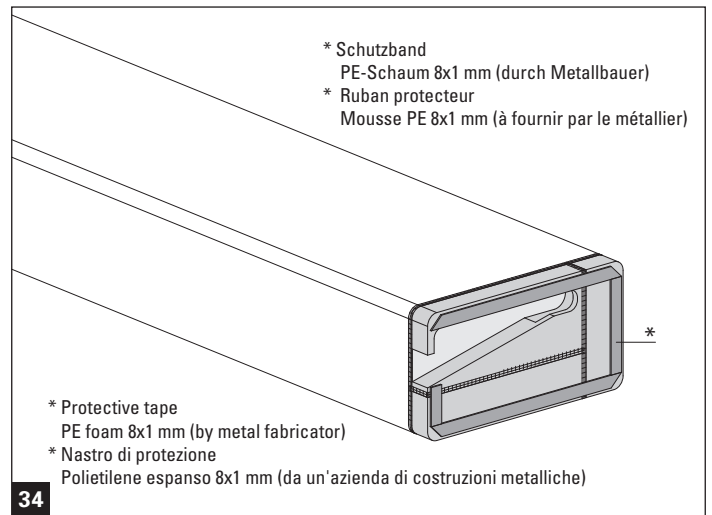
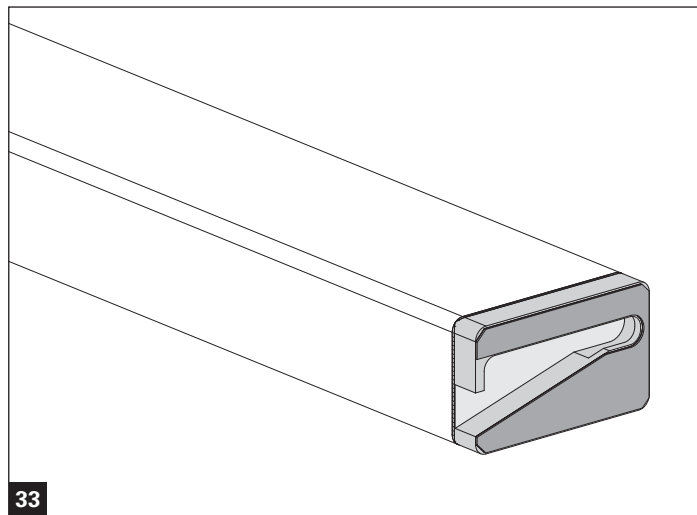
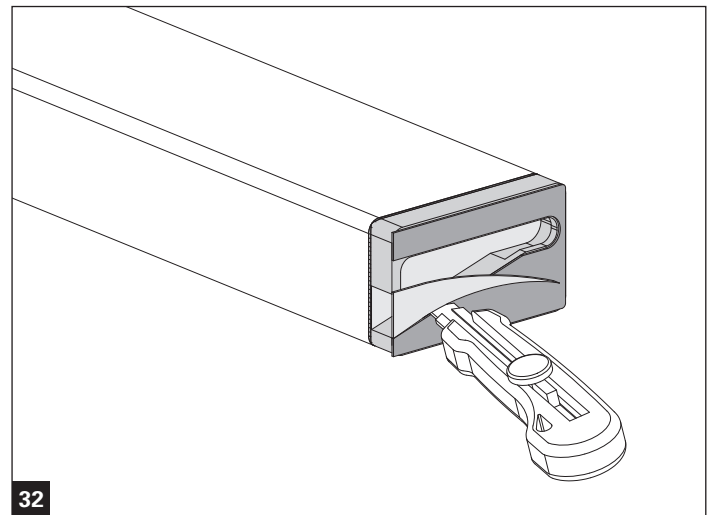

Hohlprofil mit Aufdoppelung
Profil creux avec doublage
Hollow profile with doubling
Profilo cavo con finitura

5. Montage
 5. Montage

5. Installation
 5. Montaggio

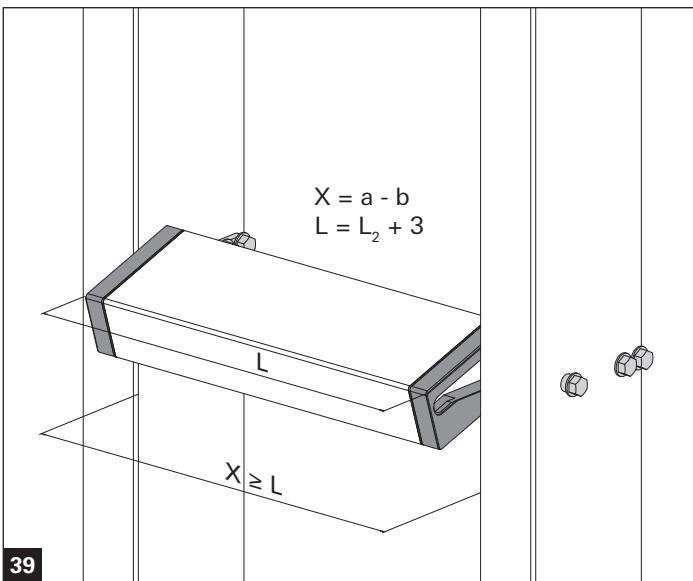
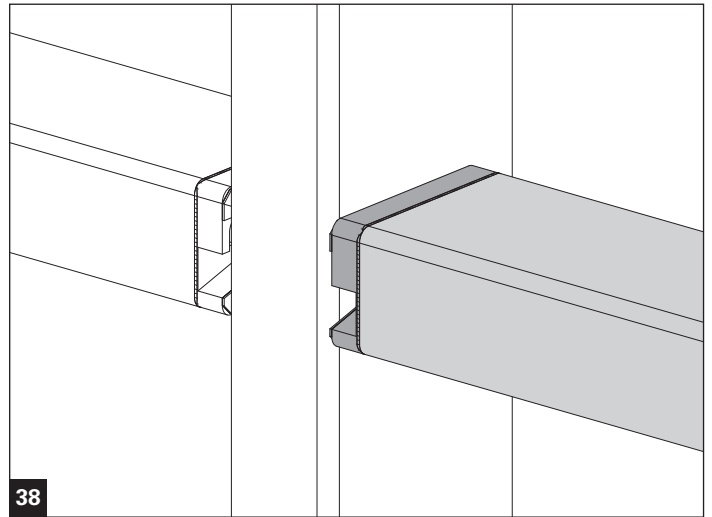
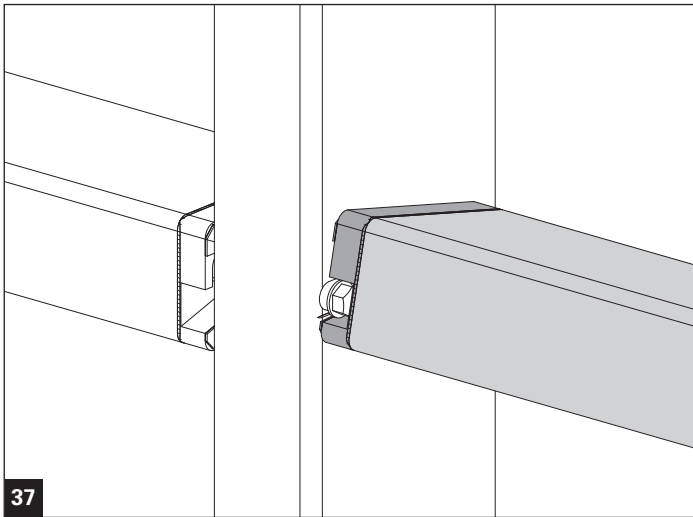
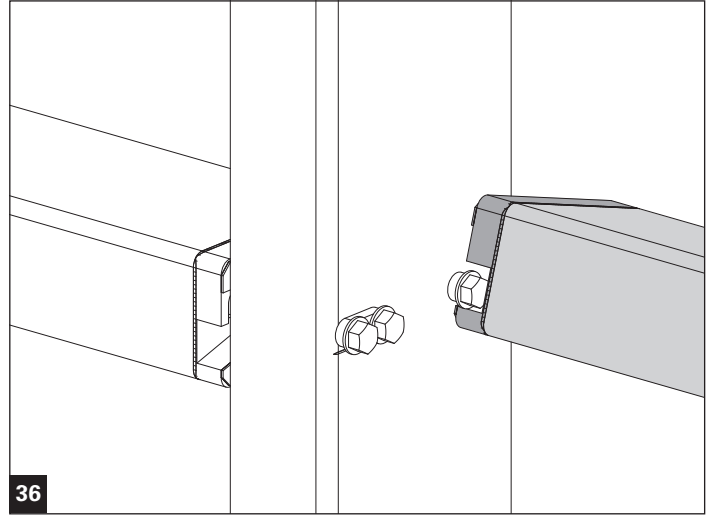
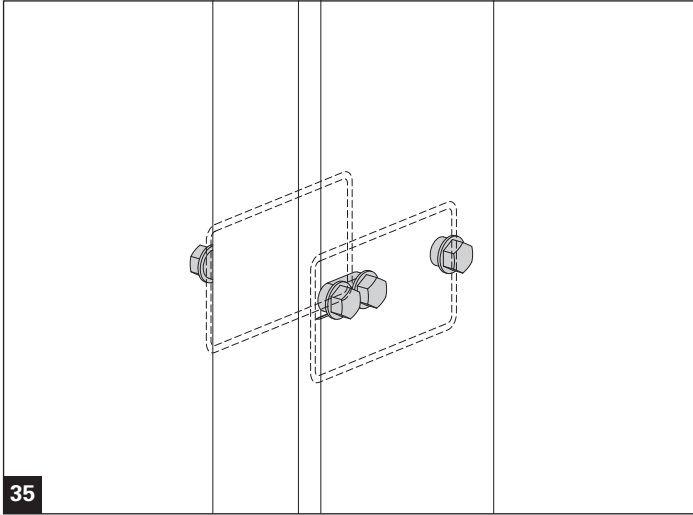

Bohrbild für CNC-Programmierung

Schéma de perçage pour programmation CNC

Drilling pattern for CNC programming

Piano di foratura per la programmazione CNC

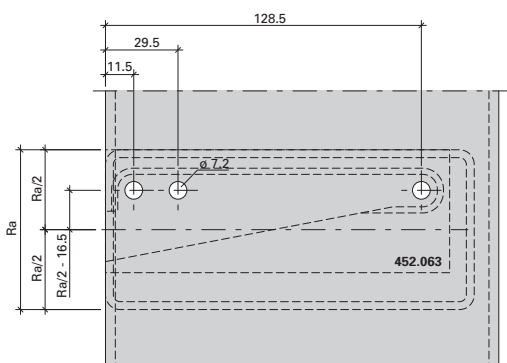
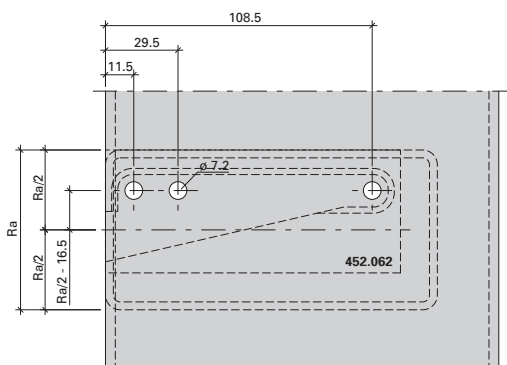
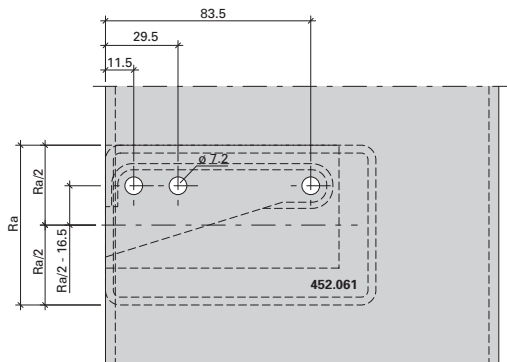
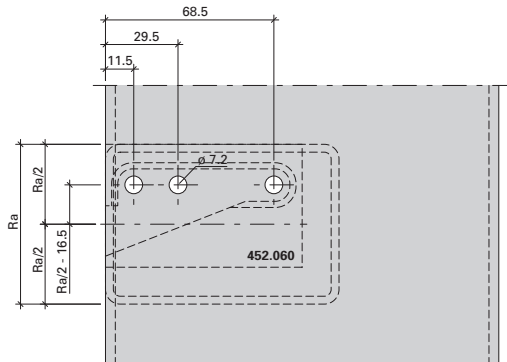

Schwerlast T-Verbinder einhängbar
Raccord en T charge lourde à suspendre
Heavy-duty clip-in connecting spigot
Raccordo a T per carichi elevati ad incastro

VISS Basic Tragkonstruktion
Construction porteuse VISS Basic
VISS Basic supporting structure
Struttura portante VISS Basic

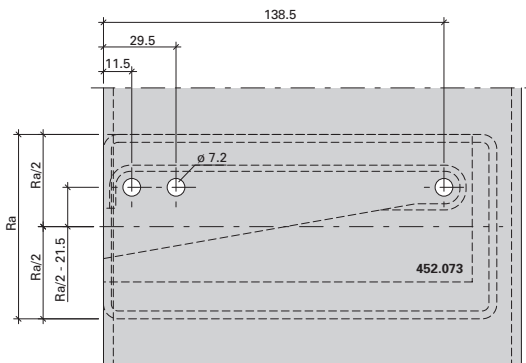
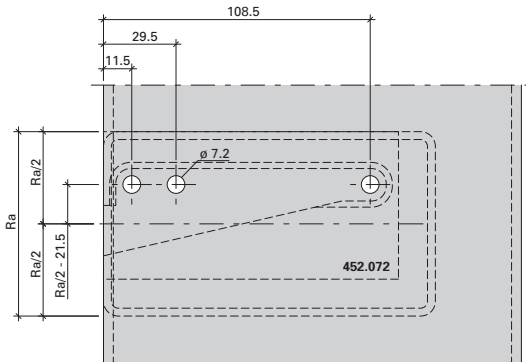
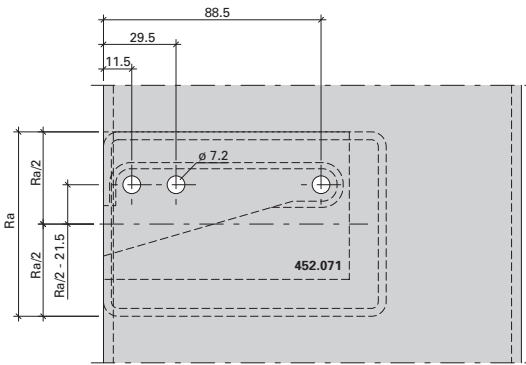
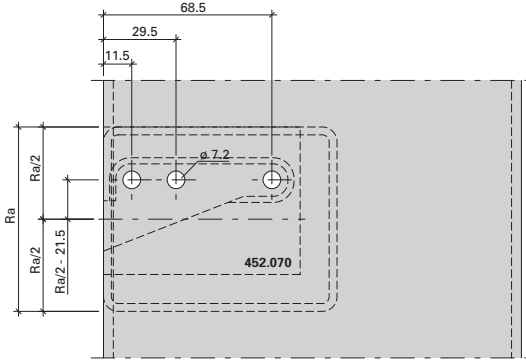

Schwerlast T-Verbinder einhängbar
Raccord en T charge lourde à suspendre
Heavy-duty clip-in connecting spigot
Raccordo a T per carichi elevati ad incastro

VISS Basic Tragkonstruktion
Construction porteuse VISS Basic
VISS Basic supporting structure
Struttura portante VISS Basic

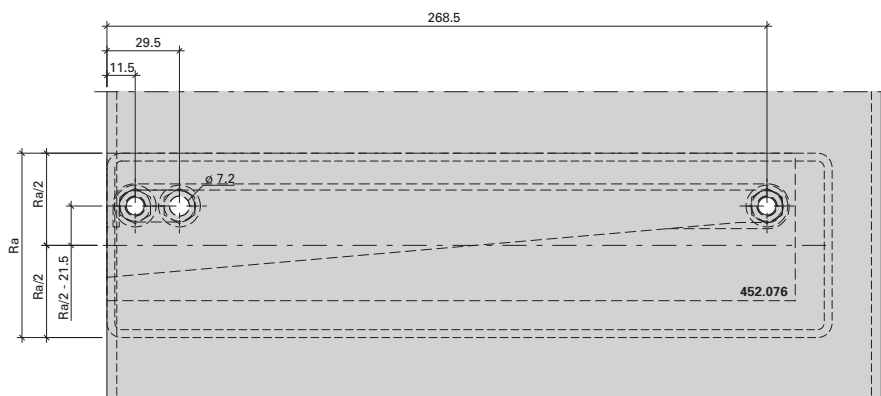
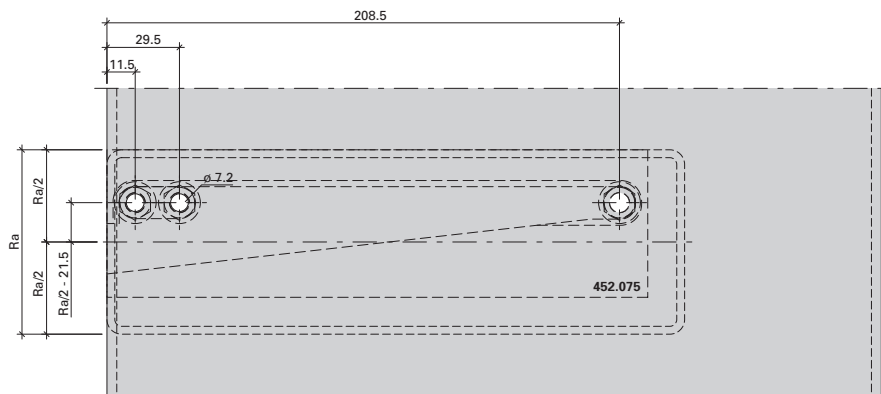
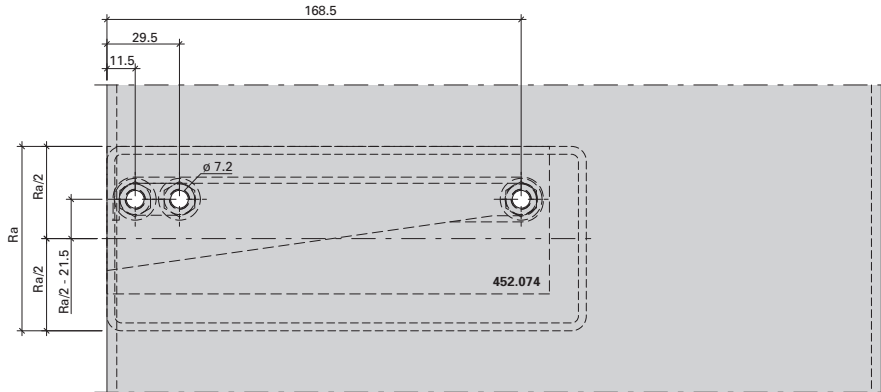

Elemente geschweisst
Éléments soudés
Welded units
Elementi saldati

VISS Basic Tragkonstruktion
Construction porteuse VISS Basic
VISS Basic supporting structure
Struttura portante VISS Basic

*Geschweisste Elemente sind bei folgenden
VISS Basic Systemen einsetzbar:*

*Welded units can be used in the
following VISS Basic systems:*

*Les éléments soudés sont utilisables sur les
systèmes VISS Basic suivants:*

*Gli elementi saldati possono essere utilizzati
con i seguenti sistemi VISS Basic:*

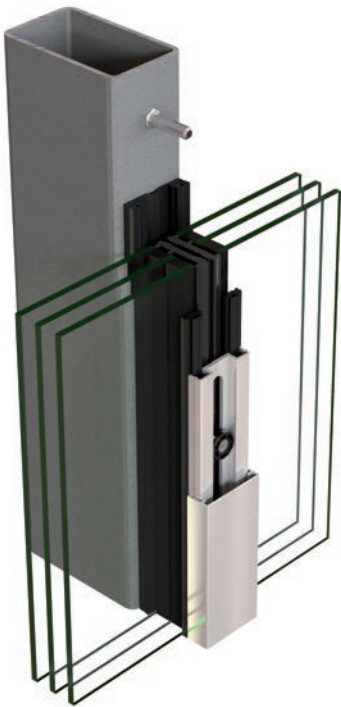

VISS Basic

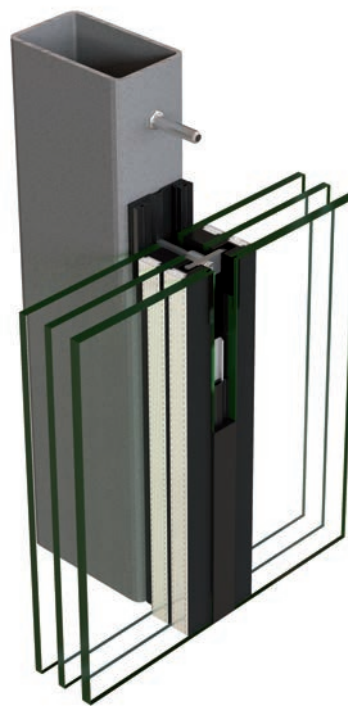

VISS Basic SG / VISS Basic Semi SG

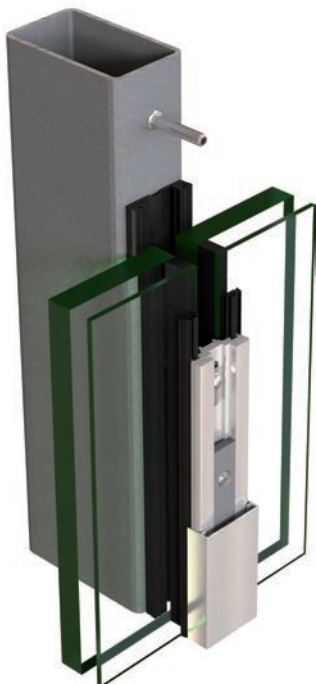

VISS Basic RC

Einsatzbereich geschweisste Elemente:

- Elemente mit ein- oder zweiseitig schräg geschnittenen Riegelverbindungen
- Elemente mit abgewickeltem Grundriss (z.B: konkav/konvex)
- Elemente mit biegesteifen Pfosten-/Riegelverbindungen
- Grossflächige Elemente, welche in der Werkstatt vorgefertigt werden

Area of application of welded units:

- Units with transom joints that are cut diagonally on one or both sides
- Units with curved floor plans (e.g. concave/convex)
- Units with structurally rigid mullion/transom joints
- Large units that are pre-fabricated in the workshop

Ablaufschritte:
Tragkonstruktion mit geschweissten Elementen

	Seite
1. Füllelementgewichte / Tragfähigkeit	36
2. Konstruktionen	32
3. Verarbeitung	37

Process steps:
Load-bearing structure with welded units

	Page
1. Infill unit weights/load-bearing capacity	36
2. Constructions	32
3. Processing	37

Domaine d'utilisation des éléments soudés:

- Éléments avec jonctions de traverse coupées obliquement d'un ou de deux côtés
- Éléments avec tracé développé (par ex. concave/convexe)
- Éléments avec jonction montant-traverse résistante à la flexion
- Éléments de grand format préfabriqués en atelier

Campo di impiego degli elementi saldati:

- Elementi con raccordi per traversi a taglio obliquo su uno o ambo i lati
- Elementi con pianta ad angolo (ad es.: concavo/convesso)
- Elementi con raccordi traverso/montante resistenti alla flessione
- Elementi di grande formato preassemblati in officina

Étapes du déroulement:
Construction porteuse avec éléments soudés

	Page
1. Poids de remplissage / charge admissible	36
2. Constructions	32
3. Usinage	37

Sequenza delle operazioni:
Struttura portante a elementi saldati

	Pagina
1. Pesi degli elementi di riempimento / capacità portante	36
2. Tipologie di costruzione	32
3. Lavorazione	37

Elemente geschweisst
 Eléments soudés
 Welded units
 Elementi saldati

VISS Basic Tragkonstruktion
 Construction porteuse VISS Basic
 VISS Basic supporting structure
 Struttura portante VISS Basic

Füllelementgewichte / Tragfähigkeit (G)

Weight of infill elements / Load capacity (G)

Poids de remplissage / Charge admissible (G)

Peso elemento di riempimento / Capacità portante (G)

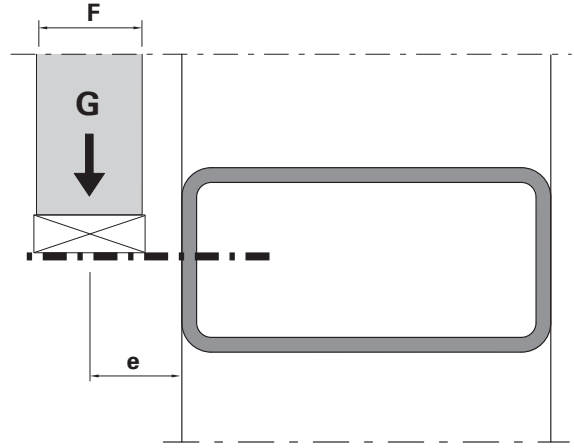
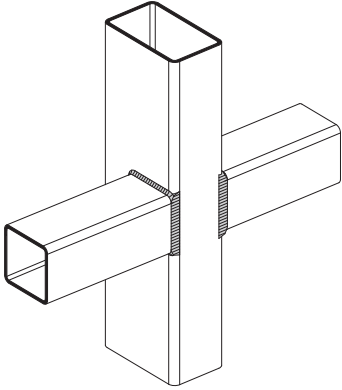

2x1 Traganker
 2x1 Boulons-supports
 2x1 Supporting bolts
 2x1 Bullone di supporto

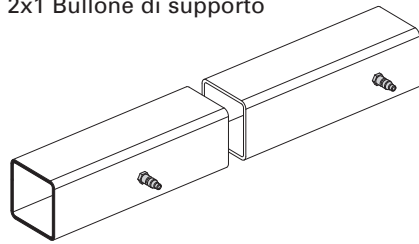

		50 mm		60 mm	
F	e	Dimension	G	Dimension	G
mm	mm	Dimension		Dimension	
		Dimension		Dimension	
		Dimensione		Dimensione	
6 - 45	45	min. 50/50/3 mm	0,75 kN	min. 60/60/3 mm	0,75 kN

2x2 Traganker
 2x2 Boulons-supports
 2x2 Supporting bolts
 2x2 Bullone di supporto

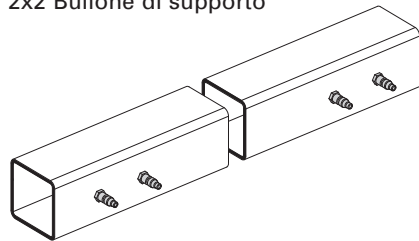

		50 mm		60 mm	
F	e	Dimension	G	Dimension	G
mm	mm	Dimension		Dimension	
		Dimension		Dimension	
		Dimensione		Dimensione	
6 - 45	45	min. 50/50/3 mm	1,5 kN	min. 60/60/3 mm	1,5 kN

2x3 Traganker
 2x3 Boulons-supports
 2x3 Supporting bolts
 2x3 Bullone di supporto

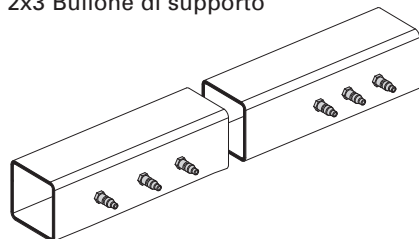

		50 mm		60 mm	
F	e	Dimension	G	Dimension	G
mm	mm	Dimension		Dimension	
		Dimension		Dimension	
		Dimensione		Dimensione	
6 - 45	45	min. 50/50/3 mm	3 kN	min. 60/60/3 mm	3 kN

Flachstahl eingeschweisst
 Acier plat soudé
 Flat steel welding
 Piastra in acciaio saldata

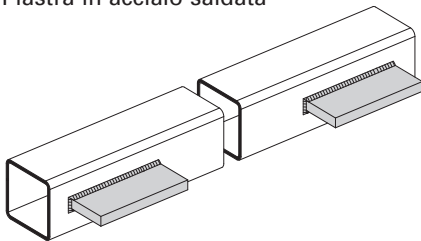

		50 mm		60 mm	
F	e	Dimension	G	Dimension	G
mm	mm	Dimension		Dimension	
		Dimensione		Dimensione	
6 - 40	30	min. 50/50/3 mm	13 kN	min. 60/60/3 mm	14 kN
41 - 55	37,5	min. 50/50/3 mm	11 kN	min. 60/60/3 mm	12 kN
56 - 70	45	min. 50/50/3 mm	9 kN	min. 60/60/3 mm	10 kN

Hinweis:

Die maximale Riegeldurchbiegung L/500 darf nicht überschritten werden und jegliche Berührung zwischen Riegel und Füllelement (Ausfachung) muss verhindert werden.

Werden die obigen Füllelementgewichte überschritten, so ist eine Prüfung im Einzelfall erforderlich.

Remarque:

Le flambage maximal de la traverse L/500 ne doit pas être dépassé et tout contact entre traverse et élément de remplissage (boulons-support et supports de vitrage) doit être empêché.

Si les poids de remplissage indiqués ci-dessus sont dépassés, un contrôle du cas particulier sera nécessaire.

Note:

The maximum transom deflection L/500 must not be exceeded and any contact between transom and infill unit (infill) must be prevented.

If the above infill unit weights are exceeded, an individual test is required.

Nota:

Non deve essere superata il valore massimo di flessione del traverso L/500 ed è necessario evitare qualsiasi contatto fra il traverso e l'elemento di riempimento (tamponamento).

Qualora i pesi degli elementi di riempimento riportati sopra vengano superati, sarà necessaria una verifica caso per caso.

Elemente geschweisst
Éléments soudés
Welded units
Elementi saldati

VISS Basic Tragkonstruktion
Construction porteuse VISS Basic
VISS Basic supporting structure
Struttura portante VISS Basic

Konstruktionen

Constructions

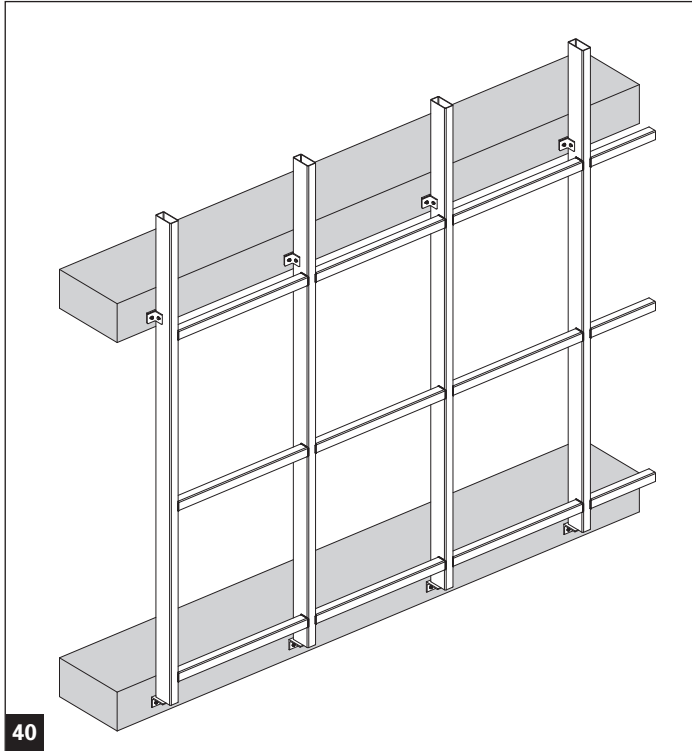

40
Rahmenbauweise Riegelverbindung geschweisst
Méthode de construction par éléments jonction soudée de la traverse
Unitised construction of welded transom joint
Costruzione a elementi con raccordo trasverso saldato

Constructions

Tipologie di costruzione



41
Segmentverglasung geschweisst
Vitrage segmenté soudé
Welded faceted glazing
Vetrare segmentate saldate

Verarbeitung

Usinage

1. Zuschnitt Riegel
1. Découpe traverse

Processing

Lavorazione

1. Transom cutting
1. Taglio dei traversi

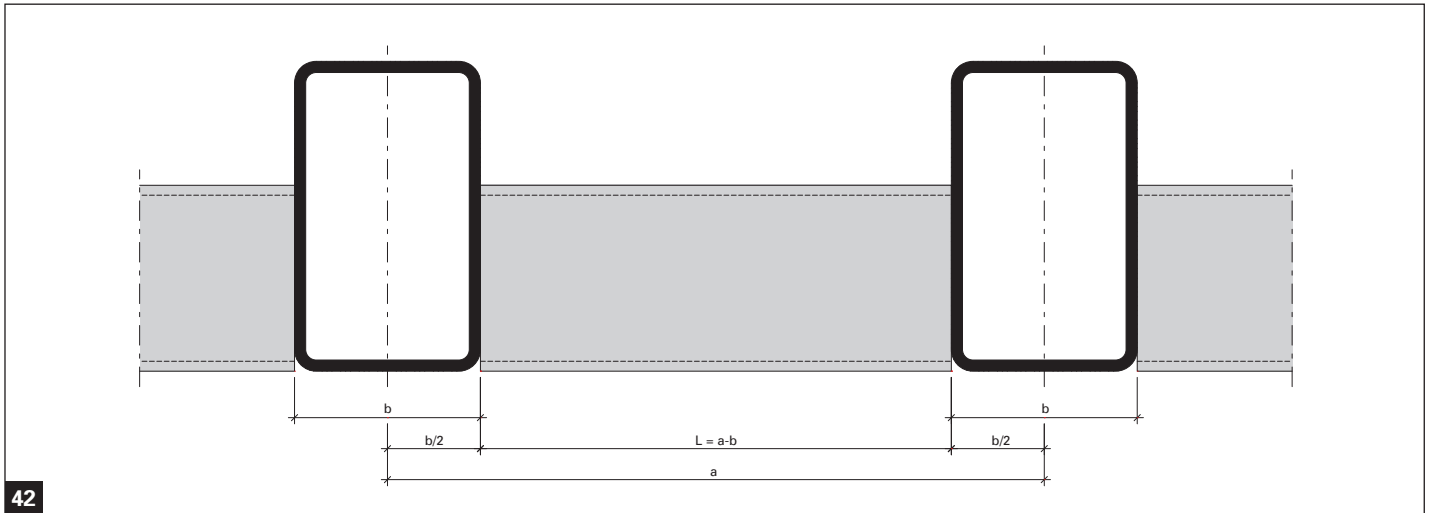

Länge Riegel $L = a - b$

a = Achsmass
 b = Profilbreite
 L = Riegellänge

Longueur traverse $L = a - b$

a = Entraxe
 b = Largeur du profilé
 L = Longueur de la traverse

Length of transom $L = a - b$

a = Axis dimension
 b = Profile width
 L = Transom length

Lunghezza traverso $L = a - b$

a = Interasse
 b = Larghezza profilo
 L = Lunghezza traverso

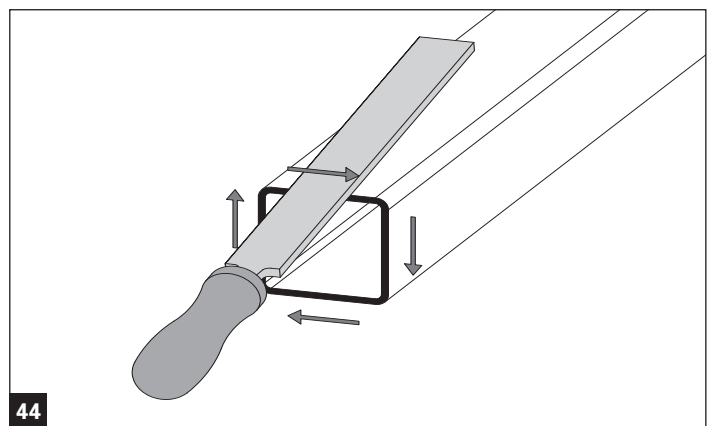
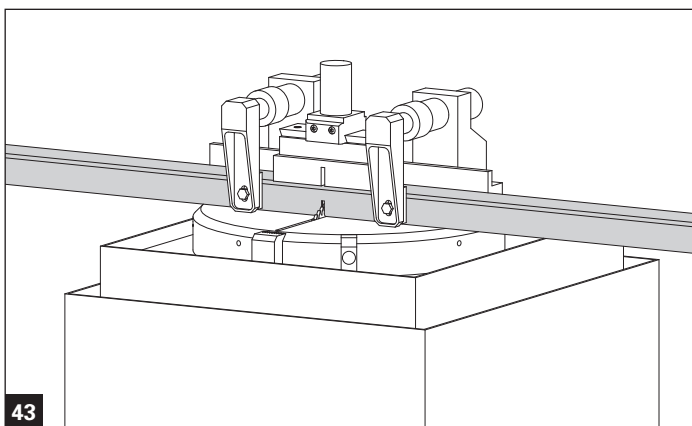

2. Riegel-/Pfostenverbindung geschweisst
2. Jonction traverse-montant soudée

2. Welded transom/mullion joint
2. Raccordo traverso/montante saldato

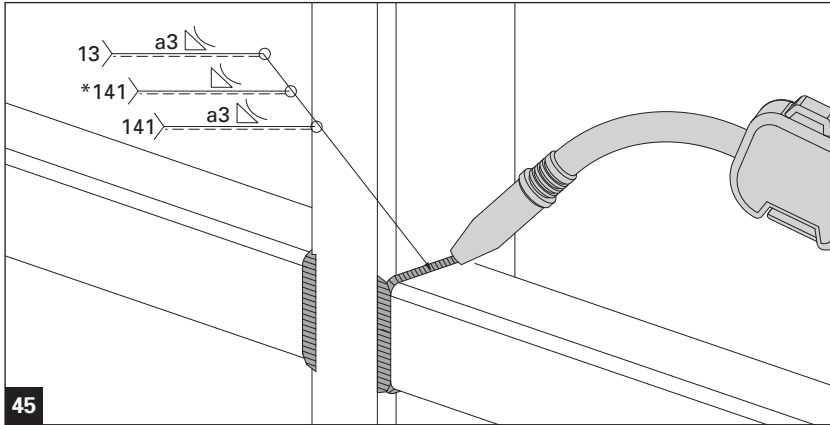

Schweisssnaht Riegelverbindung umlaufend, Stärke der Schweisssnaht entsprechend statischen Anforderungen (mindestens jedoch $t = 3 \text{ mm}$)

Cordon de soudure périphérique de la jonction de la traverse, épaisseur du cordon en fonction des exigences statiques (cependant au moins $t = 3 \text{ mm}$)

Weld seam on all sides of transom joint, strength of weld seam in accordance with structural requirements (however $t =$ at least 3 mm)

Raccordo del traverso con cordone di saldatura perimetrale, spessore del cordone a seconda dei requisiti statici (tuttavia almeno pari a $t = 3 \text{ mm}$)

Variante Schweissverfahren

Für hohe ästhetische Anforderungen an die Schweisssnähte ist allenfalls das TIG/WIG Schweissverfahren zu empfehlen. Dieses Verfahren ergibt sehr feine und gleichmässige Schweisssnähte. Die TIG/WIG Schweissung ist insbesondere auch dann zu empfehlen, wenn Einselelemente eingesetzt werden, welche mit wenig Spiel einzubauen sind.

* Hinweis:

Werden die mittels TIG/WIG eingeschweissten Riegel erhöhten statischen Belastungen ausgesetzt, so ist durch den Metallbauer zu prüfen ob die TIG/WIG-Schweisssnähte diese Belastungen aufnehmen können.

Variante de procédé de soudage

Le procédé de soudage TIG/WIG peut être recommandé pour les exigences esthétiques de grande qualité. Ce procédé fournit des cordons de soudure très fins et réguliers. Le soudage TIG/WIG est également en particulier recommandé quand des éléments de remplissage qui doivent être montés sans disposer de beaucoup de jeu sont utilisés.

* Remarque:

Si les traverses soudées au moyen du procédé TIG/WIG sont soumises à des charges statiques élevées, le constructeur métallique devra vérifier que les cordons de soudure TIG/WIG sont en mesure de les absorber.

Welding method options

For weld seams with high aesthetic requirements, the TIG/WIG welding method is recommended. This method results in very fine and even weld seams. The TIG/WIG welding method is recommended in particular when insert units are used, which should be installed with very little play.

* Note:

If increased structural loads are applied by means of TIG/WIG welded transoms, the metal fabricator must check whether the TIG/WIG weld seams can accommodate these loads.

Variante procedimento con saldatura

Qualora i cordoni di saldatura debbano rispondere a elevati requisiti estetici si consiglia eventualmente di ricorrere al procedimento di saldatura TIG/WIG, che consente di ottenere cordoni molto sottili e omogenei. La saldatura TIG/WIG è consigliabile in particolare anche in tutti quei casi in cui vengono impiegati elementi da montare con pochissimo gioco.

* Nota:

Se i traversi saldati con il procedimento TIG/WIG devono essere sottoposti a carichi statici elevati, l'azienda di costruzioni metalliche dovrà verificare se i cordoni di saldatura così realizzati sono in grado di sopportare detti carichi.

3. Riegel-/Pfostenverbindung Segmentverglasung geschweisst
3. Jonction traverse-montant vitrage segmenté soudé

3. Welded transom/mullion joint for faceted glazing
3. Raccordo traverso/montante vetrata segmentata saldato

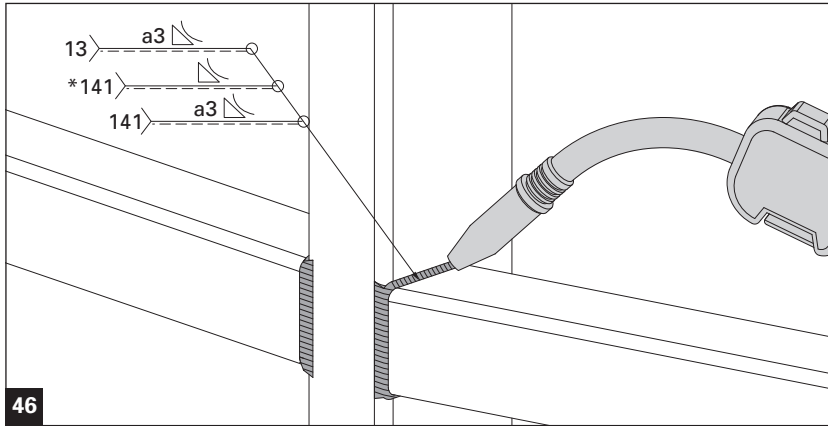

Schweißnaht Riegelverbindung Segmentverglasung umlaufend, Stärke der Schweißnaht entsprechend statischen Anforderungen (mindestens jedoch $t = 3 \text{ mm}$)

Cordon de soudure jonction montant-traverse vitrage segmenté périphérique, épaisseur du cordon en fonction des exigences statiques (cependant au moins $t = 3 \text{ mm}$)

Weld seam on all sides of transom joint for faceted glazing, strength of weld seam in accordance with structural requirements (however $t =$ at least 3 mm)

Raccordo del traverso di vetrata segmentata con cordone di saldatura perimetrale, spessore del cordone a seconda dei requisiti statici (tuttavia almeno pari a $t = 3 \text{ mm}$)

Variante Schweissverfahren

Für hohe ästhetische Anforderungen an die Schweißnähte ist allenfalls das TIG/WIG Schweissverfahren zu empfehlen. Dieses Verfahren ergibt sehr feine und gleichmässige Schweißnähte. Die TIG/WIG Schweissung ist insbesondere auch dann zu empfehlen, wenn Einzelelemente eingesetzt werden, welche mit wenig Spiel einzubauen sind.

* Hinweis:

Werden die mittels TIG/WIG eingeschweissten Riegel erhöhten statischen Belastungen ausgesetzt, so ist durch den Metallbauer zu prüfen ob die TIG/WIG-Schweißnähte diese Belastungen aufnehmen können.

Variante de procédé de soudage

Le procédé de soudage TIG/WIG peut être recommandé pour les exigences esthétiques de grande qualité. Ce procédé fournit des cordons de soudure très fins et réguliers. Le soudage TIG/WIG est également en particulier recommandé quand des éléments de remplissage qui doivent être montés sans disposer de beaucoup de jeu sont utilisés.

* Remarque:

Si les traverses soudées au moyen du procédé TIG/WIG sont soumises à des charges statiques élevées, le constructeur métallique devra vérifier que les cordons de soudure TIG/WIG sont en mesure de les absorber.

Welding method options

For weld seams with high aesthetic requirements, the TIG/WIG welding method is recommended. This method results in very fine and even weld seams. The TIG/WIG welding method is recommended in particular when insert units are used, which should be installed with very little play.

* Note:

If increased structural loads are applied by means of TIG/WIG welded transoms, the metal fabricator must check whether the TIG/WIG weld seams can accommodate these loads.

Variante procedimento con saldatura

Qualora i cordoni di saldatura debbano rispondere a elevati requisiti estetici si consiglia eventualmente di ricorrere al procedimento di saldatura TIG/WIG, che consente di ottenere cordoni molto sottili e omogenei. La saldatura TIG/WIG è consigliabile in particolare anche in tutti quei casi in cui vengono impiegati elementi da montare con pochissimo gioco.

* Nota:

Se i traversi saldati con il procedimento TIG/WIG devono essere sottoposti a carichi statici elevati, l'azienda di costruzioni metalliche dovrà verificare se i cordoni di saldatura così realizzati sono in grado di sopportare detti carichi.

4. Riegelschweissung mit schräg eingebautem Riegel
4. Soudage avec traverse montée obliquement

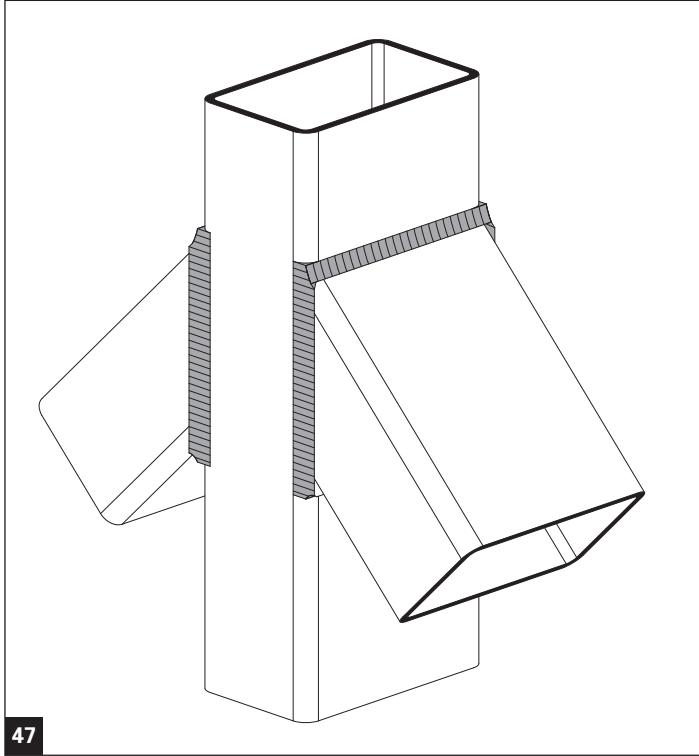

4. Transom welding with transom installed diagonally
4. Saldatura del traverso con traverso montato obliquo

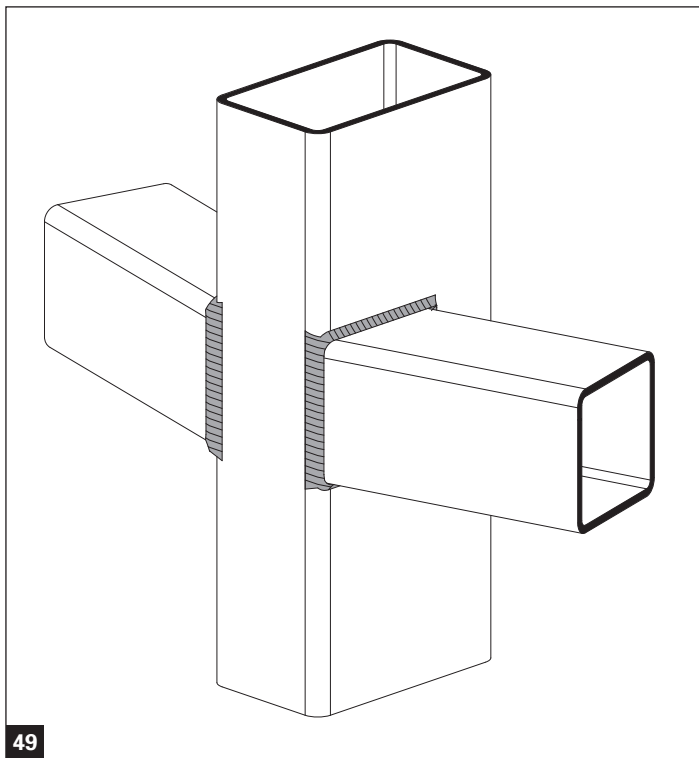
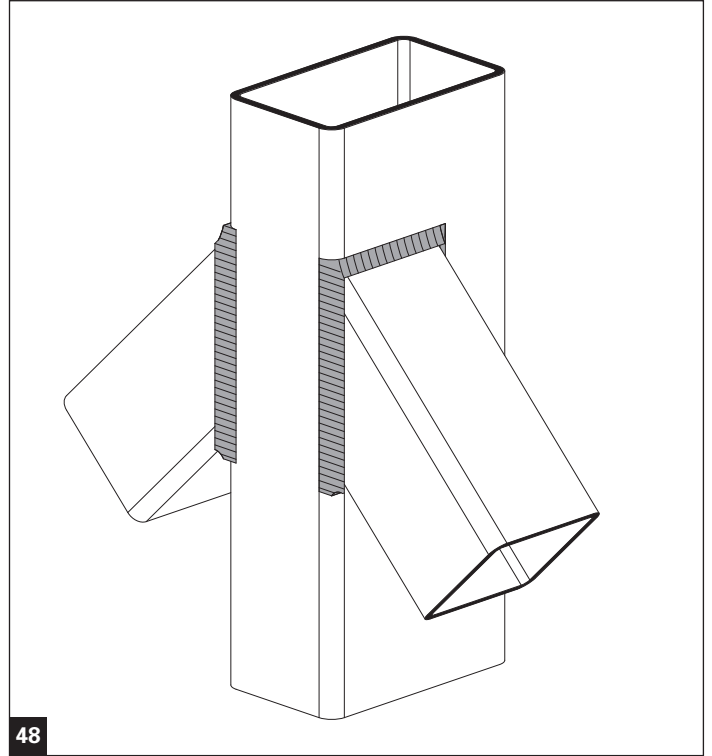

5. Schweissung Pfosten-Rahmen-Verbindung
5. Soudage jonction montant-cadre

5. Welding of mullion/frame joint
5. Saldatura del raccordo montante-telaio

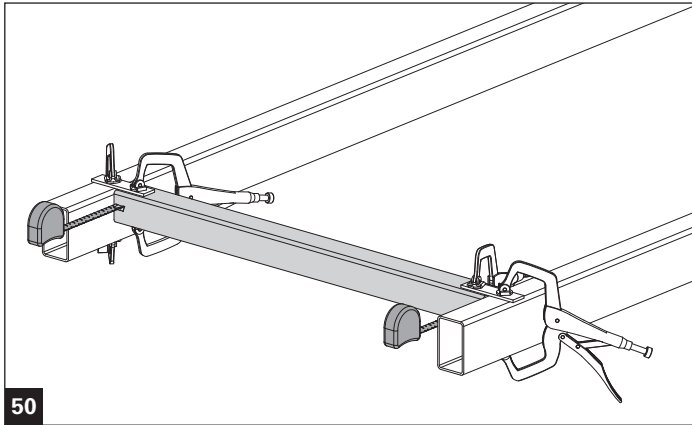

Riegel einmessen und festklemmen
Mesurer la traverse et la bloquer
Measure transom and fix in place
Misurare il traverso, quindi fissarlo

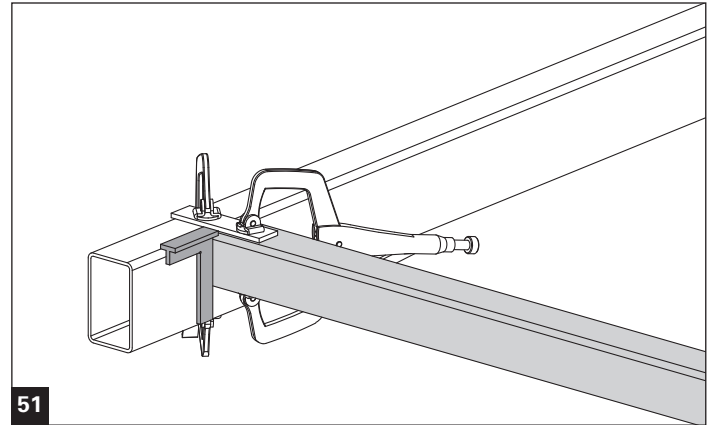

Riegel im Winkel ausrichten und festklemmen
Aligner la traverse à angle droit et la bloquer
Align transom at an angle and fix into place
Allineare gli angoli del traverso, quindi fissarlo

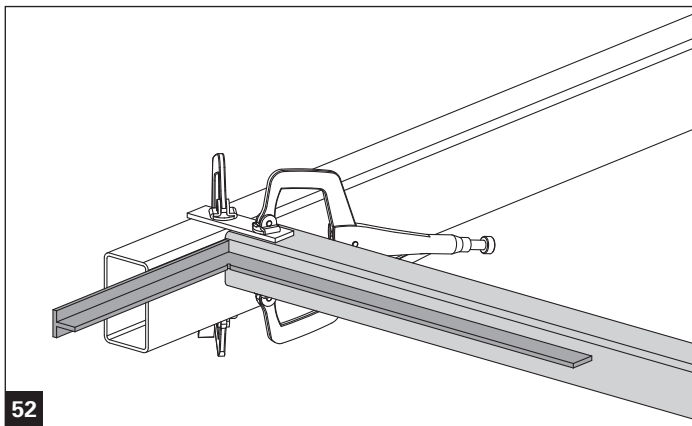

Rahmen rechtwinklig ausrichten
Aligner le cadre à angle droit
Align frame at a right angle
Allineare gli angoli del telaio a 90°

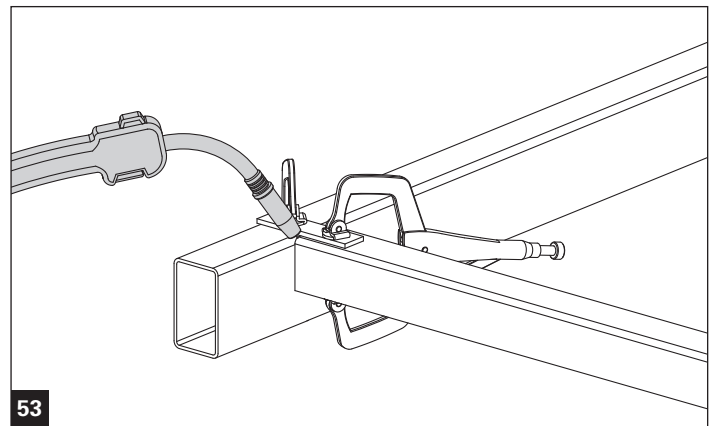

Riegel mittels örtlicher Schweissung provisorisch heften
Pointer provisoirement la traverse par un soudage local
Temporarily attach transom by means of local welding
Fissare provvisoriamente il traverso con dei punti di saldatura

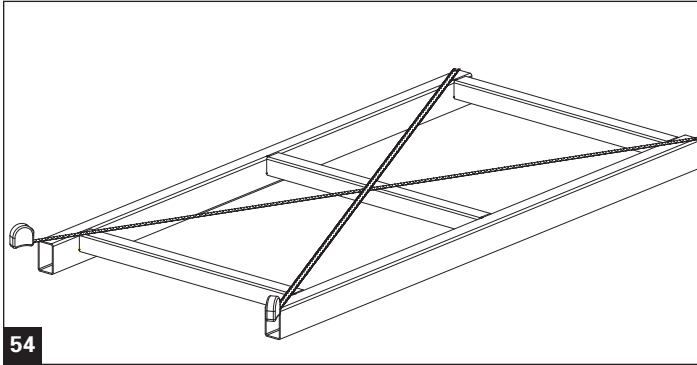

54

Diagonale ausmessen und evtl. nachrichten
Mesurer la diagonale et aligner de nouveau si nécessaire
Measure the diagonals and realign if necessary
Misurare le diagonali e se necessario correggerle

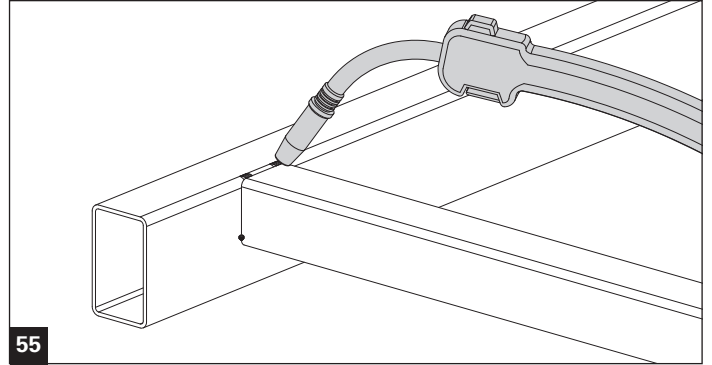

55

Haftschweissung an 4 Eckpunkten
Soudage par points à 4 points angulaires
Tack welding at 4 corner points
Fissare saldando sui quattro angoli

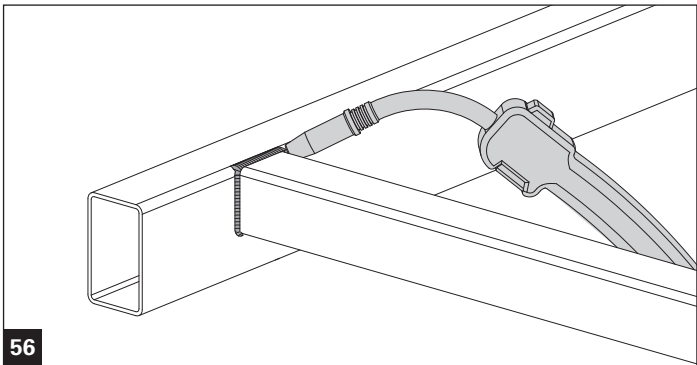

56

Riegel vorne und seitlich schweissen
Soudier la traverse à l'avant et sur le côté
Weld transom at the front and at the side
Saldare il traverso anteriormente e lateralmente

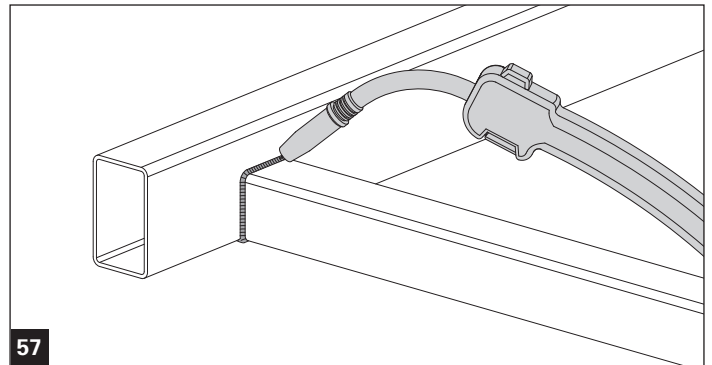

57

Riegel auf Rückseite fertig schweissen und Rahmen richten
Terminer de souder la traverse en face arrière et redresser le cadre
Finally, weld transom on the rear side and align frame
Completare quindi la saldatura sul lato posteriore e allineare il telaio

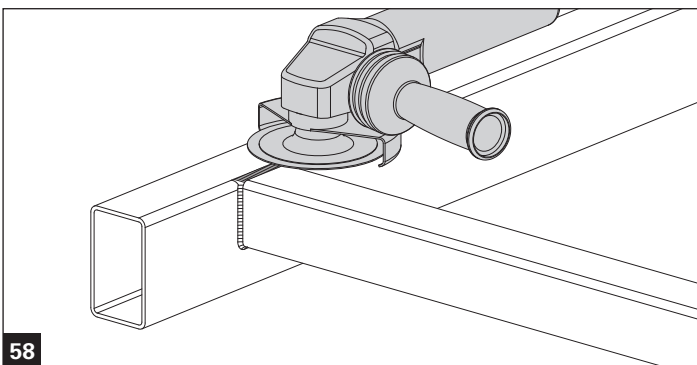

58

Schweißnaht vorne im Nutbereich verschleifen
Polir le cordon de soudure à l'avant dans la zone de la rainure
Grind weld seam on the front in the groove area
Levigare il cordone di saldatura anteriormente in corrispondenza della scanalatura

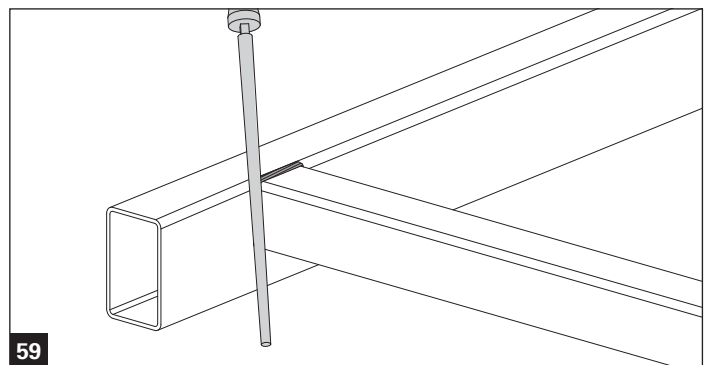

59

Kanten nachfeilen/verputzen
Limer/nettoyer les arrêtes
File down/clean edges
Limare/pulire i bordi

Ausführungsbeispiele

	Seite
1. Ausführungsbeispiele Fussplatten	44
2. Ausführungsbeispiele Kopfplatten/ stirnseitige Befestigungen	45
3. Befestigungsbeispiele Fusspunkte	46
4. Befestigungsbeispiele Kopfpunkte/ Zwischendecken	47
5. Abdichtungsbeispiele Fusspunkte/Kopfpunkte	48
6. Abdichtung Tragkonstruktion	49

Design examples

	Page
1. Base plate design examples	44
2. Top plate/front end fixing design examples	45
3. Base point fixing examples	46
4. Top point/intermediate floor fixing examples	47
5. Base point/top point sealing examples	48
6. Sealing of load-bearing structure	49

Exemples d'exécution

	Page
1. Exemples d'exécution semelles	44
2. Exemples d'exécution tôles de recouvrement/fixations en face avant	45
3. Exemples de fixation des appuis inférieurs	46
4. Exemples de fixation appuis supérieurs/ plafonds intermédiaires	47
5. Exemples d'étanchéification appuis inférieurs/ appuis supérieurs	48
6. Étanchéification de la construction porteuse	49

Esempi di realizzazione

	Pagina
1. Esempi di realizzazione delle piastre di base	44
2. Esempi di realizzazione delle piastre di testa/fissaggi frontali	45
3. Esempi di fissaggio dei punti di base	46
4. Esempi di fissaggio punti di testa/ solai intermedi	47
5. Esempi di impermeabilizzazione punti di base/ punti di testa	48
6. Impermeabilizzazione struttura portante	49

1. Ausführungsbeispiele Fussplatten
1. Exemples d'exécution semelles

1. Base plate design examples
1. Esempi di realizzazione delle piastre di base

Beispiel Fussplatte geschweisst
Exemple semelle soudée
Example of welded base plate
Esempio di piastra di base saldata

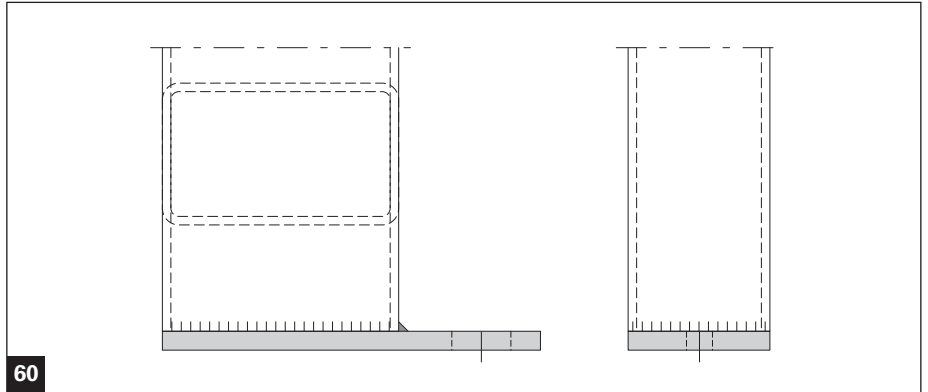

Beispiel Fussplatte geschweisst
Exemple semelle soudée
Example of welded base plate
Esempio di piastra di base saldata

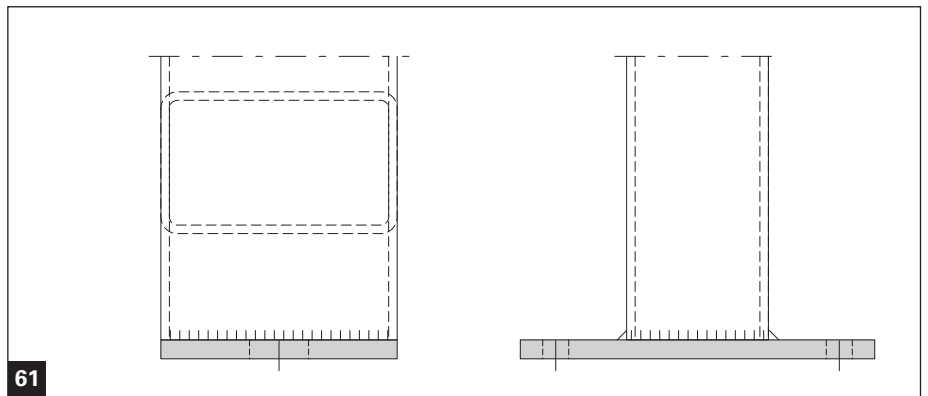

Beispiel Fussplatte geschweisst
(statisch eingespannt)
Exemple semelle soudée
(serrée du point de vue statique)
Example of welded base plate
(structurally fixed)
Esempio di piastra di base saldata
(con bloccaggio statico)

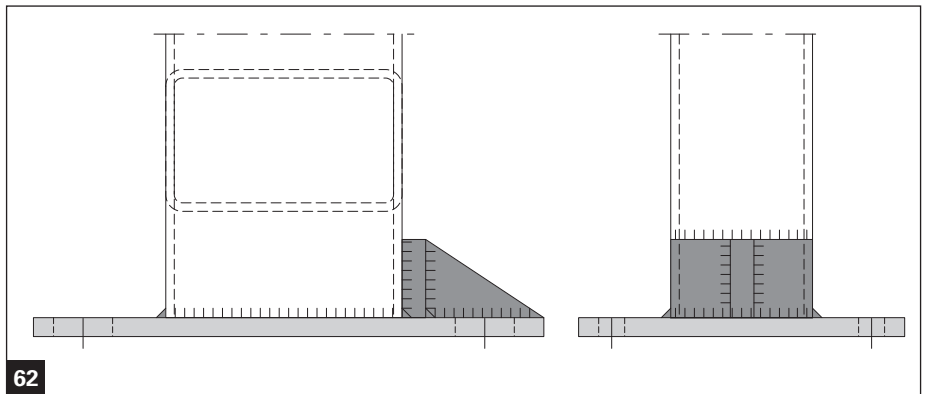

Beispiel Fussplatte
gesteckt/geschraubt
Exemple semelle
emboîtée/vissée
Example of
pushed-on/screwed-in base plate
Esempio di piastra di base
innestata/avvitata

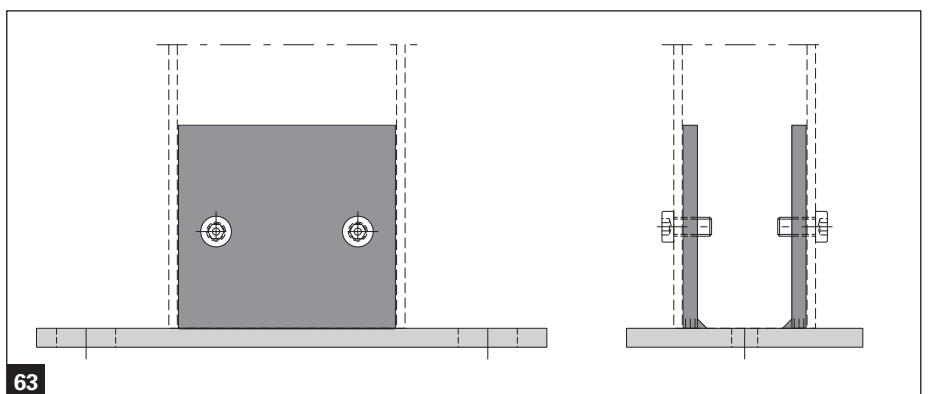

2. Ausführungsbeispiele Kopfplatten
 2. Exemples tôles de recouvrement

2. Top plate examples
 2. Esempi di realizzazione delle piastre di testa

Beispiel Kopfplatte für Deckenuntersicht (beweglich)

Exemple tôle de recouvrement pour sous-face du plafond (mobile)

Example of top plate for underside of slab (moveable)

Esempio di piastra di testa per lato inferiore solaio (amovibile)

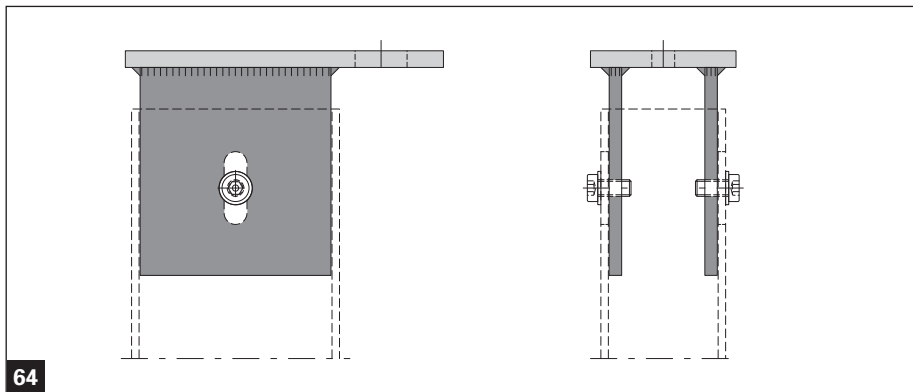

64

Beispiel Kopfplatte für Deckenuntersicht (beweglich)

Exemple tôle de recouvrement pour sous-face du plafond (mobile)

Example of top plate for underside of slab (moveable)

Esempio di piastra di testa per lato inferiore solaio (amovibile)

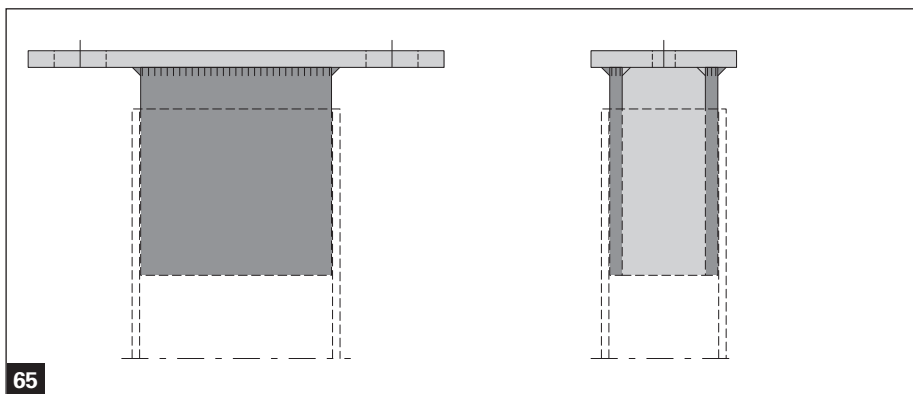

65

Beispiel Befestigung auf Deckenstirnseite (beweglich)

Exemple fixation sur face avant du plafond (mobile)

Example of fastening on front side of slab (moveable)

Esempio di fissaggio su lato frontale solaio (amovibile)

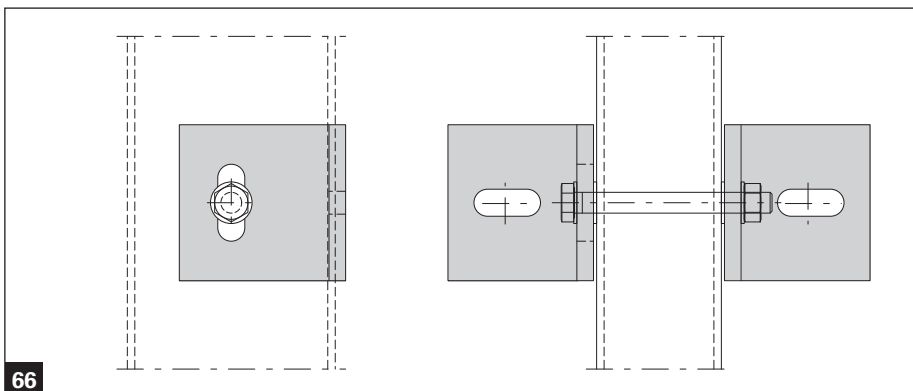

66

Beispiel Befestigung auf Fix- und Lospunkt – Deckenstirnseite

Exemple fixation sur (point fixe et point non fixe – face avant du plafond)

Example of fastening on fixing point and sliding bearing point – front side of slab

Esempio di fissaggio su – 1 punto fisso e 1 mobile lato frontale solaio

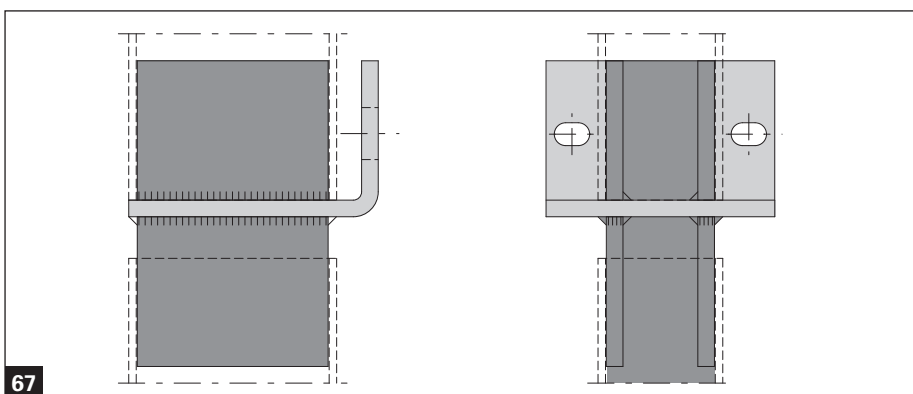

67

3. *Befestigungsbeispiele Fusspunkte*
3. *Exemples de fixation appuis inférieurs*

3. *Base point fixing examples*
3. *Esempi di fissaggio dei punti di base*

Beispiel Fusspunkt auf
Betonboden montiert
Exemple appui inférieur monté
sur plancher en béton
Example of base point mounted
on concrete floor
Esempio punto di base montato
su fondo in cs

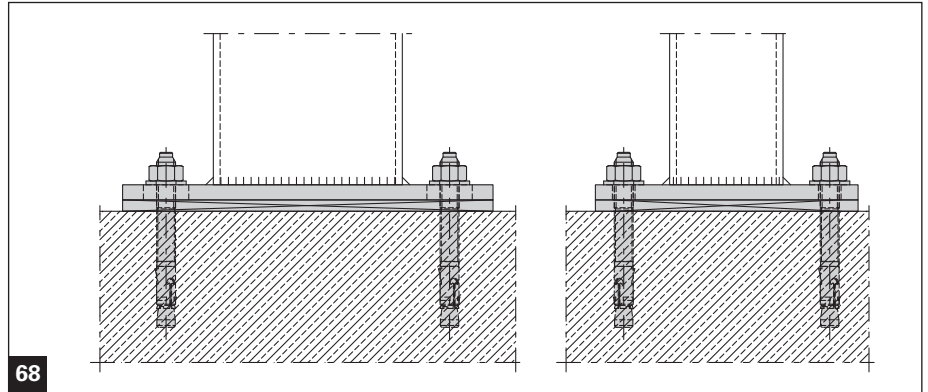

68

Beispiel Fusspunkt auf
Betonstirnseite montiert
Exemple appui inférieur monté
sur face avant en béton
Example of base point mounted
on front side of concrete
Esempio punto di base montato
su lato frontale in cs

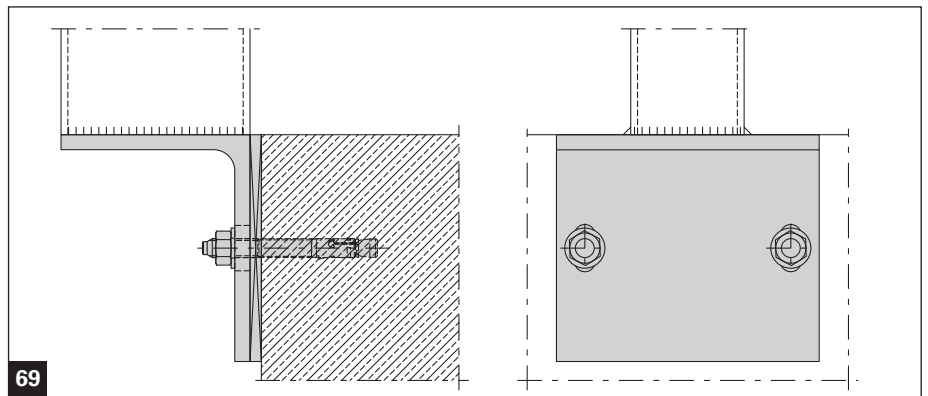

69

Beispiel Fusspunkt auf
Betonstirnseite montiert
Exemple appui inférieur monté
sur face avant en béton
Example of base point mounted
on front side of concrete
Esempio punto di base montato
su lato frontale in cs

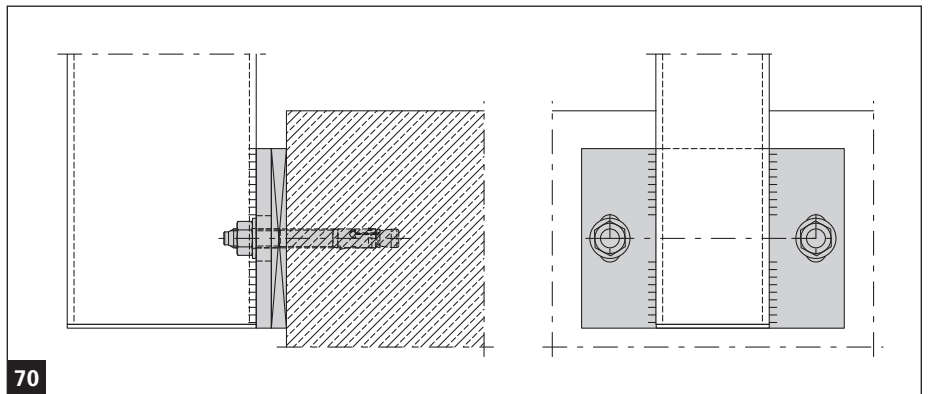

70

Beispiel Fusspunkt einhängbar
(auf vormontierte Winkelplatte)
Exemple appui inférieur à suspendre
(sur plaque angulaire pré-montée)
Example of clip-in base point
(on pre-assembled angle plate)
Esempio punto di base a incastro
(su piastra angolare premontata)

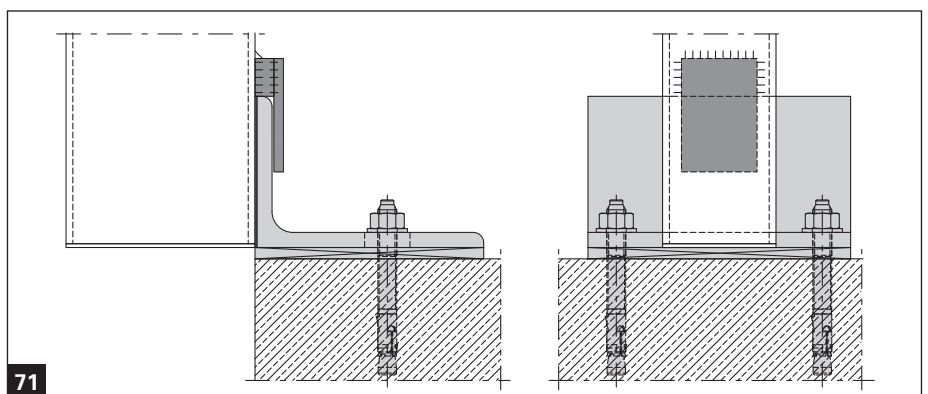

71

4. Befestigungsbeispiele Kopfpunkte / Zwischendecken
 4. Exemples de fixation appuis supérieurs/
 plafonds intermédiaires

4. Top points/intermediate floor fixing examples
 4. Esempi di fissaggio punti di testa/solai intermedi

Beispiel Kopfplatte auf
 Deckenuntersicht montiert

Exemple tôle de recouvrement
 montée sur sous-face du plafond

Example of top plate mounted
 on underside of slab

Esempio punto di testa montato
 su lato inferiore solaio

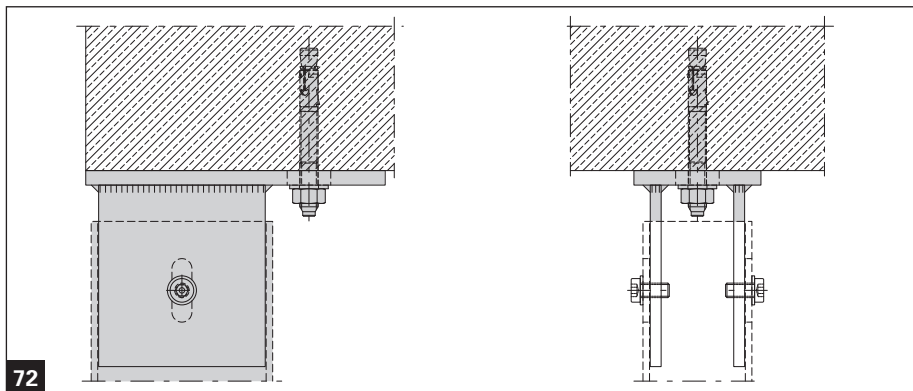

72

Beispiel Kopfplatte auf
 Deckenuntersicht montiert

Exemple tôle de recouvrement
 montée sur sous-face du plafond

Example of top plate mounted
 on underside of slab

Esempio punto di testa montato
 su lato inferiore solaio

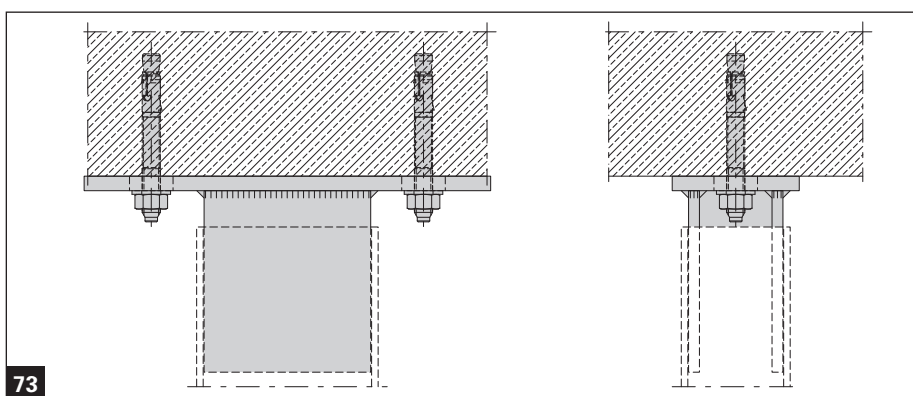

73

Beispiel Befestigung auf Betondecken-
 Stirnseite (Durchlaufträger)

Exemple fixation sur face avant
 de plafond en béton (poutre continue)

Example of fixing on front side of
 concrete slab (continuous beam)

Esempio di fissaggio su lato
 frontale solaio in cs (amovibile)

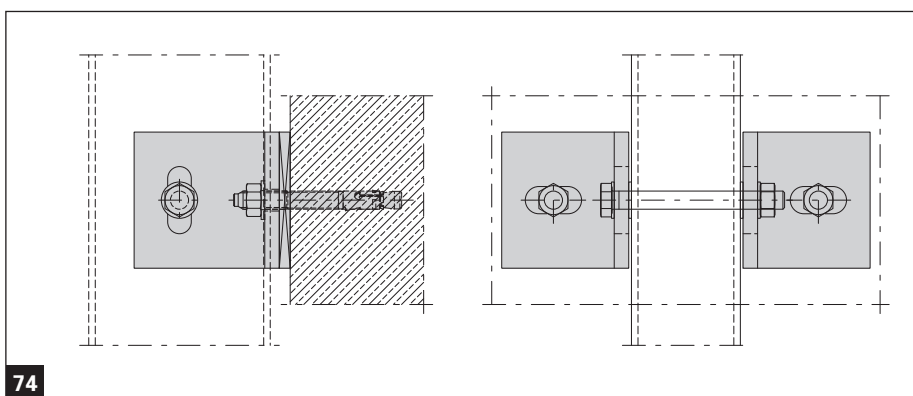

74

Beispiel Befestigung auf Betondecken-
 Stirnseite (Fix- und Lospunkt)

Exemple fixation en face avant
 de plafond en béton (point fixe et point
 non fixe)

Example of fixing on front side
 of concrete slab (fixing point and
 sliding bearing point)

Esempio di fissaggio su lato frontale
 solaio in cs (1 punto fisso e 1 mobile)

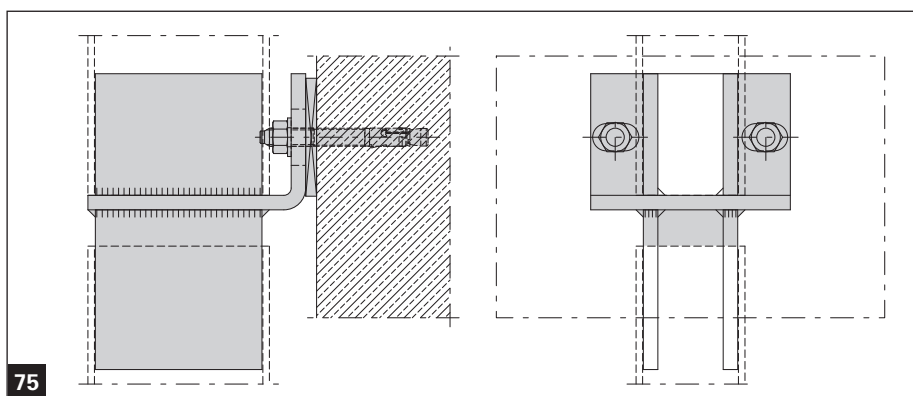

75

5. *Abdichtungsbeispiele Fusspunkte / Kopfpunkte*
 5. *Exemples d'étanchéification appuis inférieurs/ appuis supérieurs*

5. *Base point/top point sealing examples*
 5. *Esempi di impermeabilizzazione punti di base/ punti di testa*

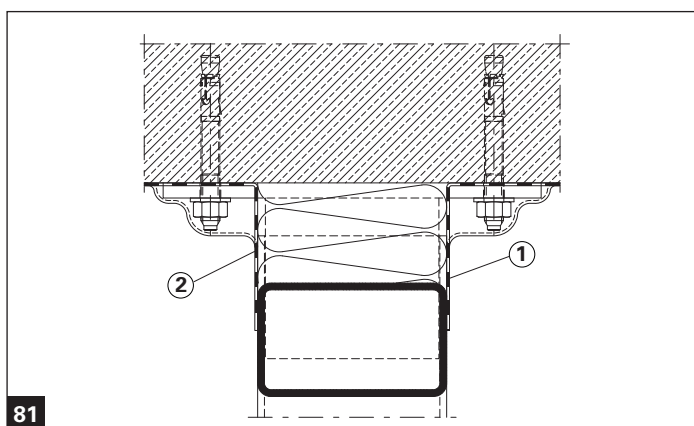
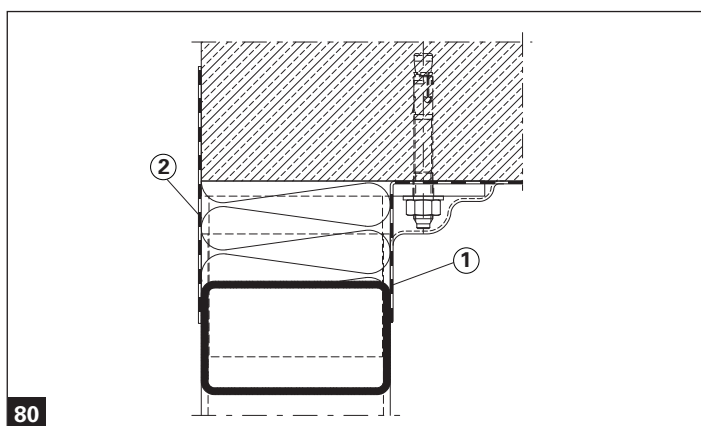
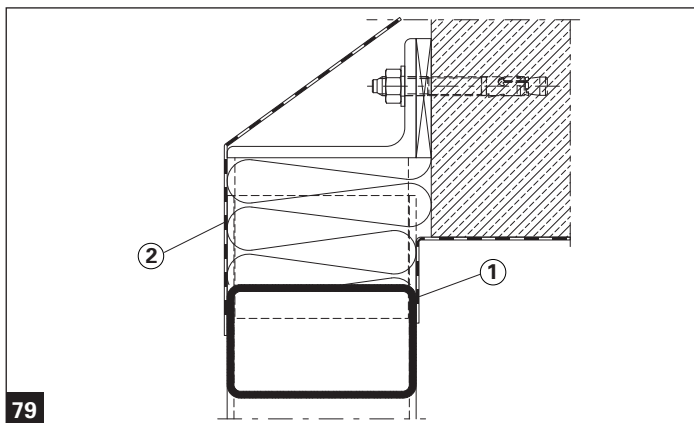
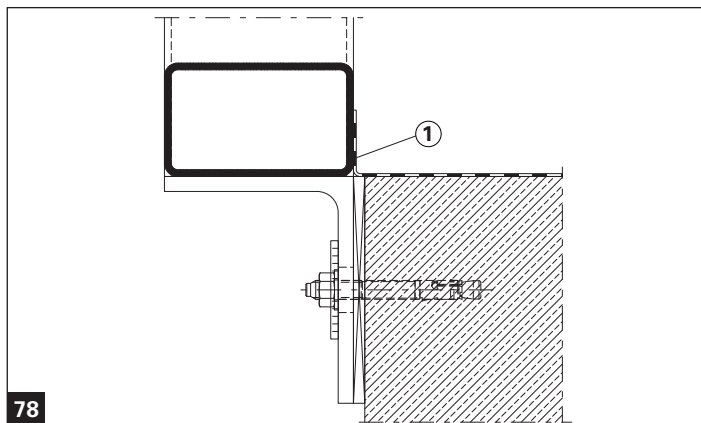
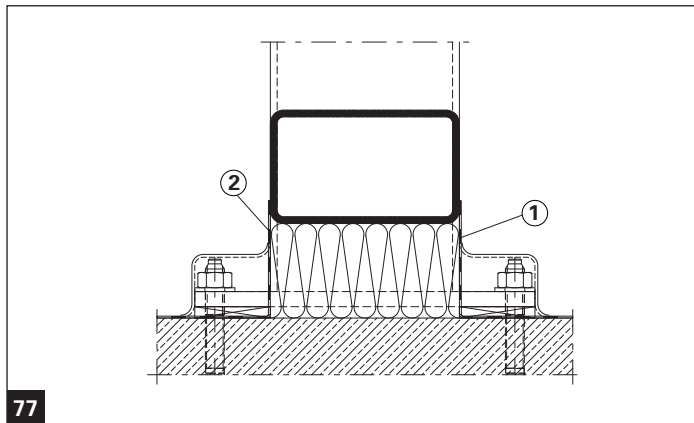
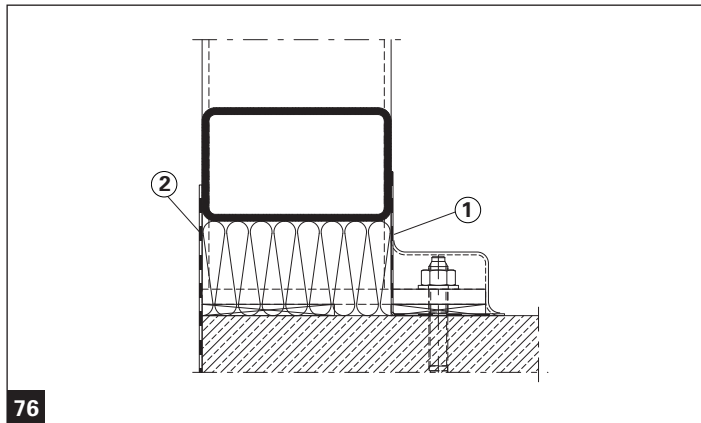

- ① Innenbereich:
Abdichtung dampfdiffusions- und luftdicht
- ② Aussenbereich:
Abdichtung dampfdiffusionsoffen, schlagregendicht

- ① Interior:
Vapour-proof and airtight seal
- ② Exterior:
Moisture-permeable, watertight seal

- ① Intérieur:
imperméable à la diffusion de vapeur et à l'air
- ② Extérieur:
perméable à la diffusion de vapeur, étanche à la pluie battante

- ① Area interna:
tenuta antidiffusione vapore e all'aria
- ② Area esterna:
tenuta permeabile al vapore, tenuta all'acqua

6. Abdichtung Tragkonstruktion

Nach der Montage der VISS Basic-Tragkonstruktion am Bau sollte der Einbau der Glaselemente grundsätzlich möglichst rasch erfolgen. Ist dies aus verschiedenen Gründen nicht möglich, so sollte die Tragkonstruktion bei schlechter Witterung mittels Planen abgedeckt werden. Dies gilt besonders bei exponierten, der Witterung ausgesetzten, Fassadenkonstruktionen.

Vor der Montage der Innendichtungen resp. vor dem Glaseinbau prüfen, ob sich allenfalls Wasser im Riegelhohlraum befindet. Falls ja, Wasser/Feuchtigkeit ausblasen resp. trocknen (Abb. 01/02).

6. Étanchéification de la construction porteuse

Les éléments de vitrage devraient toujours être montés rapidement après l'installation de la construction porteuse VISS Basic. Si cela est impossible pour différentes raisons, la construction porteuse devrait être recouverte de bâches en cas de mauvais temps. Cela est en particulier le cas pour les constructions de façade soumises aux intempéries. Contrôler avant de monter les joints intérieurs et le vitrage si de l'eau se trouve dans la cavité de la traverse. Si cela est le cas, éliminer l'eau/l'humidité par soufflage et sécher (Fig. 01/02).

6. Sealing of load-bearing structure

After installation of the VISS Basic load-bearing structure on site, the glass units must always be installed as quickly as possible. If this is not possible for various reasons, the load-bearing structure must be covered by tarpaulin in case of bad weather. This applies in particular to façade constructions that are exposed to the weather.

Before installation of the internal gaskets or before installing the glass, check whether there is water in the transom hollow space. If so, blow out or dry the water/moisture (Fig. 01/02).

6. Impermeabilizzazione struttura portante

Dopo il montaggio della struttura portante VISS Basic alla muratura dovrebbe seguire, il più presto possibile, quello degli elementi in vetro. Se questo non dovesse essere possibile, per svariati motivi, si dovrà provvedere, in caso di maltempo, a coprire la struttura portante con dei teli. Quanto detto vale in particolare per facciate esposte ai fenomeni atmosferici.

Prima di montare le guarnizioni interne o i vetri, verificare l'eventuale presenza di acqua nelle cavità del traverso. In caso affermativo soffiare via l'acqua/l'umidità o asciugarla (fig. 01/02).

Versatz

Décalage

Versatz im Kreuzpunkt
Décalage au point d'intersection

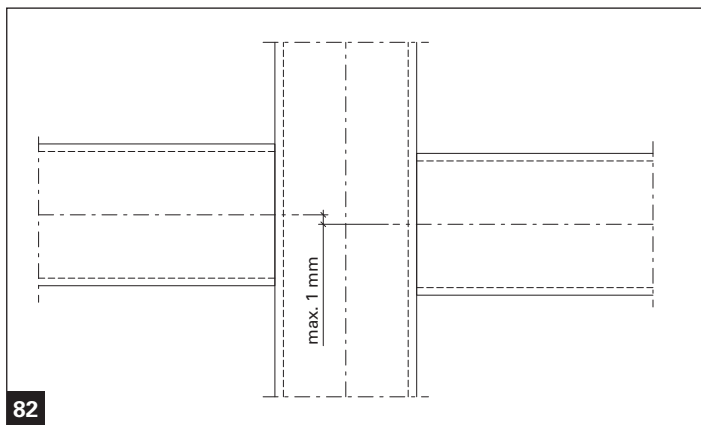

Profilübergang Kreuzpunkt
Alignement au point d'intersection

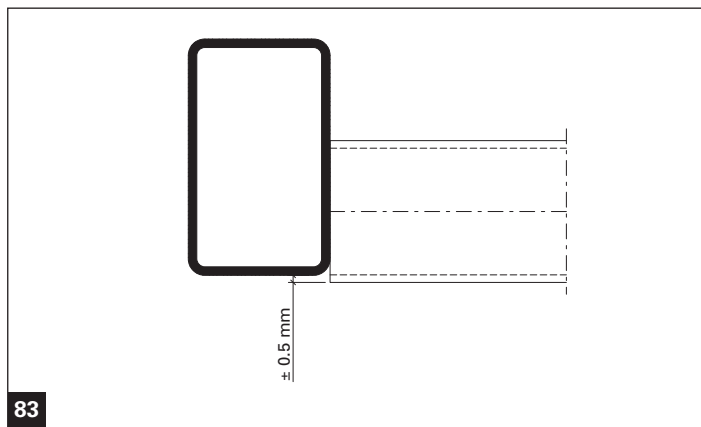

Offset

Disassamento

Offset in intersection
Disassamento in corrispondenza del punto di intersezione

Beim Versatz im Kreuzpunkt wird von der Profilachse ausgegangen. Diese darf zwischen den Riegeln links und rechts des Kreuzpunktes max. 1 mm abweichen.

Le décalage au point d'intersection se calcule à partir de l'axe du profilé. Ce dernier ne doit diverger que de 1 mm max. entre les traverses sur la gauche et la droite du point d'intersection.

The offset in the intersection is based on the profile axis. This may deviate between the transoms to the left and right of the intersection by a maximum of 1 mm.

In caso di disassamento nel punto di intersezione il riferimento è l'asse del profilo, il cui scostamento, a sinistra e a destra del punto di intersezione, non può essere maggiore di 1 mm.

Profile transfer intersection
Passaggio tra profili nel punto di intersezione

Für die Gewährleistung eines gleichmäßigen Anpressdruckes darf dieser Versatz max. $\pm 0,5$ mm betragen. Der Anpressdruck hat einen direkten Einfluss auf die Dichtigkeit der Konstruktion.

Ce décalage ne doit pas être supérieur à $\pm 0,5$ mm afin de garantir une pression d'appui régulière. La pression d'appui a une influence directe sur l'étanchéité de la construction.

To ensure an even contact pressure, this offset may be a maximum of ± 0.5 mm. The contact pressure has a direct influence on the weathertightness of the construction.

Per garantire una pressione di contatto omogenea questo disassamento non può superare il valore massimo di $\pm 0,5$ mm. La pressione di contatto influisce direttamente sull'ermeticità della struttura.

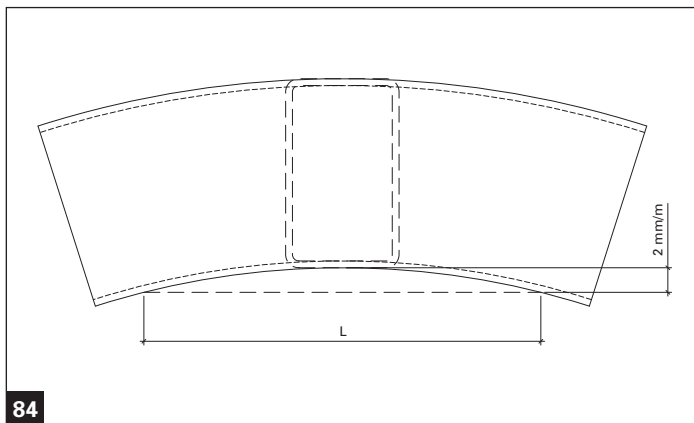

84

Geradheit der Profile:

Die Abweichung bei der Geradheit der Profile darf max. 2 mm pro Meter betragen.

Rectitude des profilés:

La divergence de rectitude des profilés ne doit pas être supérieure à 2 mm par mètre.

Straightness of the profiles:

The deviation in the straightness of the profiles must be no more than 2 mm per metre.

Rettilineità dei profili:

Lo scostamento dalla rettilineità dei profili può essere di max. 2 mm al metro.

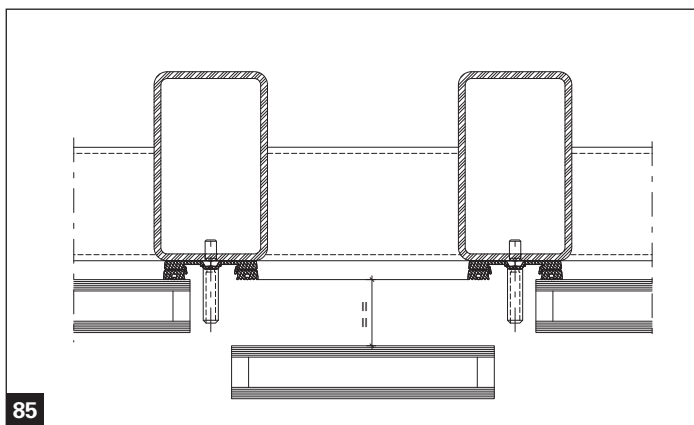

85

Planheit der Ebene:

Grundsätzlich müssen die Profile in der Ebene plan sein um einen gleichmässigen Anpressdruck zu erhalten. Ist dies nicht der Fall, entstehen zwangsläufig Spannungen in den Glasscheiben, die je nach Grösse bis zum Glasbruch führen können.

Planéité de la surface:

La surface des profilés doit toujours être plane pour qu'une pression de serrage homogène puisse être obtenue. Si cela n'est pas le cas, des tensions apparaissent inévitablement dans les vitres qui, selon leur intensité, peuvent finir par les rompre.

Flatness of the plane:

As a basic principle, the profiles must be flat in the plane in order to receive a uniform contact pressure. If this is not the case, stresses will inevitably occur in the glass panes, depending on their size, may even lead to the glass breaking.

Planarità del piano:

In linea di principio i profili devono essere planari rispetto al piano perché la pressione di contatto sia omogenea. In caso contrario si creano inevitabilmente tensioni nelle lastre di vetro che variano in funzione delle loro dimensioni e possono causarne la rottura.

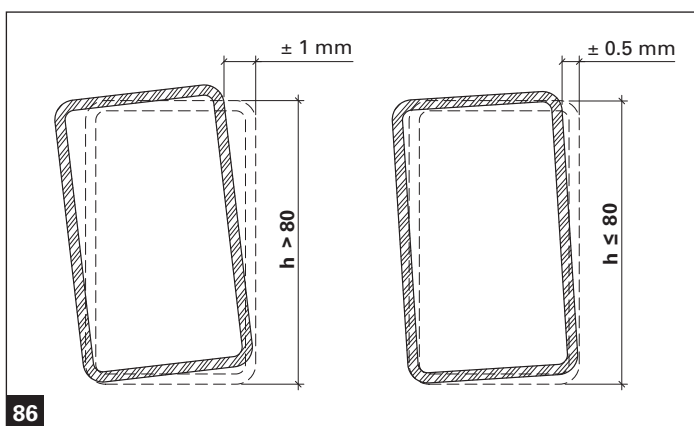

86

Verdrehung der Profile:

Die Verdrehung der Profile ist massgebend für die Gewährleistung eines gleichmässigen Anpressdruckes und folglich für die Dichtigkeit des Systems.

Torsion des profilés:

La torsion des profilés est déterminante pour garantir une pression de serrage homogène et donc l'étanchéité du système.

Torsion of the profiles:

The torsion of the profiles is decisive for ensuring a uniform contact pressure and thus ultimately the weathertightness of the system.

Torsione dei profili:

La torsione dei profili è determinante per garantire una pressione di contatto omogenea e di conseguenza l'ermeticità del sistema.

Jansen AG

Steel Systems
Industriestrasse 34
9463 Oberriet
Schweiz
jansen.com

JANSEN
Configure to Inspire