

VISS TVS (schräg)

Verarbeitung und Montage

VISS TVS (oblique)

Usinage et montage

VISS TVS (sloping)

Processing and Assembly

VISS TVS (inclinati)

Lavorazione e montaggio

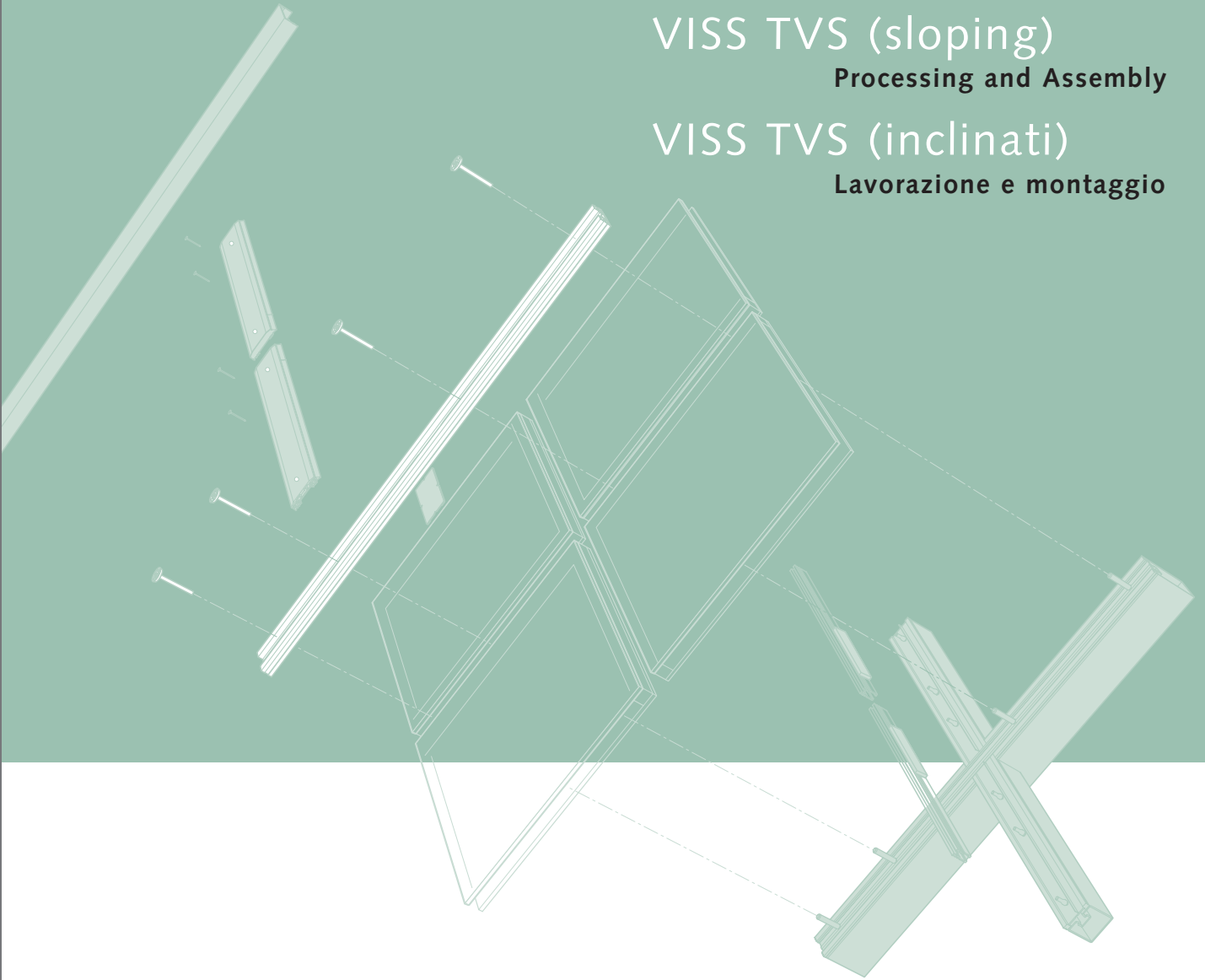

JANSEN

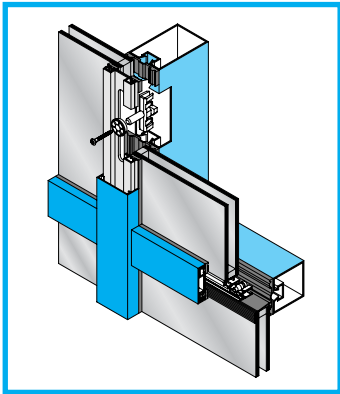

VISS TV

für Trockenverglasung vertikal / pour vitrage à sec vertical
for dry glazing, vertical / per vetratura a secco verticale

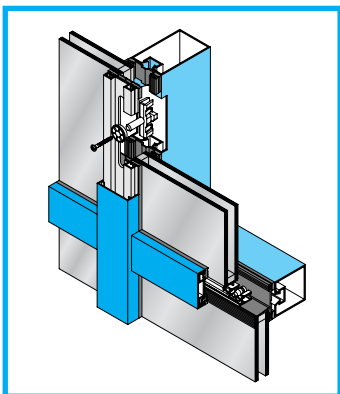

VISS TVS (vertikal)

für Trockenverglasung, Vertikal- und Schrägverglasungen
pour vitrage à sec, vitrages verticaux et obliques
for dry glazing, vertical and sloped glazing
per vetratura a secco, facciate verticale e inclinate

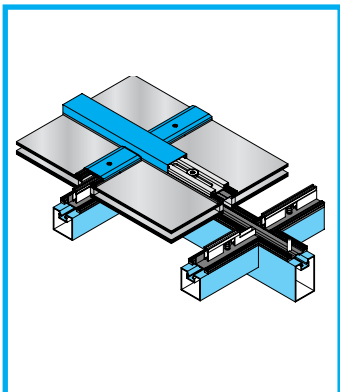

VISS TVS (schräg)

für Trockenverglasung, Schräg- und Vertikalverglasungen
pour vitrage à sec, vitrages obliques et verticaux
for dry glazing, sloped and vertical glazing
per vetratura a secco, facciate inclinate e verticale

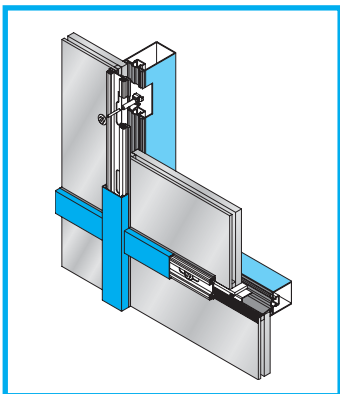

VISS Fire

für Brandschutz-Fassaden E30/60/90 / EI30/60/90
pour façades pare-flamme E30/60/90 / EI30/60/90
for fire-proof façades E30/60/90 / EI30/60/90
per facciate antincendio E30/60/90 / EI30/60/90

Tabellen Tableaux	Tables Tabella	2
Systemübersicht Aperçu du système	System overview Panoramica dei sistemi	5
Hinweise Remarques	General Information Avvertenze	6
Verarbeitung und Montage VISS TVS (schräg) Usinage et montage VISS TVS (oblique)	Processing and assembly VISS TVS (sloping) Lavorazione e montaggio VISS TVS (incline)	7
Verarbeitung und Montage Einfachverglasung Usinage et montage vitrage simple	Processing and assembly Single glazing Lavorazione e montaggio vetratura semplice	24
Artikelübersicht Vue d'ensemble des articles	Article overview Panoramica articoli	27

Alle Ausführungen dieser Dokumentation haben wir sorgfältig und nach bestem Wissen zusammengestellt. Wir können aber keine Verantwortung für die Benützung der vermittelten Vorschläge und Daten übernehmen.

Nous avons apporté le plus grand soin à l'élaboration de cette documentation. Cependant, nous déclinons toute responsabilité pour l'utilisation faite de nos propositions et de nos données.

All the information contained in this documentation is given to the best of our knowledge and ability. However, we decline all responsibility for the use made of these suggestions and data.

Abbiamo dedicato la massima cura alla preparazione della presente documentazione. Decliniamo tuttavia ogni responsabilità per l'uso delle proposte e dei dati da noi forniti.

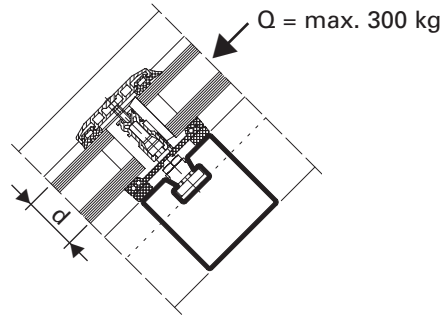

d = mm		6-10	20	21	22	23	24	25	26	27	28	29	30	31	32	33	34	35	36	37	38	39	40
	452.464	◆	◆	◆	◆	◆																	
	452.465						◆	◆	◆	◆	◆	◆	◆	◆	◆	◆	◆	◆	◆	◆	◆	◆	◆
	452.470		●	●	●	●	●	●	●														
	452.471									●	●	●	●	●	●	●	●	●	●	●	●	●	●
	452.473	●																					
	452.467		◆	◆	◆	◆	◆	◆	◆	◆	◆	◆	◆	◆	◆	◆	◆	◆	◆	◆	◆	◆	◆
	407.809	◆																					
	407.810		◆	◆	◆																		
	407.811					◆	◆	◆	◆														
	407.812									◆	◆	◆	◆										
	407.813												◆	◆	◆	◆	◆						
	407.814																		◆	◆	◆	◆	◆
	453.005		◆	◆	◆																		
	453.006					◆	◆	◆	◆														
	453.007									◆	◆	◆	◆										
	453.008												◆	◆	◆	◆	◆						
	453.009																		◆	◆	◆	◆	◆
	453.013	◆																					
	452.494	◆																					
	452.495		◆	◆	◆	◆	◆	◆	◆	◆	◆	◆	◆	◆	◆	◆	◆	◆	◆	◆	◆	◆	◆





- Anzahl entsprechend Auflagerlast Q:
75 kg = 2 x 1 Stück
150 kg = 2 x 2 Stück
300 kg = 2 x 3 Stück

- Number required depending on bearing load Q:
75 kg = 2 x 1 unit
150 kg = 2 x 2 units
300 kg = 2 x 3 units

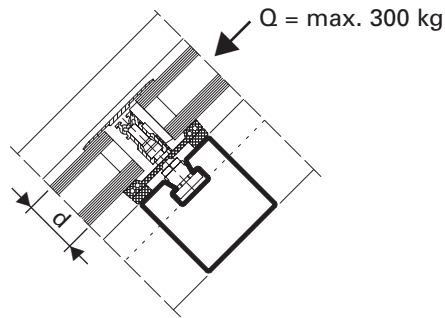
- Nombre en fonction de la charge sur 2 appuis Q:
75 kg = 2 x 1 pièce
150 kg = 2 x 2 pièces
300 kg = 2 x 3 pièces

- Numero corrispondente di peso d'appoggio Q:
75 kg = 2 x 1 pezzo
150 kg = 2 x 2 pezzi
300 kg = 2 x 3 pezzi

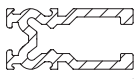

d = mm		6-10	20	21	22	23	24	25	26	27	28	29	30	31	32	33	34	35	36	37	38	39	40
	452.464	◆	◆	◆	◆	◆																	
	452.465						◆	◆	◆	◆	◆	◆	◆	◆	◆	◆	◆	◆	◆	◆	◆	◆	◆
	452.470		●	●	●	●	●	●	●	●	●												
	452.471											●	●	●	●	●	●	●	●	●	●	●	●
	452.473	●																					
	452.467		◆	◆	◆	◆	◆	◆	◆	◆	◆	◆	◆	◆	◆	◆	◆	◆	◆	◆	◆	◆	◆
	407.809	◆																					
	407.810		◆	◆	◆	◆	◆																
	407.811						◆	◆	◆	◆													
	407.812										◆	◆	◆	◆									
	407.813														◆	◆	◆	◆					
	407.814																			◆	◆	◆	◆
	453.005		◆*	◆*	◆*	◆	◆																
	453.006						◆	◆	◆	◆													
	453.007										◆	◆	◆	◆									
	453.008														◆	◆	◆	◆					
	453.009																			◆	◆	◆	◆
	453.013	◆																					

- Anzahl entsprechend Auflagerlast Q:
75 kg = 2 x 1 Stück
150 kg = 2 x 2 Stück
300 kg = 2 x 3 Stück

◆* Tragklötze müssen vorne abgeschliffen werden.

- Nombre en fonction de la charge sur 2 appuis Q:
75 kg = 2 x 1 pièce
150 kg = 2 x 2 pièces
300 kg = 2 x 3 pièces

◆* A raccourcir en face.

- Number required depending on bearing load Q:
75 kg = 2 x 1 unit
150 kg = 2 x 2 units
300 kg = 2 x 3 units

◆* The front of the glazing support must be ground.









- Numero corrispondente di peso d'appoggio Q:
75 kg = 2 x 1 pezzo
150 kg = 2 x 2 pezzi
300 kg = 2 x 3 pezzi

◆* I blocchi di supporto devono essere lisciati in testa.

Empfohlene Verarbeitungshilfen
Outils d'usinage recommandés

		VE/UV
	499.002 Kreuzschlitz-Schraubklingen Embout de tournevis cruciforme	3
	499.003 Schraubklingen SR1 Embout de tournevis SR1	3
	499.253 Dichtungsstanze für das Zuschneiden der horizontalen Innendichtungen Poinçon à joints pour la coupe des joints intérieurs horizontaux	1
	499.254 VISS-TV-Werkzeugset Jeu d'outils VISS-TV	1
	499.256 Ausklinklehre, Breite 50 mm Gabarit d'entaille, largeur 50 mm	1
	499.257 Ausklinklehre, Breite 60 mm Gararit d'entaille, largeur 60 mm	1
	499.255 Dispenser für Klebeband 455.493 499.255 Dérouleur de bande 455.493	1 1
	499.206 Abziehhebel Levier de démontage	1

Recommended assembly tools
Attrezzature consigliate

		PU/UV
	499.002 Blades for cross-recessed screws Punte a croce	3
	499.003 Blades for SR1-head screws Punte SR1	3
	499.253 Gasket punch for cutting horizontal inner gaskets Attrezzatura taglio orizzontale guarnizioni VISS	1
	499.254 VISS-TV tool kit Kit montaggio guarnizioni VISS-TV	1
	499.256 Cut-out template, width 50 mm Utensile taglio guarnizione, larghezza 50 mm	1
	499.257 Cut-out template, width 60 mm Utensile taglio guarnizione, larghezza 60 mm	1
	499.255 Dispenser for adhesive strip 455.493 499.255 Contentitore per nastro adesivo 455.493	1 1
	499.206 Stripping lever Leva smontaggio copertine	1

VISS TVS (schräg)

VISS TVS (sloping)

VISS TVS (oblique)

VISS TVS (inclinati)

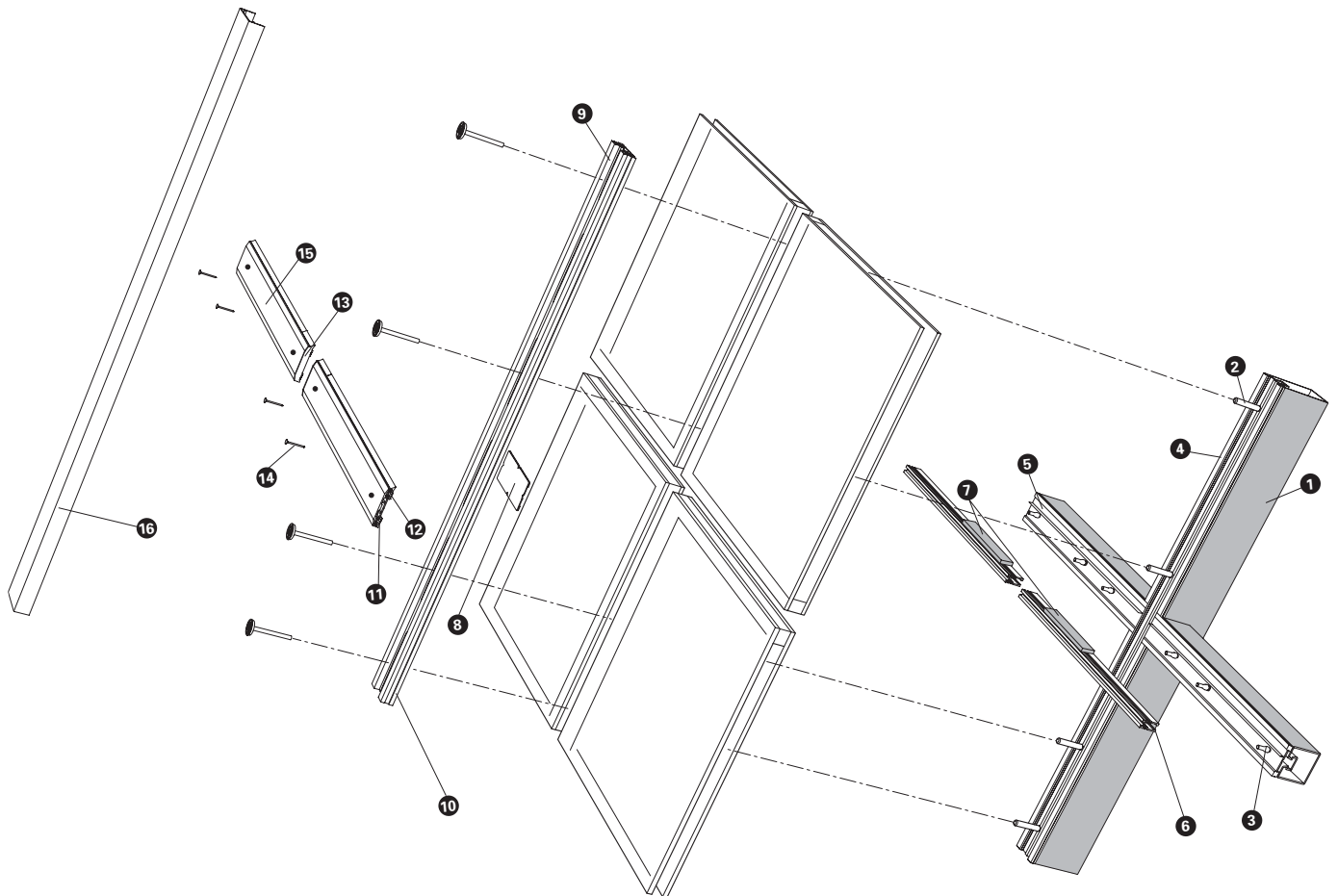

Pos. Artikel	Pos. Article	Pos. Item	Pos. Articolo
1 Tragkonstruktion	1 Construction porteuse	1 Load-bearing structure	1 Struttura portante
2 Isolationsknopf	2 Bouton d'isolation	2 Insulating stud	2 Bottone d'isolamento
3 Klemmisolationsknopf / Traganker	3 Bouton d'isolation de serrage / Boulon-support	3 Fixing-insulating stud / Supporting bolt	3 Bottone d'isolamento a incastro / Bullone di supporto vetro
4 Innendichtung vertikal	4 Joint intérieur vertical	4 Inside weatherstripping vertical	4 Guarnizione interna verticale
5 Innendichtung horizontal	5 Joint intérieur horizontal	5 Inside weatherstripping horizontal	5 Guarnizione interna orizzontale
6 Falzprofil	6 Profilé de feuillure	6 Rebate section	6 Profilo scanalato supporto vetro
7 Tragklotz	7 Cale de remplissage	7 Glazing support	7 Blocco di supporto vetro
8 Dichtplatte	8 Plaque d'étanchéité	8 Intersection sealing plate	8 Piastra di tenuta
9 Anpressprofil	9 Profilé de fixation	9 Clamping section	9 Profilo di fissaggio
10 Aussendichtung vertikal	10 Joint extérieur vertical	10 Outside weatherstripping vertical	10 Guarnizione esterna verticale
11 Aussendichtung Riegel horizontal, unten	11 Joint extérieur horizontal de traverse, inférieur	11 Outside weatherstripping horizontal, bottom	11 Guarnizione esterna traverso inferiore
12 Aussendichtung Riegel horizontal, oben	12 Joint extérieur horizontal de traverse, supérieur	12 Outside weatherstripping horizontal, top	12 Guarnizione esterna traversa superiore
13 Endstück	13 Embout	13 End piece	13 Terminale
14 Selbstbohrschraube	14 Vis autoforeuse	14 Self-cutting screw	14 Vite autofilettante
15 Anschraubprofil	15 Profilé à visser	15 Screw-on section	15 Profilo da avvitare
16 Abdeckprofil	16 Profilé de recouvrement	16 Cover section	16 Profilo di copertura

Anwendungsbereich

Domaine d'application

Scope of application

Campo d'applicazione

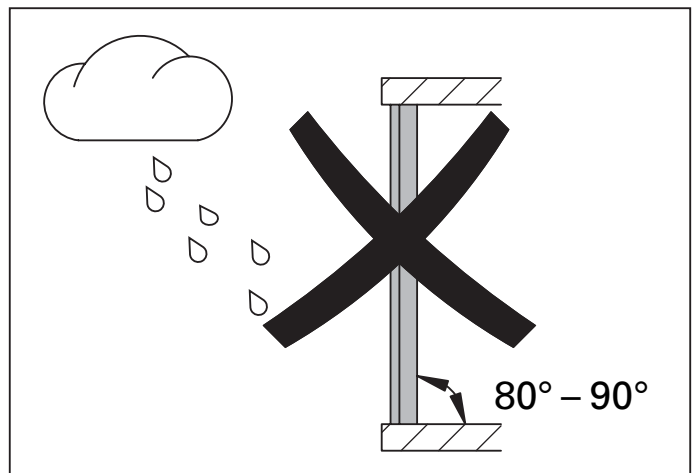
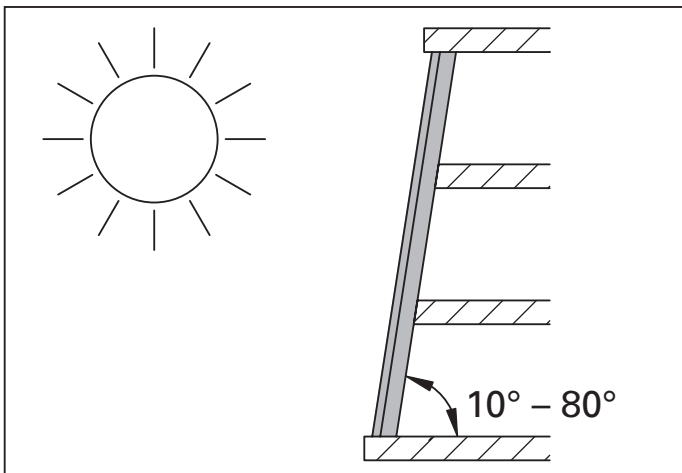
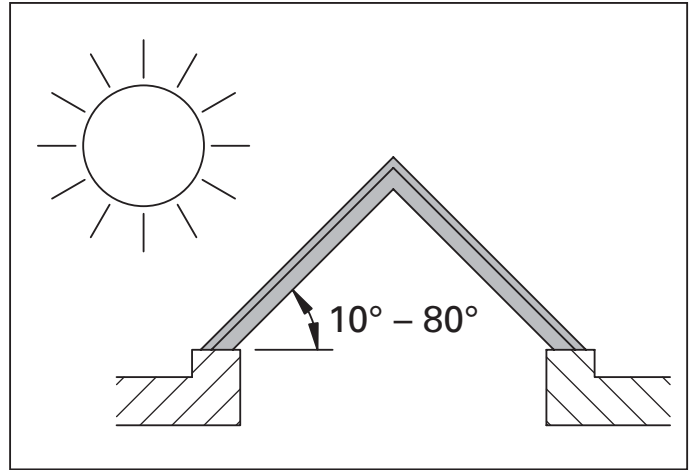
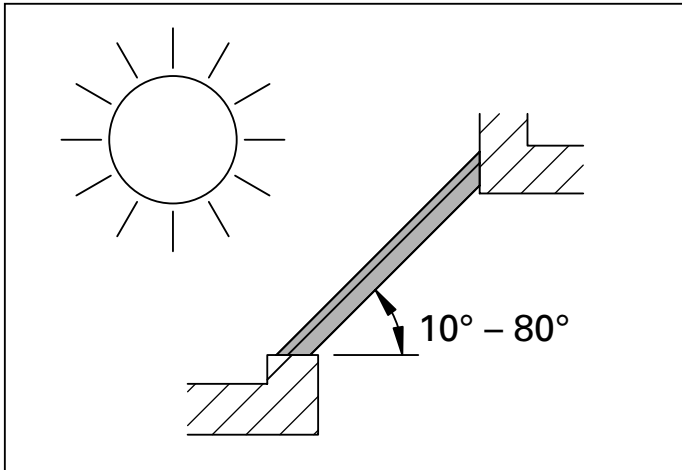

Verarbeitungs- und Montagebedingungen

Conditions de montage et d'usage

Processing and assembly conditions

Condizioni di lavorazione e montaggio

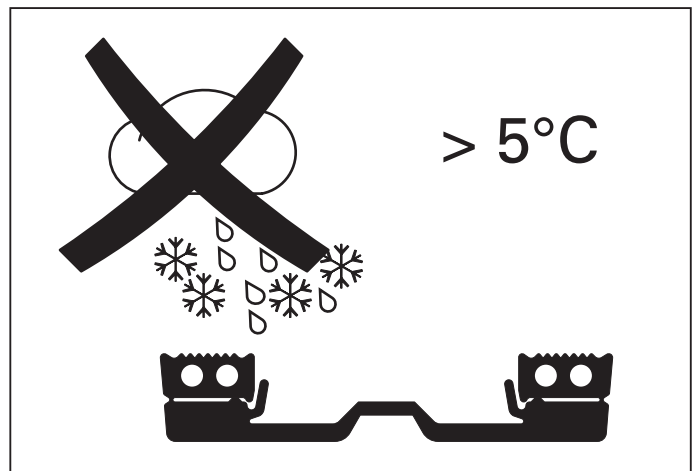
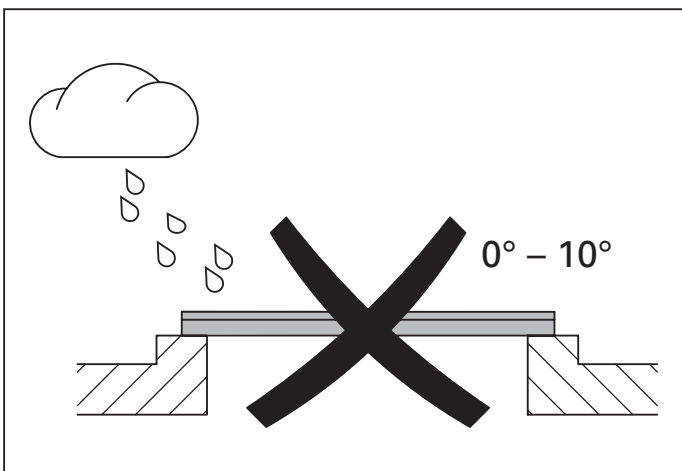

Verarbeitung und Montage VISS TVS (schräg)
Usinage et montage VISS TVS (oblique)

Processing and assembly VISS TVS (sloping)
Lavorazione e montaggio VISS TVS (inclinata)

1. Anordnung und Einsetzen der Isolationsknöpfe im Sparrenbereich

1. Positioning and inserting of insulating studs in the vicinity of rafters

1. Disposition et pose des boutons d'isolation dans la zone des chevrons

1. Disposizione e applicazione dei bottoni d'isolamento nella zona dei travetti

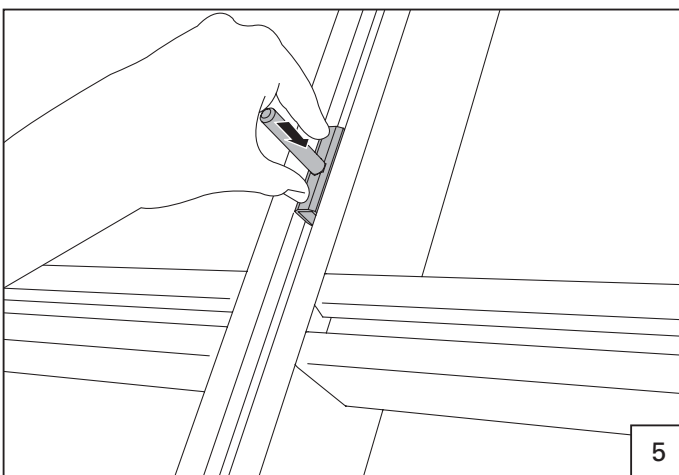
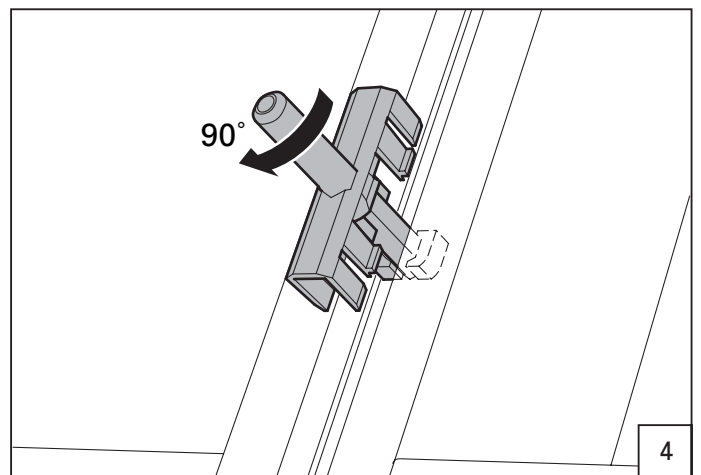
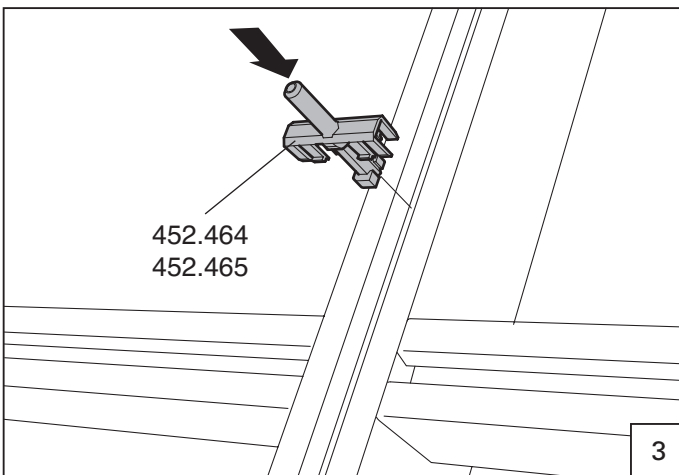
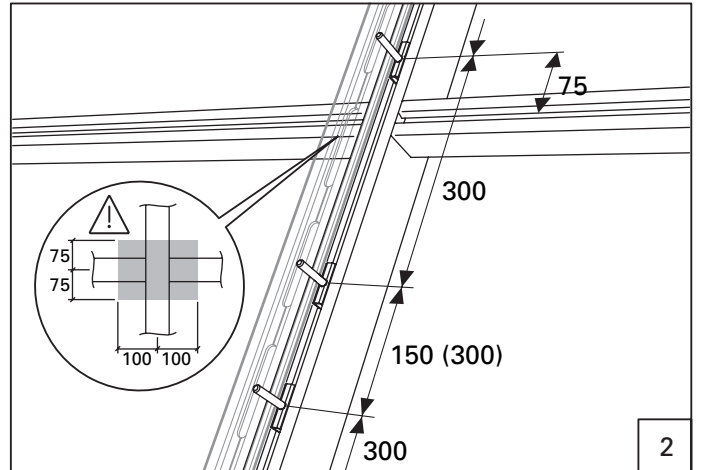
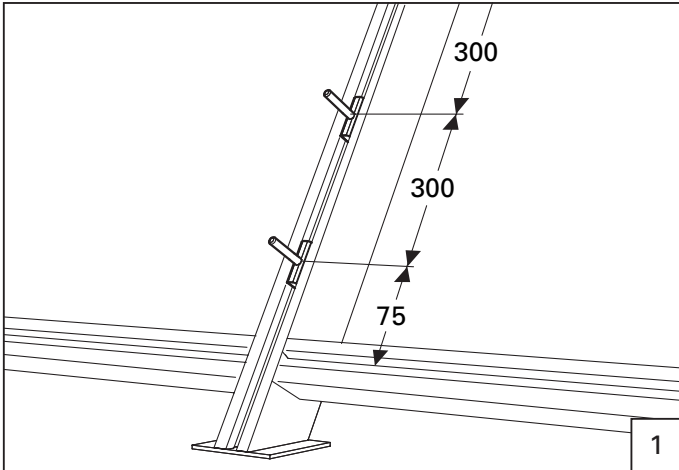

Verarbeitung und Montage VISS TVS (schräg)
Usinage et montage VISS TVS (oblique)

Processing and assembly VISS TVS (sloping)
Lavorazione e montaggio VISS TVS (inclinata)

2. Anordnung und Einsetzen der Klemmisolationsknöpfe und Traganker im Riegelbereich

2. Disposition et pose des des boutons d'isolation de serrage et des boulons-soutiens dans la zone de la traverse

α°	c	α°	c	α°	c	α°	c
10	0,17	30	0,5	60	0,87	80	0,98
20	0,34	40	0,64	70	0,94	90	1,00

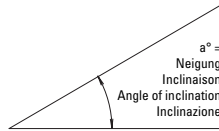

Beispiel / Exemple / Example / Esempio:

- $\alpha^\circ = 40^\circ$
- $G = 110 \text{ kg (1.1 kN)}$ Gewicht Glasscheibe / poids de la vitre / weight of glass pane / peso del vetro
- $Q = c \times G = 0.64 \times 110 \text{ kg} = 70 \text{ kg (0.70 kN)}$
- 1 Traganker pro Tragklotz (total 2 Stk. pro Glasscheibe)
1 boulon-support par cale (total 2 pcs par vitre)
1 supporting bolt per support (total 2 bolts per glass pane)
1 bullone per supporto vetro (2 bulloni per vetro)

2. Positioning and inserting fixing-insulating studs and supporting bolts in the transom area

2. Disposizione e applicazione dei bottoni d'isolamento ad incastro e dei bulloni di supporto nella zona dei traversi

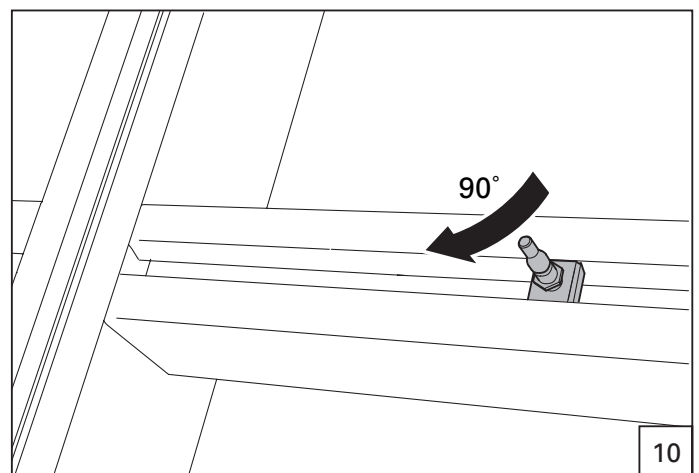
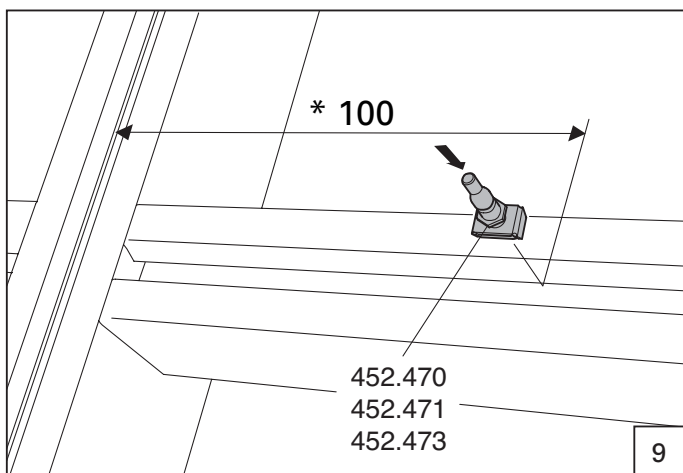
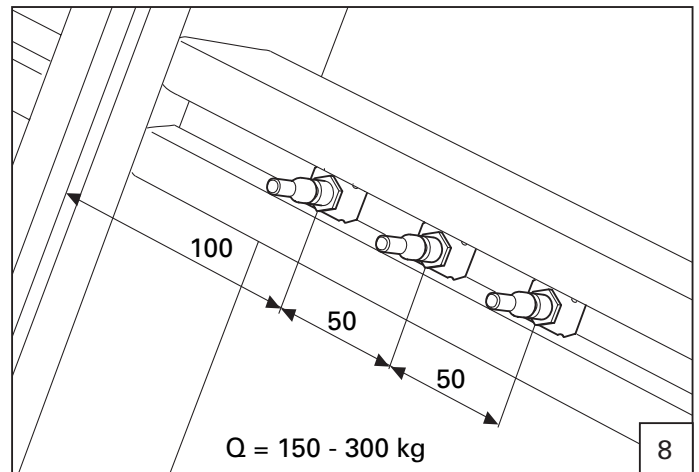
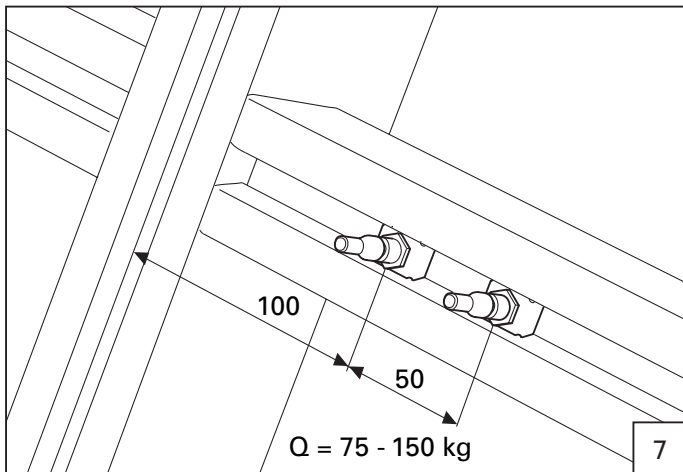
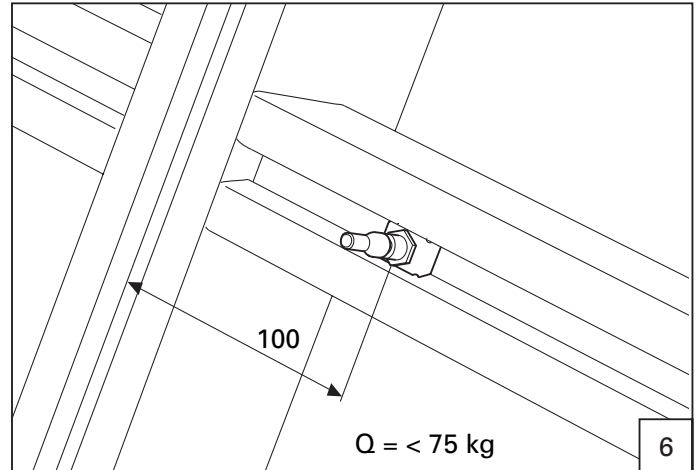

- * Position der Glasauflagen: nach SZFF-Norm 4204, bzw. gemäss Vorschrift der Glashersteller anordnen.
- * Position des supports de verre: selon la norme CSFF 4204, respectivement les prescriptions du fabricant de verre.

- * Position the glazing supports: arrange them according to SZFF 4204 or as instructed by the glass manufacturer.
- * Posizione supporto vetri: secondo la norma CSFF 4204, rispettivamente posizionare secondo le prescrizioni del fabbricante del vetro.

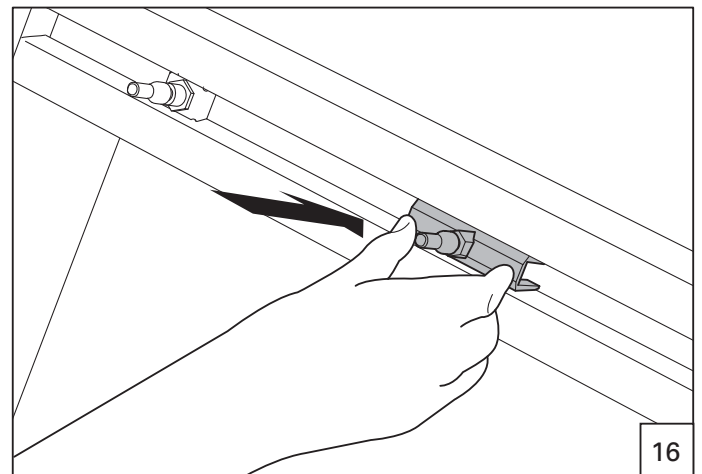
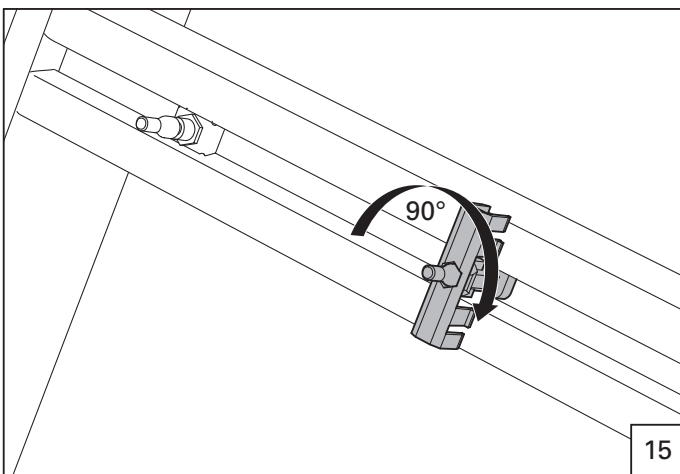
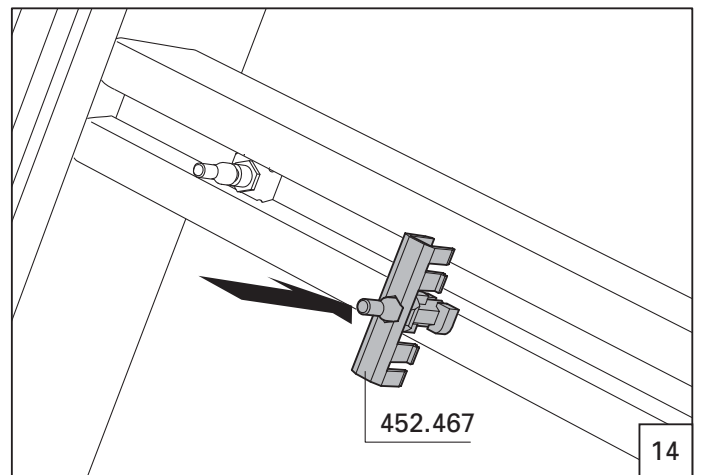
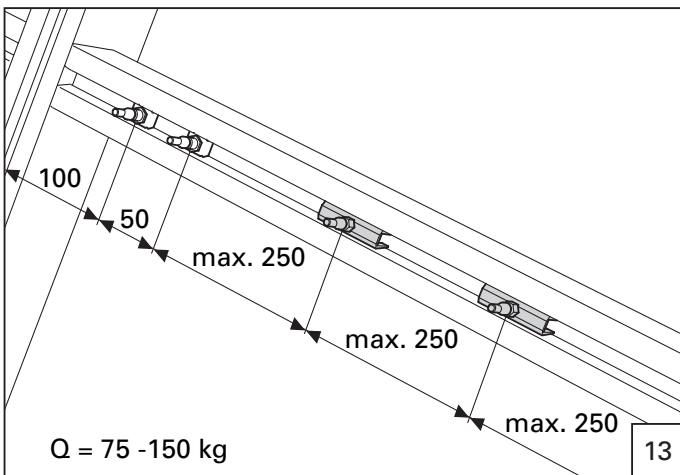
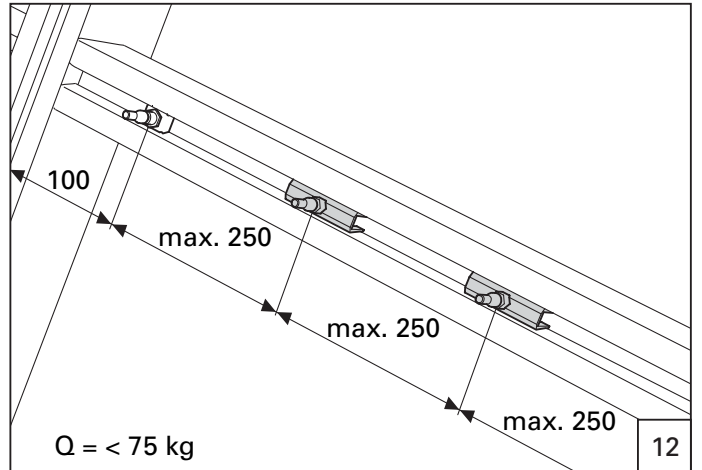
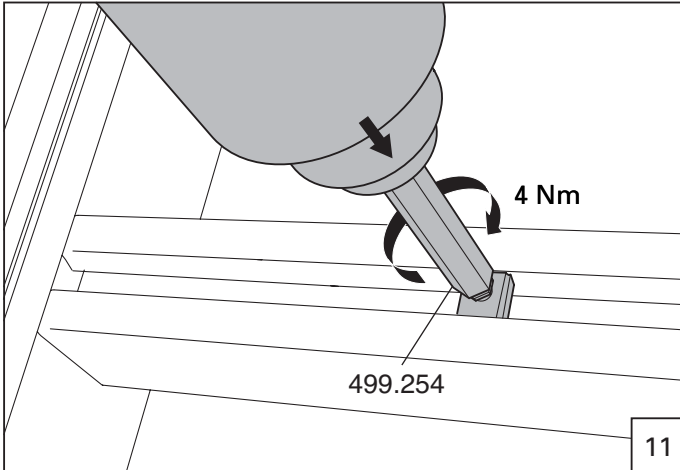

3. Einsatz der Innendichtungen

3. Mise des joints intérieurs



Lagerung

Dichtungen müssen vor Sonne, Schmutz und anderen Umwelteinflüssen geschützt werden (in Verpackungseinheit an einem kühlen Ort aufbewahren).



Stockage

Les joints doivent être protégés du soleil, de la saleté et de toute autre influence de l'environnement (les conserver dans l'emballage dans un endroit frais).



Bearing application

Weatherstrippings must be protected from sunlight, dirt and other effects of the environment (store inside the packaging unit in a cool place).



Stoccaggio materiali

Le guarnizioni devono essere protetti dal sole, sporcizia e altri influssi ambientali (magazzinare in un luogo fresco nel loro proprio imballaggio)

3.1. Einsetzen der vertikalen Dichtung
3.1. Mise en place du joint vertical

3.1. Inserting the vertical weatherstrip
3.1. Inserimento della guarnizione verticale

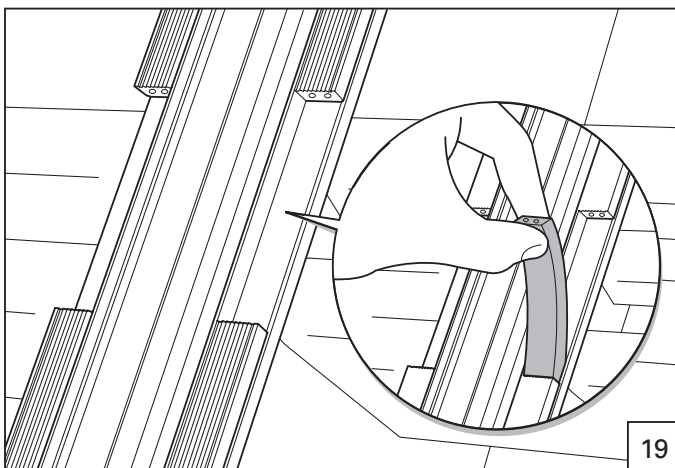
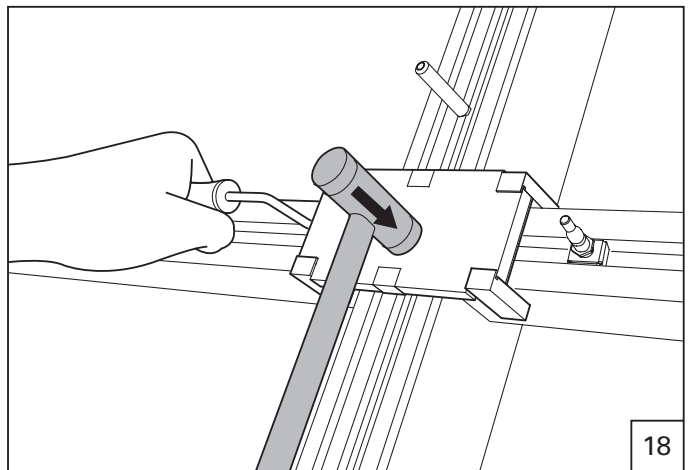
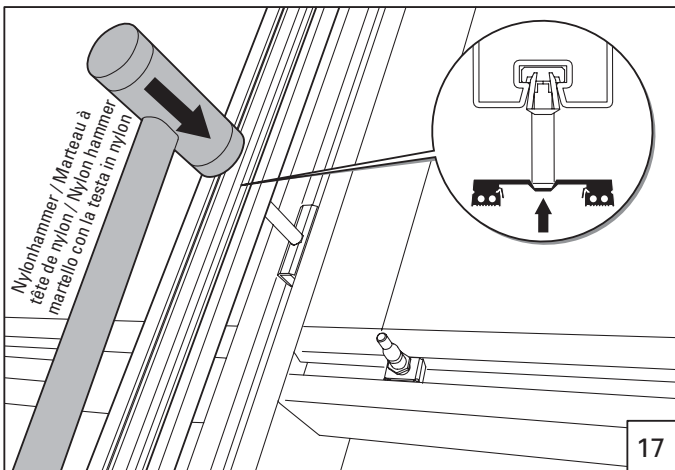

Verarbeitung und Montage VISS TVS (schräg)
Usinage et montage VISS TVS (oblique)

Processing and assembly VISS TVS (sloping)
Lavorazione e montaggio VISS TVS (inclinata)

3.2. Auslinklehre, Kreuz- und Endpunkte
 3.2. Gabarit de découpe, points croisée et points T

3.2. Cut-out template, intersection and end points
 3.2. Dima intaglio, punti di incrocio e punti a T

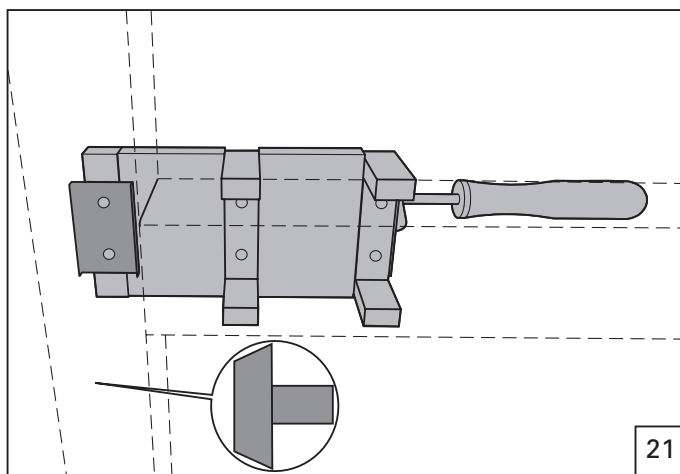
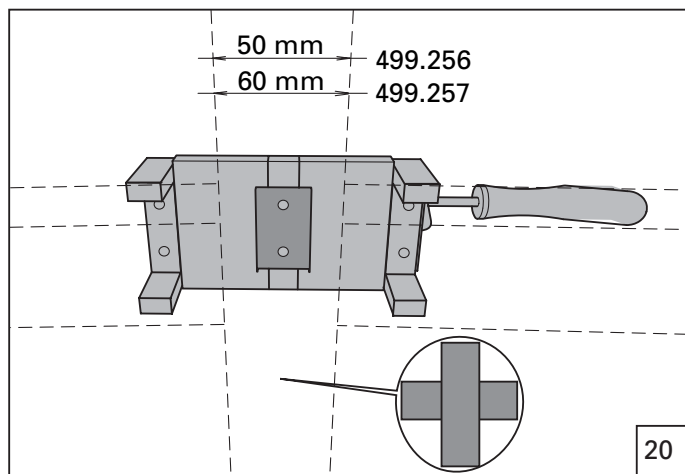

3.3. Zuschnitt der horizontalen Dichtung
 3.3. Découpe joint horizontal

3.3. Cutting horizontal weatherstrip
 3.3. Taglio della guarnizione orizzontale

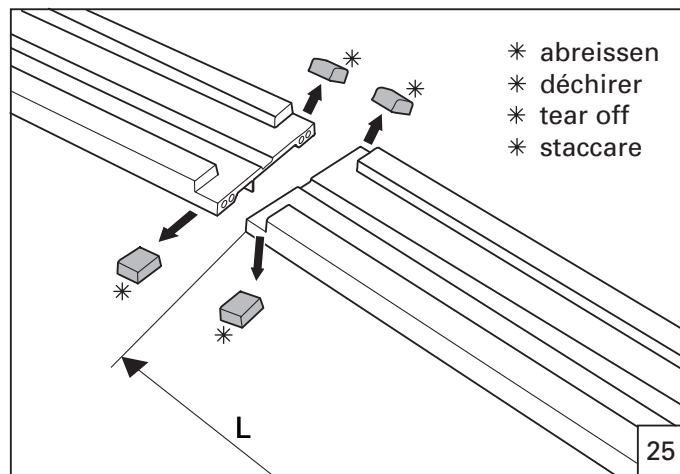
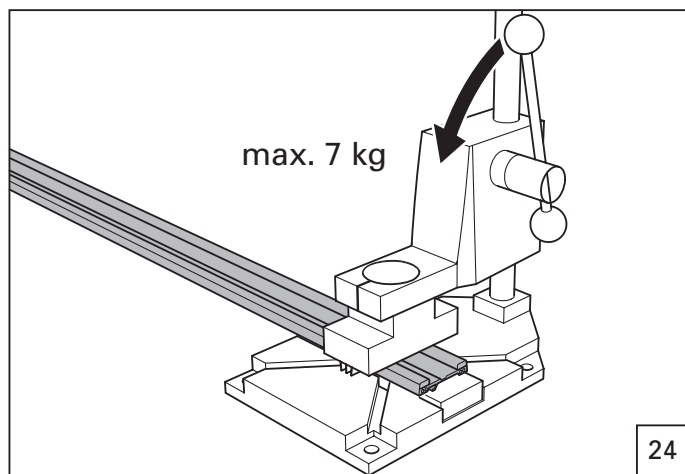
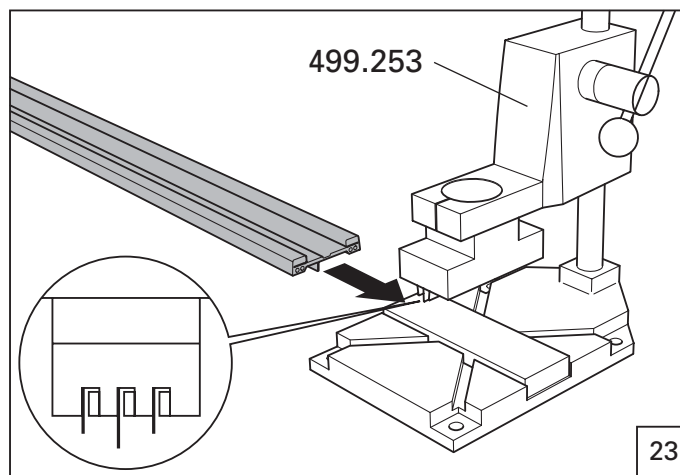
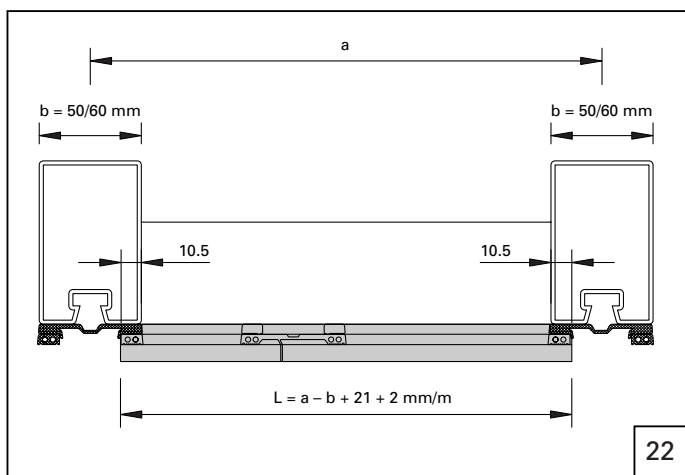

- * abreißen
- * déchirer
- * tear off
- * staccare

Verarbeitung und Montage VISS TVS (schräg)
Usinage et montage VISS TVS (oblique)

Processing and assembly VISS TVS (sloping)
Lavorazione e montaggio VISS TVS (inclinata)

3.4. Einsetzen der horizontalen Dichtung
 3.4. Mise en place du joint horizontal

3.4. Inserting the horizontal weatherstrip
 3.4. Inserimento della guarnizione orizzontale

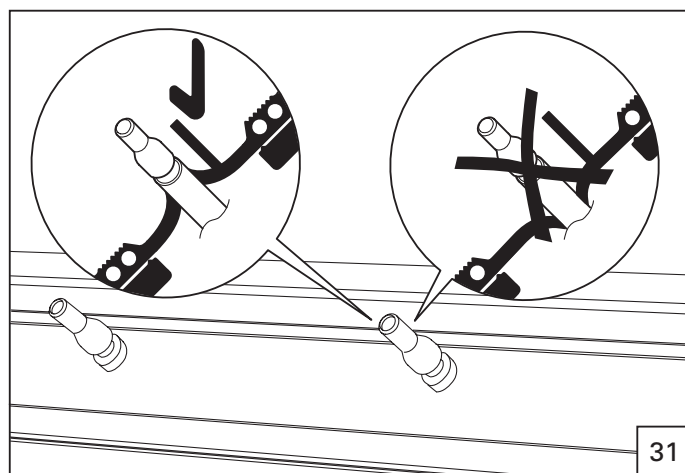
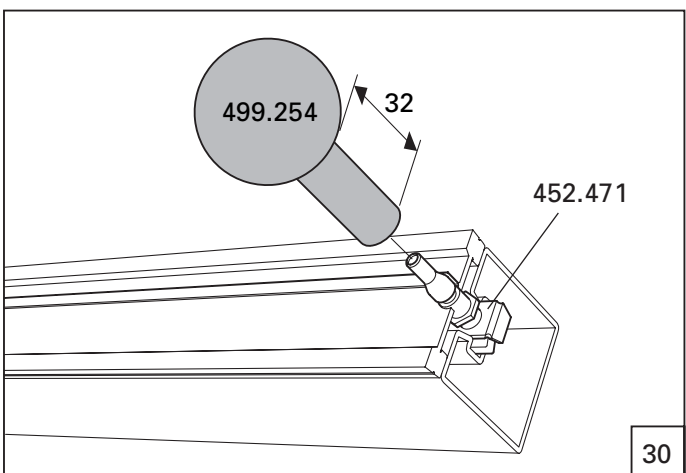
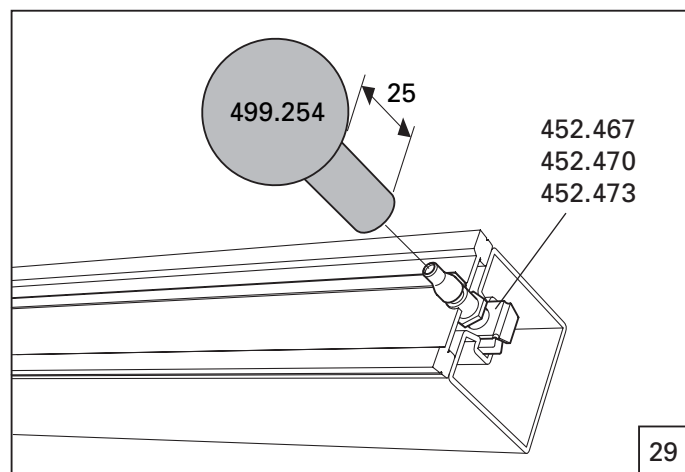
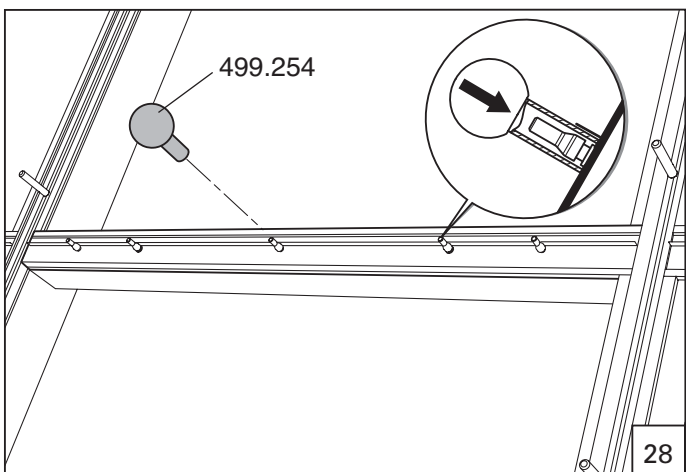
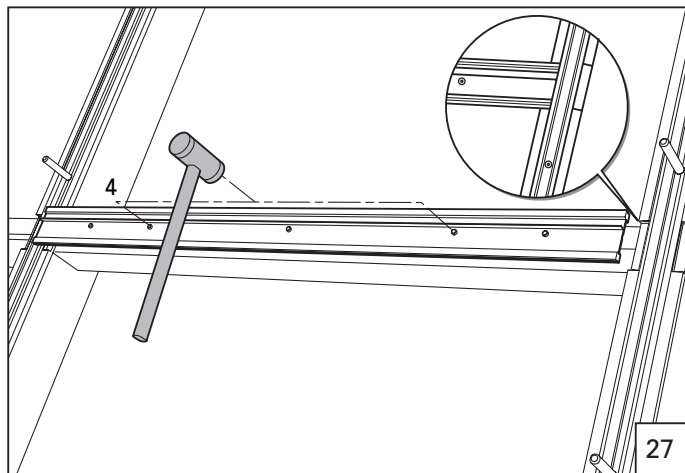
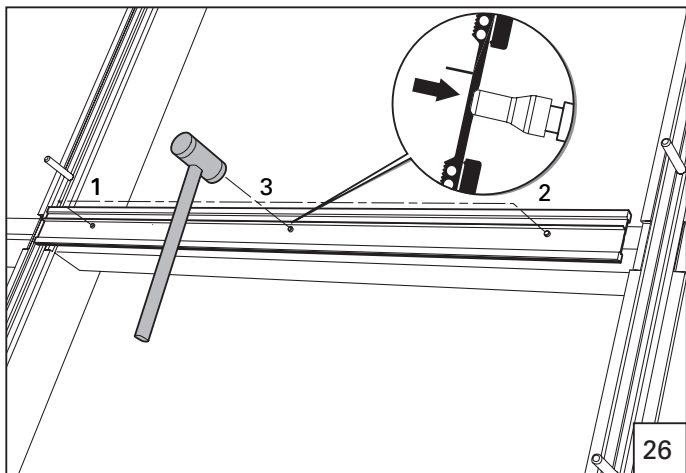

4. Abdichten der Innendichtungen

4. Etanchement des joints intérieurs

4. Sealing inside weatherstripping

4. Come rendere ermetiche le guarnizioni interne

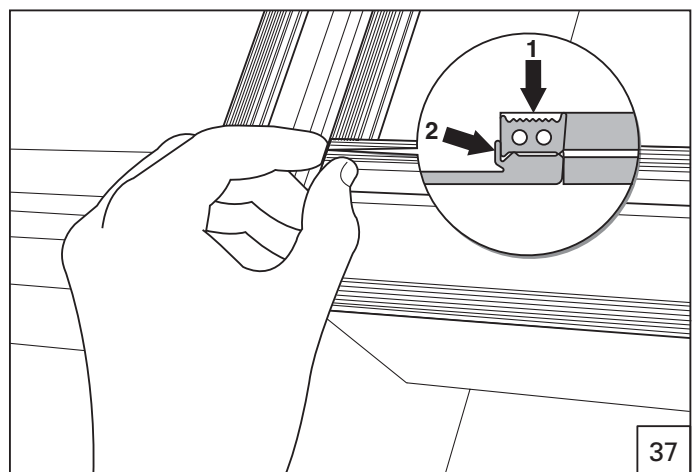
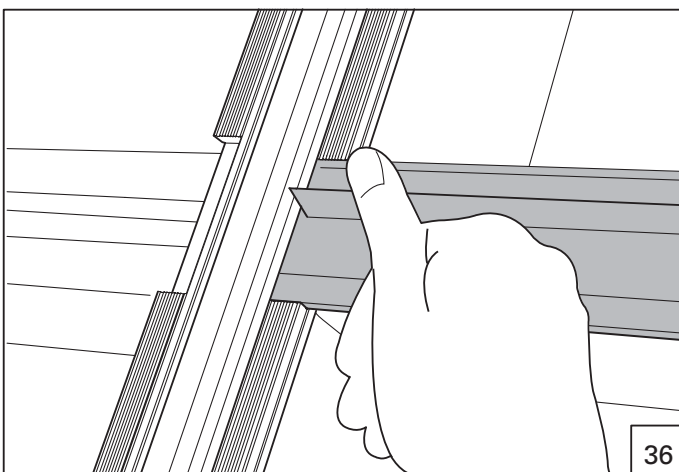
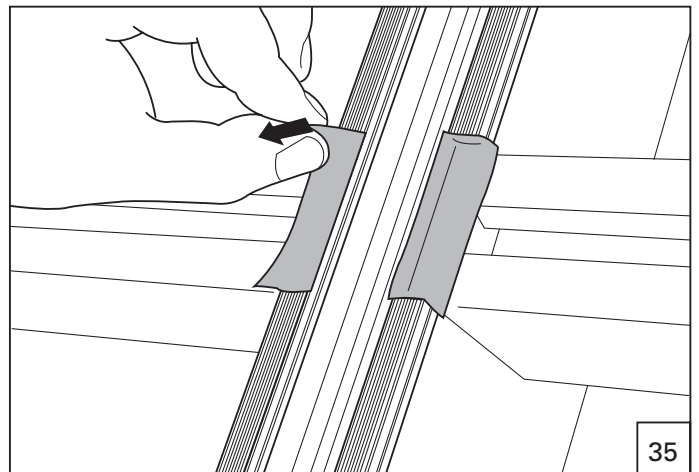
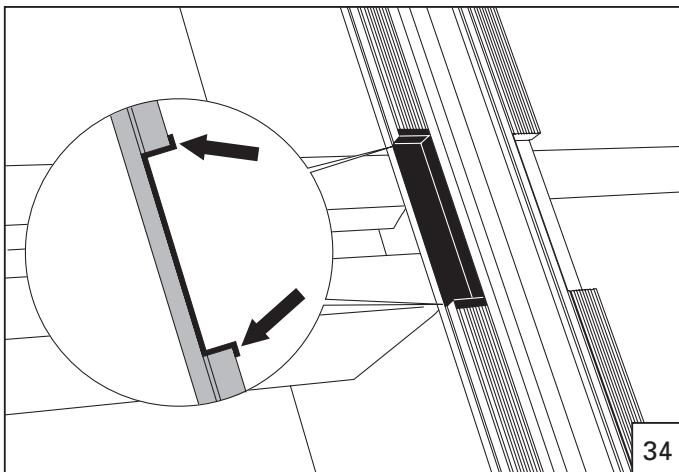
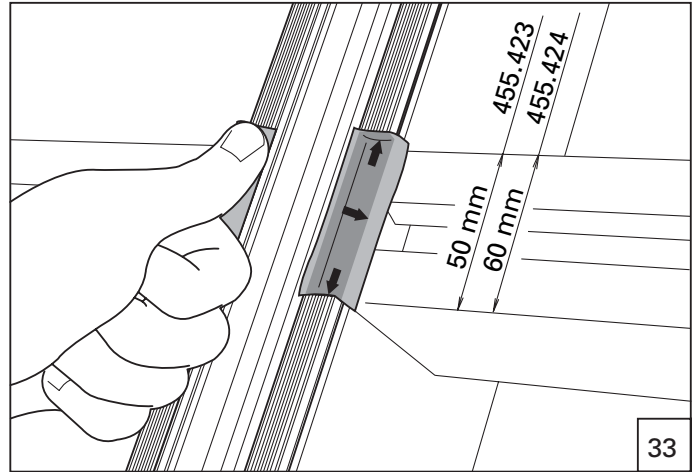
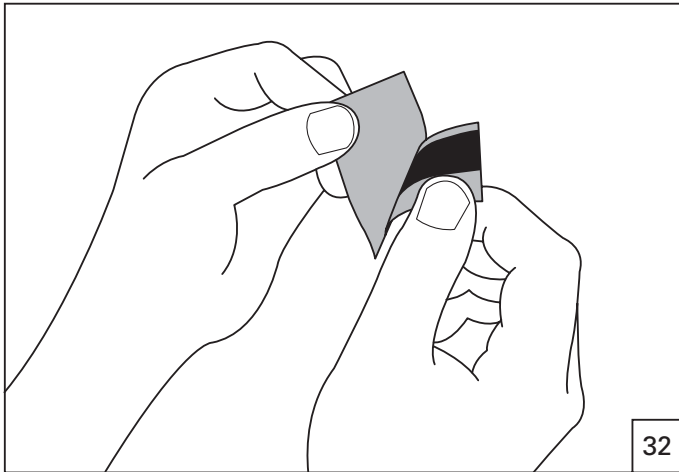

5. Montage Falzprofil / Glasauflage

5. Montage du profilé de feuillure / support de verre

5. Assembly the rebate section / glazing support

5. Montaggio profilo scanalato / supporto vetro

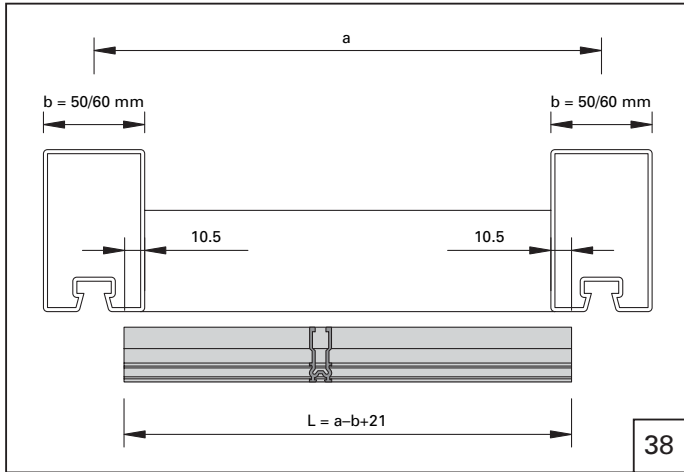

38

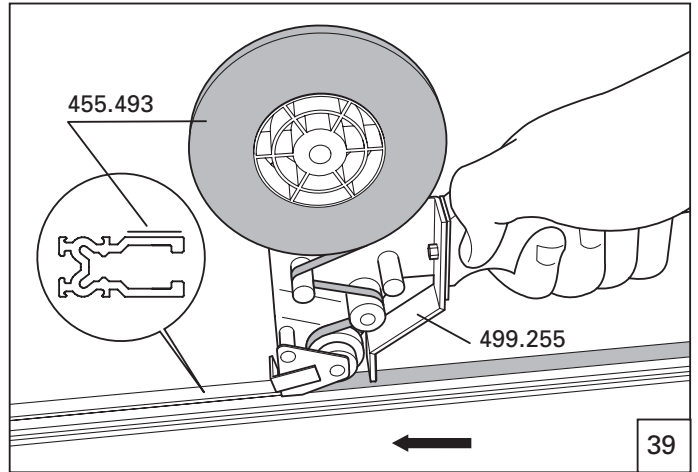

39

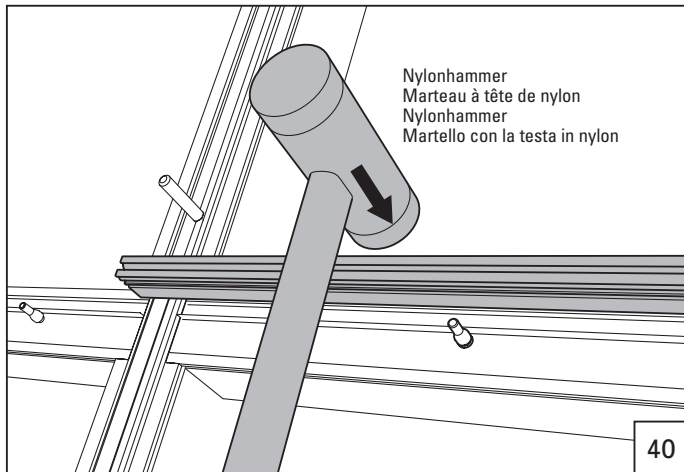

40

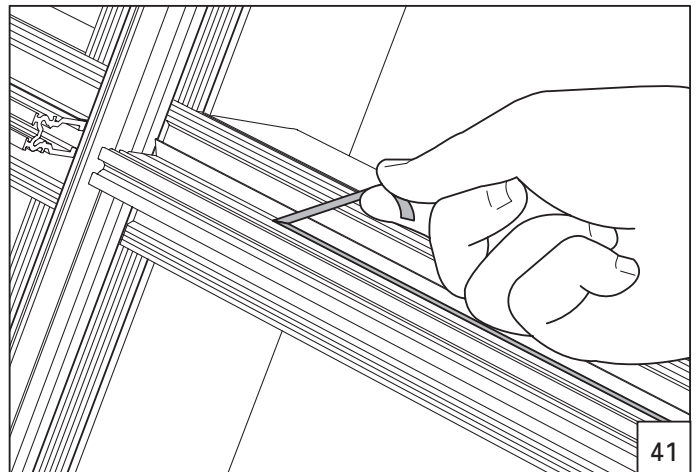

41

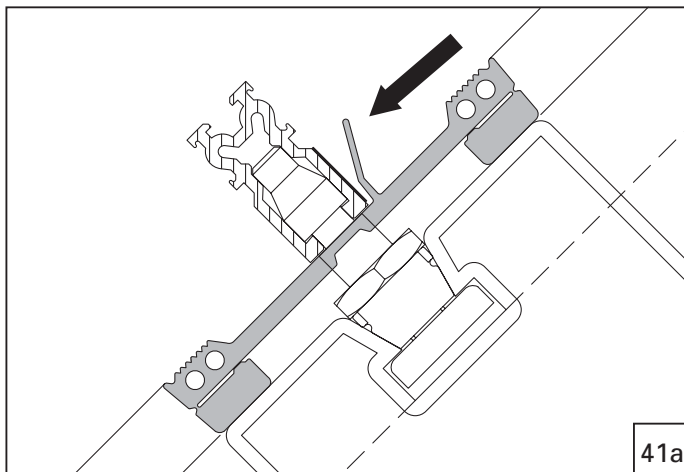

41a

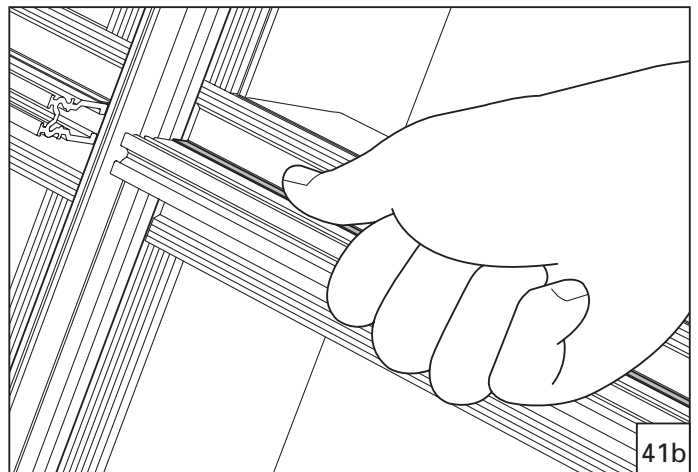

41b

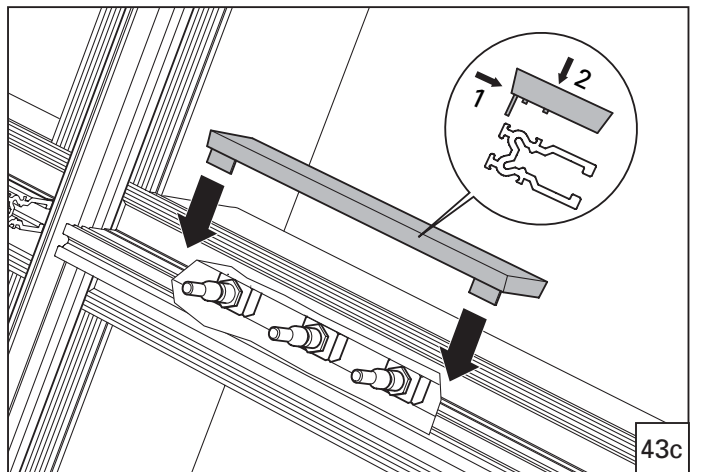
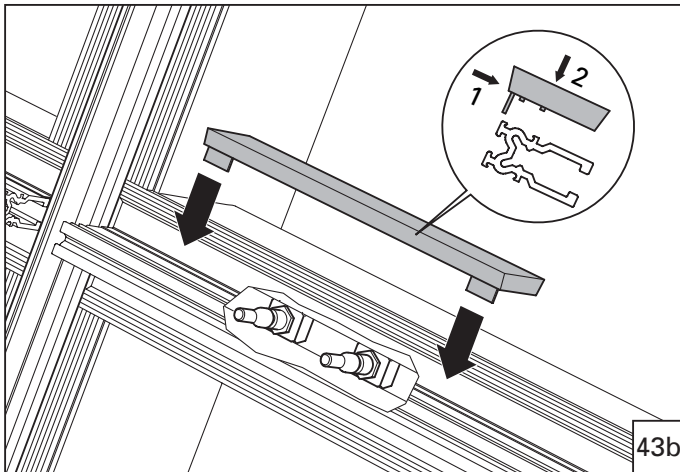
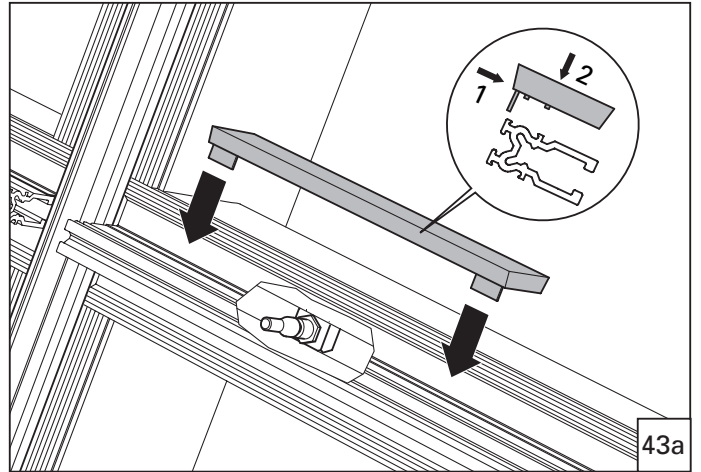
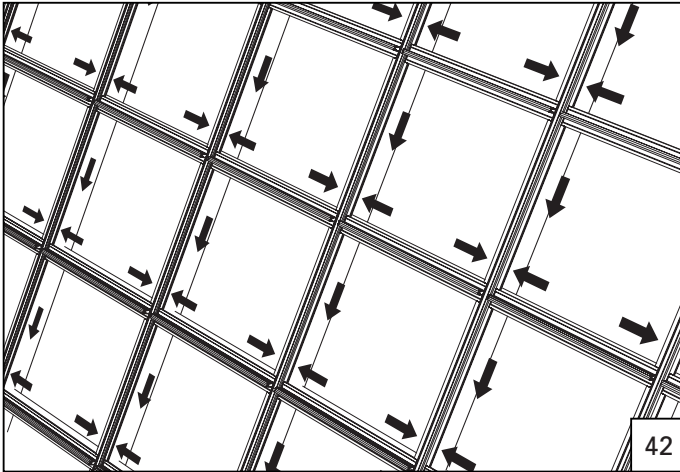

6. Füllelemente

6. Eléments de remplissage

6. Infill elements

6. Elementi di riempimento (vetro o pannello)

6.1. Abmessungen
 6.1. Mesures

6.1. Dimensions
 6.1. Misure

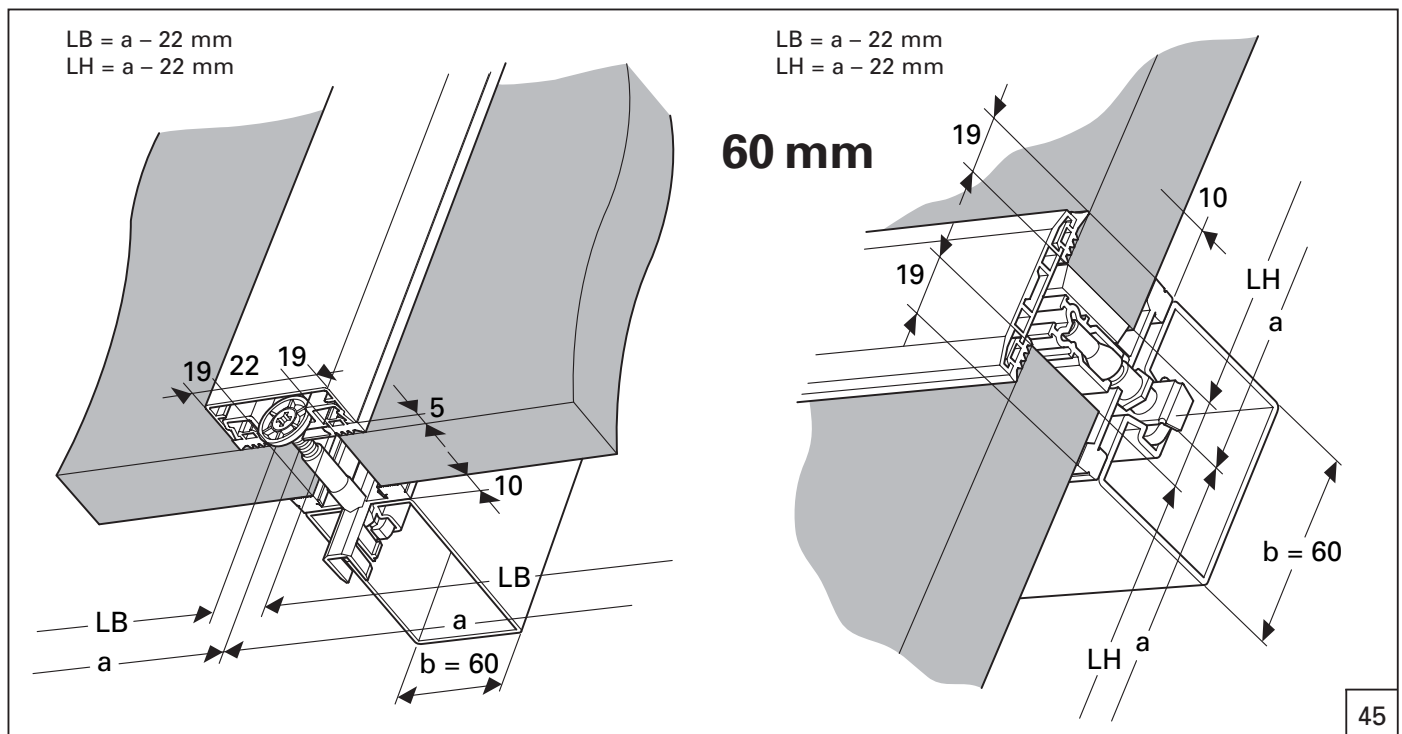
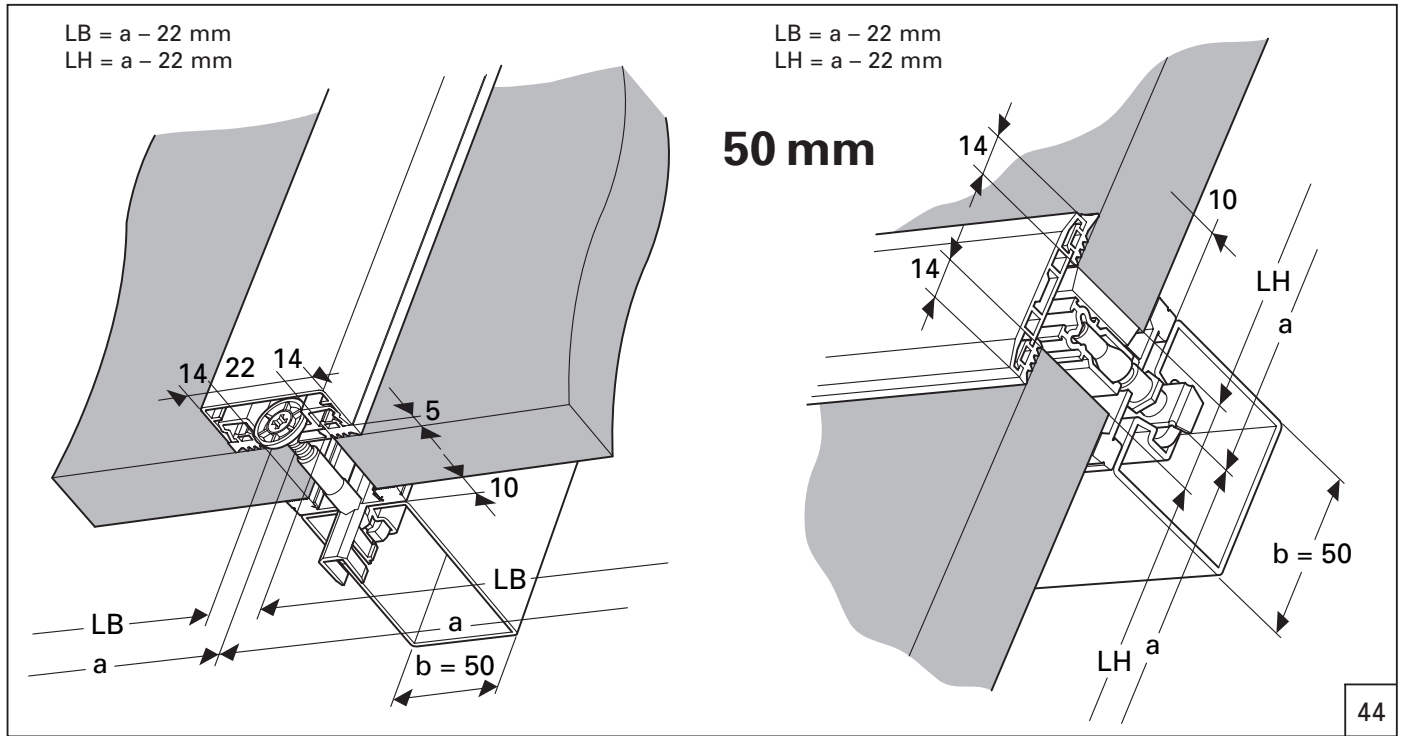

Verarbeitung und Montage VISS TVS (schräg)
Usinage et montage VISS TVS (oblique)

Processing and assembly VISS TVS (sloping)
Lavorazione e montaggio VISS TVS (inclinata)

6.2. Einsatz der Füllelemente
6.2. Montage des éléments de remplissage

6.2. Inserting infill elements
6.2. Montaggio degli elementi di riempimento

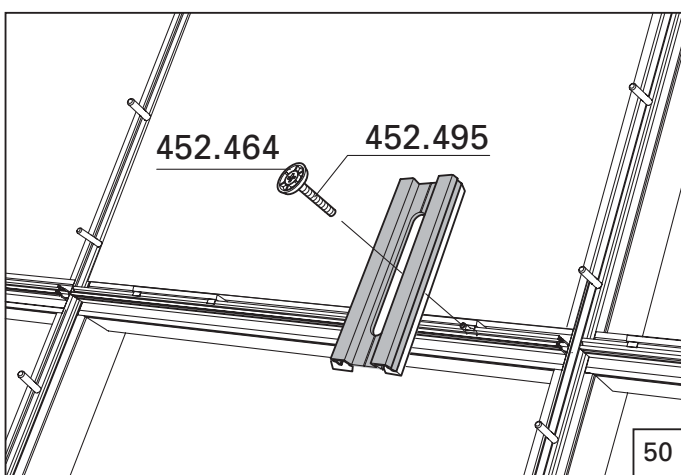
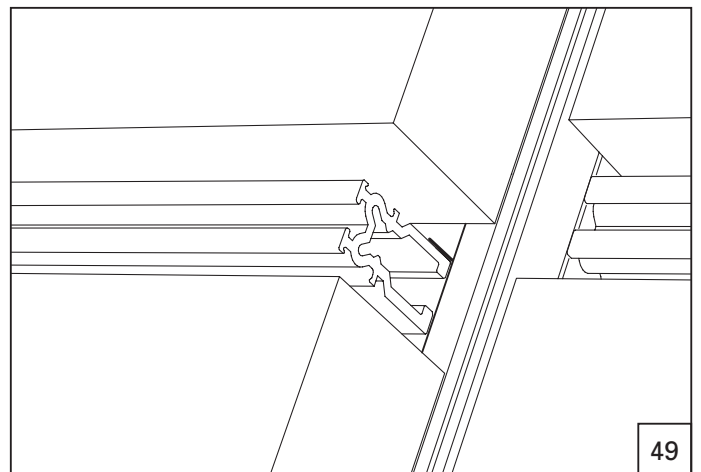
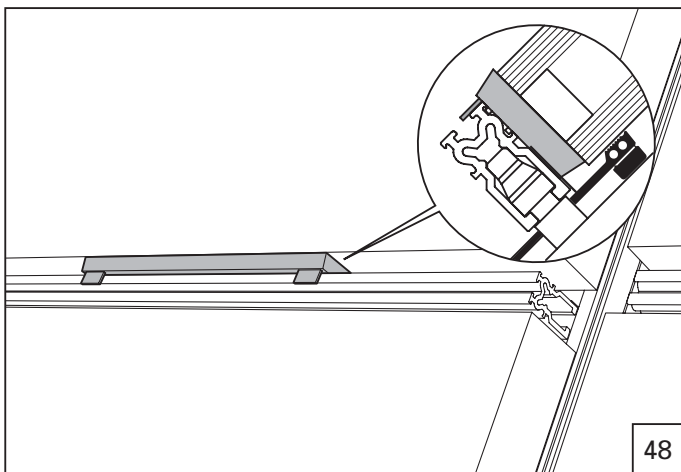
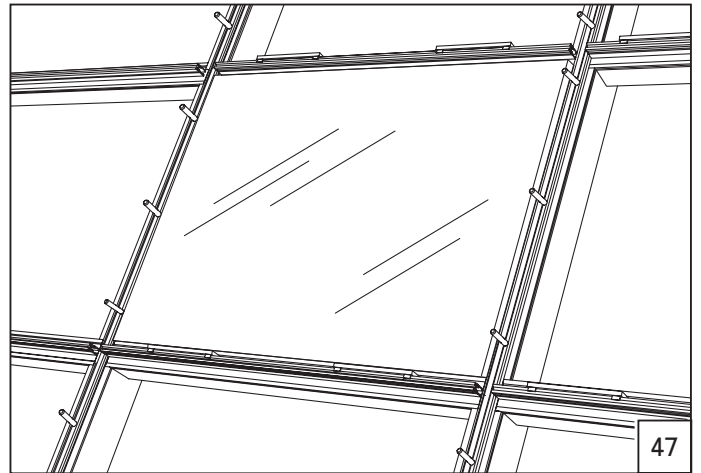
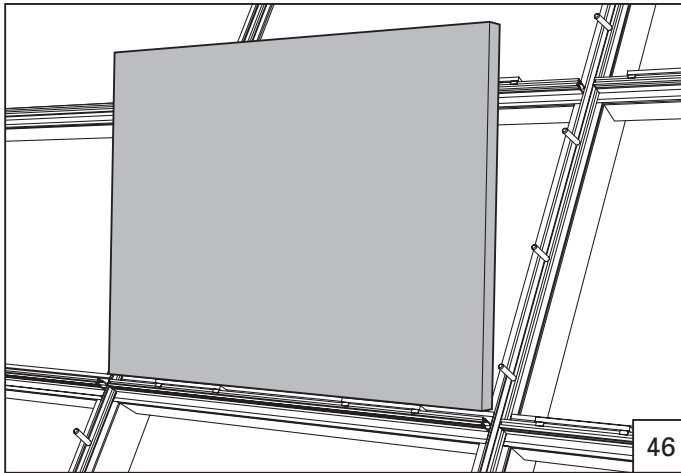

7. Zuschnitt / Einbau Dichtungen
7. Découpe / Montage des joints

7. Cutting / Installing weatherstripping
7. Taglio / Montaggio della guarnizione

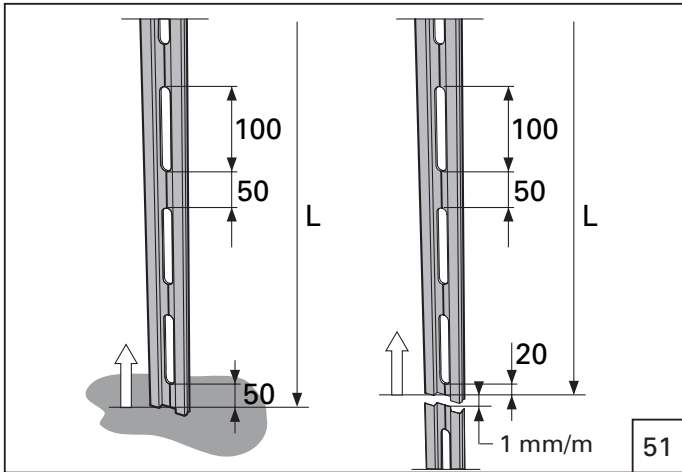

Aussendichtungen vertikal

Zuschnittlänge der Aussendichtung im Postenbereich
 $L + 2 \text{ mm/m}$

Joints extérieurs verticaux

Longueur de coupe du joint extérieur de montant
 $L + 2 \text{ mm/m}$

Outside weatherstripings vertical

Cut length of the outside weatherstripping in the vertical section
 $L + 2 \text{ mm/m}$

Guarnizioni esterne verticali

Lunghezza del taglio della guarnizione esterna nell'ambito del montante $L + 2 \text{ mm/m}$

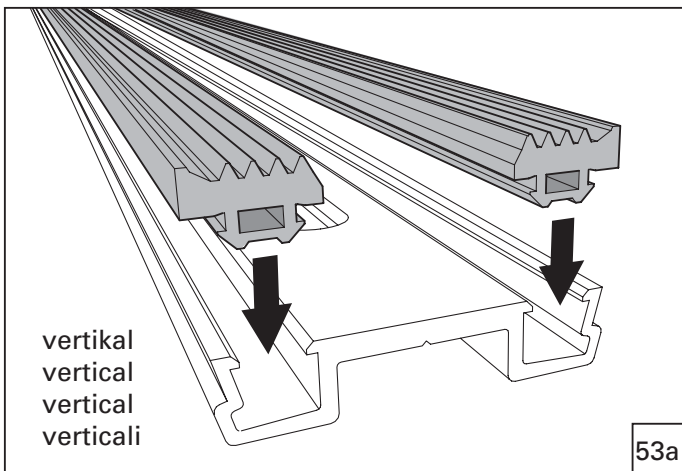
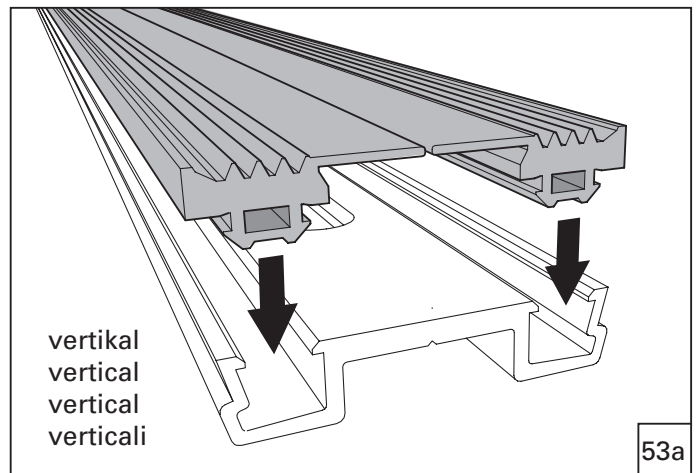
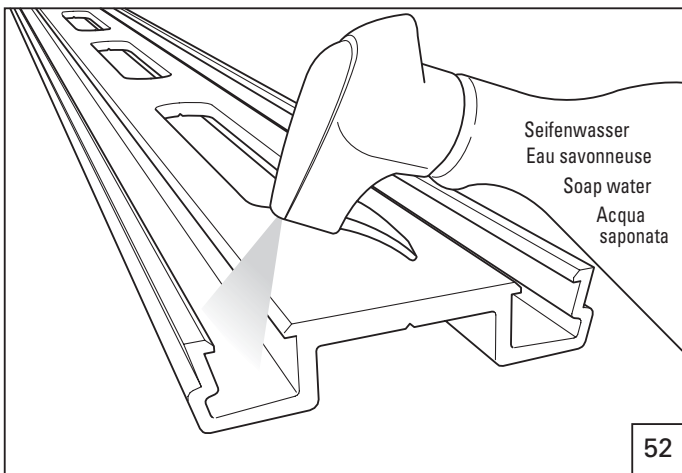

8. Montage der Anpressprofile
Riegelabdeckung mit Anschraubprofil

8. Montage de profilés de fixation
Recouvrement de la traverse avec profilé à visser

8. Assembly the clamping profile
Transom cover with screw-on section

8. Montaggio dei profili di fissaggio
Copertura di traverso con profilo da avvitare

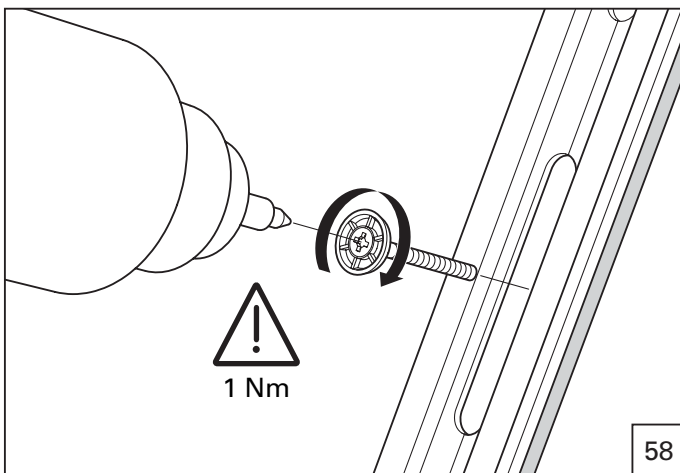
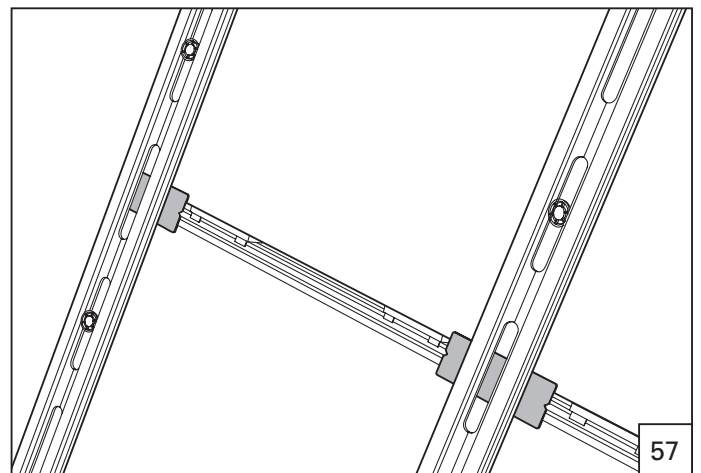
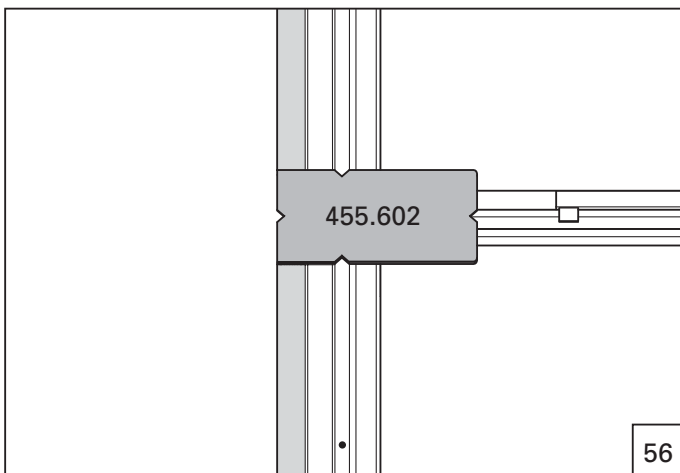
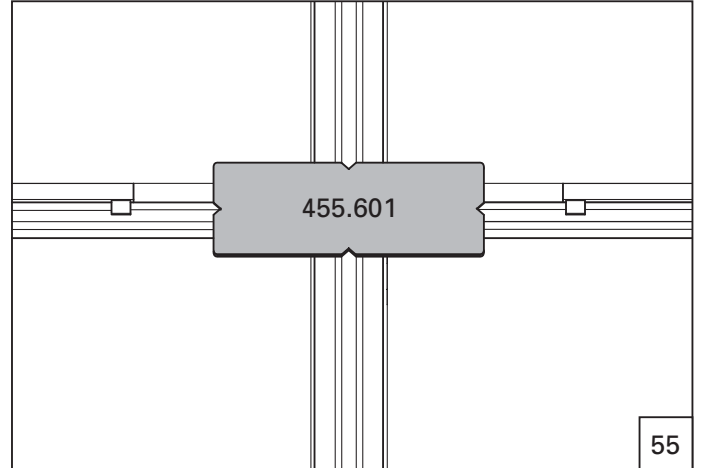
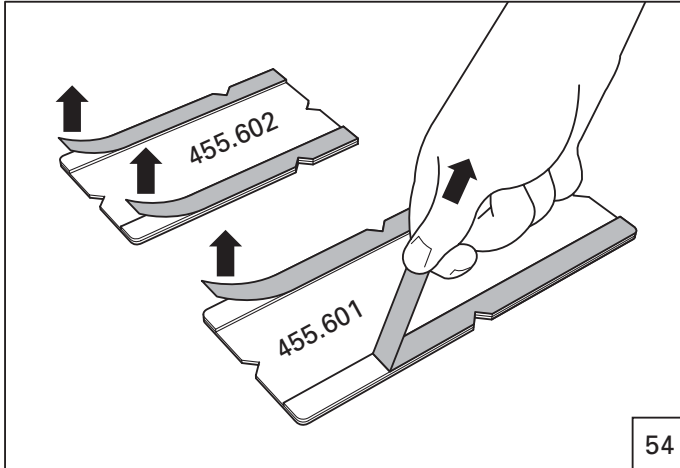

Kontrolle:
Die Aussendichtungen 455.501/503/504/506/507 werden um **0,3 bis 0,5 mm** zusammengepresst.

Contrôle:
Les joints extérieurs 455.501/503/504/506/507 subissent une compression de **0,3 à 0,5 mm**.

Check:
The outside weatherstrippings 455.501/503/504/506/507 are compressed by **0,3 to 0,5 mm**.

Controllo:
Le guarnizioni esterne 455.501/503/504/506/507 vengono compresse di **0,3 fino a 0,5 mm**.

Verarbeitung und Montage VISS TVS (schräg)
Usinage et montage VISS TVS (oblique)

Processing and assembly VISS TVS (sloping)
Lavorazione e montaggio VISS TVS (inclinata)

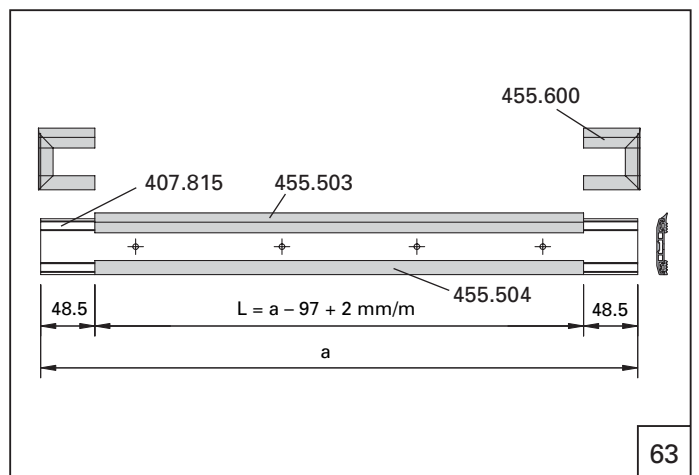
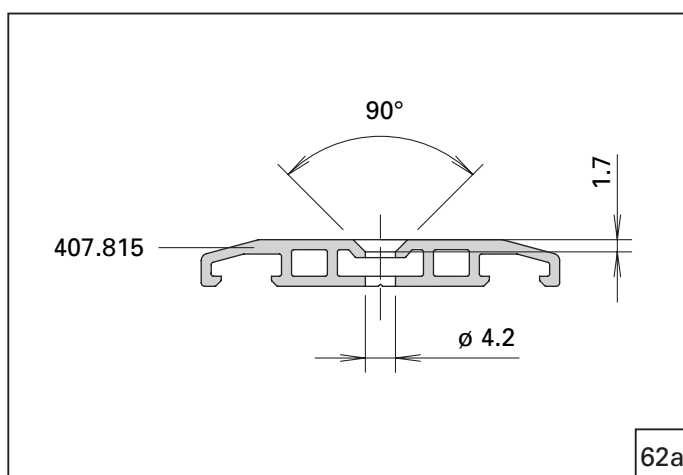
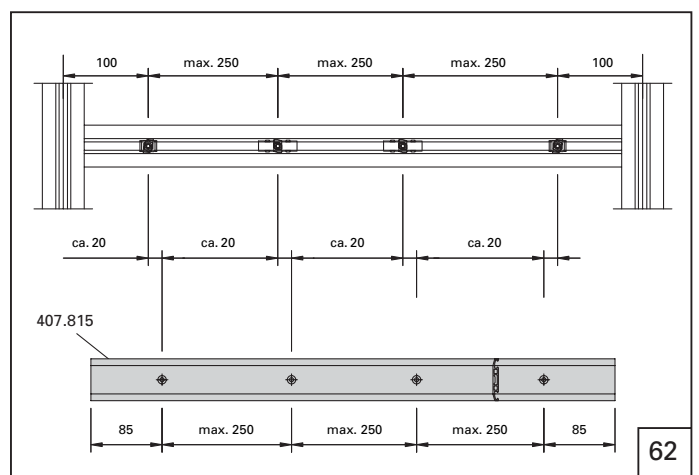
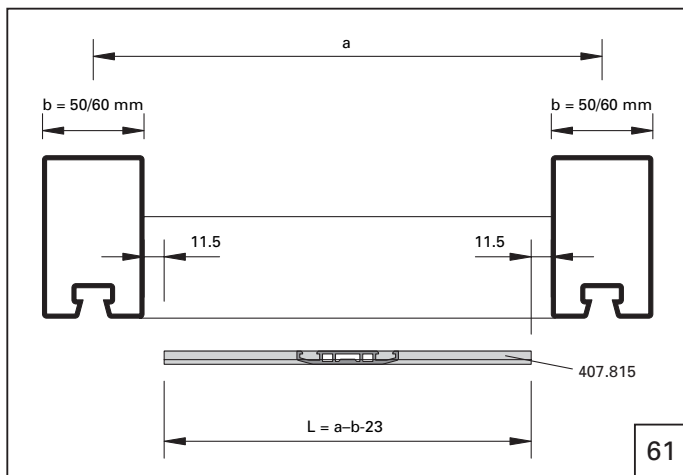
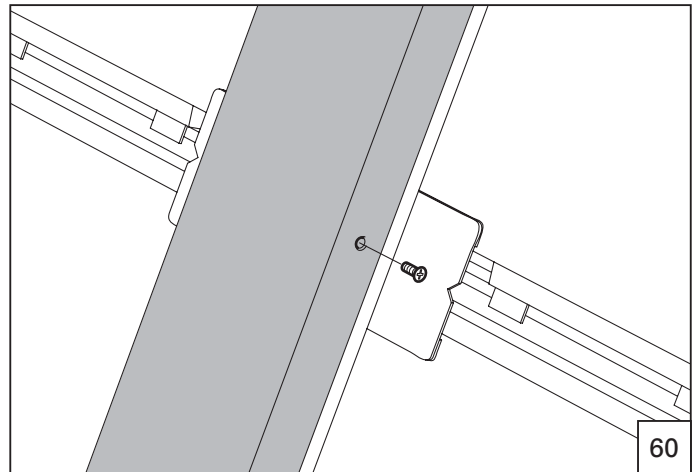
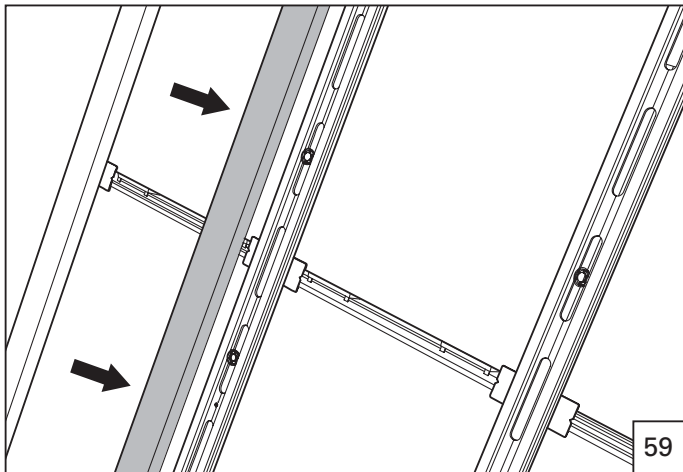

Verarbeitung und Montage VISS TVS (schräg)
Usinage et montage VISS TVS (oblique)

Processing and assembly VISS TVS (sloping)
Lavorazione e montaggio VISS TVS (inclinata)

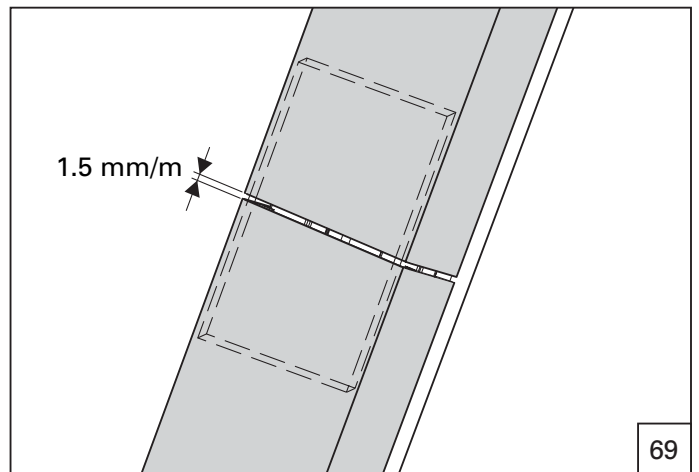
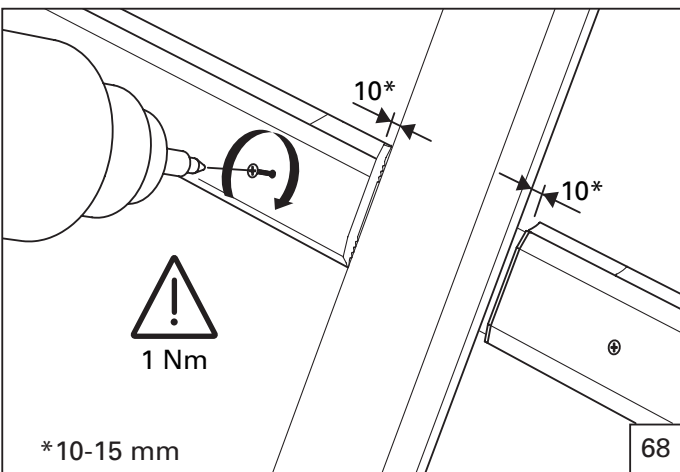
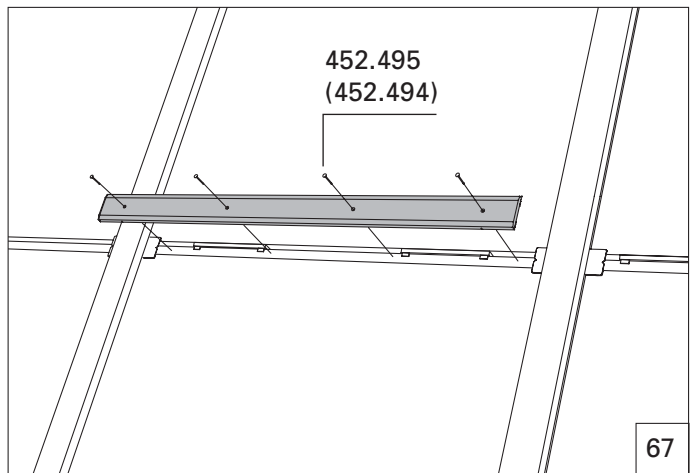
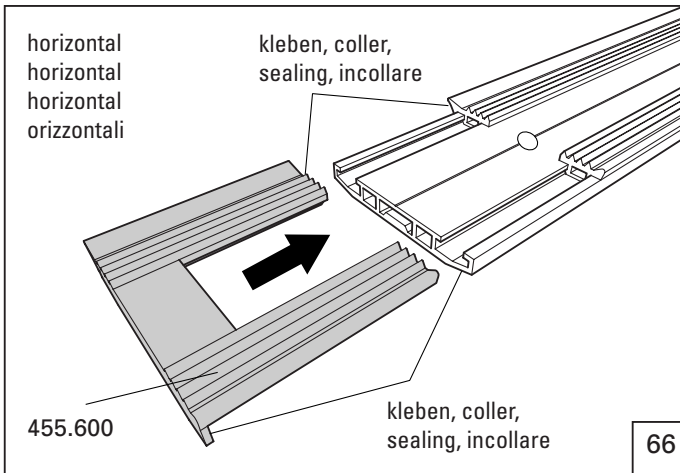
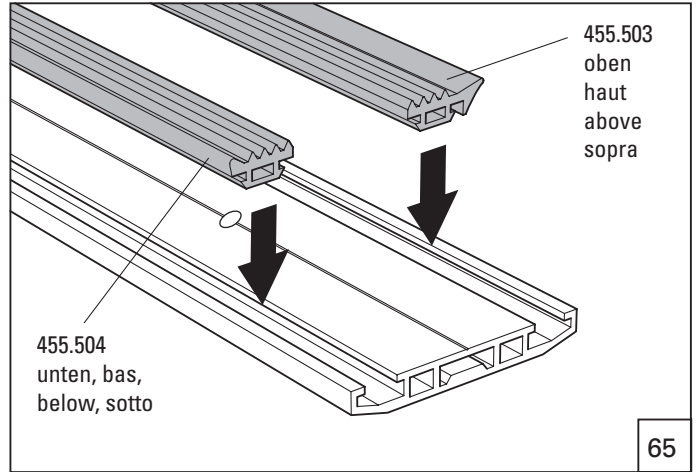
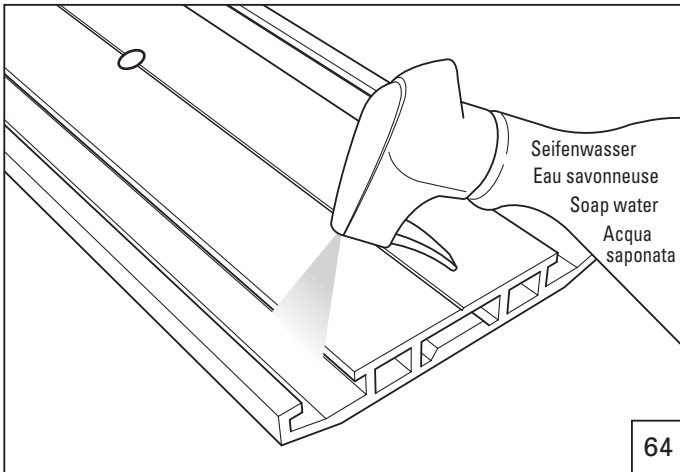

9. Montage der Anpressprofile
Riegelabdeckung mit Anklebeprofile

9. Montage de profilés de fixation
Recouvrement de la traverse avec profilé à coller

9. Assembly the clamping profile
Transom cover with glued-on section

9. Montaggio dei profili di fissaggio
Copertura di traverso con profilo da incollare

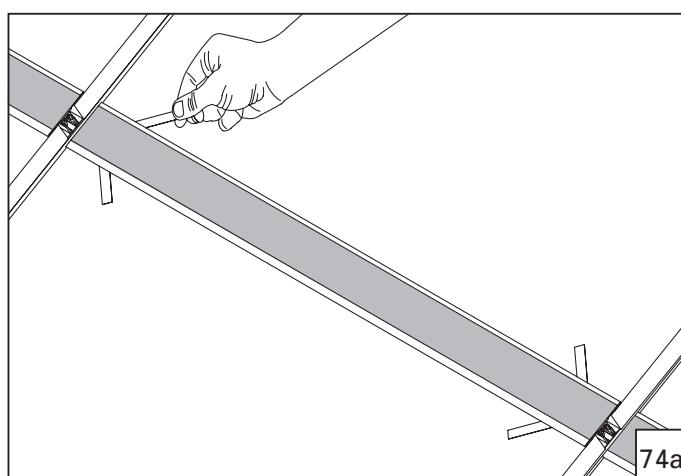
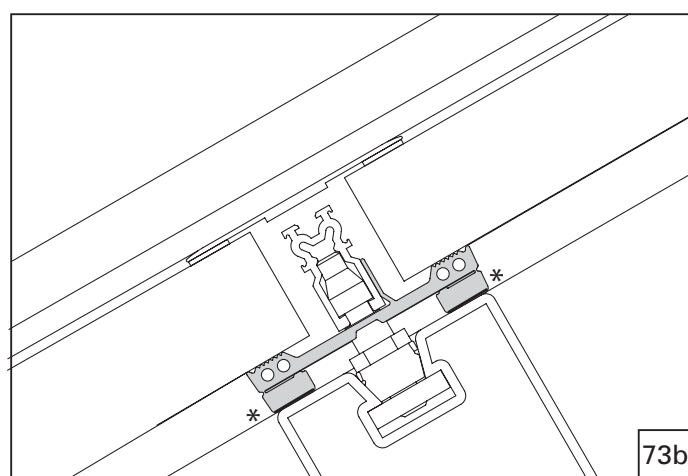
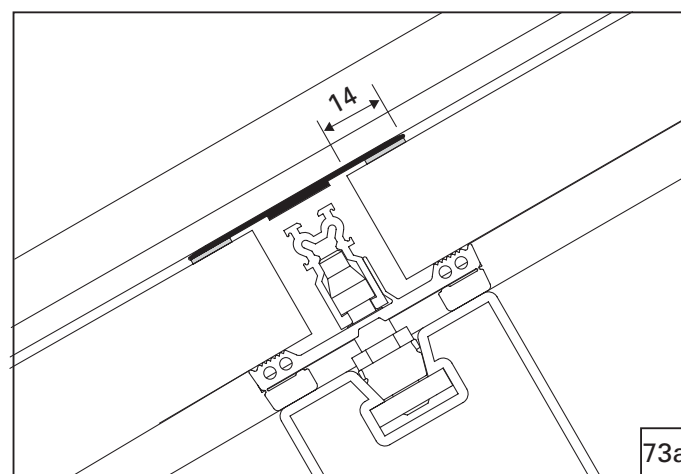
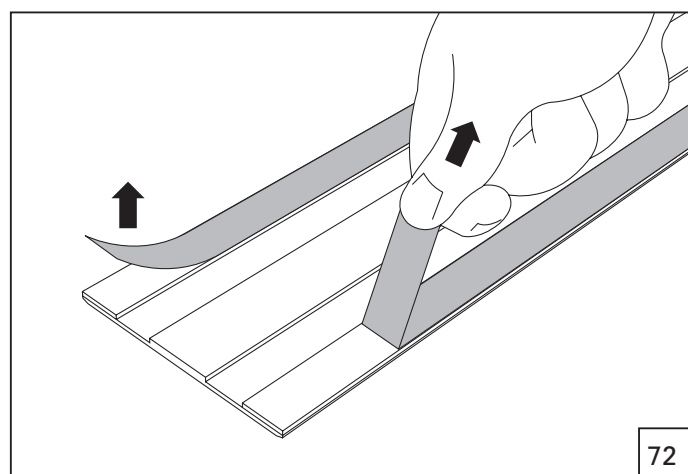
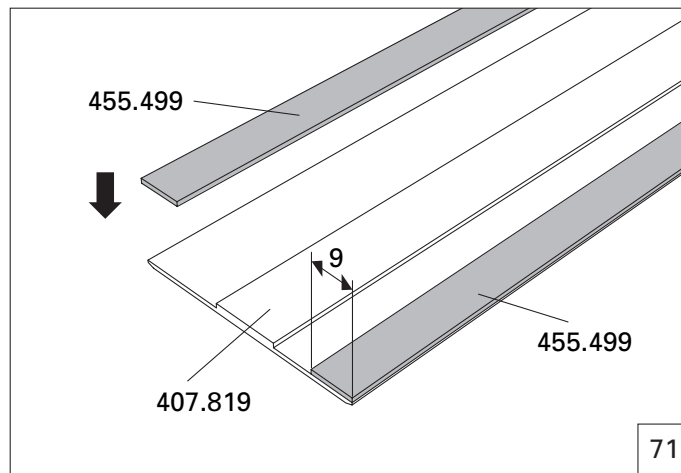
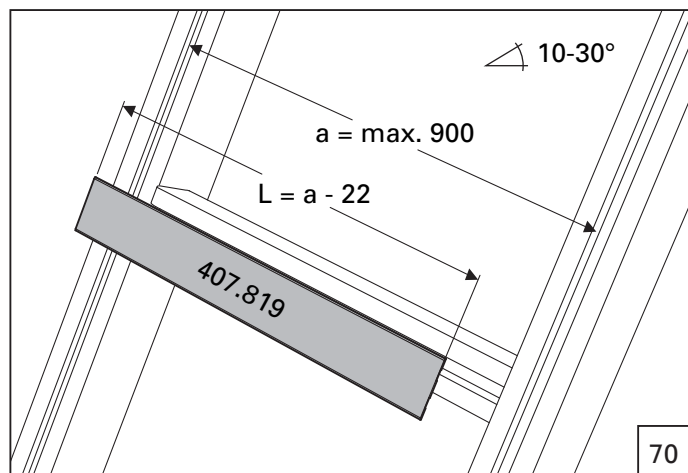

- * Falls Riegel im Zugriffsbereich der Benutzer liegt, Dichtung mit Doppelklebeband sichern.
- * Bloquer le joint avec un ruban adhésif double si la traverse est dans la zone d'accès de l'utilisateur.
- * Should the transom lie within grasp of the user, secure the weatherproofing in place with double-sided tape.
- * Se il traverso è accessibile agli utenti, assicurare la guarnizione con nastro biadesivo.

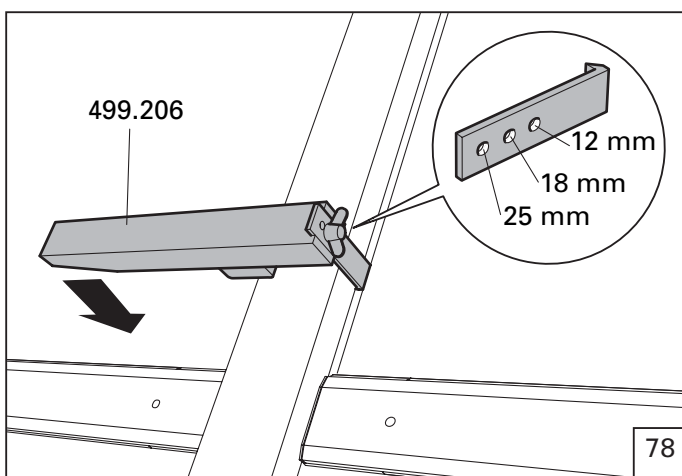
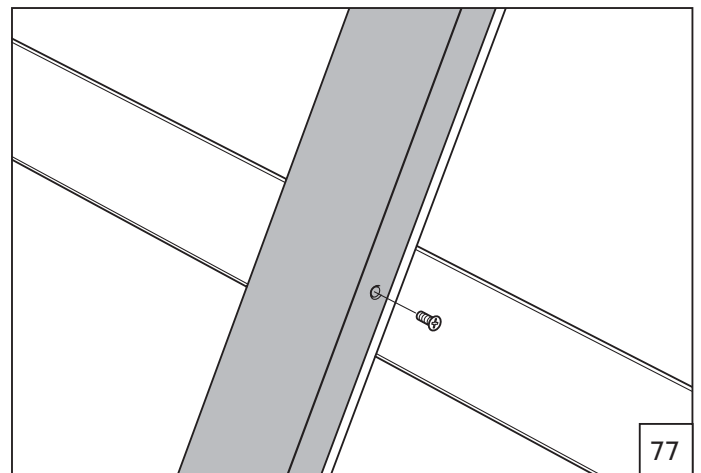
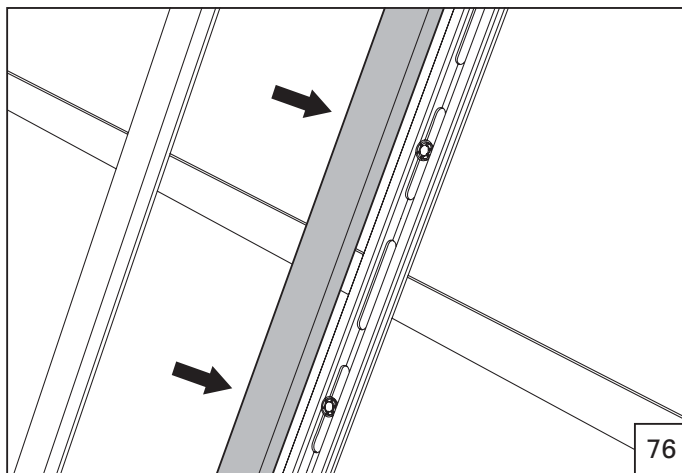
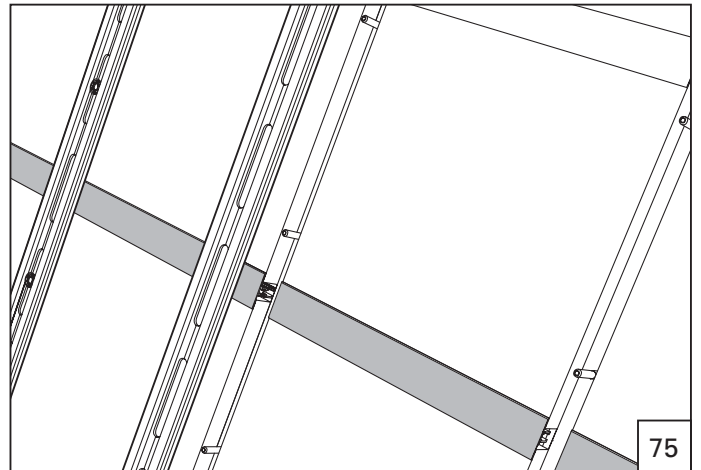
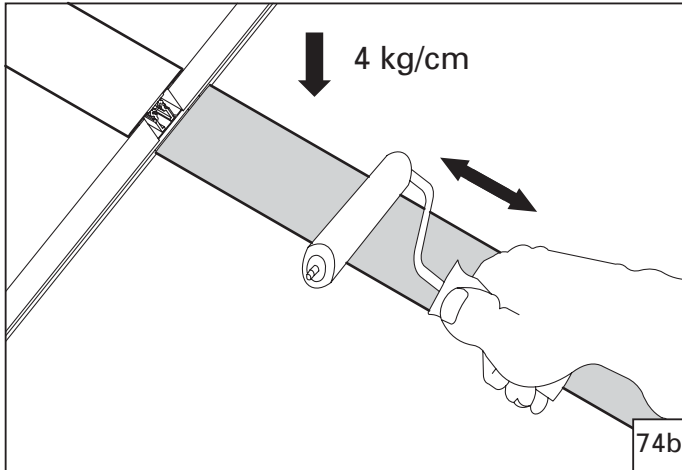

Verarbeitung und Montage VISS TVS (schräg)
Usinage et montage VISS TVS (oblique)

Processing and assembly VISS TVS (sloping)
Lavorazione e montaggio VISS TVS (inclinata)

VISS TVS (schräg) Einfachverglasung 6-10 mm

VISS TVS (sloping) single glazing 6-10 mm

VISS TVS (oblique) vitrage simple 6-10 mm

VISS TVS (inclinata) vetratura semplice 6-10 mm

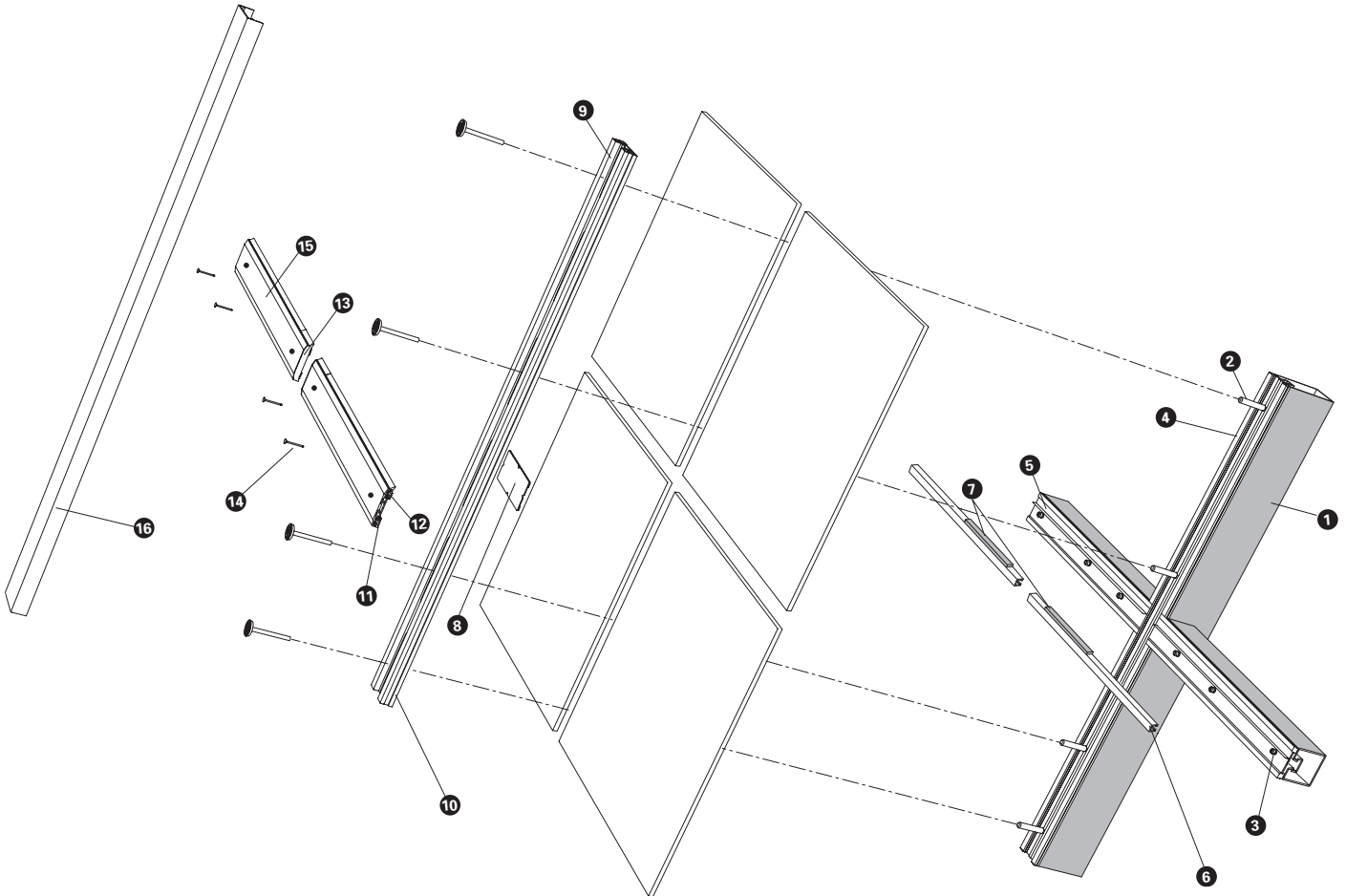

Pos. Artikel

Pos. Article

Pos. Item

Pos. Articolo

- 1 Tragkonstruktion
- 2 Isolationsknopf
- 3 Klemmisolationsknopf/Traganker
- 4 Innendichtung vertikal
- 5 Innendichtung horizontal
- 6 Falzprofil
- 7 Tragklotz
- 8 Dichtplatte
- 9 Anpressprofil
- 10 Aussendichtung vertikal
- 11 Aussendichtung Riegel horizontal, unten
- 12 Aussendichtung Riegel horizontal, oben
- 13 Endstück
- 14 Selbstbohrschraube
- 15 Anschraubprofil
- 16 Abdeckprofil

- 1 Construction porteuse
- 2 Bouton d'isolation
- 3 Bouton d'isolation de serrage/Boulon-support
- 4 Joint intérieur vertical
- 5 Joint intérieur horizontal
- 6 Profilé de feuillure
- 7 Cale de remplissage
- 8 Plaque d'étanchéité
- 9 Profilé de fixation
- 10 Joint extérieur vertical
- 11 Joint extérieur horizontal de traverse, inférieur
- 12 Joint extérieur horizontal de traverse, supérieur
- 13 Embout
- 14 Vis autoforeuse
- 15 Profilé à visser
- 16 Profilé de recouvrement

- 1 Load-bearing structure
- 2 Insulating stud
- 3 Fixing-insulating stud / Supporting bolt
- 4 Inside weatherstripping vertical
- 5 Inside weatherstripping horizontal
- 6 Rebate section
- 7 Glazing support
- 8 Intersection sealing plate
- 9 Clamping section
- 10 Outside weatherstripping vertical
- 11 Outside weatherstripping horizontal, bottom
- 12 Outside weatherstripping vertical, top
- 13 End piece
- 14 Self-cutting screw
- 15 Screw-on section
- 16 Cover section

- 1 Struttura portante
- 2 Bottone d'isolamento
- 3 Bottone d'isolamento a incastro / Bullone di supporto vetro
- 4 Guarnizione interna verticale
- 5 Guarnizione interna orizzontale
- 6 Profilo scanalato supporto vetro
- 7 Blocco di supporto vetro
- 8 Piastra di tenuta
- 9 Profilo di fissaggio
- 10 Guarnizione esterna verticale
- 11 Guarnizione esterna trasverso inferiore
- 12 Guarnizione esterna trasversa superiore
- 13 Terminale
- 14 Vite autofilettante
- 15 Profilo da avvitare
- 16 Profilo di copertura

Verarbeitung und Montage VISS TVS (schräg)
Usinage et montage VISS TVS (oblique)

Processing and assembly VISS TVS (sloping)
Lavorazione e montaggio VISS TVS (inclinata)

Einfachverglasung

Vitrage simple

Die Anordnung und das Einsetzen der Isolationsknöpfe und Traganker, der Einbau der Innendichtungen und der äusseren Anpress- und Abdeckprofile erfolgt sinngemäss wie bei der Isolierverglasung.

Abweichung:

Das Riegel-Falzprofil 407.809 wird nicht aufgeklipst, sondern seitlich über die Traganker geschoben. Dazu sind gemäss Abbildungen die entsprechenden Ausfräsungen vorzunehmen.

La disposition et la pose des boutons d'isolation et des boulons-supports, le montage des joints intérieurs et des profilés extérieurs de fixation et de recouvrement s'effectuent de la même manière que pour le vitrage isolant.

Differenza:

Le profilé de feuillure de traverse 407.809 n'est pas clipsé, mais poussé latéralement sur les boulons-support. Des fraises doivent être effectuées conformément aux figures.

Single glazing

Vetratura semplice

The positioning and insertion of the fixing studs and supporting bolts, the fitting of the inner sealant and the external clamping sections and cover sections takes place in the same manner as for the insulated glazing.

Variance:

The transom rebate section 407.809 is not clipped on, but instead pushed over the supporting bolts sideways. This requires the appropriate recesses to be cut, as shown in the diagrams.

La disposizione e l'applicazione dei bottoni d'isolamento e dei bulloni di supporto, nonché l'inserimento delle guarnizioni interne e dei profili di fissaggio e di copertura esterni vengono effettuati in base alle istruzioni per la vetratura isolante, con la seguente differenza.

Differenza:

Il profilo scanalato del traverso 407.809 non viene applicato a scatto, ma inserito lateralmente sui bulloni di supporto. Per fare ciò, predisporre delle incisioni come indicato nelle figure.

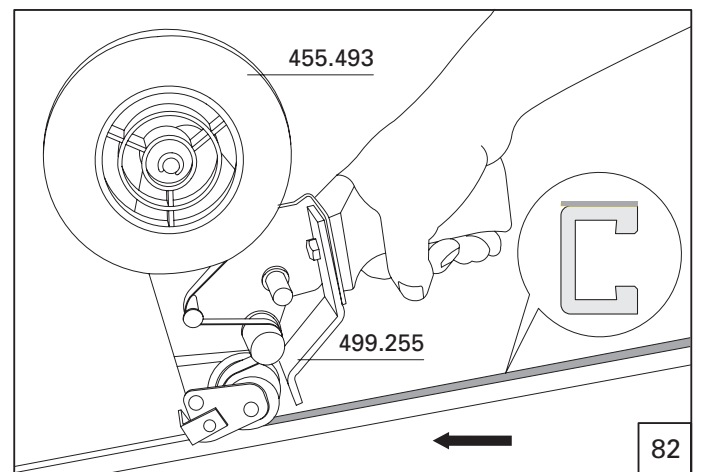
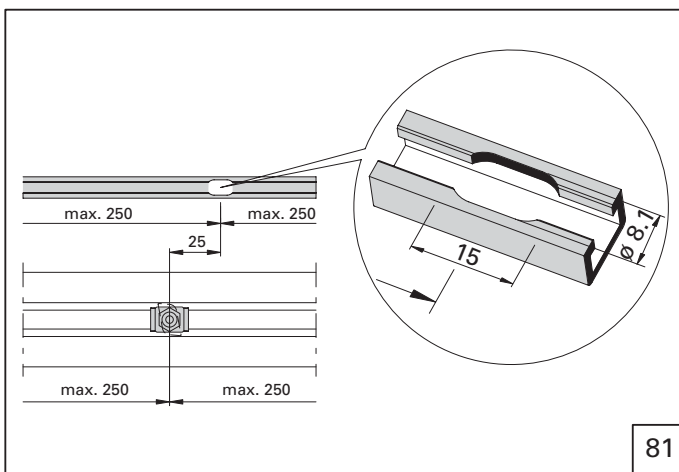
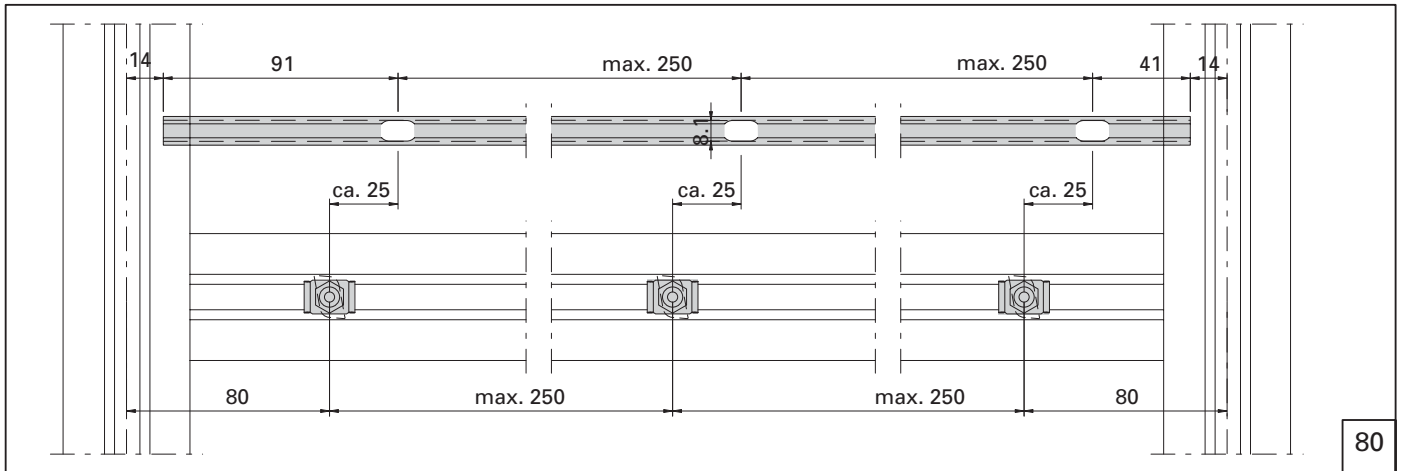

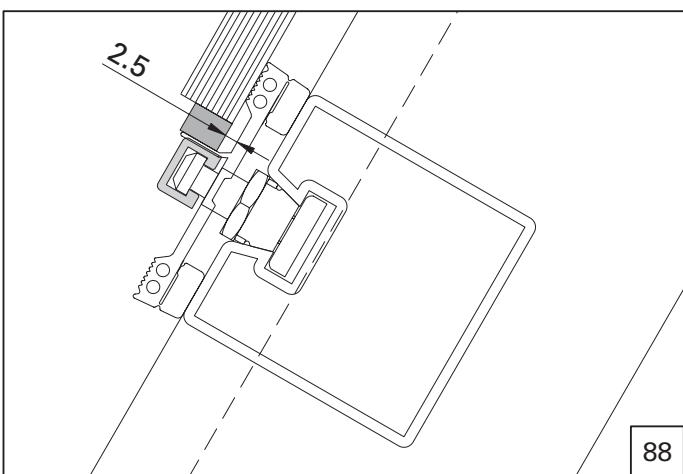
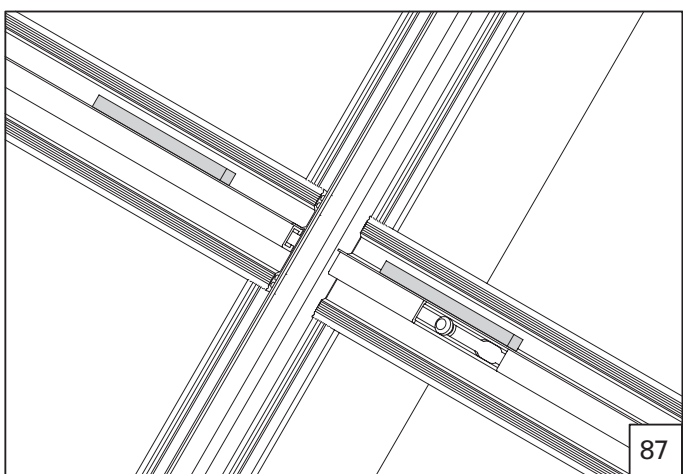
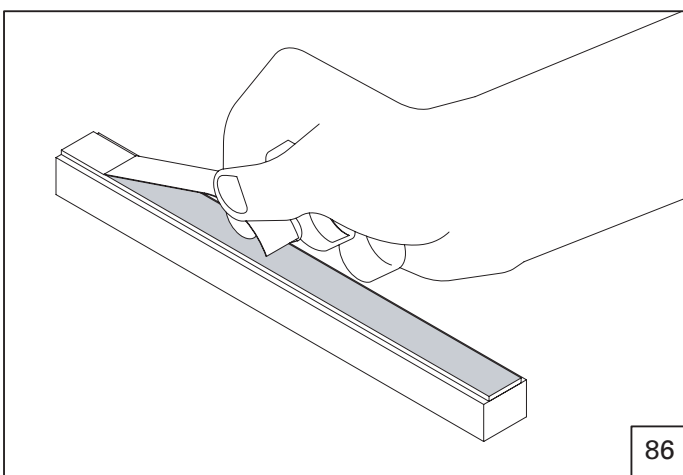
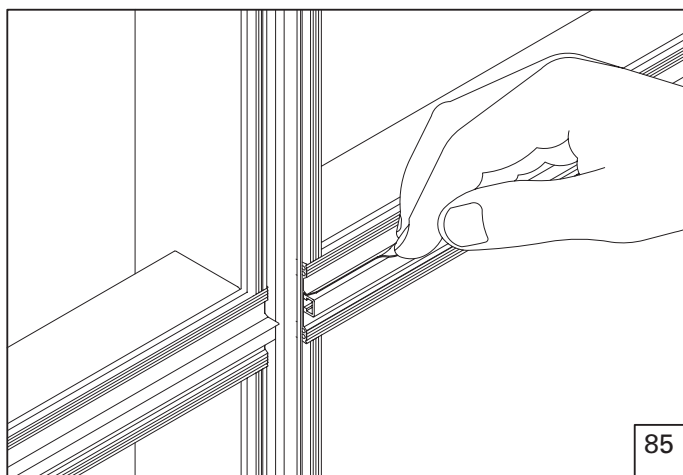
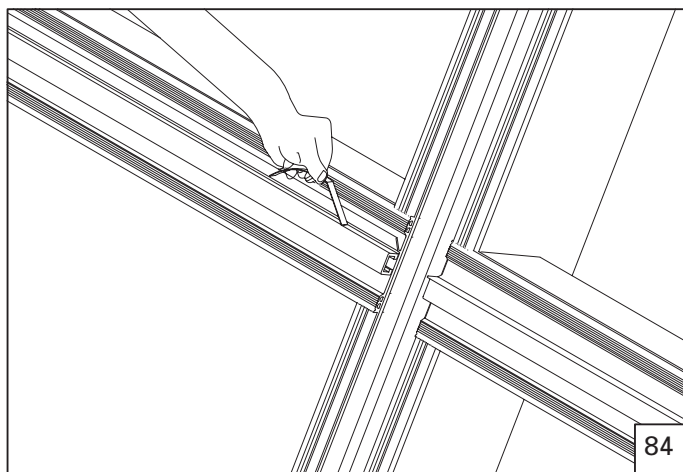
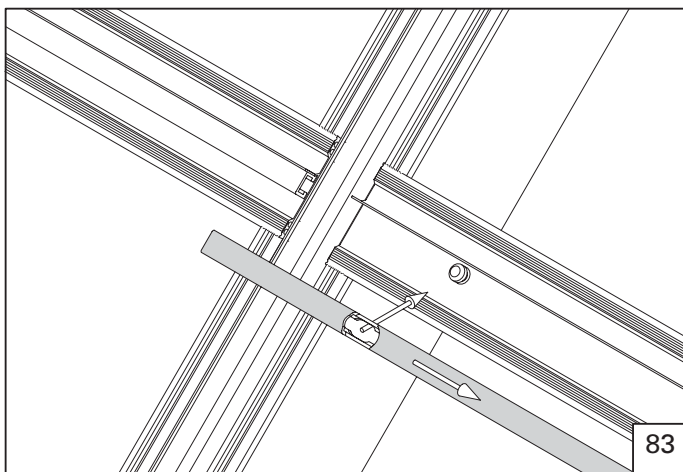

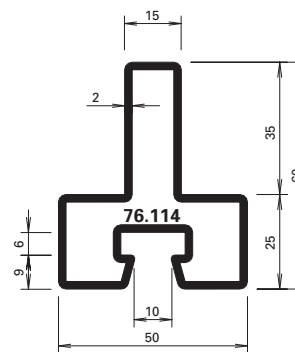
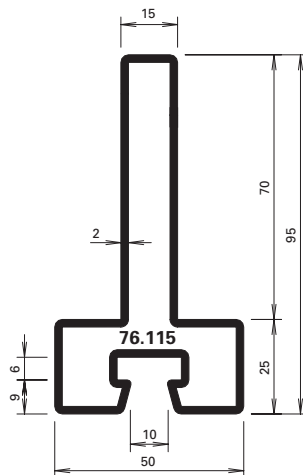
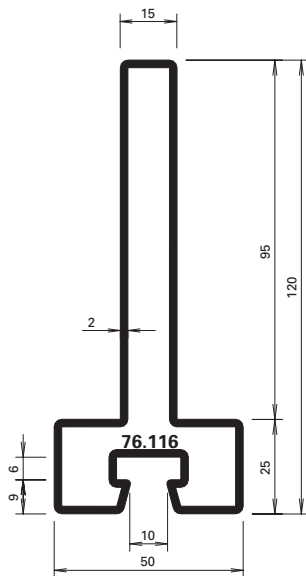
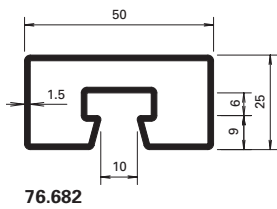
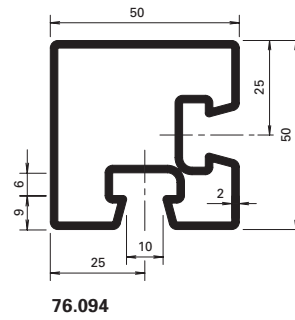
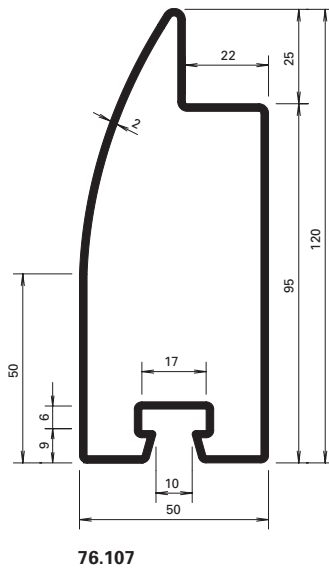
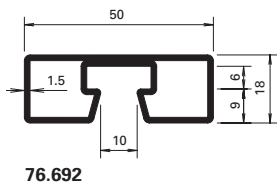
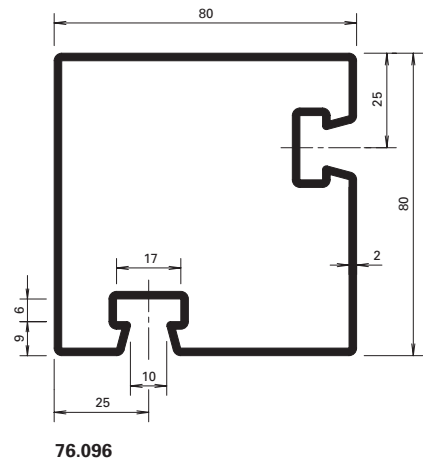
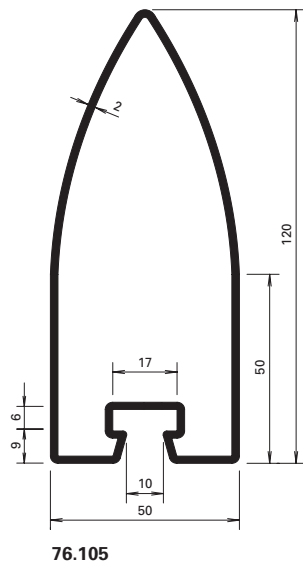
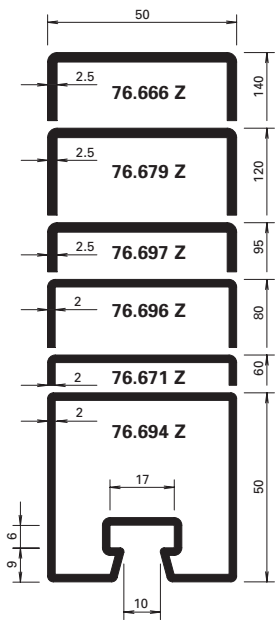

Artikelübersicht
Vue d'ensemble des articles

Article overview
Panoramica articoli

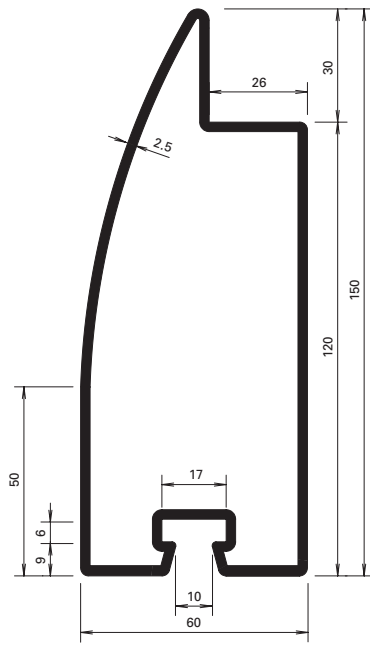
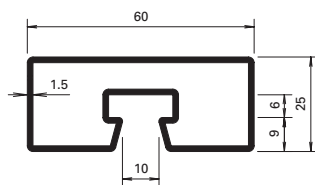
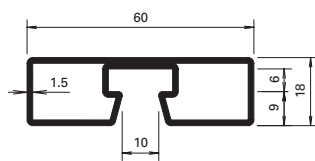
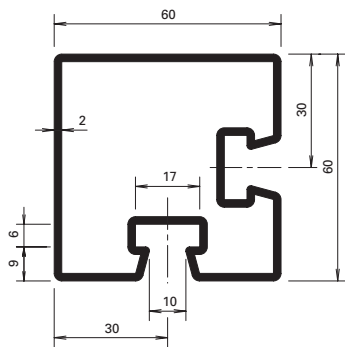
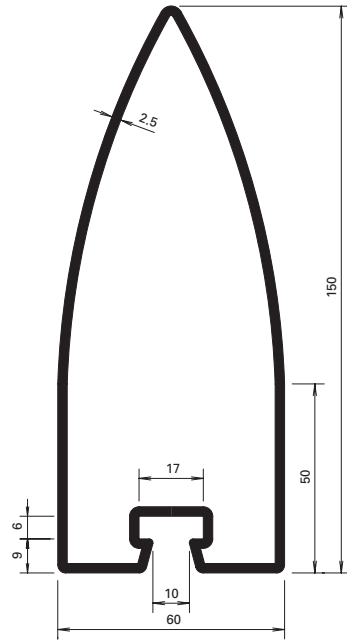
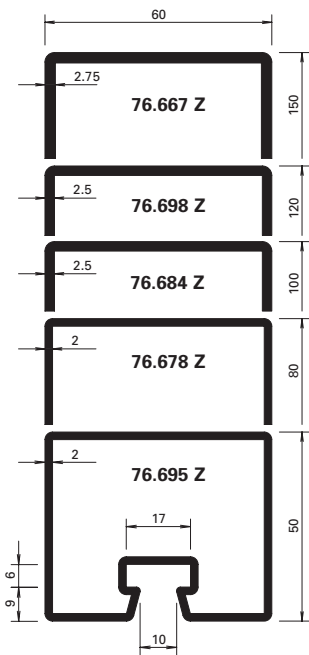

Artikelübersicht
Vue d'ensemble des articles

Article overview
Panoramica articoli

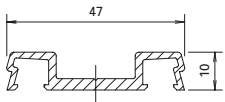

407.800

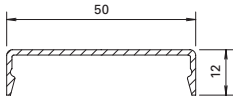

407.860

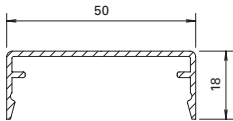

407.861

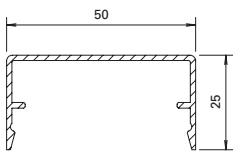

407.862

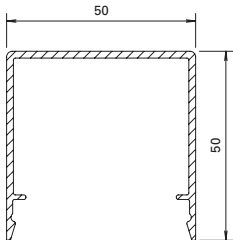

407.863

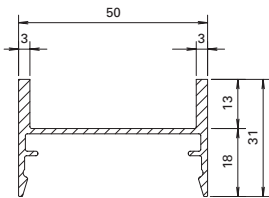

407.900

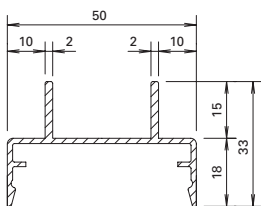

407.911

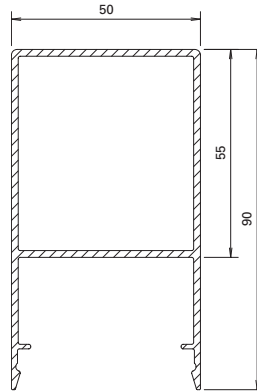

407.864

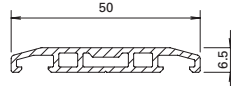

407.815

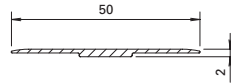

407.819*

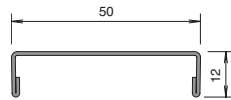

400.860 

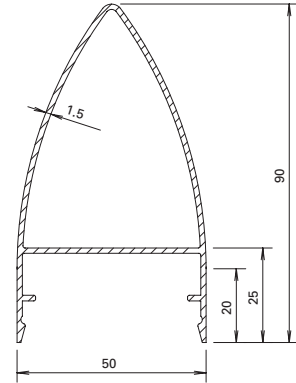

407.914

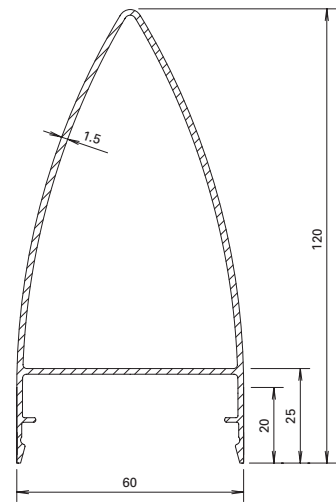

407.915

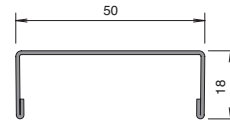

400.861 

* Länge, Longueur, Length, Lunghezza 3 m

Artikelübersicht
Vue d'ensemble des articles

Article overview
Panoramica articoli

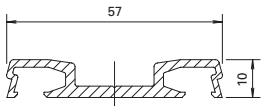

407.802

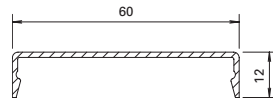

407.865

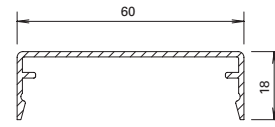

407.866

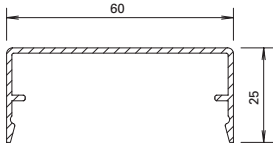

407.867

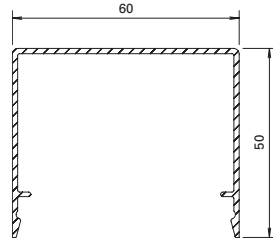

407.868

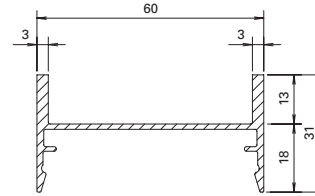

407.901



455.537

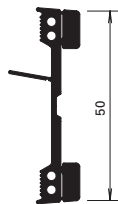

455.541



455.501



455.506

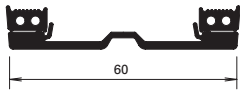

455.538

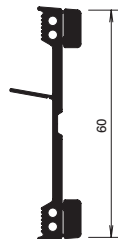

455.542



455.503



455.507

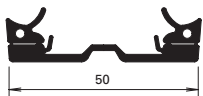

455.545



455.504



455.600

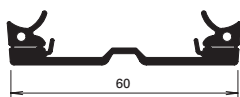

455.546



455.505

Artikelübersicht
Vue d'ensemble des articles

Article overview
Panoramica articoli



452.464
452.465



452.470
452.471
452.473



452.467



455.493



455.499



455.495
455.496



450.095



453.013



450.099

Artikelübersicht
Vue d'ensemble des articles

Article overview
Panoramica articoli



455.423
 455.424

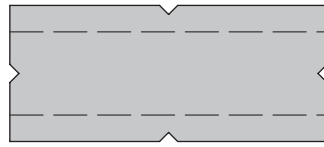

455.601

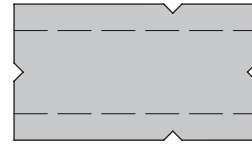

455.602



453.005
 453.006
 453.007
 453.008
 453.009



452.494



452.495

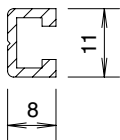

407.809

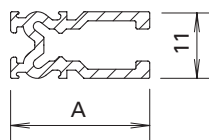

407.810 A = 20 mm
 407.811 A = 23 mm
 407.812 A = 27 mm
 407.813 A = 31 mm
 407.814 A = 36 mm

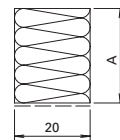

452.310 A = 10 mm
 452.311 A = 20 mm
 452.312 A = 22 mm
 452.313 A = 24 mm
 452.314 A = 26 mm
 452.315 A = 28 mm
 452.316 A = 30 mm

Jansen AG

Stahlröhrenwerk, Kunststoffwerk

CH-9463 Oberriet SG

Tel. +41 (0)71 763 91 11

Fax +41 (0)71 761 22 70

www.jansen.com, info@jansen.com

