

# VISS Fassade

Verarbeitung und Montage

# VISS façade

Usinage et montage

# VISS façade

Processing and assembly

# VISS facciata

Lavorazione e montaggio

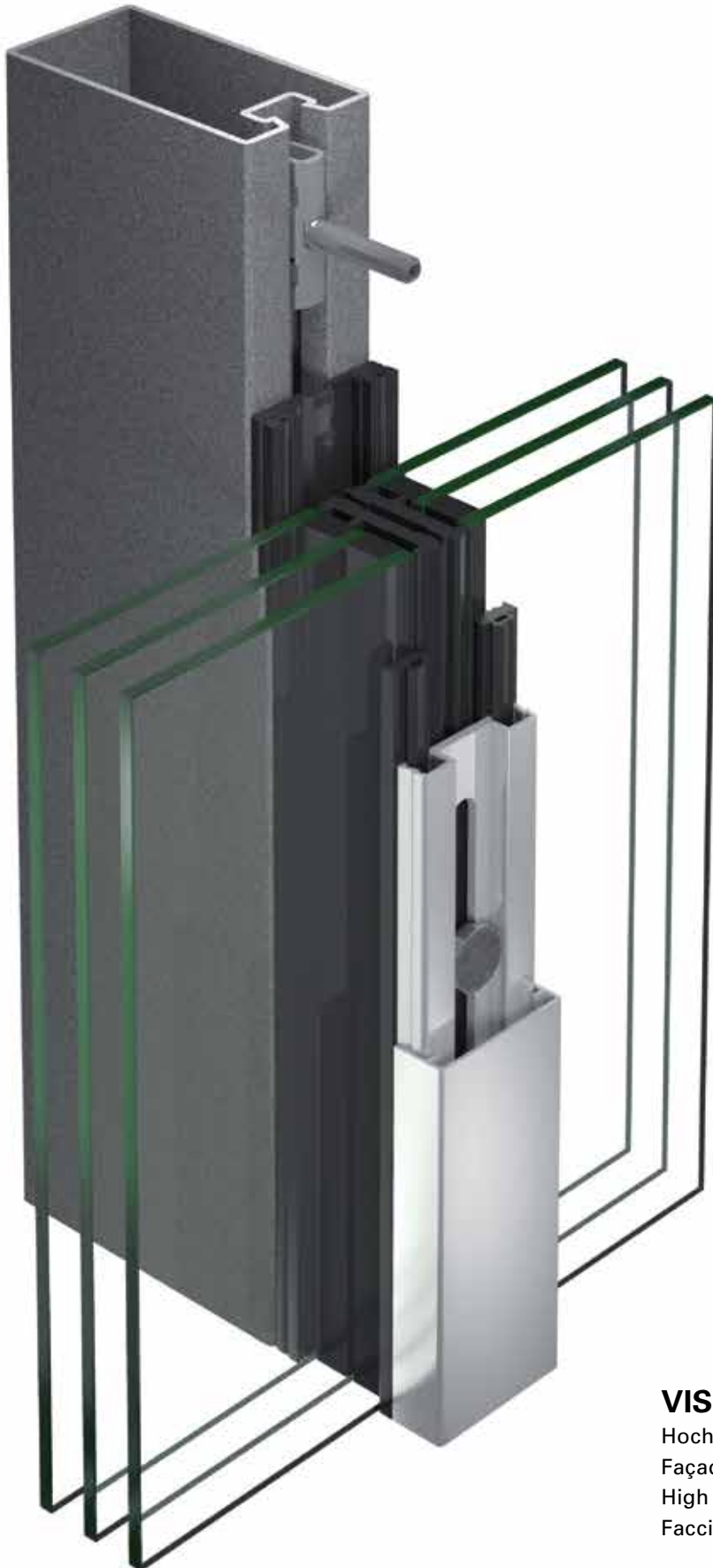

## VISS

Hochwärmegeädämmte Vertikalfassade  
Façade verticale à haute rupture de pont thermique  
High thermally insulated vertical façade  
Facciata verticale con elevato isolamento termico

<b>Systemübersicht</b> <b>Aperçu du système</b>	<b>System overview</b> <b>Panoramica dei sistemi</b>	<b>2</b>
<b>Hinweise</b> <b>Remarques</b>	<b>Information</b> <b>Avvertenze</b>	<b>4</b>
<b>Verarbeitung und Montage</b> <b>Usinage et montage</b>	<b>Processing and assembly</b> <b>Lavorazione e montaggio</b>	<b>9</b>
<b>Montage flaches Deckprofil</b> <b>Montage profilé de recouvrement plat</b>	<b>Assembly flat cover cap</b> <b>Montaggio copertina esterna piatta</b>	<b>58</b>
<b>Artikelübersicht</b> <b>Vue d'ensemble des articles</b>	<b>Article overview</b> <b>Panoramica articoli</b>	<b>66</b>

Alle Ausführungen dieser Dokumentation haben wir sorgfältig und nach bestem Wissen zusammengestellt. Wir können aber keine Verantwortung für die Benützung der vermittelten Vorschläge und Daten übernehmen.

Nous avons apporté le plus grand soin à l'élaboration de cette documentation. Cependant, nous déclinons toute responsabilité pour l'utilisation faite de nos propositions et de nos données.

All the information contained in this documentation is given to the best of our knowledge and ability. However, we decline all responsibility for the use made of these suggestions and data.

Abbiamo dedicato la massima cura alla preparazione della presente documentazione. Decliniamo tuttavia ogni responsabilità per l'uso delle proposte e dei dati da noi forniti.

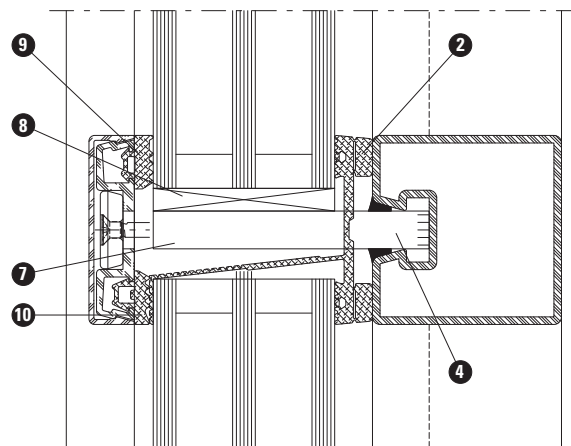
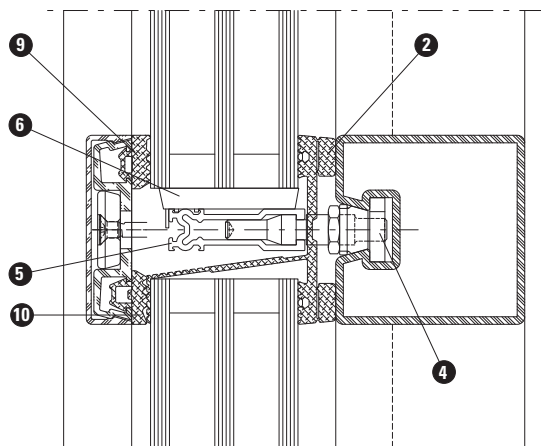
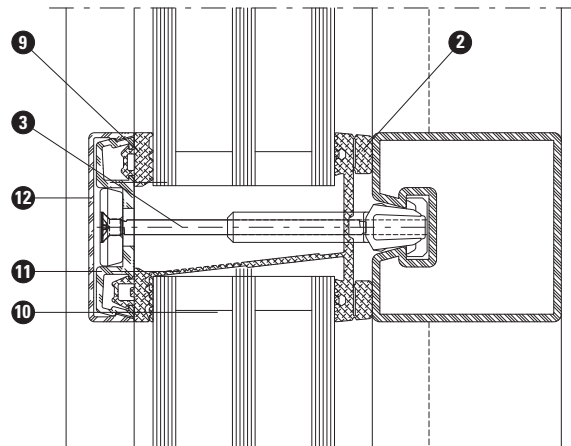
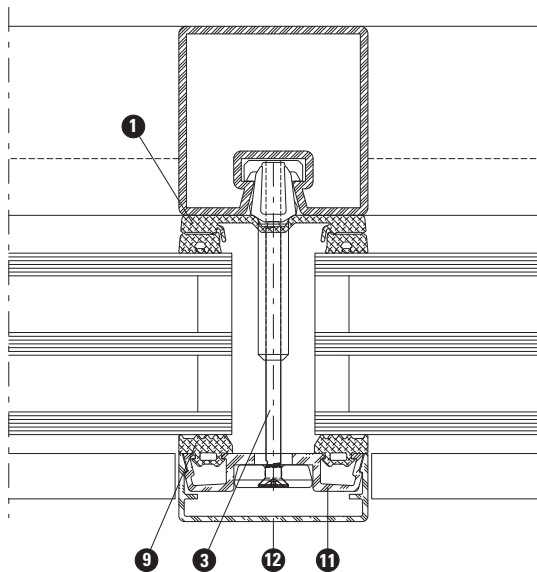

Pos. Artikel

- 1 Innendichtung vertikal
- 2 Innendichtung horizontal
- 3 Isolationsknopf
- 4 Traganker
- 5 Falzprofil
- 6 Tragklotz
- 7 Glasauflager (Sonderlösung)
- 8 Tragklotz (zum Zuschneiden)
- 9 Aussendichtung vertikal / Riegel oben
- 10 Aussendichtung Riegel unten
- 11 Anpressprofil
- 12 Abdeckprofil

Pos. Article

- 1 Joint intérieur vertical
- 2 Joint intérieur horizontal
- 3 Bouton d'isolation
- 4 Boulon-support
- 5 Profilé de feuillure
- 6 Cale de remplissage
- 7 Support de verre (Solution spéciale)
- 8 Cale de remplissage (à découper)
- 9 Joint extérieur vertical / traverse en haut
- 10 Joint extérieur horizontal traverse inférieur
- 11 Profilé de fixation
- 12 Profilé de recouvrement

Pos. Item

- 1 Inner gasket vertical
- 2 Inner gasket horizontal
- 3 Insulating stud
- 4 Supporting bolt
- 5 Rebate section
- 6 Glazing support
- 7 Glazing support (Customised solution)
- 8 Glazing support (for cutting)
- 9 Outer gasket vertical / transom top
- 10 Outer gasket transom bottom
- 11 Clamping section
- 12 Cover section

Pos. Articolo

- 1 Guarnizione interna verticale
- 2 Guarnizione interna orizzontale
- 3 Bottone d'isolamento
- 4 Bullone di supporto vetro
- 5 Profilo scanalato supporto vetro
- 6 Blocco di supporto vetro
- 7 Supporto vetri (Soluzione speciale)
- 8 Blocco di supporto vetro (da tagliare)
- 9 Guarnizione esterna verticale / traverso superiore
- 10 Guarnizione esterna traverso inferiore
- 11 Profilo di fissaggio
- 12 Profilo di copertura

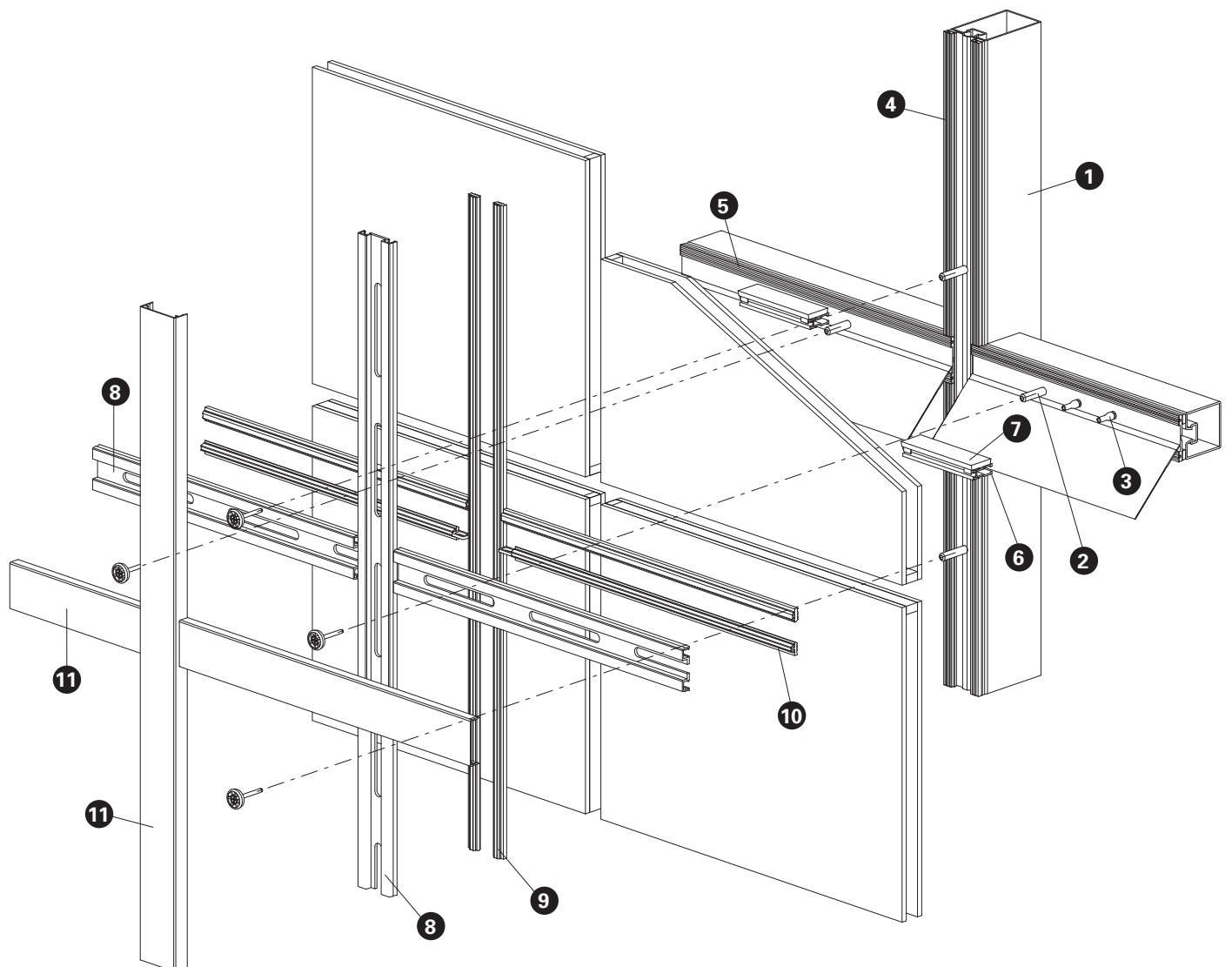

Pos. Artikel	Pos. Article	Pos. Item	Pos. Articolo
1 Tragkonstruktion	1 Construction porteuse	1 Load-bearing structure	1 Struttura portante
2 Isolationsknopf	2 Bouton d'isolation	2 Insulating stud	2 Bottone d'isolamento
3 Traganker	3 Boulon-support	3 Supporting bolt	3 Bullone di supporto vetro
4 Innendichtung vertikal	4 Joint intérieur vertical	4 Inside gasket vertical	4 Guarnizione interna verticale
5 Innendichtung horizontal	5 Joint horizontal intérieur	5 Inside gasket horizontal	5 Guarnizione interna orizzontale
6 Falzprofil	6 Profilé de feuillure	6 Rebate section	6 Profilo scanalato supporto vetro
7 Tragklotz	7 Cale de remplissage	7 Glazing support	7 Blocco di supporto vetro
8 Anpressprofil	8 Profilé de fixation	8 Clamping section	8 Profilo di fissaggio
9 Aussendichtung vertikal	9 Joint vertical extérieur	9 Outside gasket vertical	9 Guarnizione esterna verticale
10 Aussendichtung horizontal	10 Joint horizontal extérieur	10 Outside gasket horizontal	10 Guarnizione esterna orizzontale
11 Abdeckprofil	11 Profilé de recouvrement	11 Cover section	11 Profilo di copertura

Artikel in Abhängigkeit der Füllelementstärke

Items depending on thickness of infill elements

Articles en fonction de l'éléments de remplissage

Articoli in funzione dello spessore degli elementi di riempimento

F mm	Isolationsknopf Bouton d'isolation Insulating stud Bottone isolante			Traganker Boulon-support Supporting bolt Bullone di supporto				Falzprofil Profilé de feuillure Rebate section Profilo d'appoggio						Glasauflage eingeschweisst Support de verre soudé Glazing support welding Supporto vetro saldato	Tragklotz Cale pour remplissage Glazing support Tassello di supporto vetro							
	①			②				③								④						
	452.464	452.465	452.466		452.473	452.469	452.470	452.471	407.809	407.808	407.810	407.811	407.812	407.813	407.814	Flachstahl 100 x 10 mm Acier plat 100 x 10 mm Flat steel 100 x 10 mm Piastra in acciaio 100 x 10 mm	453.013	453.002	453.003	453.004	453.010	453.078
06 – 11	●				●				●								●					●
12 – 15	●					●				●												●
16 – 19	●						●				●											●
20 – 23	●						●				●							●				●
24 – 26		●					●					●						●				●
27 – 30		●						●					●					●				●
31 – 35		●						●						●					●			●
36 – 40		●						●							●					●		●
41 – 45		●														F + 25 mm						●
46 – 70			●																			

- optional auch möglich
- aussi possible en option
- optional also possible
- possibile anche come opzione

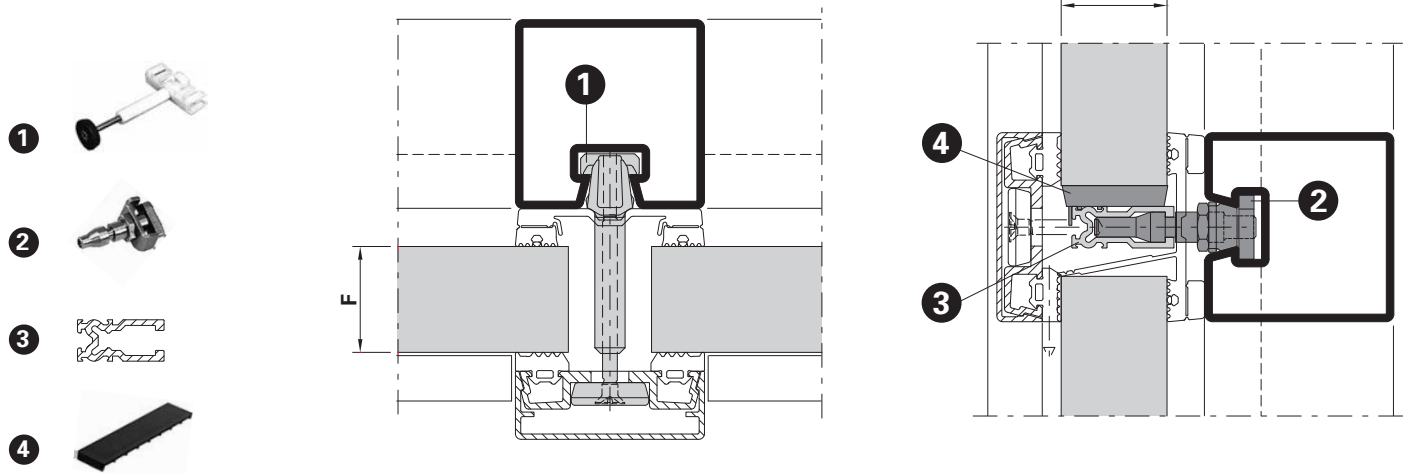

Flaches Deckprofil

Profilé de recouvrement plat

Flat cover cap

Copertina esterna piatta

	Isolationsknopf Bouton d'isolation Insulating stud Bottone isolante			Traganker Boulon-support Supporting bolt Bullone di supporto			Falzprofil Profilé de feuillure Rebate section Profilo d'appoggio					Glasauflage eingeschweisst Support de verre soudé Glazing support welding Supporto vetro saldato	Tragklotz* Cale pour remplissage* Glazing support* Tassello di supporto vetro*	
	1			2			3						4	
<b>F</b> mm	452.410	452.411	452.412	452.469	452.470	452.471	407.808	407.810	407.811	407.812	407.813	407.814	Flachstahl 100 x 10 mm Acier plat 100 x 10 mm Flat steel 100 x 10 mm Piastra in acciaio 100 x 10 mm	453.078
20 – 24	•			•			•						T = F	
25 – 27	•				•			•						
28 – 31	•				•				•					
32 – 35	•					•				•				
36 – 40		•				•					•			
41 – 45		•				•						•		
46 – 55		•												
56 – 70			•										F + 16 mm	

- \* vordere Kante 45° zuschneiden, Minstdicke Aussenscheibe 4 mm (auch im VSG)
- \* couper l'arrête avant à 45°, épaisseur minimale de la vitre extérieure 4 mm (également en VSG)
- \* cut front edge at 45°, minimum thickness of outer pane = 4 mm (also for LSG)
- \* tagliare il bordo anteriore a 45°, spessore minimo della rondella esterna 4 mm (anche nel VSG)

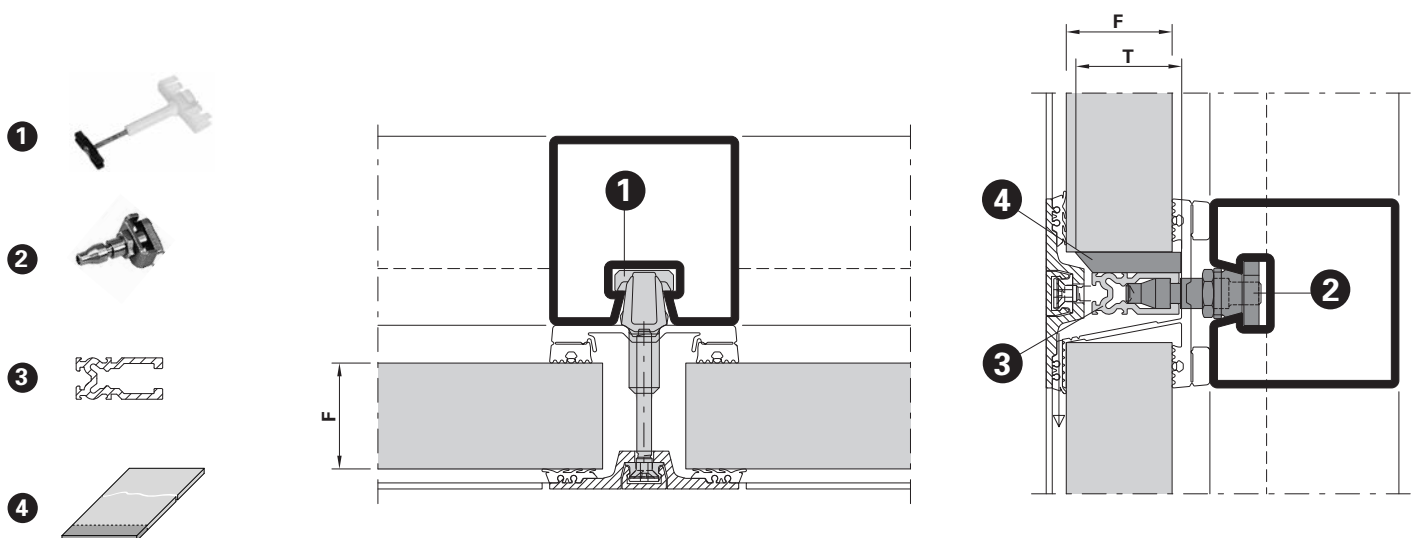

Hinweise VISS Fassade  
Remarques VISS façade  
Information VISS façade  
Avvertenze VISS facciata

VISS Fassade  
VISS façade  
VISS façade  
VISS facciata

**Anwendungsbereich**

**Domaine d'application**

**Scope of application**

**Campo d'applicazione**

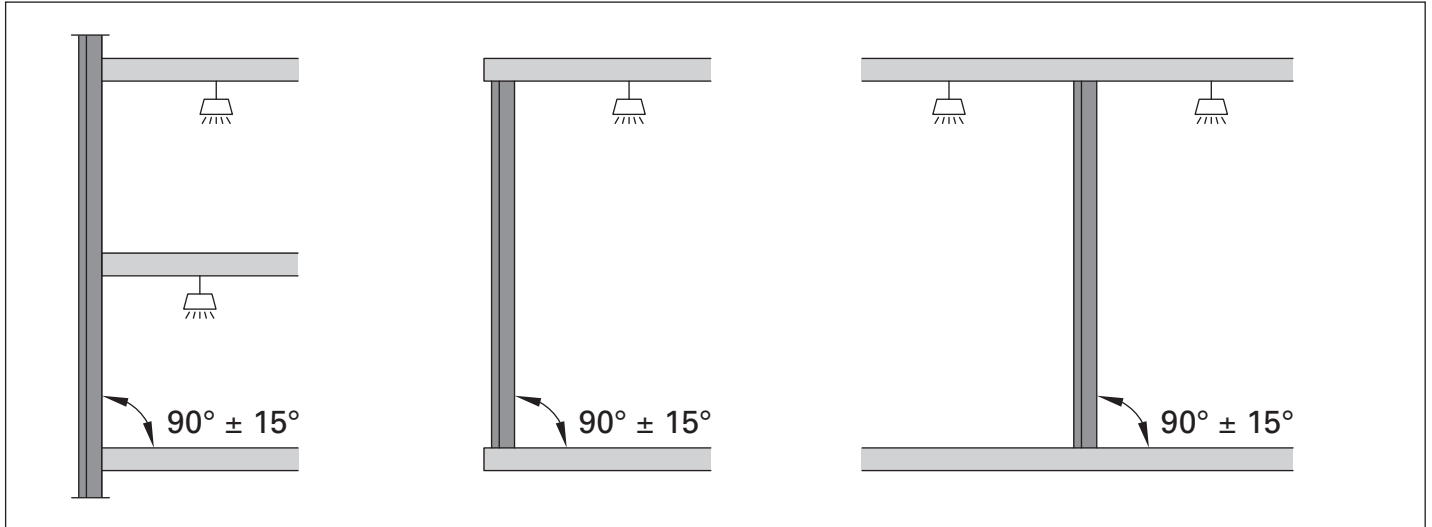



**Verarbeitungs- und Montagebedingungen**

**Conditions de montage et d'usinage**

**Processing and assembly conditions**

**Condizioni di lavorazione e montaggio**

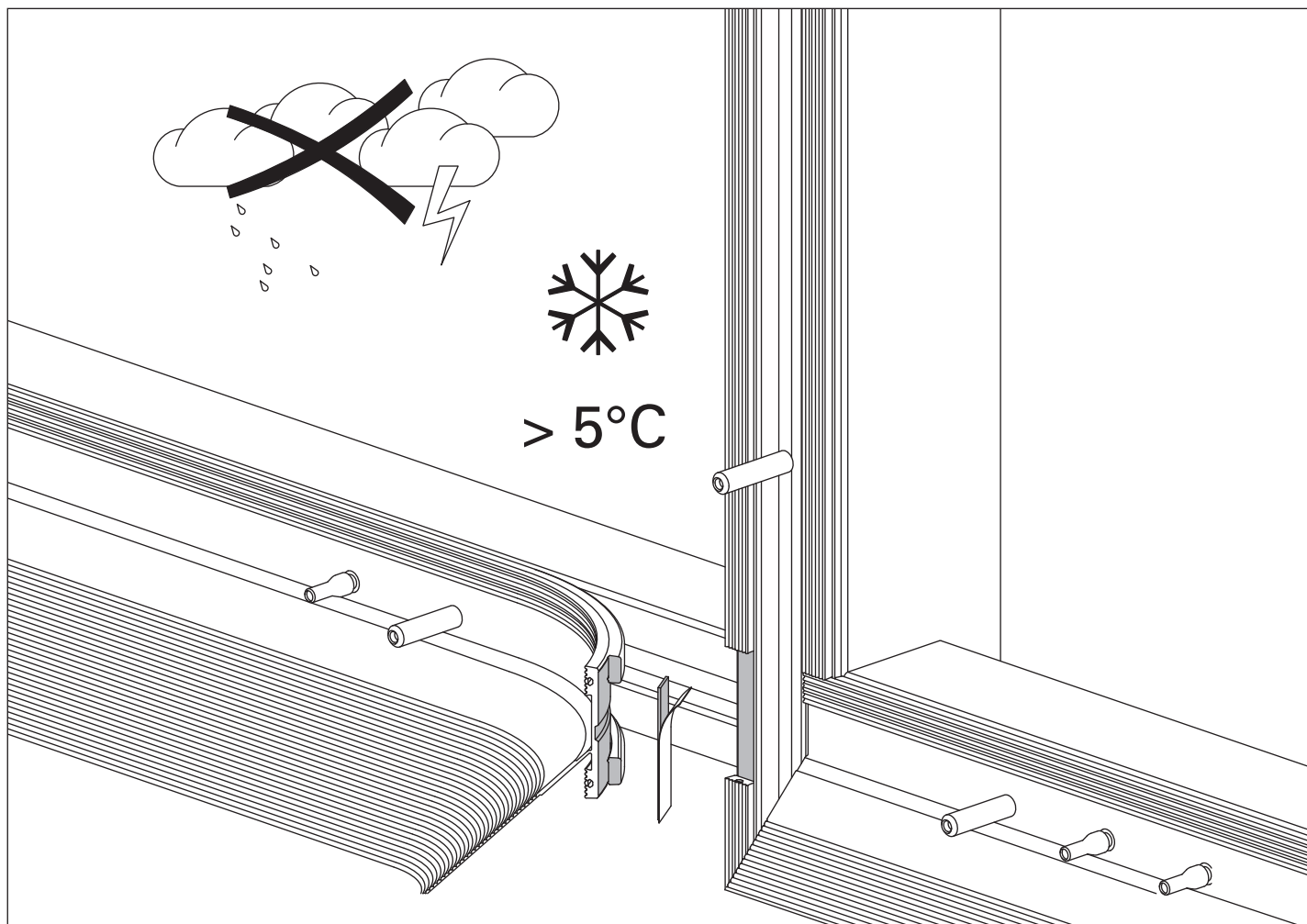

Eine einwandfreie Verklebung ist nur bei trockenen Dichtungen und Umgebungstemperaturen von  $> 5^{\circ}\text{C}$  gewährleistet

Un collage parfait n'est assuré que quand les joints sont secs et les températures ambiantes  $> 5^{\circ}\text{C}$

Proper bonding can only be ensured with dry gaskets and ambient temperatures of  $> 5^{\circ}\text{C}$

Il corretto incollaggio è garantito solo con guarnizioni asciutte e temperature esterne superiori a  $> 5^{\circ}\text{C}$

**Glasfalz-Belüftung/Glasfalz-Entwässerung**

**Ventilation de feuillures de verre/Drainage de la feuillure à verre**

**Glazing rebate ventilation /Glazing rebate drainage**

**Aerazione vetro/drenaggio vetro**

Detail 2

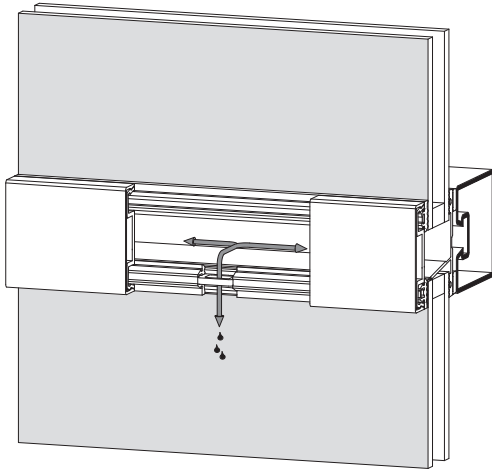

Detail 1

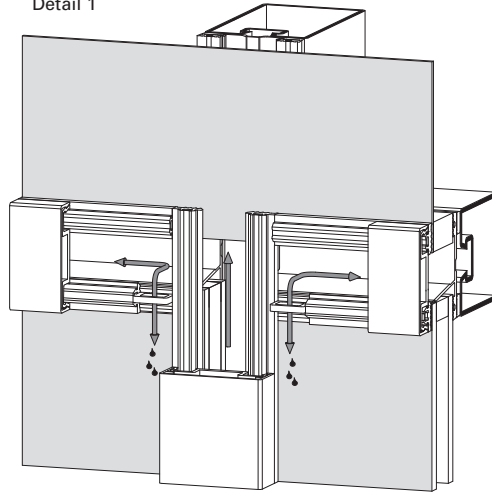

Detail 3

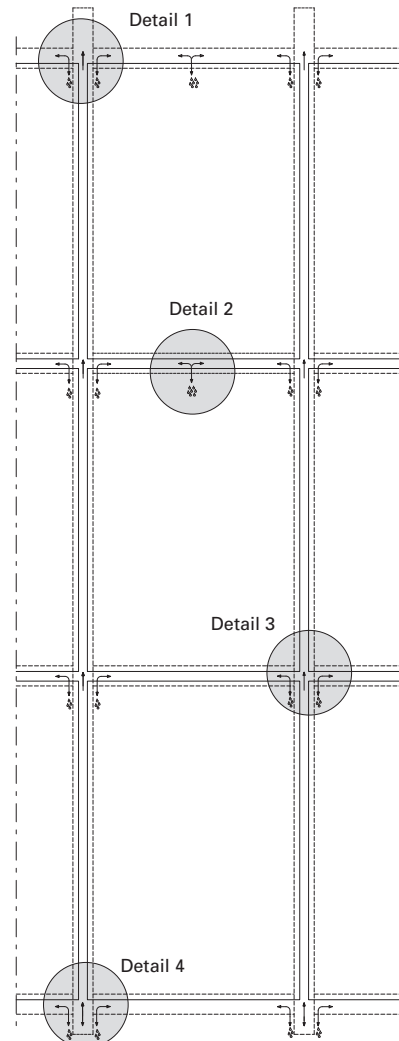
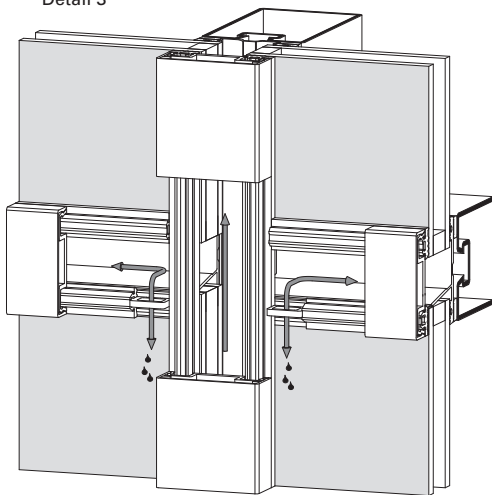

Detail 4

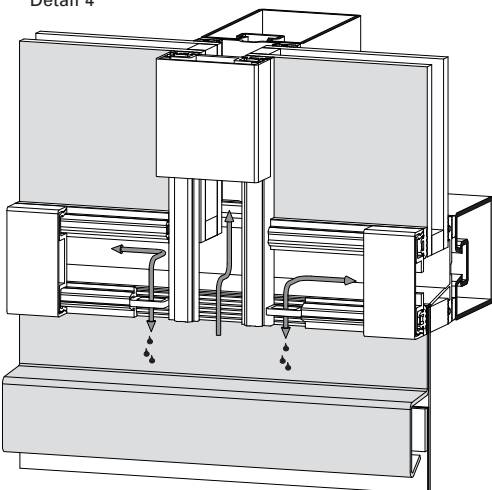

**Ablaufschritte: Verarbeitung und Montage**

	Seite
1. Übersicht Bauweise	10
2. Anordnung und Montage Isolationsknöpfe	14
3. Anordnung und Montage Glasauflagen	19
4. Zuschnitt / Montage / Ausklinkung der Innendichtung vertikal	23
5. Zuschnitt und Ausklinkung der Innendichtung horizontal	27
6. Montage Innendichtung horizontal	30
7. Montage Glasauflage und Glasklotz	38
8. Glaseinstand	40
9. Einbau Füllelemente	41
10. Zuschnitt und Montage der Anpressprofile	44
11. Einschneiden des Entwässerungslappens	54
12. Zuschnitt und Montage Abdeckprofile	55
13. Demontage der Abdeckprofile	57
14. Zuschnitt und Montage flaches Deckprofil	58

**Procedure: Processing and assembly**

	Page
1. Overview: Construction	10
2. Positioning and assembly insulating studs	14
3. Positioning and assembly glazing supports	19
4. Cutting / assembly / notching the vertical internal gasket	23
5. Cutting and notching the horizontal internal gasket	27
6. Assembly horizontal internal gasket	30
7. Montage du support et de la cale de vitrage	38
8. Glass edge cover	40
9. Inserting infill units	41
10. Cutting and installation of clamping sections	44
11. Cutting the draining lip to size	54
12. Cutting and assembly the cover sections	55
13. Dismantling the cover sections	57
14. Cutting and assembly flat cover cap	58

**Séquences: Usinage et montage**

	Page
1. Aperçu de la construction	10
2. Disposition et montage boutons d'isolations	14
3. Disposition et montage supports de verre	19
4. Découpe / montage / entaille de joint intérieur vertical	23
5. Découpe et entaille de joint intérieur horizontal	27
6. Montage joint intérieur horizontal	30
7. Installation of glass support and glazing block	38
8. Prise en feuillure	40
9. Montage des éléments de remplissage	41
10. Découpe et montage des profilés de fixation	44
11. Découpe de la lèvre de drainage	54
12. Découpe et montage des profilés de recouvrement	55
13. Démontage des profilés de recouvrement	57
14. Découpe et montage profilé de recouvrement plat	58

**Sequenza di lavorazione e montaggio**

	Pagina
1. Panoramica metodo di montaggio	10
2. Disposizione e montaggio botoni d'isolamento	14
3. Disposizione e montaggio supporto vetri	19
4. Taglio / montaggio / intaglio delle guarnizioni interna verticale	23
5. Taglio e intaglio delle guarnizioni interna orizzontale	27
6. Montaggio guarnizione interna orizzontale	30
7. Montaggio del supporto vetro e dello spessore vetro	38
8. Posizionamento del vetro	40
9. Montaggio degli elementi di riempimento	41
10. Taglio e montaggio dei profili di fissaggio	44
11. Taglio della linguetta drenaggio	54
12. Taglio e montaggio delle copertine esterne	55
13. Demontaggio copertina esterna	57
14. Taglio e montaggio copertina esterna piatta	58

**1. Übersicht Bauweise**

**1. Aperçu de la construction**

- 1.1 Universal T-Verbinder
- 1.1 Raccord en T universel

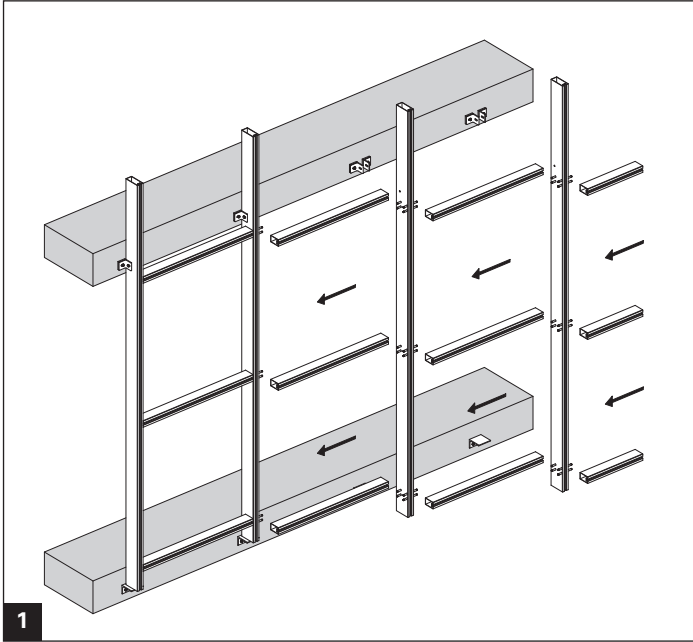

Steckbauweise  
 Méthode de construction modulaire  
 Push fit construction  
 Costruzione modulare

**1. Overview: Construction**

**1. Panoramica metodo di montaggio**

- 1.1 Universal connecting spigot
- 1.1 Raccordo a T universale

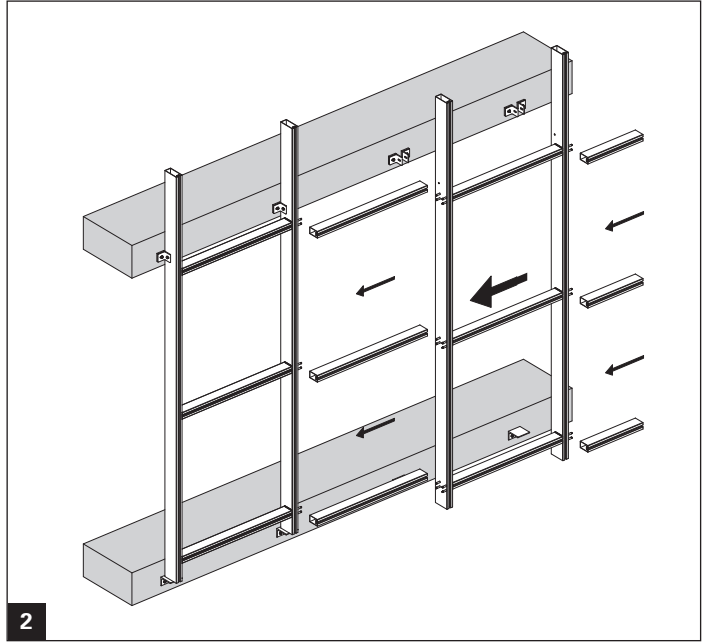

Kombination Rahmenbauweise / Steckbauweise  
 Construction par élément / méthode de construction modulaire  
 Element construction / Push fit construction  
 Costruzione ad elementi / costruzione modulare

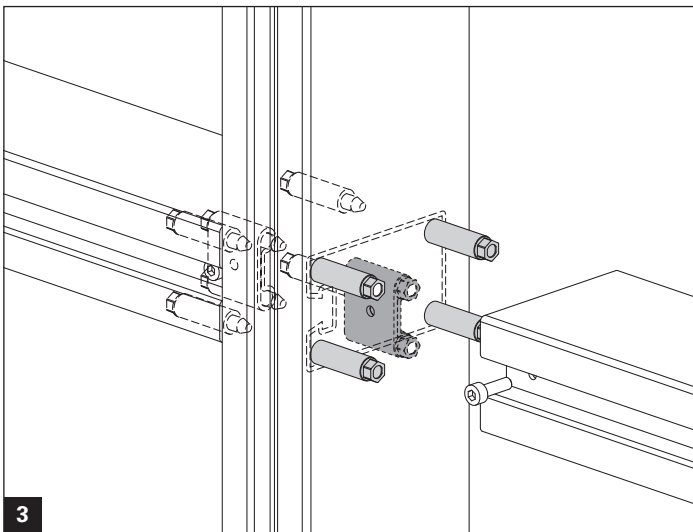

Riegel lose gesteckt / Riegelbefestigung optional  
 Traverse fichée sans fixation / fixation de la traverse optionnelle  
 Transom loose connection/transom fixing optional  
 Traverso innestato senza fissare / fissaggio opzionale



Hinweise Universal T-Verbinder siehe  
 «VISS Tragkonstruktion - Verarbeitung und  
 Montage»

Consignes raccords en T universel voir  
 «Construction porteuse VISS - Usinage et montage»

For information on universal connecting spigots  
 see «VISS supporting structure - Processing and  
 assembly»

Per le indicazioni riguardanti il raccordo a T  
 universale vedi «Struttura portante VISS -  
 Lavorazione e montaggio»



1.2 Schwerlast T-Verbinder einhängbar  
 1.2 Raccord en T charge lourde

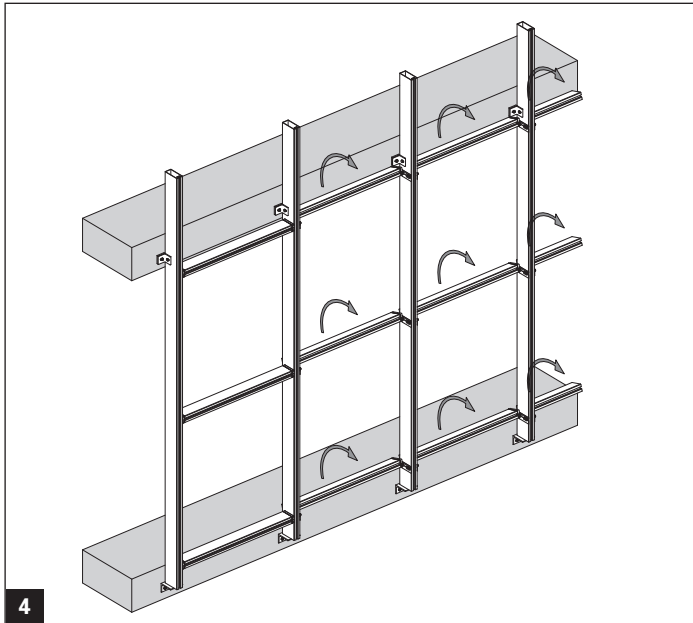

Steckbauweise  
 Méthode de construction modulaire  
 Push-fit construction system  
 Costruzione modulare

1.2 Heavy-duty connecting spigot  
 1.2 Raccordo a T ad incastro per carichi elevati

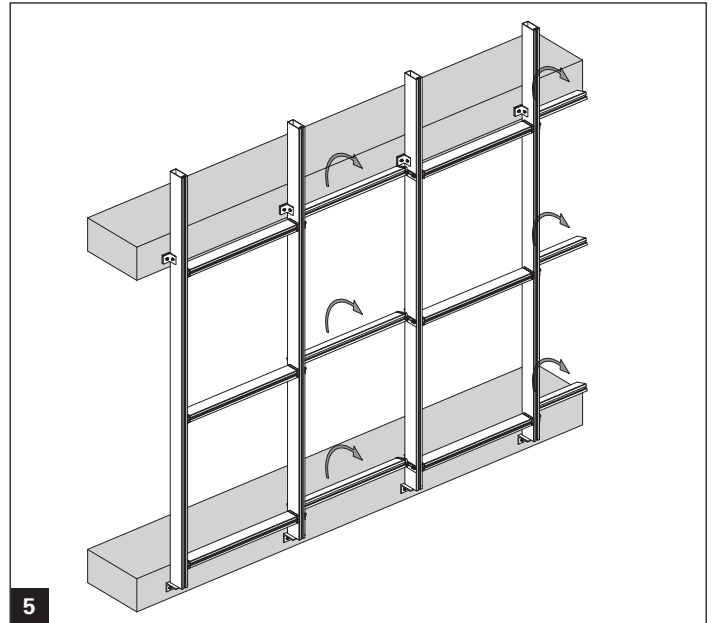

Kombination Rahmenbauweise / Steckbauweise  
 Kombination construction par éléments / construction modulaire  
 Kombination element construction / Push-fit construction  
 Costruzione ad elementi / costruzione modulare

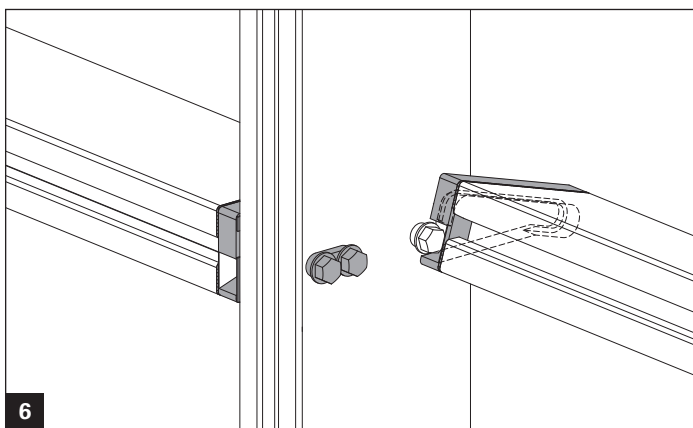

Einbausituation Schwerlast T-Verbinder  
 Situation de montage du raccord en T charge lourde  
 Installation location of heavy-duty connecting spigot  
 Montaggio del raccordo a T per carichi elevati



Hinweise Schwerlast T-Verbinder siehe  
 «VISS Tragkonstruktion - Verarbeitung und  
 Montage»

Consignes raccord en T charge lourde voir  
 «Construction porteuse VISS - usinage et montage»

For information on heavy-duty connecting spigots,  
 see «Fabrication and installation of VISS  
 supporting structure»

Per le indicazioni riguardanti il raccordo a T  
 ad incastro per carichi elevati vedi «Lavorazione e  
 montaggio struttura portante VISS»



1.3 T-Verbinder einhängbar  
1.3 Raccord en T à suspendre

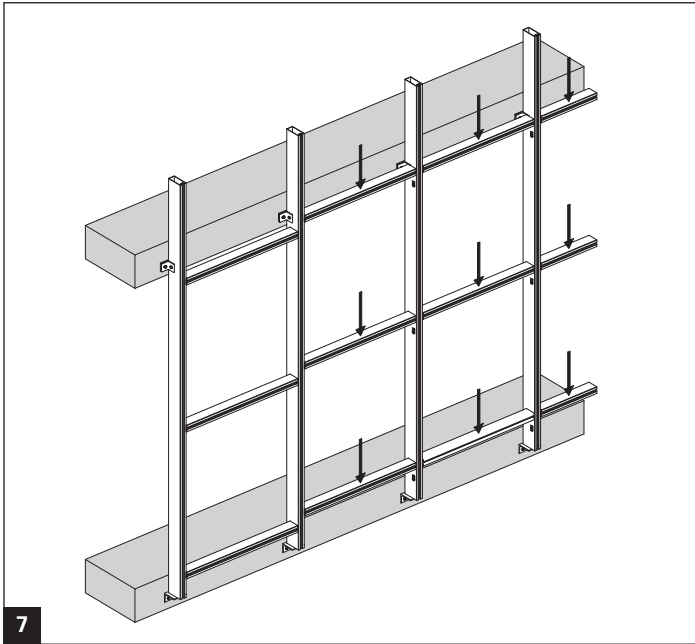

Steckbauweise  
Méthode de construction modulaire  
Push fit construction  
Costruzione modulare

1.3 Clip-in connecting spigots  
1.3 Raccordo a T ad incastro

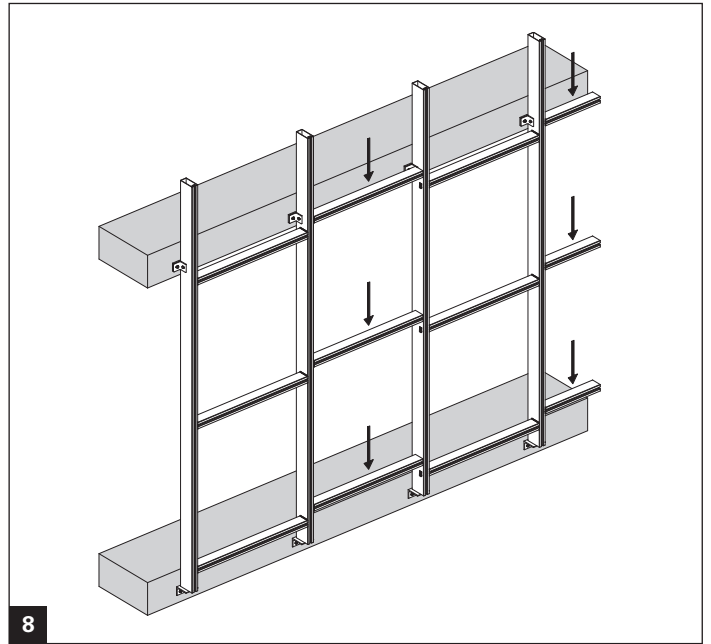

Kombination Rahmenbauweise / Steckbauweise  
Construction par élément / méthode de construction modulaire  
Element construction / Push fit construction  
Costruzione ad elementi / costruzione modulare

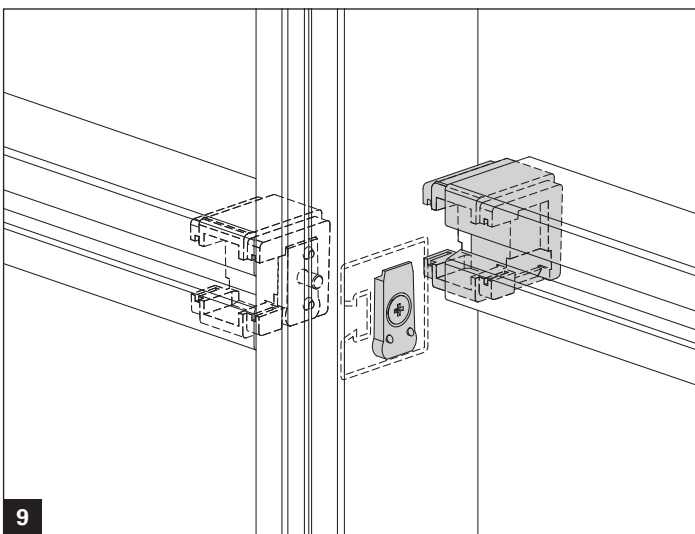

Hinweise einhängbare T-Verbinder siehe  
«VISS Tragkonstruktion - Verarbeitung und  
Montage»

Consignes raccords en T à suspendre voir  
«Construction porteuse VISS - Usinage et montage»

For information on clip-in connecting spigots see  
«VISS supporting structure - Processing and  
assembly»

Per le indicazioni riguardanti il raccordo a T ad  
incastro vedi «Struttura portante VISS -  
Lavorazione e montaggio»



1.4 Riegel geschweisst  
 1.4 Traverse soudé

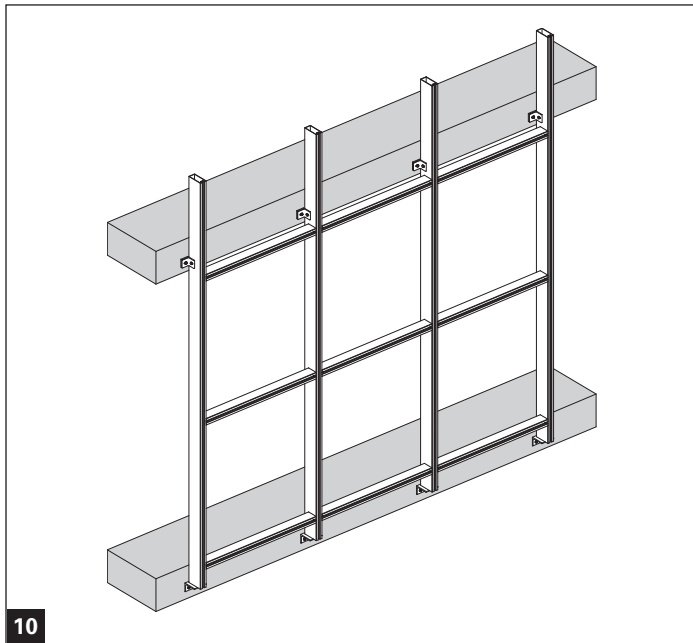

Rahmenbauweise  
 Construction par élément  
 Element construction  
 Costruzione ad elementi

1.4 Transom welding  
 1.4 Traverso saldati

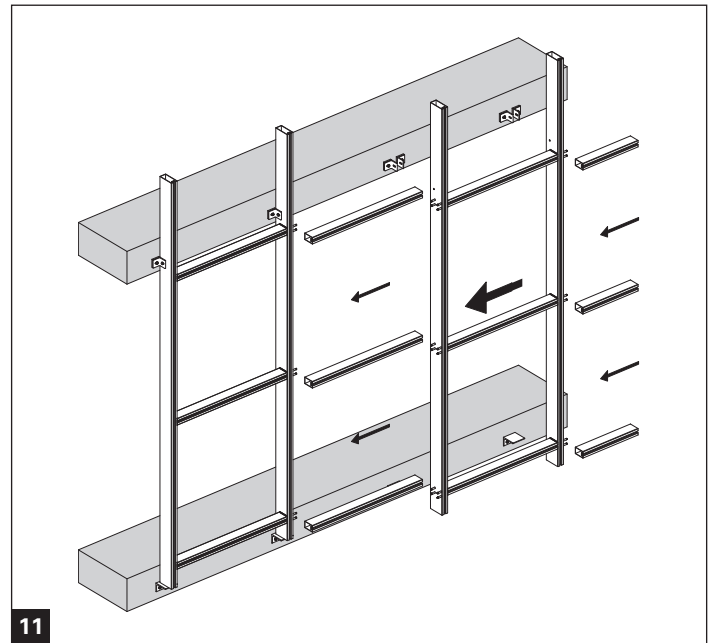

Kombination Rahmenbauweise / Steckbauweise  
 Construction par élément / méthode de construction modulaire  
 Element construction / Push fit construction  
 Costruzione ad elementi / costruzione modulare

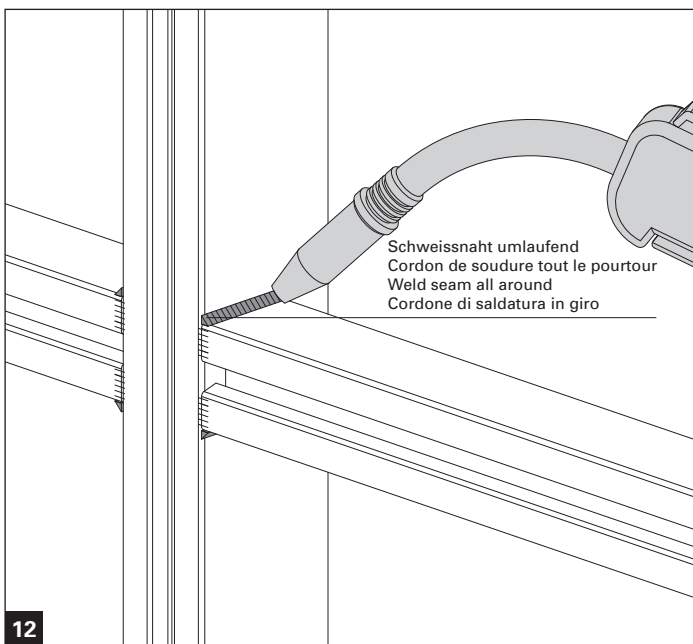

12



Hinweise Riegel geschweisst siehe  
 «VISS Tragkonstruktion - Verarbeitung und Montage»

Consignes traverses soudés voir  
 «Construction porteuse VISS - Usinage et montage»

For information on welded transoms see  
 «VISS supporting structure - Processing and assembly»

Per le indicazioni riguardanti il traverso saldato  
 vedi «Struttura portante VISS -  
 Lavorazione e montaggio»



**2. Anordnung und Montage Isolationsknöpfe**

**2. Disposition et montage boutons d'isolations**

**2. Positioning and assembly insulating studs**

**2. Disposizione e montaggio botoni d'isolamento**

2.1 Anordnung  
 2.1 Disposition

2.1 Positioning  
 2.1 Disposizione

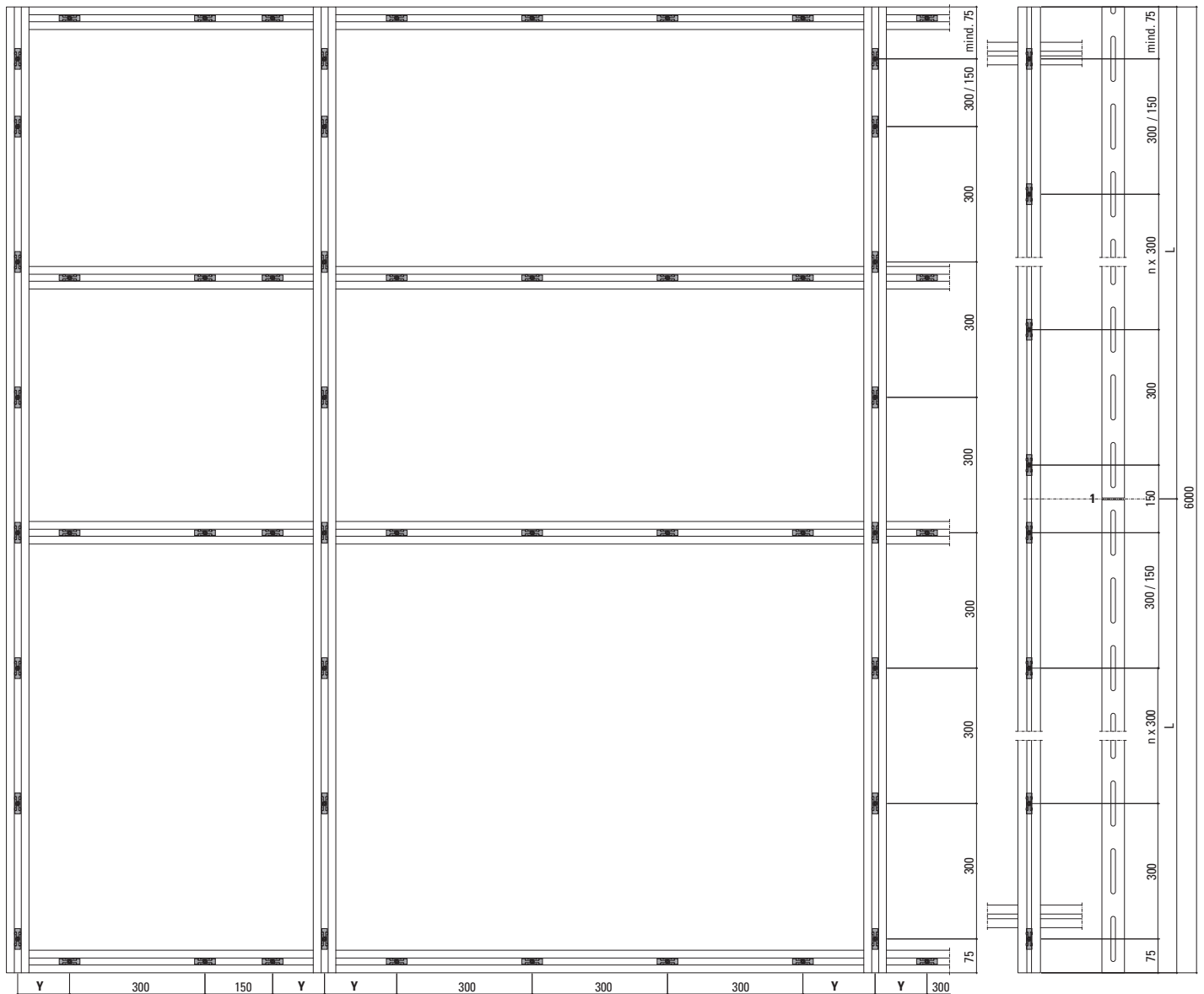

1) Die Position des Stosses des vertikalen Anpressprofils wird durch die Konstruktion / Metallbauer bestimmt.  
 Y) Der Randabstand wird durch den Pfostenabstand bestimmt (Mindestabstand 100 mm) / Berechnung Seite 16 ff.

1) La position de la jonction du profilé de fixation vertical est déterminée par la construction/le métallier.  
 Y) La distance au bord est déterminée par celle entre les montants (distance minimale 100 mm) /calcul pages 16 et suiv.

1) The position of the vertical pressure plate joint is determined by the designer/metal fabricator.  
 Y) The distance from the edge is determined by the distance between mullions (minimum distance 100 mm) / For calculation, see page 16 onwards

1) La posizione della giunzione del profilo di fissaggio verticale viene definita dalla struttura/dall'azienda di costruzioni metalliche.  
 Y) La distanza dal bordo dipende dalla distanza dal montante (valore minimo 100 mm) /calcolo a p. 16 e ss.



2.2 Positionierung Isolationsknopf im Pfostenbereich  
 2.2 Positionnement du bouton d'isolation dans la zone du montant

2.2 Positioning of insulating studs in the mullion area  
 2.2 Posizione del bottone isolante sul montante

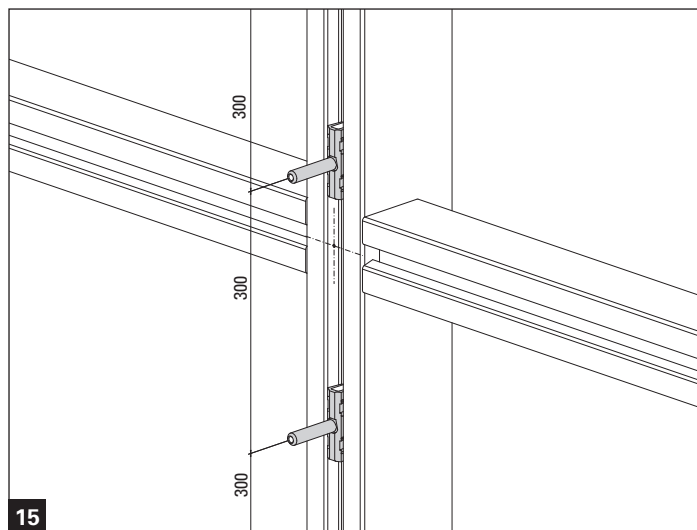
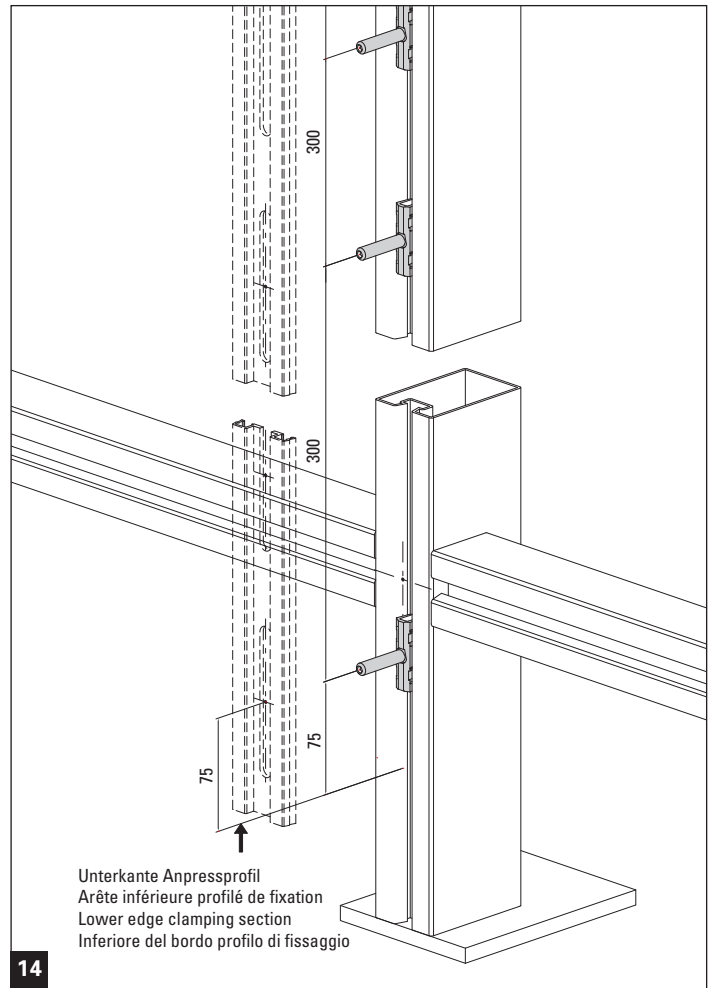
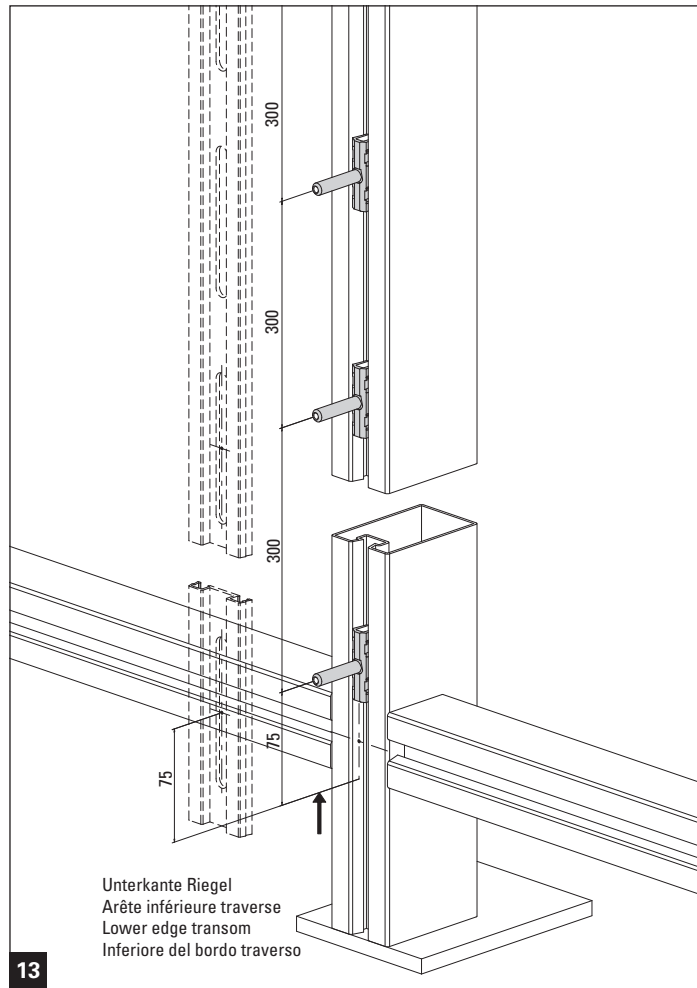

2.3 Positionierung Isolationsknopf im Riegelbereich  
2.3 Positionnement du bouton d'isolation dans la zone de la traverse

2.3 Positioning of insulating studs in the transom area  
2.3 Posizione del bottone isolante sul traverso

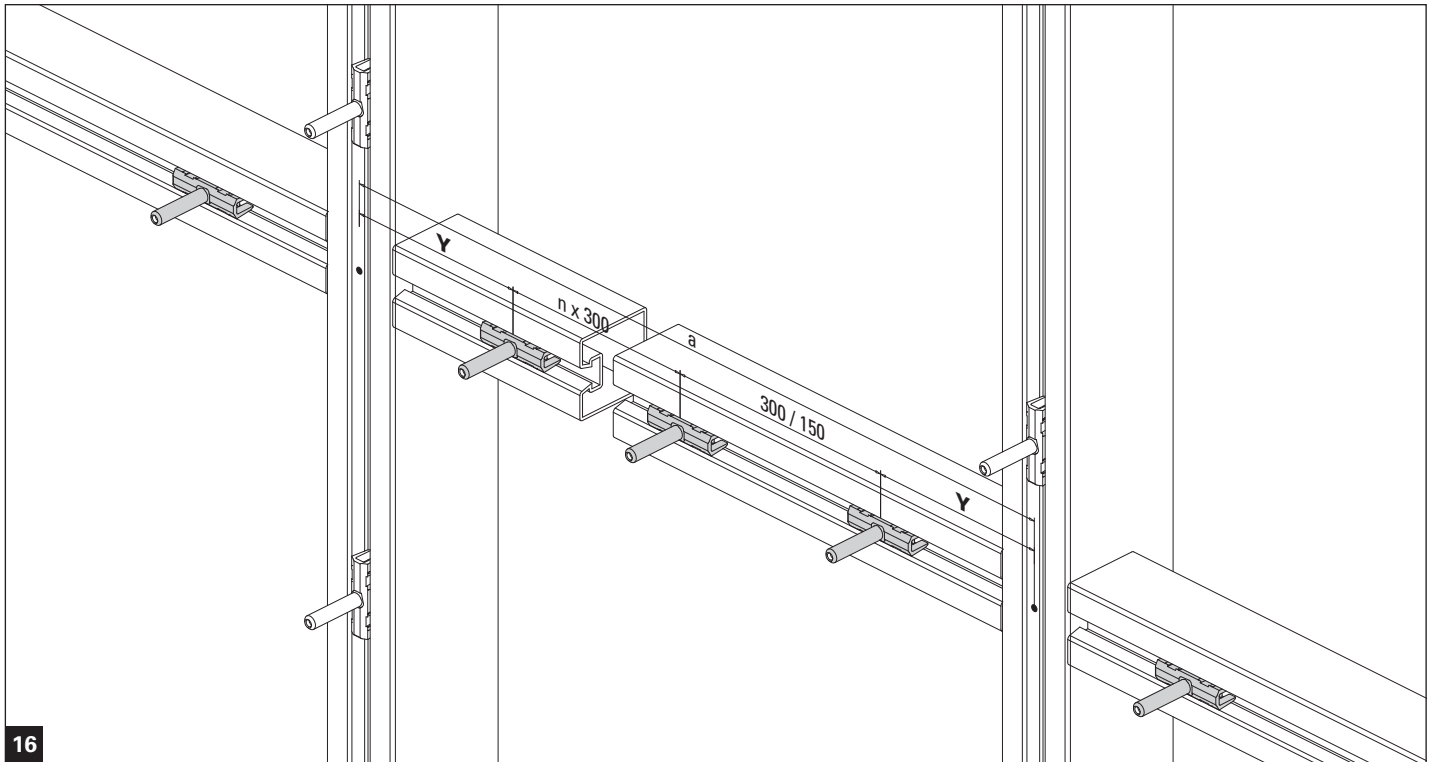

**Berechnung Randabstand y**

$(a - 200) / 150 = \text{Ergebnis}$   
Kommastelle von Ergebnis  $\times 75 + 100 = \text{Randabstand } y$

**Calcul distance périmétrique y**

$(a - 200) / 150 = \text{Résultat}$   
Virgule décimale du résultat  $\times 75 + 100 = \text{Distance périmétrique } y$

**Calculating the edge distance y**

$(a - 200) / 150 = \text{result}$   
Decimal place of result  $\times 75 + 100 = \text{Edge distance } y$

**Calcolo della distanza dal bordo y**

$(a - 200) / 150 = \text{Risultato}$   
Decimale del risultato  $\times 75 + 100 = \text{Distanza dal bordo } y$

a = Achsmass  
a = Entraxe  
a = Axis dimension  
a = Interasse

y = Randabstand  
y = Distance périmétrique  
y = Edge distance  
y = Distanza dal bordo

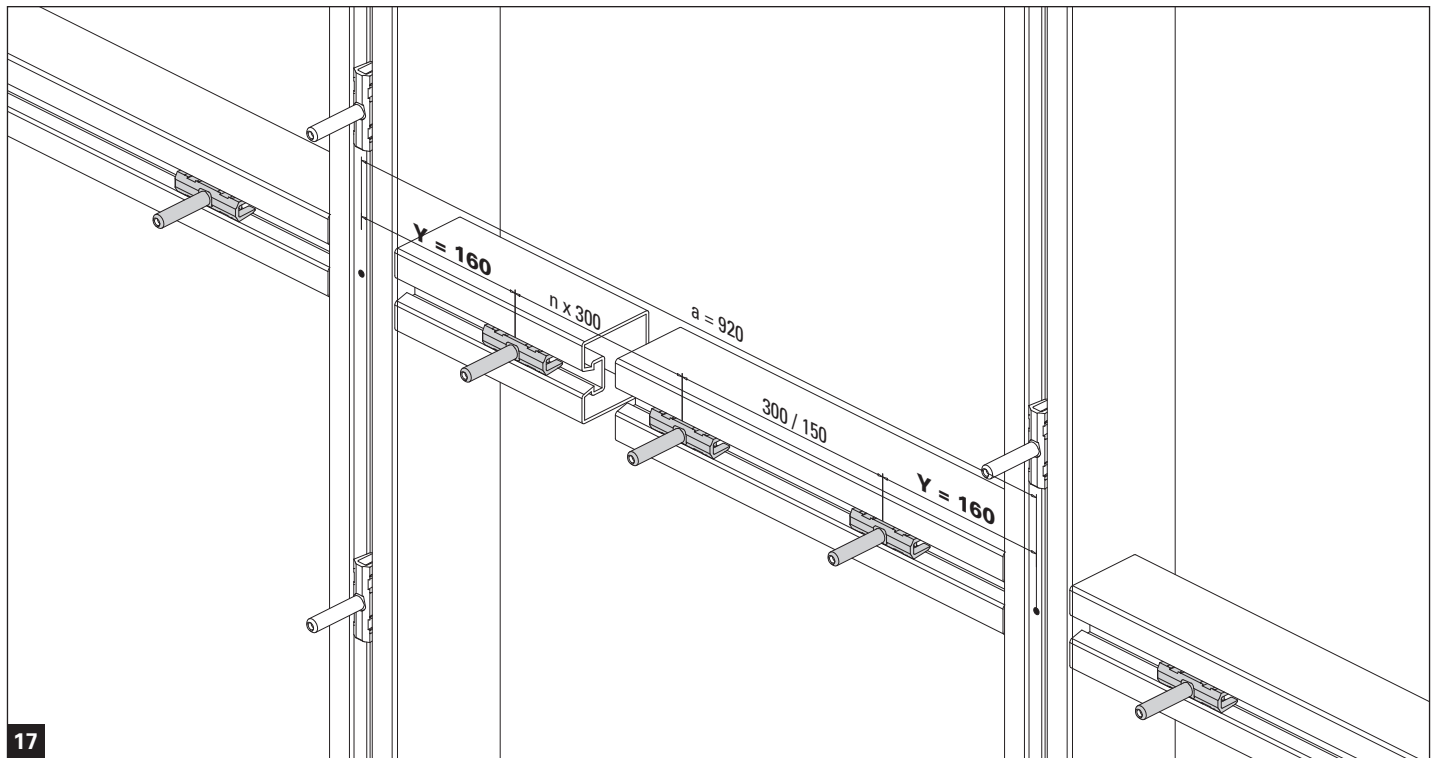

Beispiel / Exemple / Example / Esempio:  $y = (920 - 200) / 150 = 4,8$   
 $0,8 \times 75 + 100 = 160$

2.4 Montage Isolationsknöpfe  
2.4 Disposition boutons d'isolation

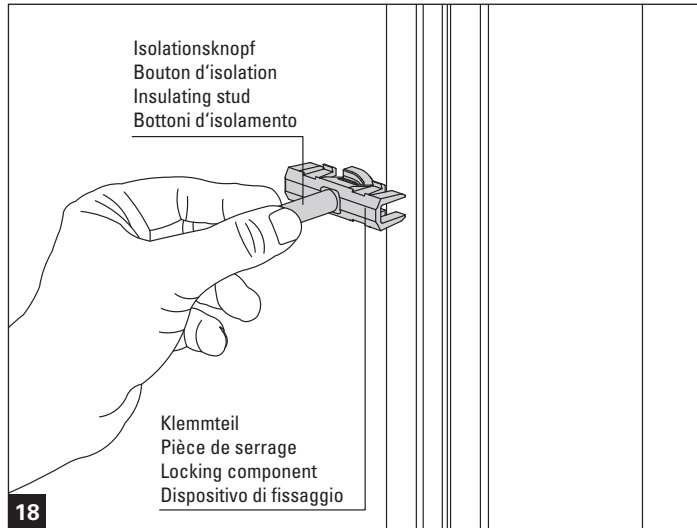

2.4 Installation of insulating studs  
2.4 Montaggio bottoni isolanti

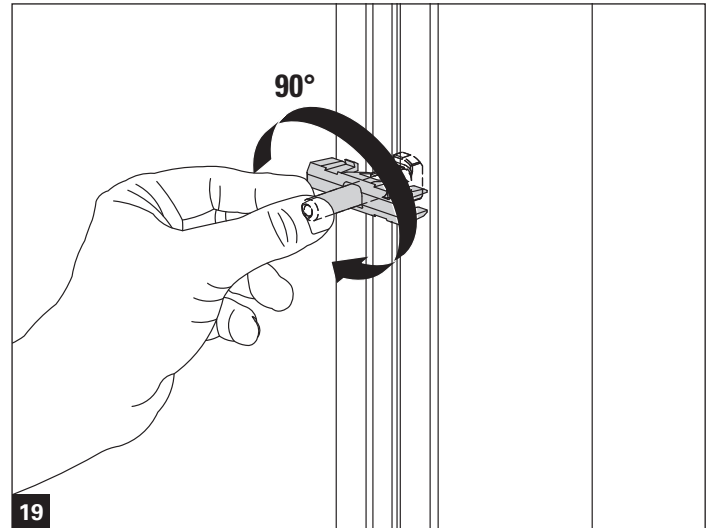

Isolationsknopf in Nute drücken und 90° drehen  
Presser le bouton d'isolation dans la rainure et tourner à 90°  
Insert insulating stud into groove and rotate 90°  
Premere il bottone isolante nella scanalatura , quindi ruotarlo di 90°

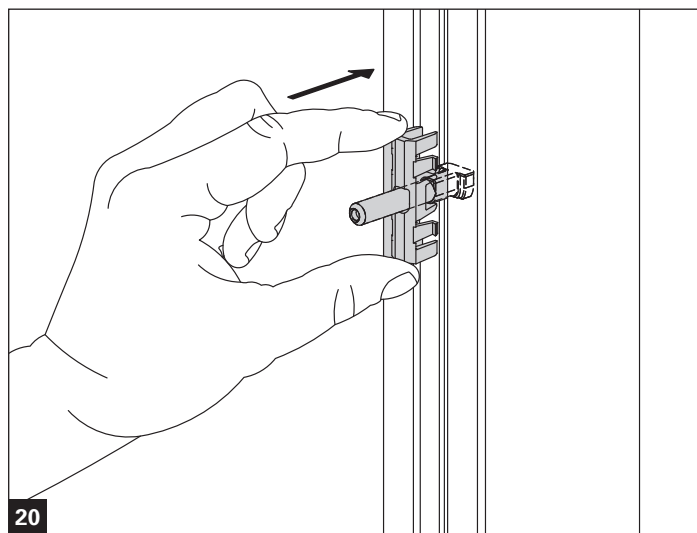

Klemmteil anschliessend in Nute drücken  
Presser ensuite la pièce de serrage dans la rainure  
Then insert locking component into groove  
Premere poi il dispositivo di fissaggio dentro la scanalatura

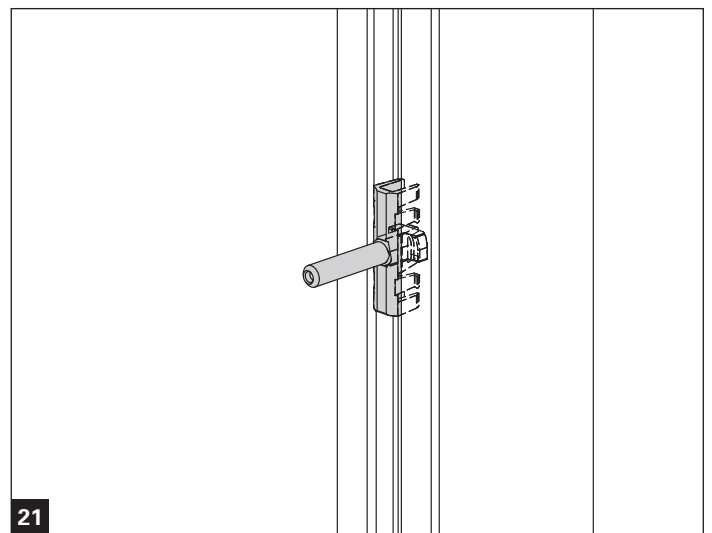

Isolationsknopf fertig montiert (Anker teil ist blockiert)  
Bouton d'isolation monté (l'ancre est bloquée)  
Installation of insulating stud complete (anchor component is blocked)  
Bottone isolante montato (ancoraggio bloccato)

**3. Anordnung und Montage Glasauflagen**

**3. Disposition et montage supports de verre**

- 3.1 Anordnung und Anzahl Glasauflagen
- 3.1 Disposition et nombre de supports de vitrage

**3. Positioning and assembly glazing supports**

**3. Disposizione e montaggio supporto vetri**

- 3.1 Positioning and quantity of glazing supports
- 3.1 Posizionamento e montaggio supporti vetro

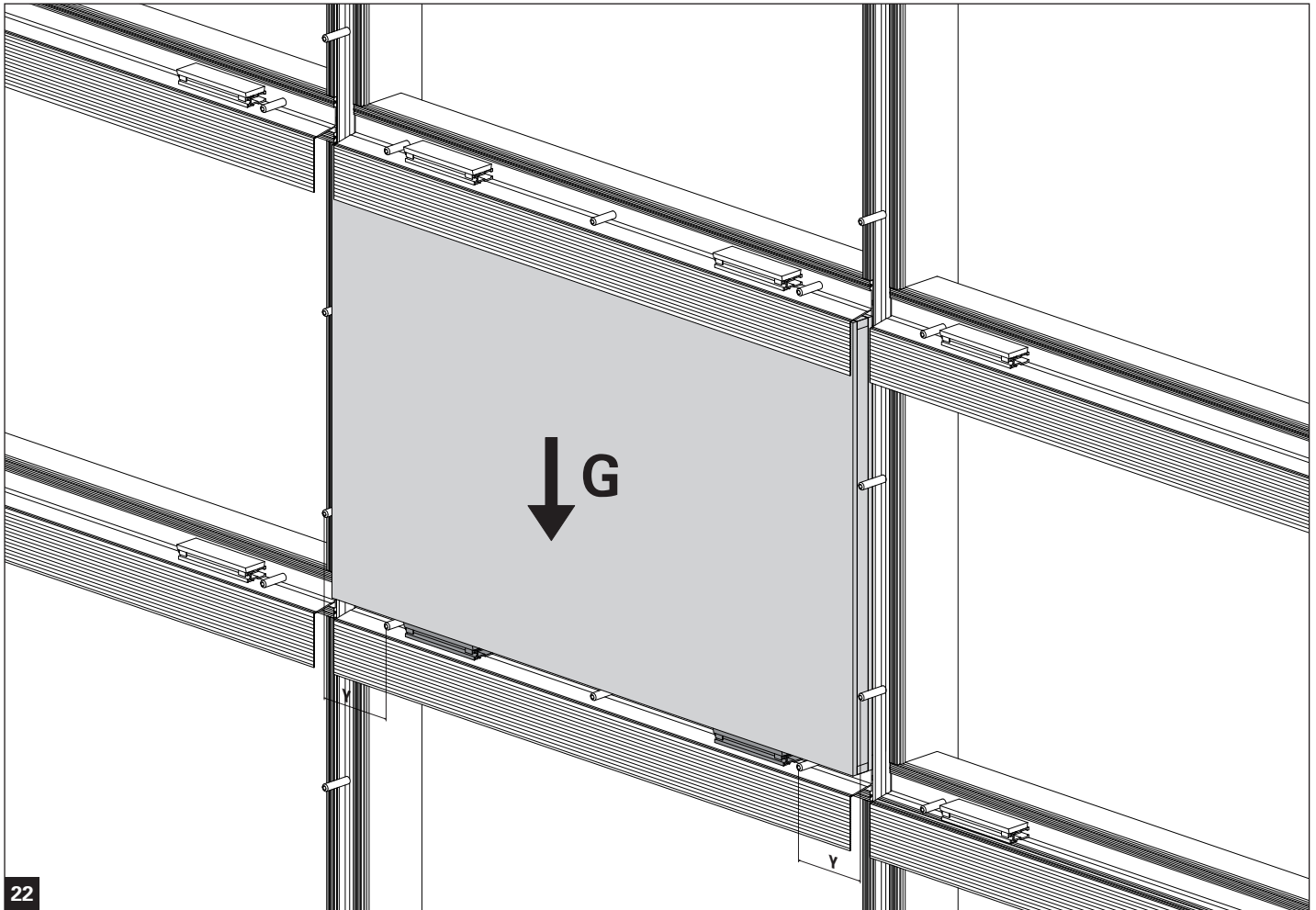

22

G = Gewicht Füllelement  
G = poids élément de remplissage

G = weight infill unit  
G = peso elemento di riempimento

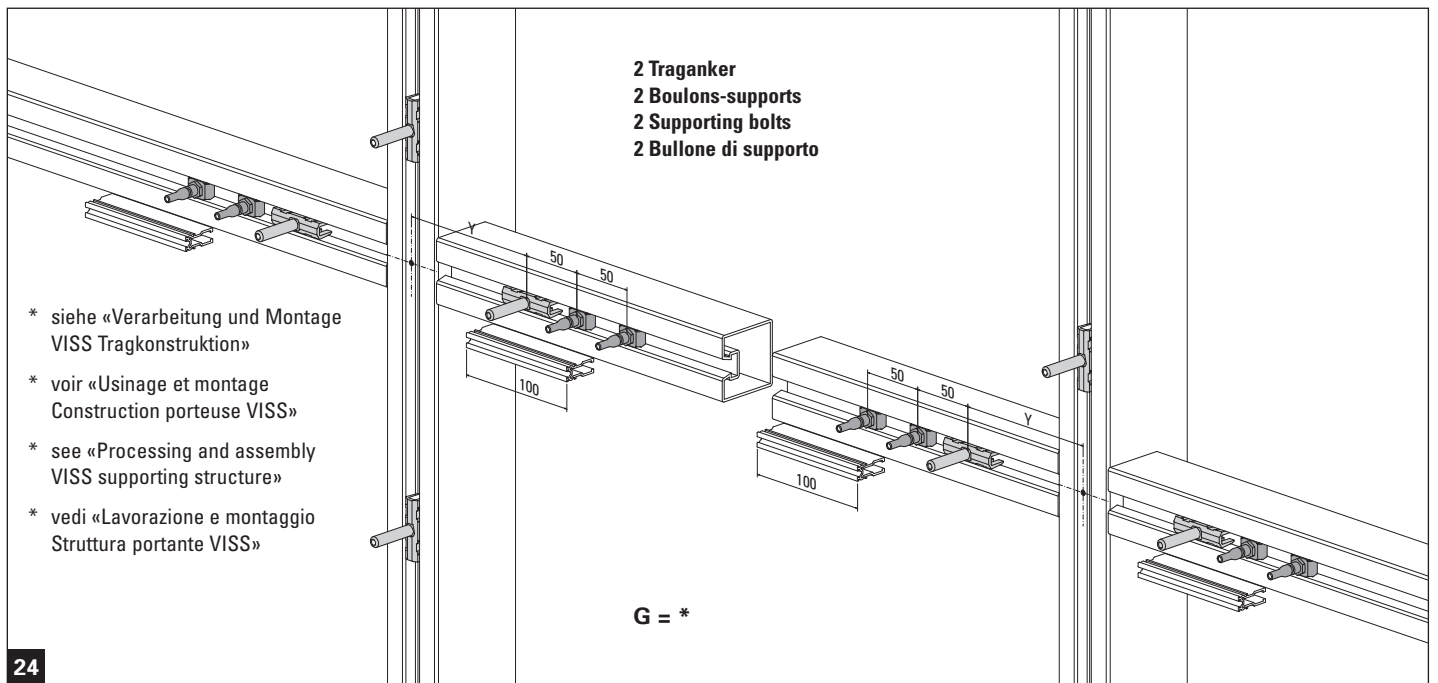
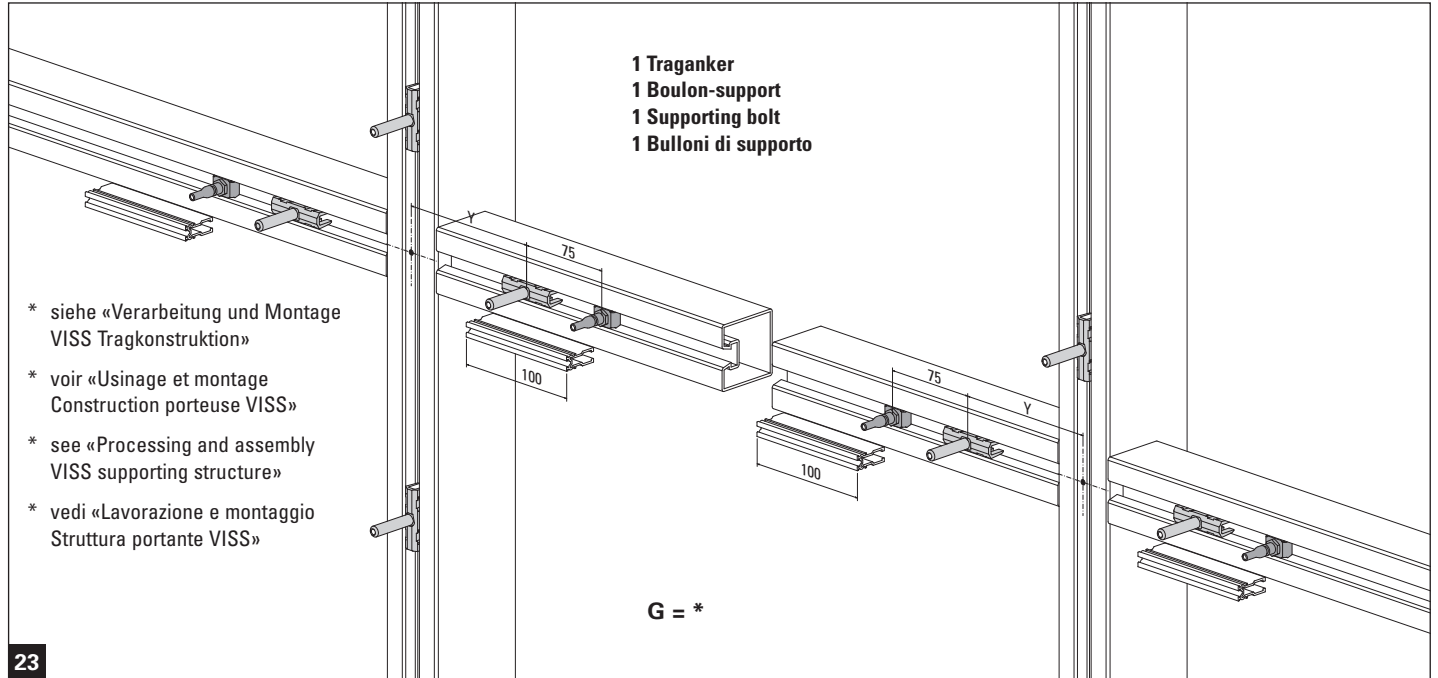

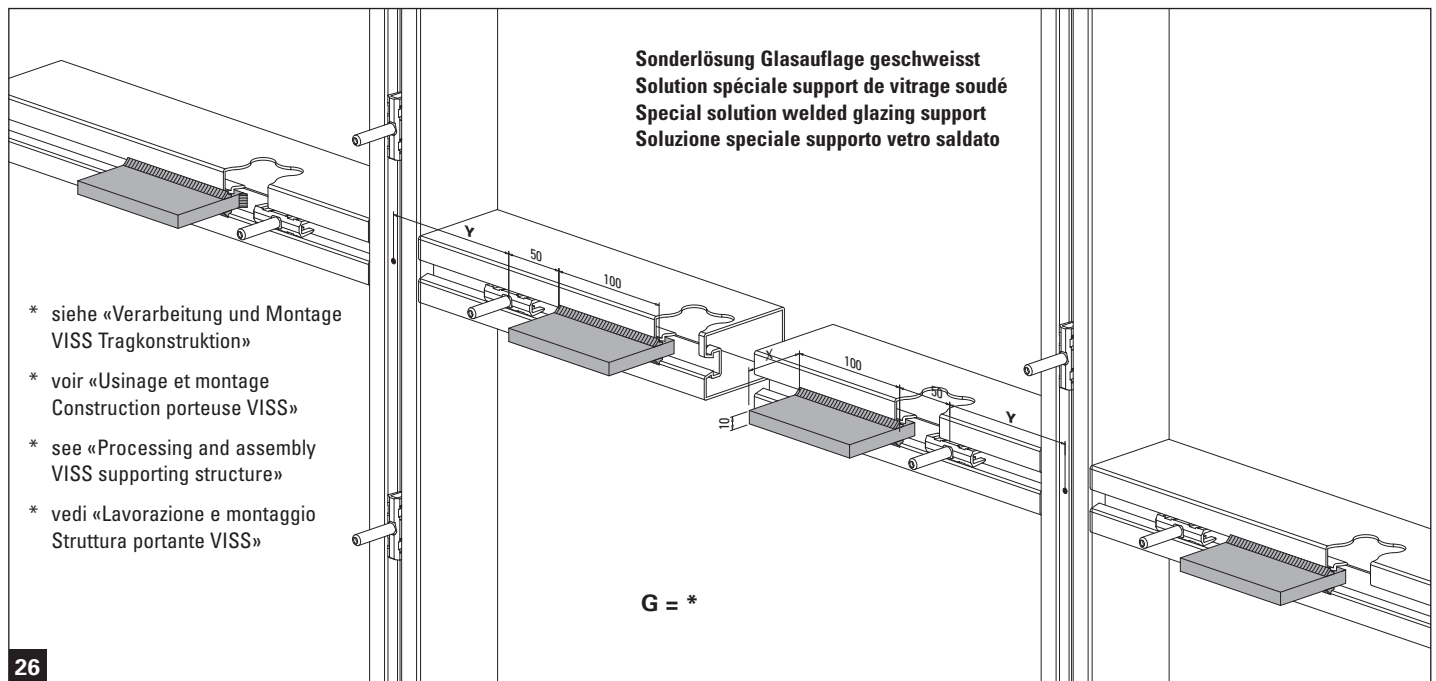
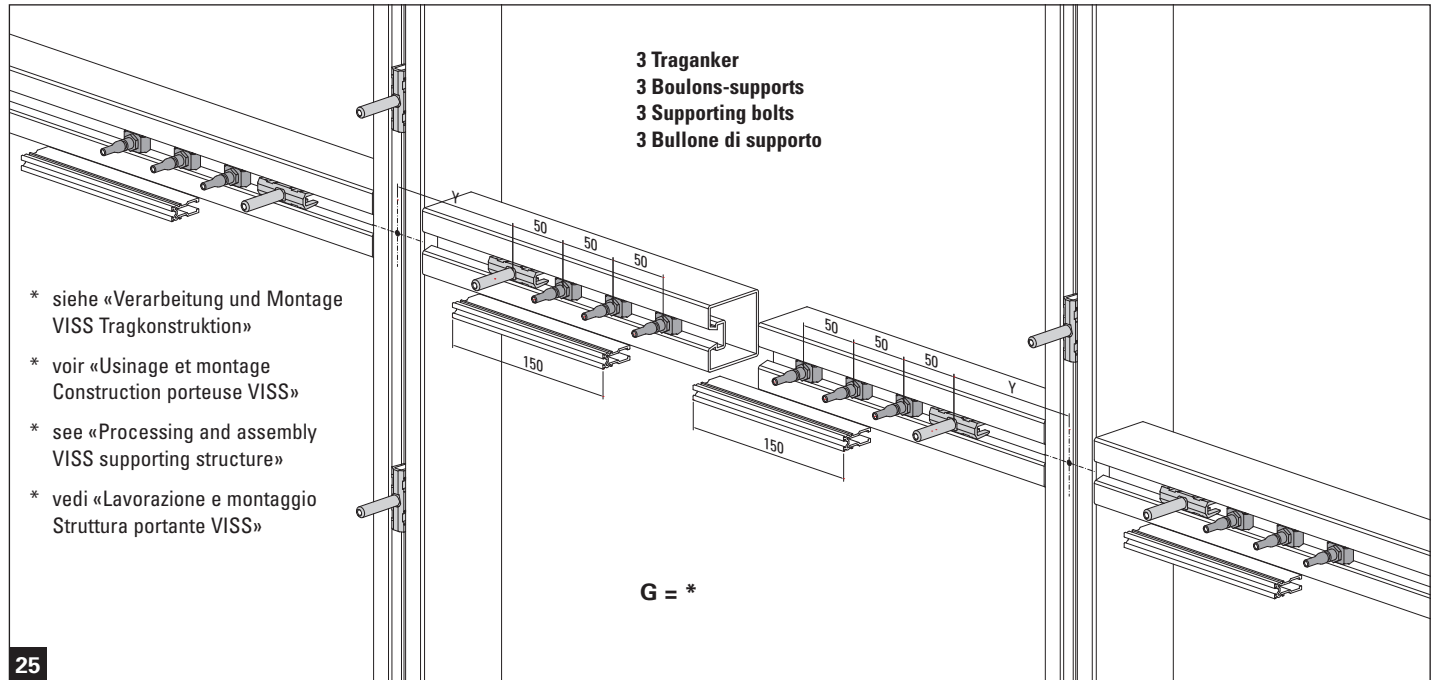

3.2 Montage Glasauflagen  
 3.2 Montage supports de verre

3.2 Assembly glazing supports  
 3.2 Montaggio supporto vetri

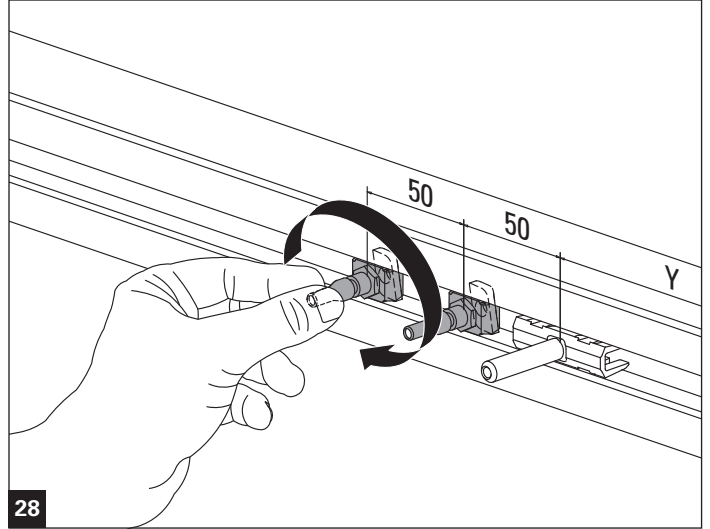
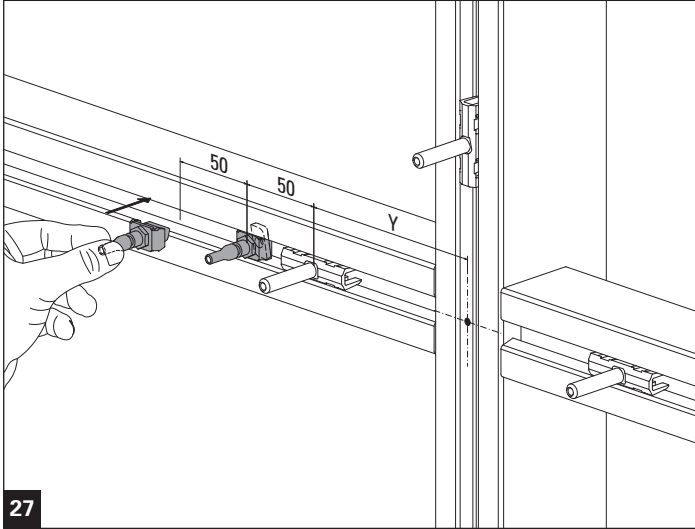

Traganker in Nute drücken und eindrehen  
 Presser le boulon-support dans la rainure et visser  
 Insert anchor bolts in groove and tighten  
 Premere il bullone di supporto nella scanalatura e ruotarlo

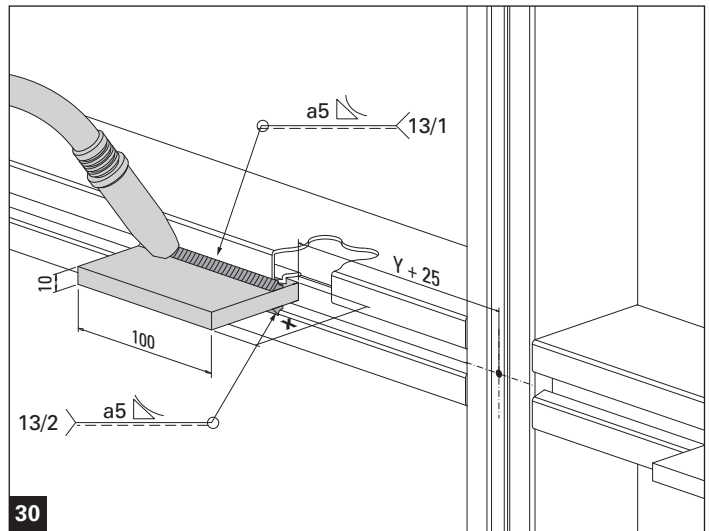
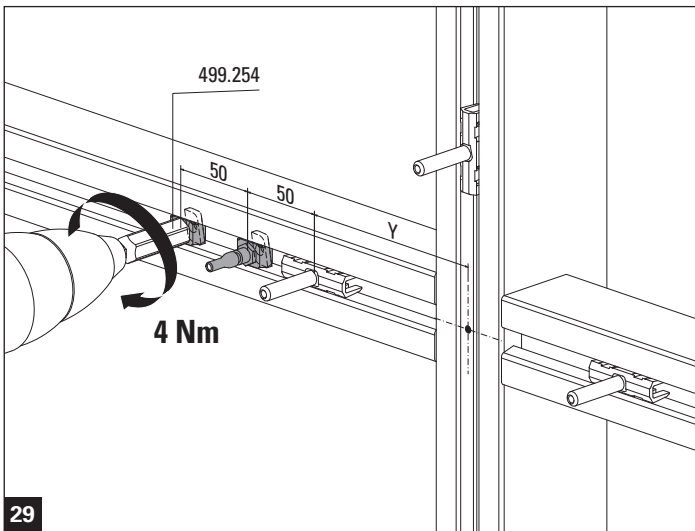

Traganker mit einem Drehmoment von 4 Nm anziehen  
 Serrer le boulon-support avec un couple de 4 Nm  
 Tighten anchor bolts with a torque of 4 Nm  
 Serrare il bullone di supporto con una coppia di 4 Nm

Variante Glasauflage geschweisst:  
 Stahlflach (min. S235) umlaufend anschweißen  
 X = Füllelementstärke + 25 mm  
 Variante support de vitrage soudé:  
 Acier plat (min. S235) soudé sur toute la périphérie  
 X = épaisseur de l'élément de remplissage + 25 mm  
 Option - welded glazing support:  
 Weld on steel flat (min. S235) all around  
 X = infill unit thickness + 25 mm

Variante supporto vetro saldato: saldare una piastrina di acciaio (min. S235) su tutto il proprio perimetro  
 X = spessore elemento di riempimento + 25 mm



**4. Zuschnitt / Montage / Ausklinkung Innendichtung vertikal**

**4. Découpe / montage / entaille de joint intérieur vertical**

**4. Cutting / assembly / notching the vertical internal gasket**

**4. Taglio/montaggio/intaglio delle guarnizione interna verticale**

4.1 Zuschnitt Innendichtung vertikal

4.1 Découpe du joint intérieur vertical

4.1 Cutting the vertical internal gasket

4.1 Taglio della guarnizione interna verticale

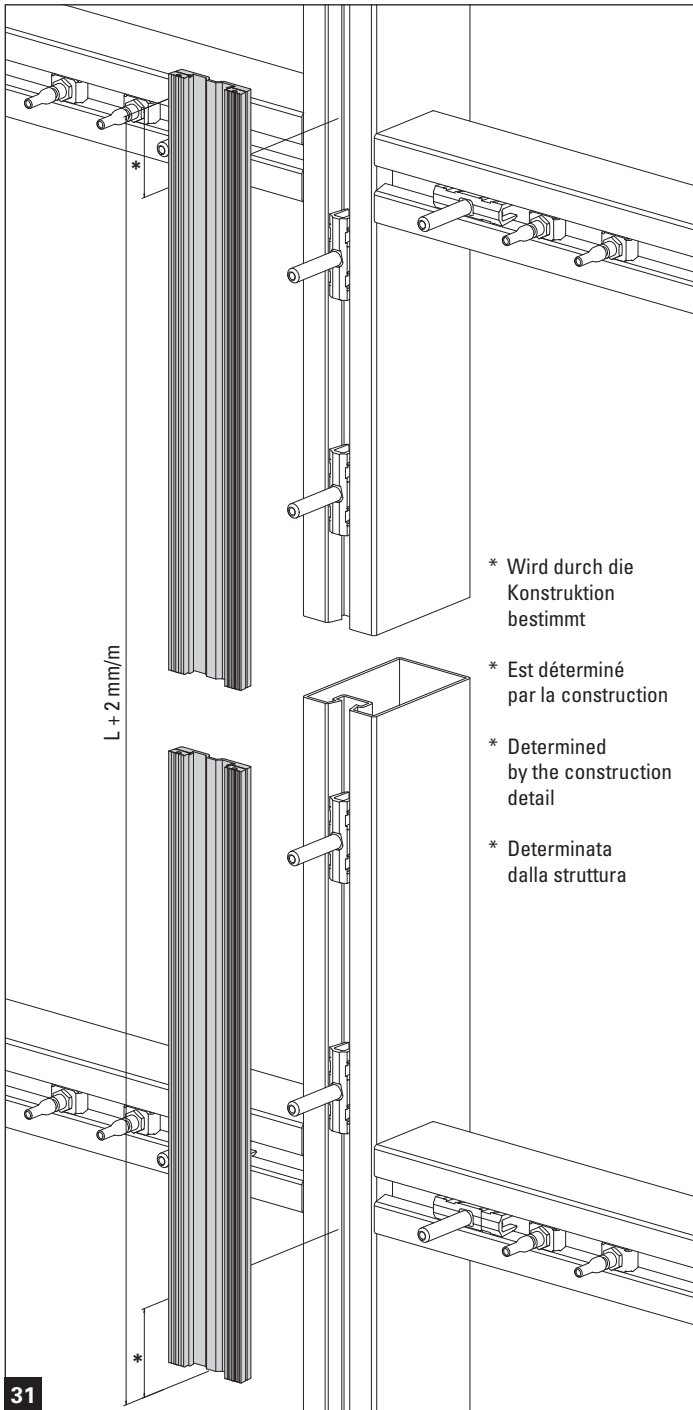

Längenzuschlag von 2 mm/m beachten

Tenir compte du supplément de longueur de 2 mm/m

Note length allowance of 2 mm/m

Considerare la maggiorazione in lunghezza di 2 mm/m

4.2 Montage Innendichtung vertikal  
 4.2 Montage du joint intérieur vertical

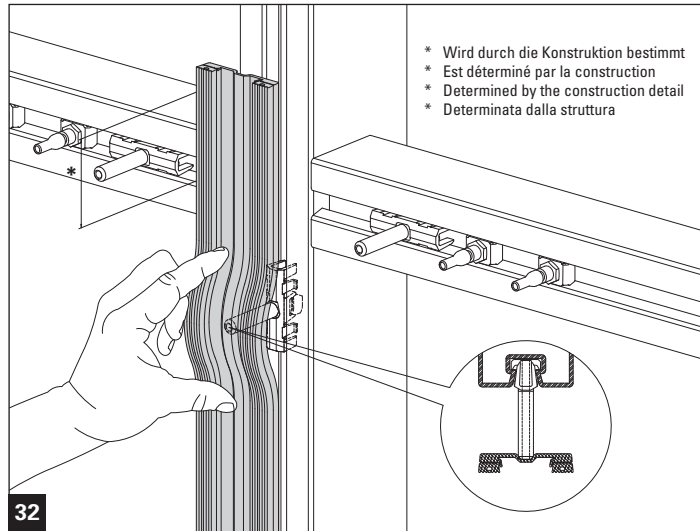

4.2 Assembly the vertical gasket  
 4.2 Montaggio della guarnizione interna verticale

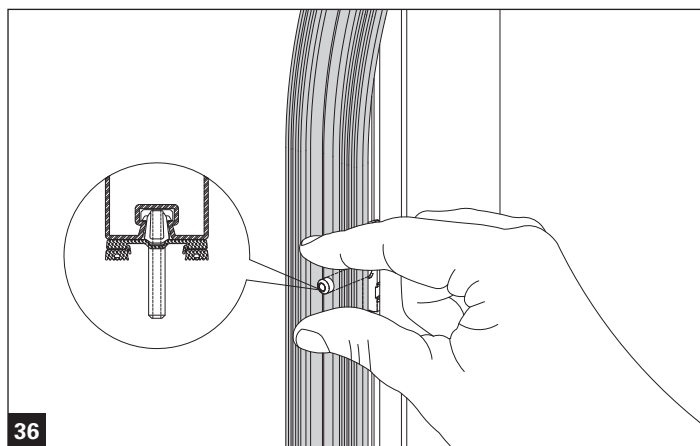
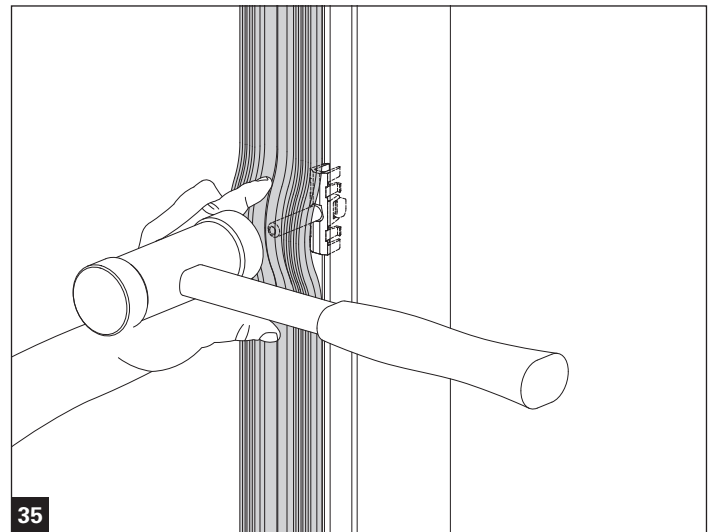
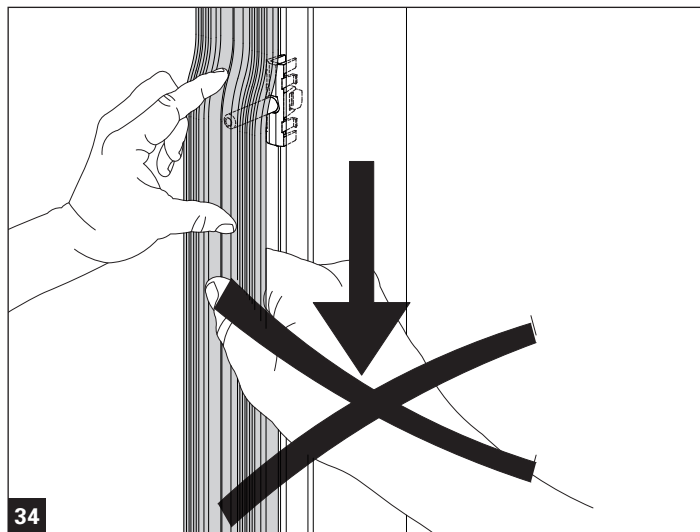
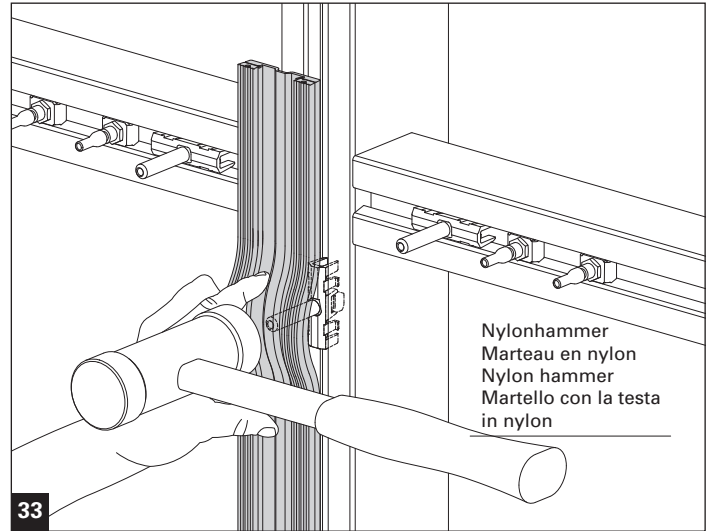

4.3 Ausklinkung Innendichtung vertikal Kreuzpunkt  
4.3 Entaille de joint intérieur vertical point d'intersection

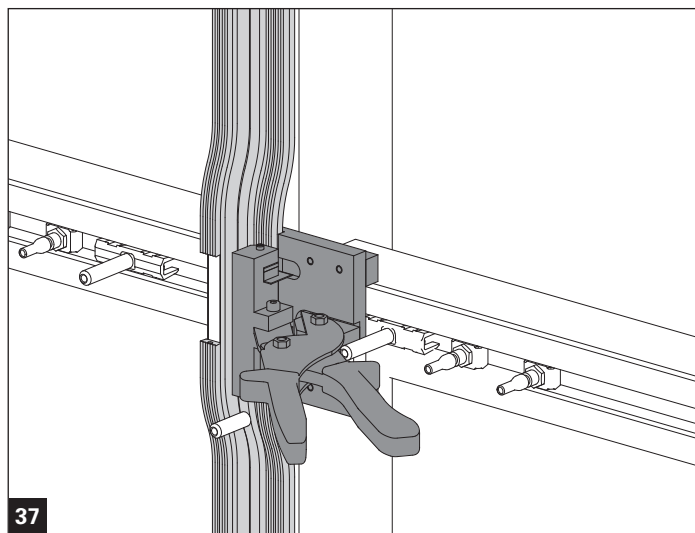

Ausklinkung mit Dichtungsstanze 499.266  
Entaille avec poinçon à joints 499.266  
Notching with gasket punch 499.266  
Intaglio della guarnizione con l'apposita punzonatrice 499.266

4.3 Notching the vertical weatherstrip intersection  
4.3 Intaglio della guarnizione interna verticale punto di intersezione

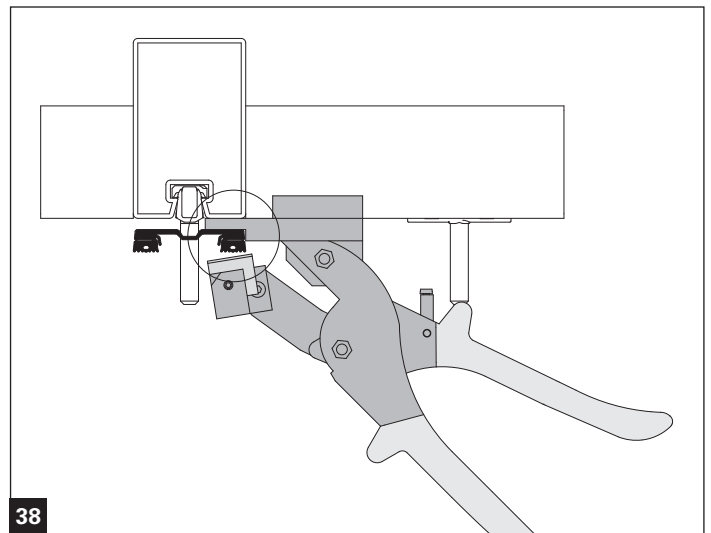

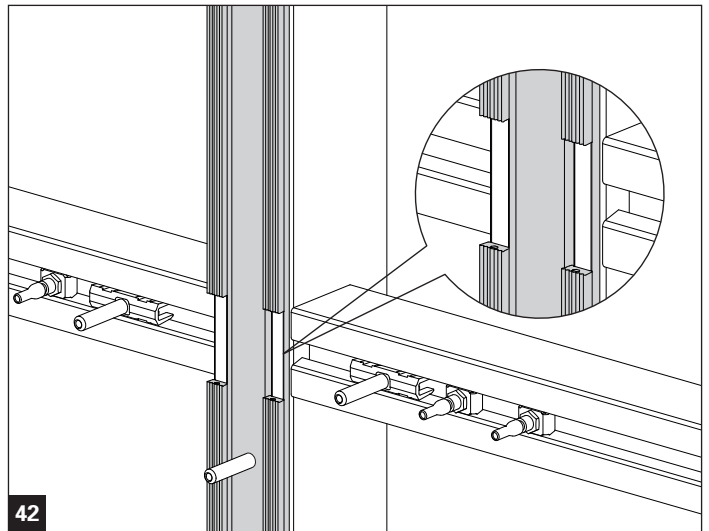
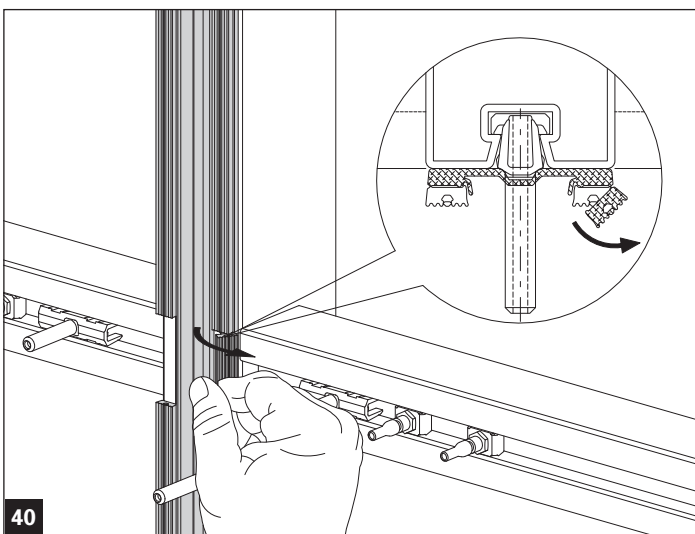
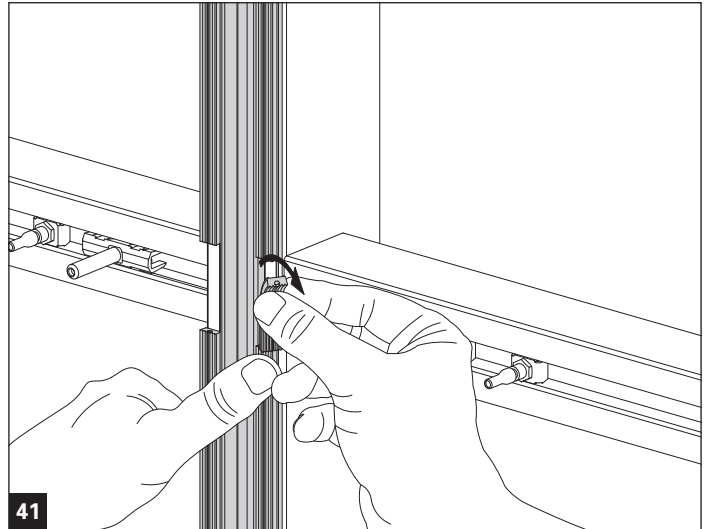
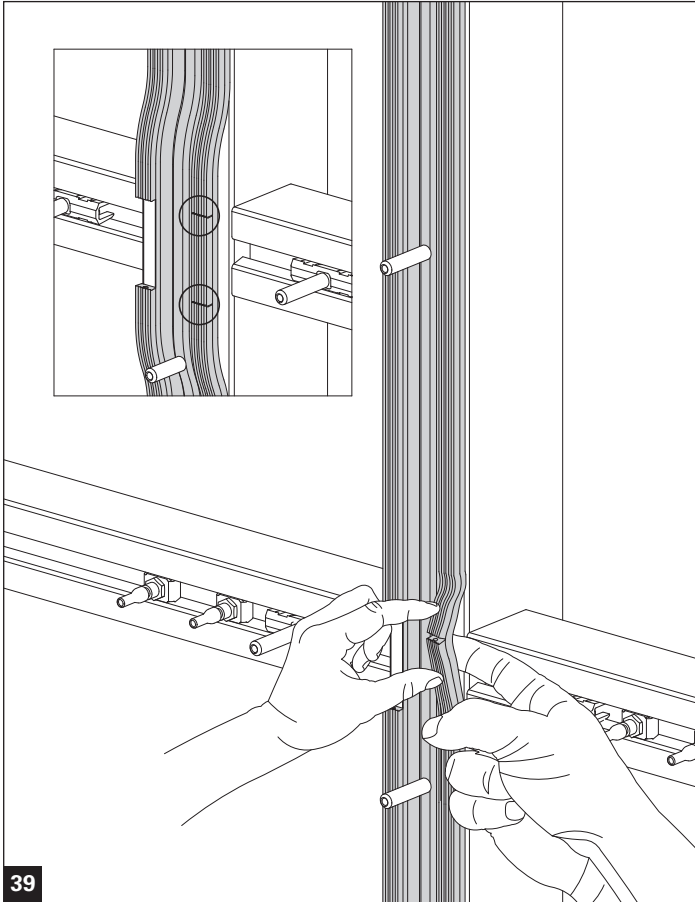

**5. Zuschnitt und Ausklinkung Innendichtung horizontal**

**5. Découpe et entaille de joint intérieur horizontal**

**5. Cutting and notching the horizontal internal gasket**

**5. Taglio e intaglio delle guarnizioni interna orizzontale**

5.1 Zuschnitt Innendichtung horizontal  
 5.1 Découpe du joint intérieur horizontale

5.1 Cutting the horizontal internal gasket  
 5.1 Taglio della guarnizione interna orizzontale

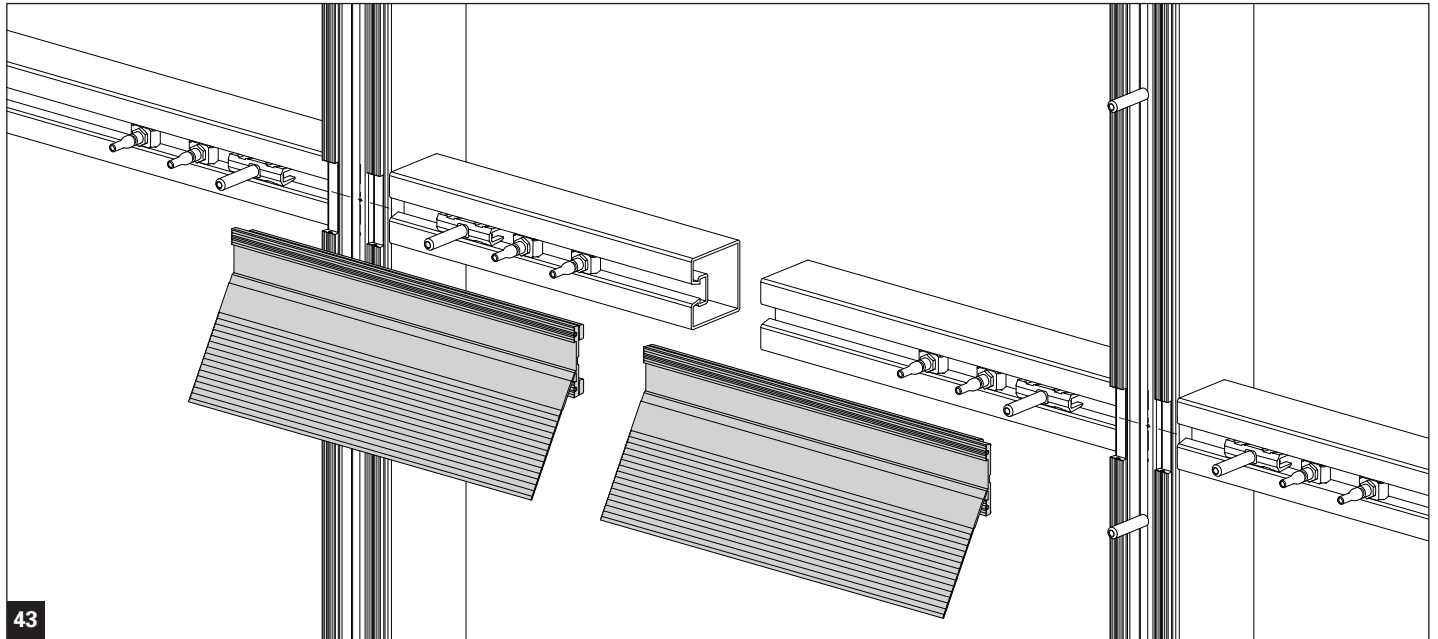

43

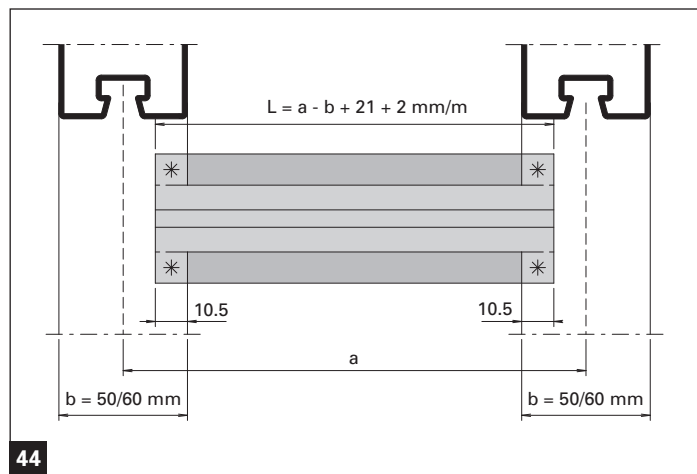

44

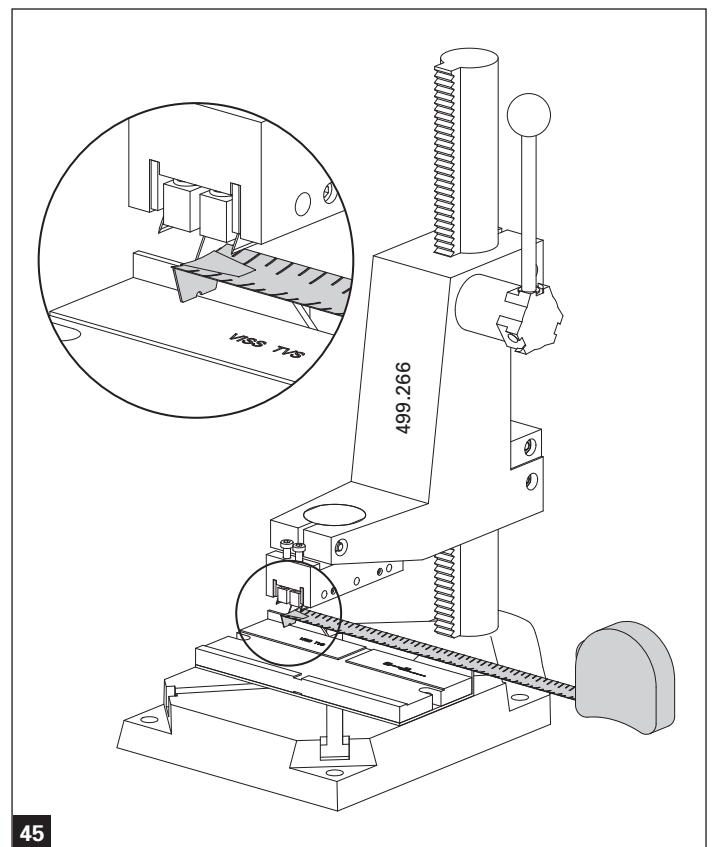

45

5.2 Ausklinkung Innendichtung horizontal  
5.2 Entaille de joint intérieur horizontal

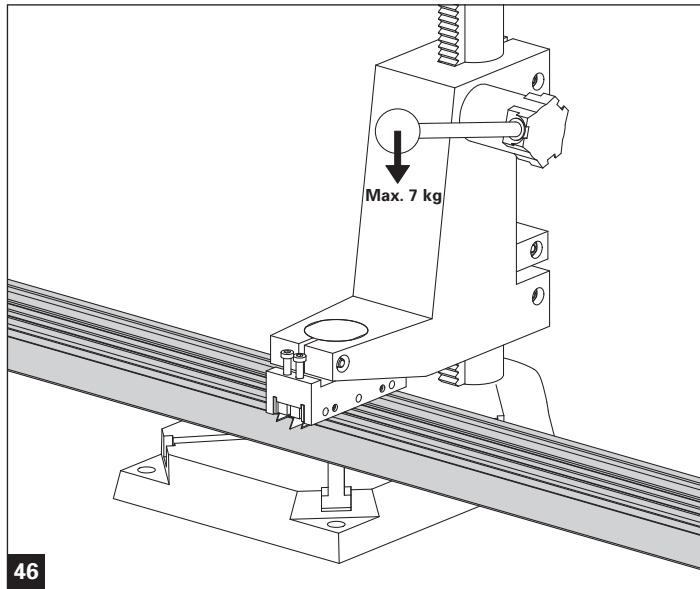

5.2 Notching the horizontal internal weatherstrip  
5.2 Intaglio della guarnizione interna orizzontale

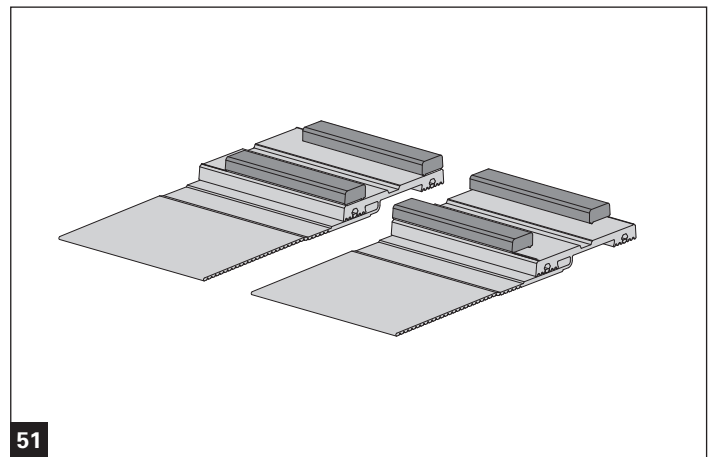
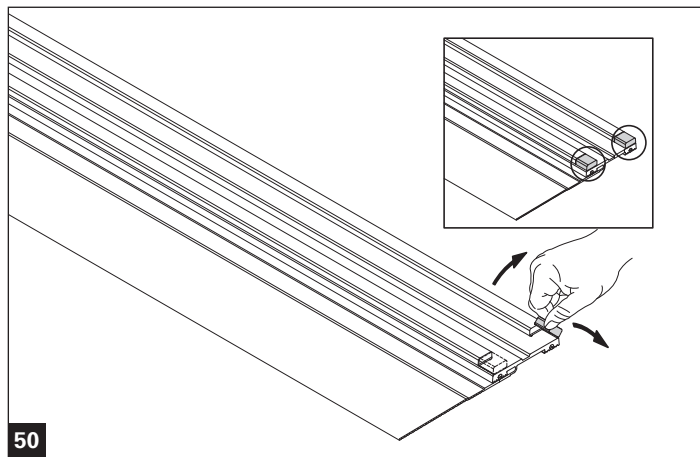
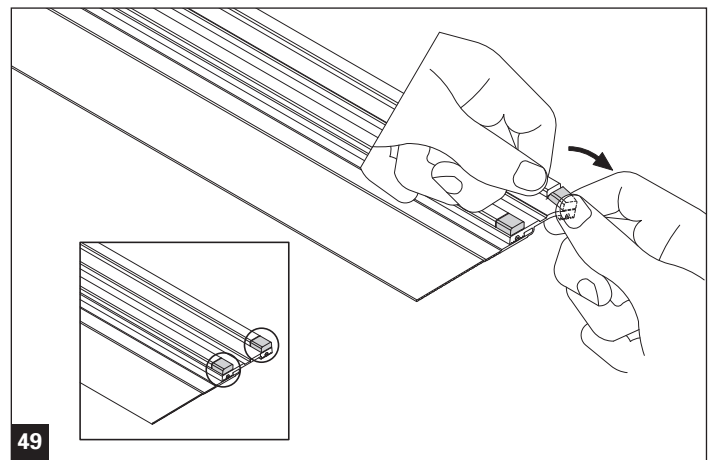
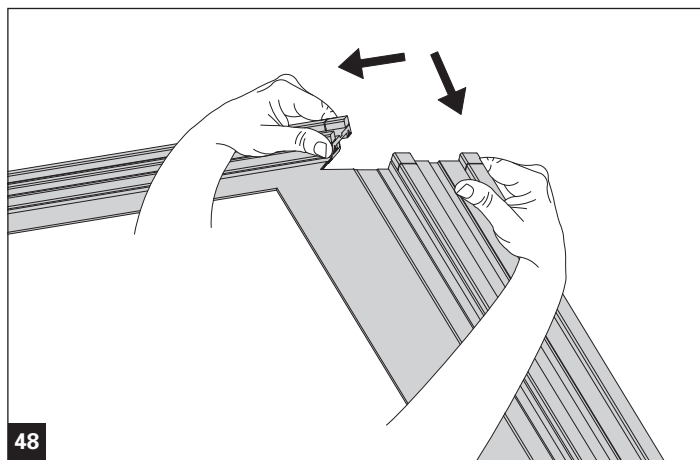
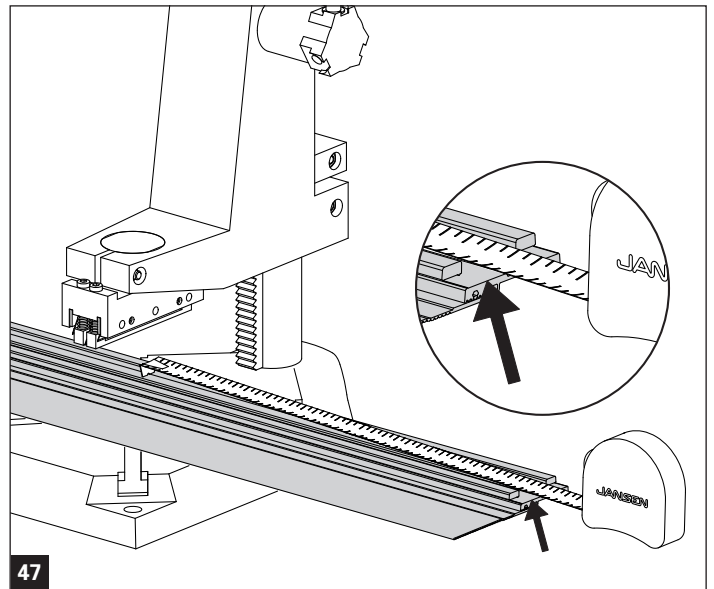

5.3 Aufbringung Butyl-Dichtstreifen  
5.3 Pose d'une bande d'étanchéité en butyle

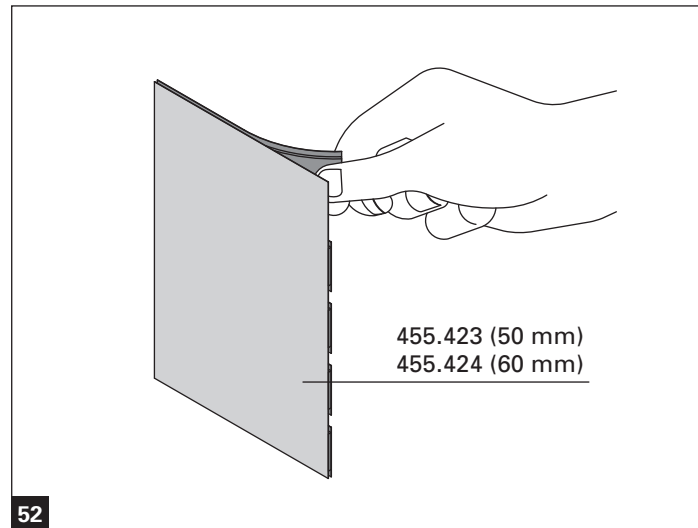

5.3 Application of the butyl sealing strips  
5.3 Applicazione della striscia di sigillante butilico

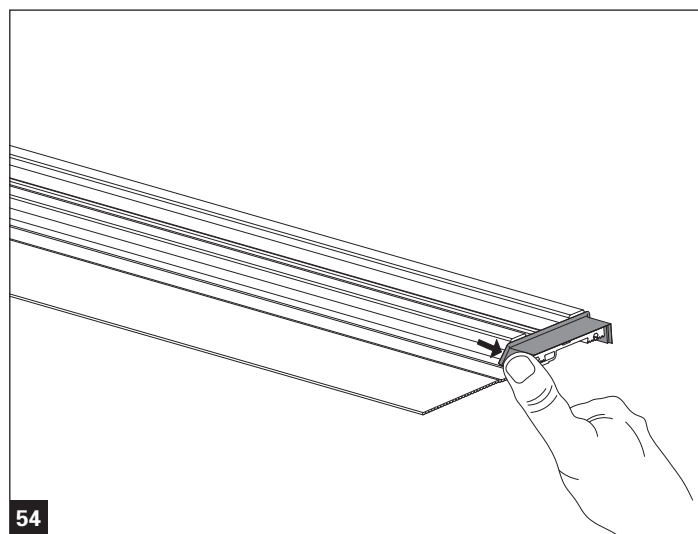
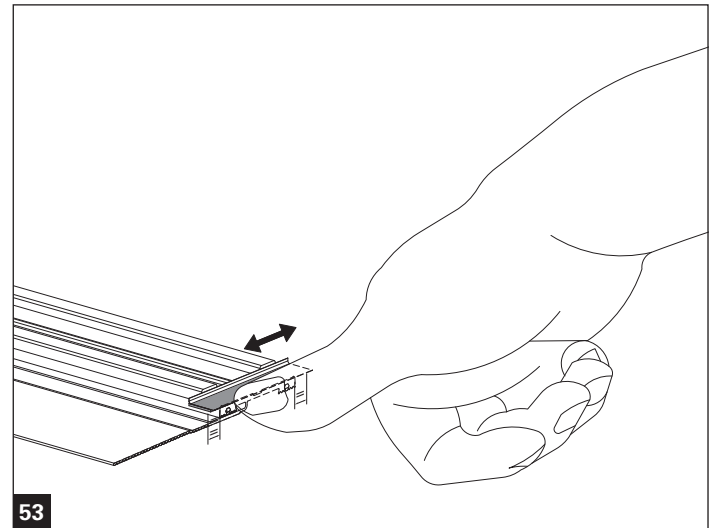

**6. Montage Innendichtung horizontal**

**6. Assembly horizontal internal gasket**

**6. Montage joint intérieur horizontal**

**6. Montaggio guarnizione interna orizzontale**

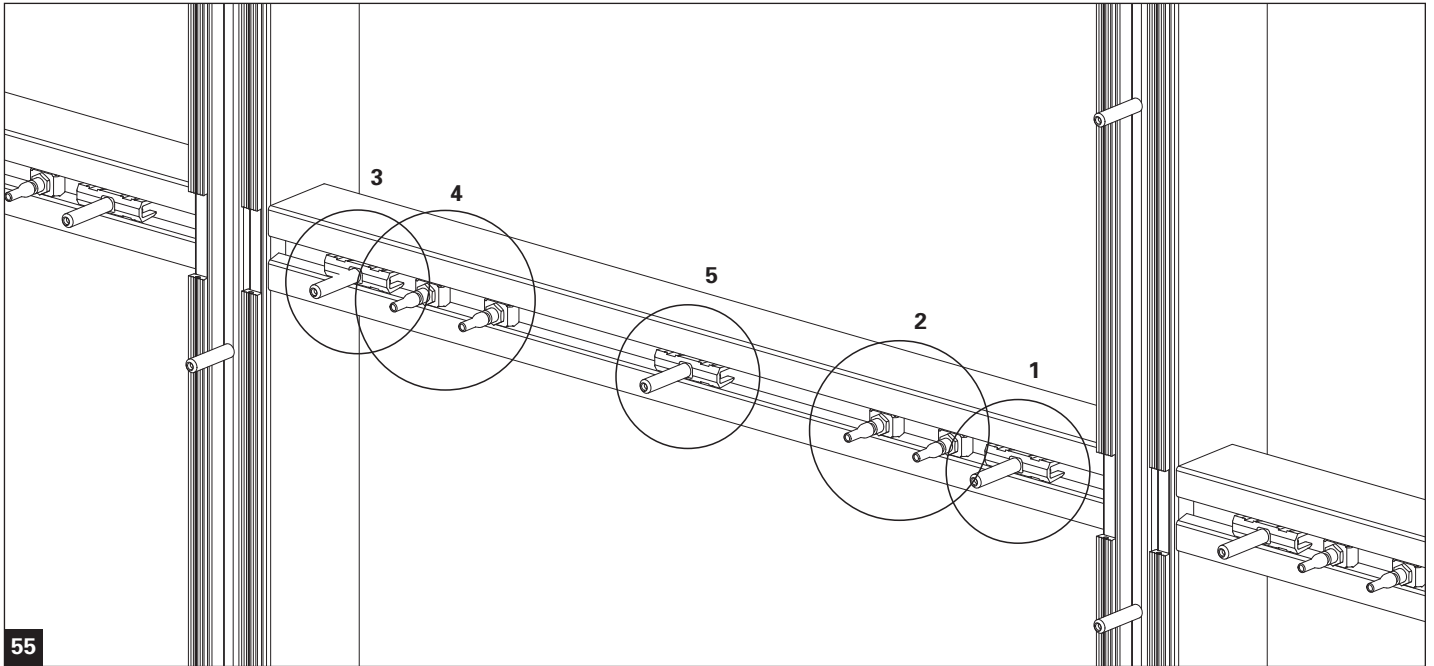



6.1 Montage Innendichtung horizontal  
6.1 Montage joint intérieur horizontal

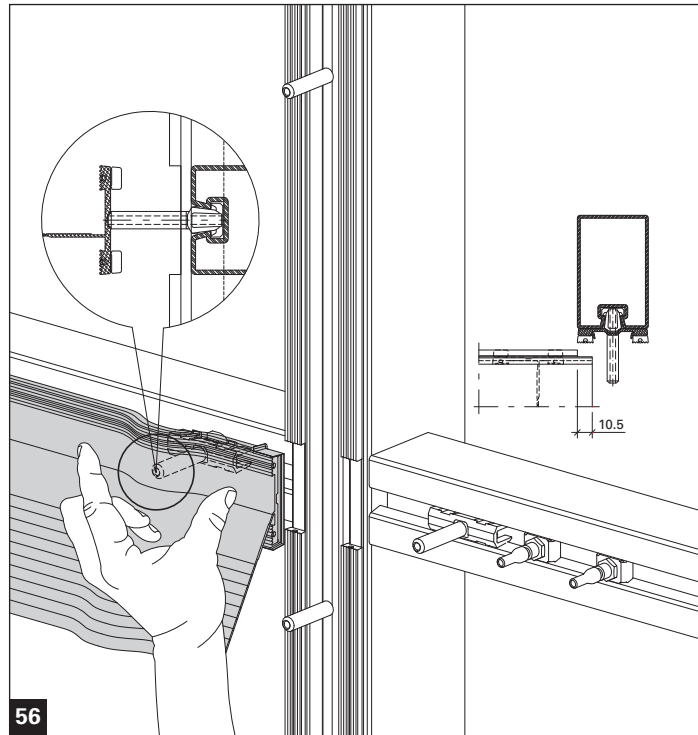

6.1 Assembly horizontal internal gasket  
6.1 Montaggio guarnizione interna orizzontale

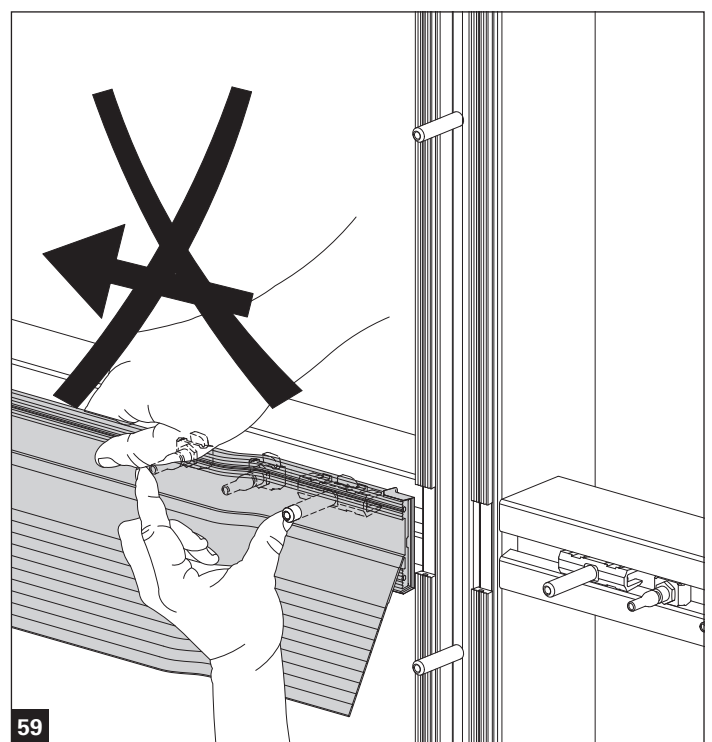
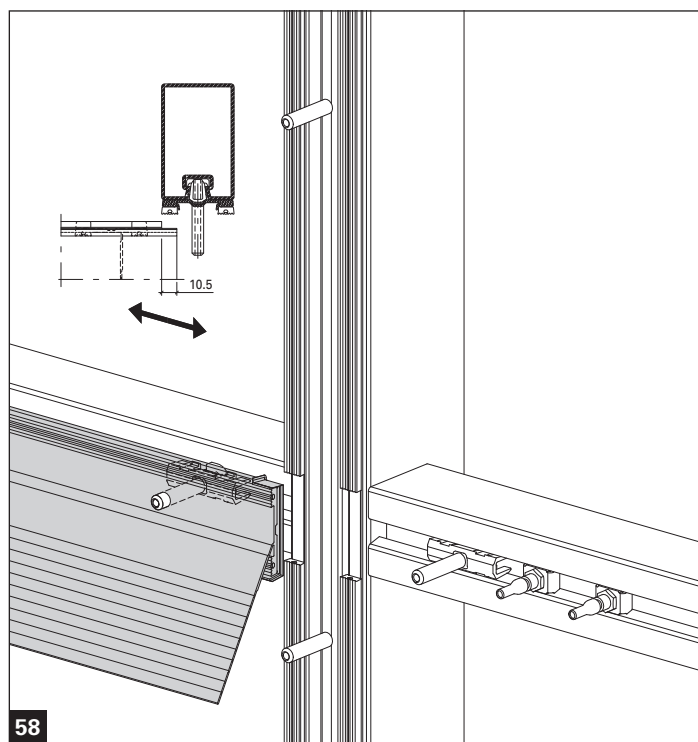
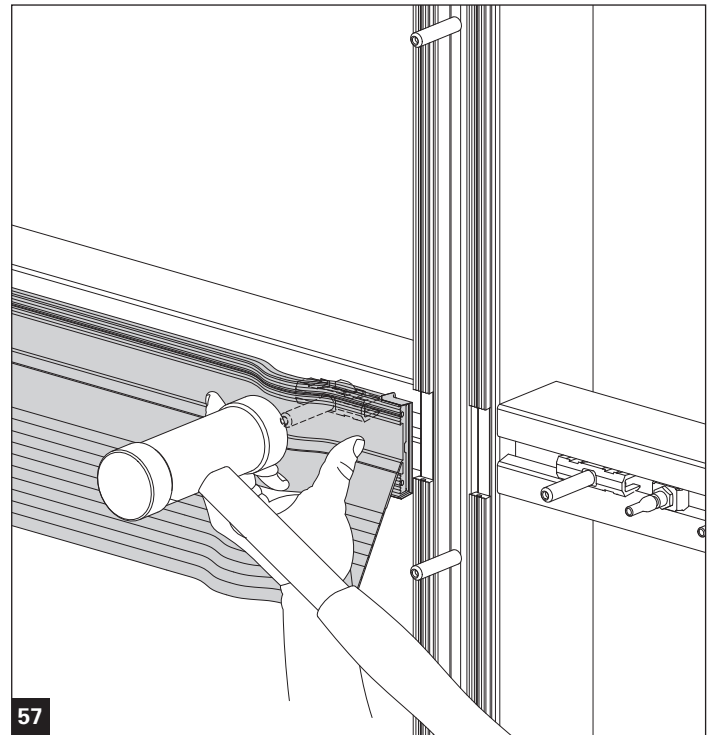

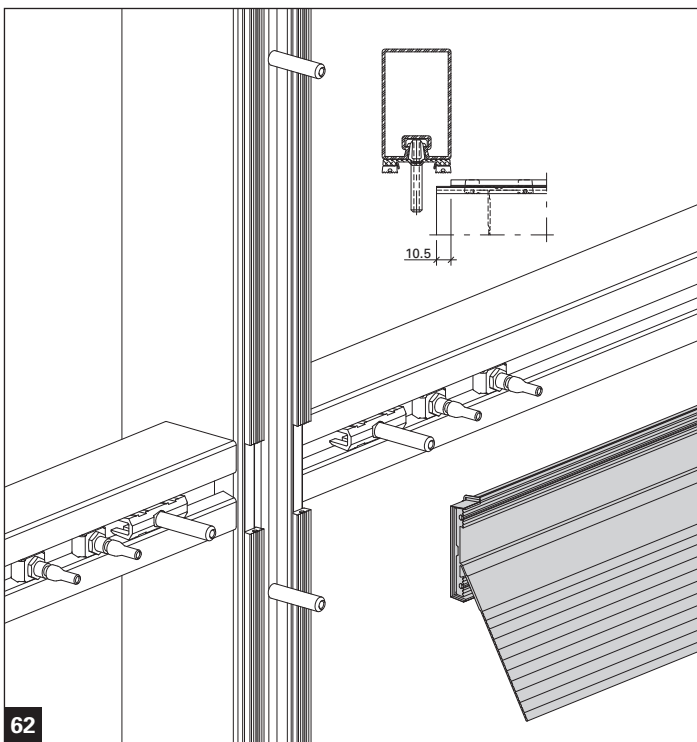
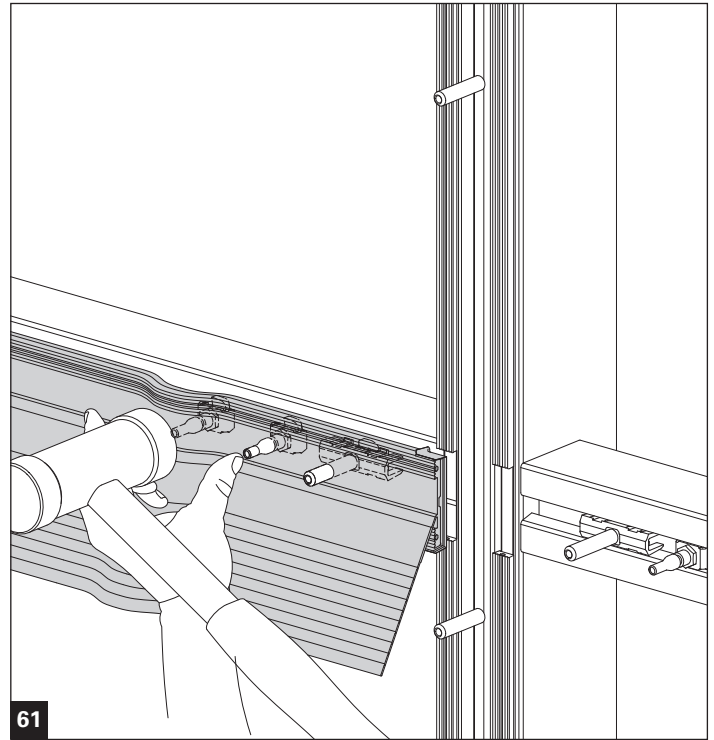
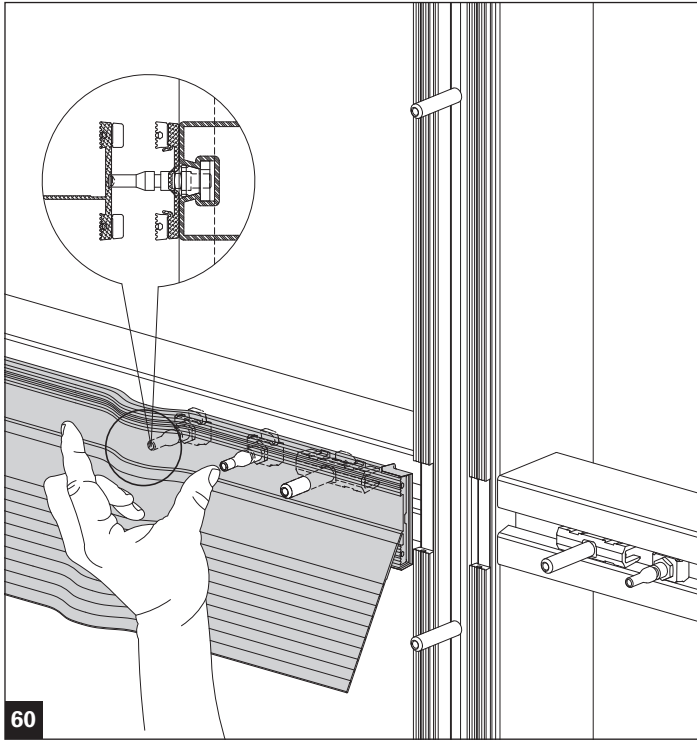

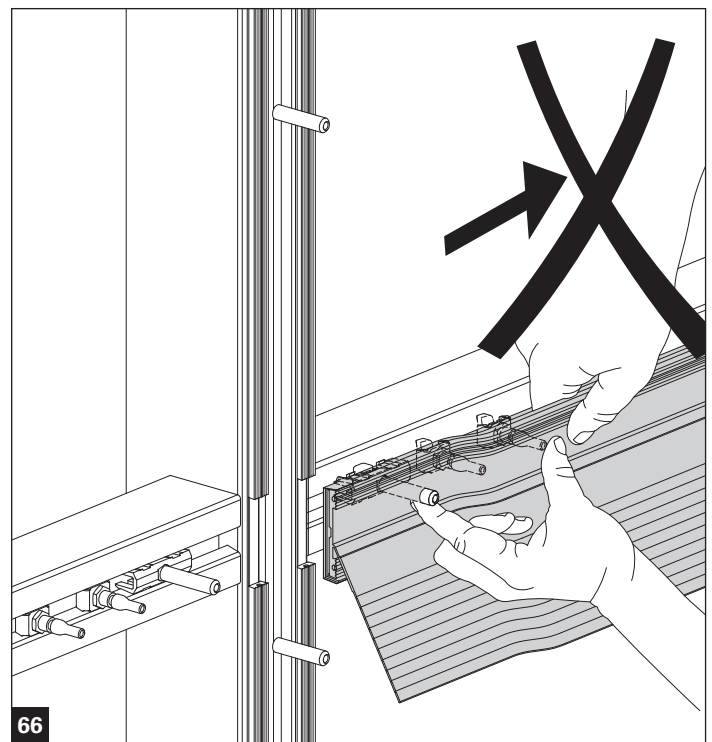
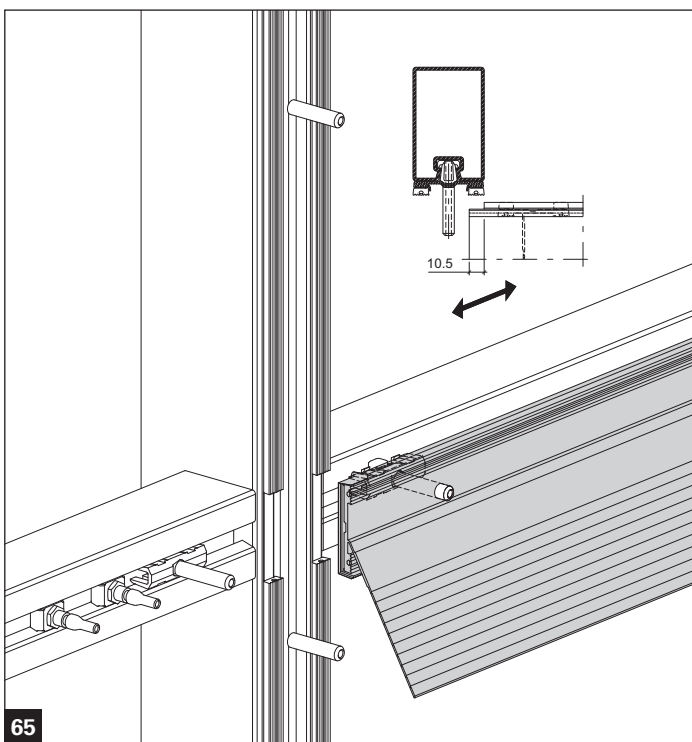
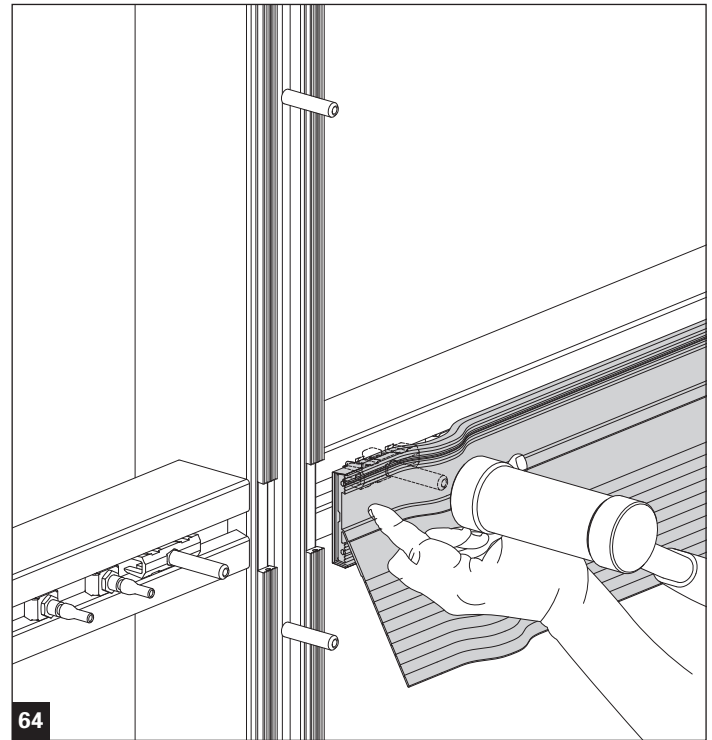
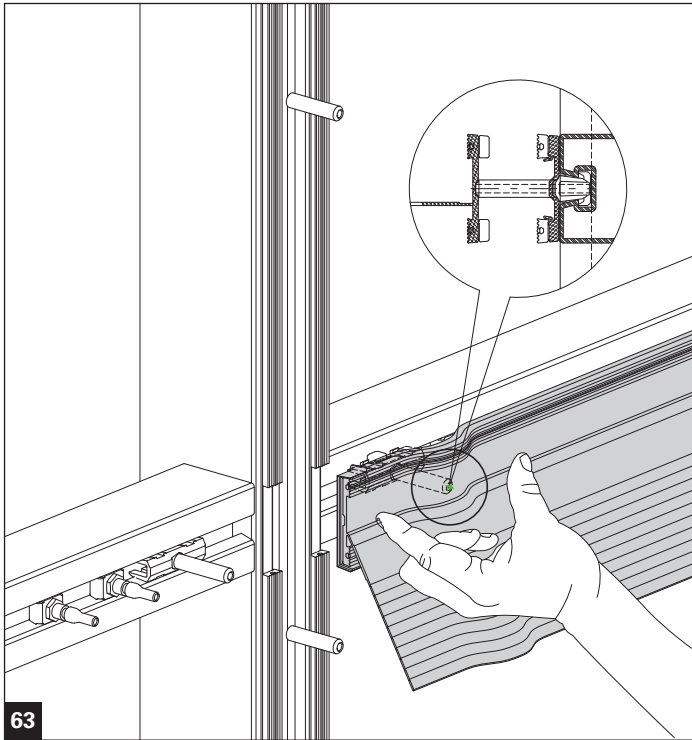

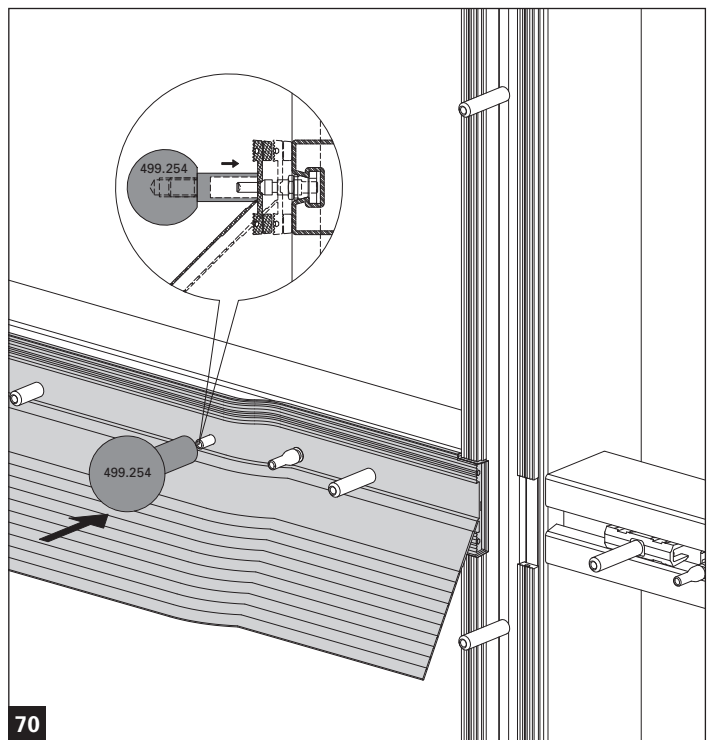
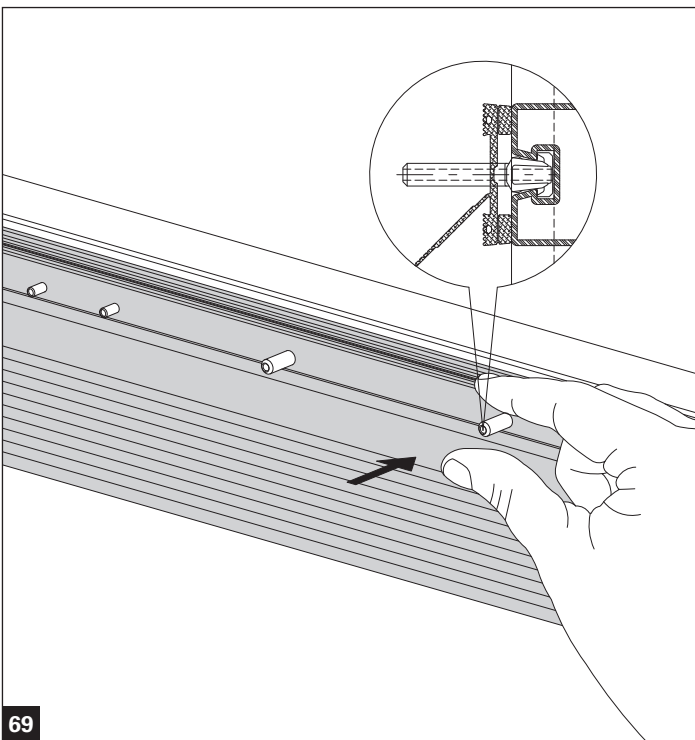
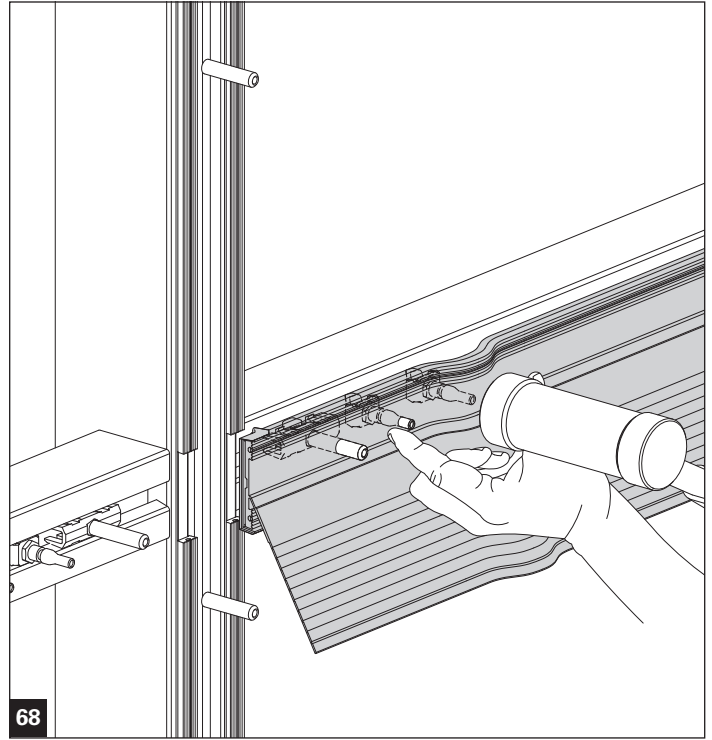
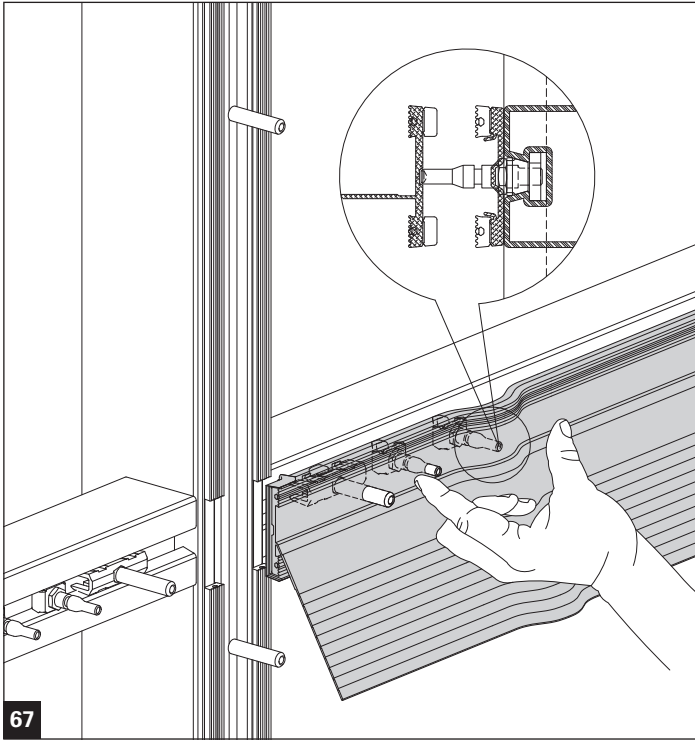

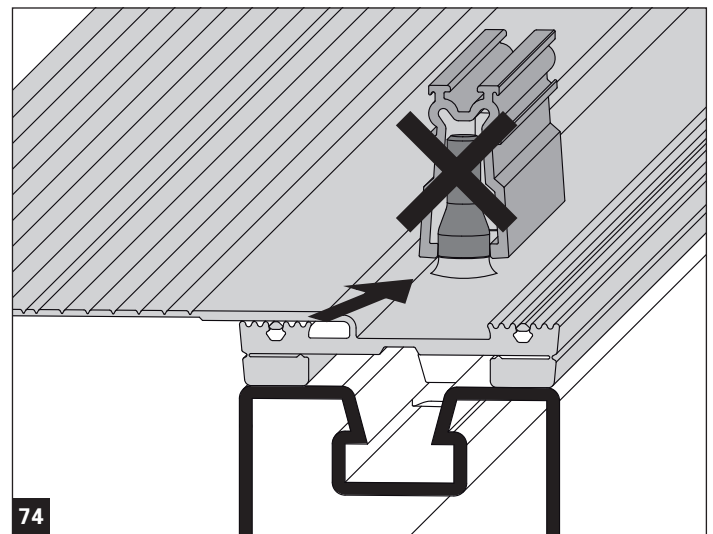
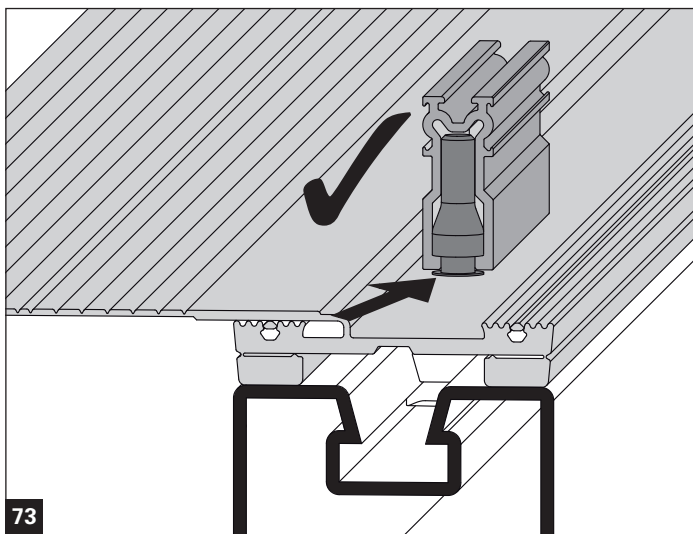
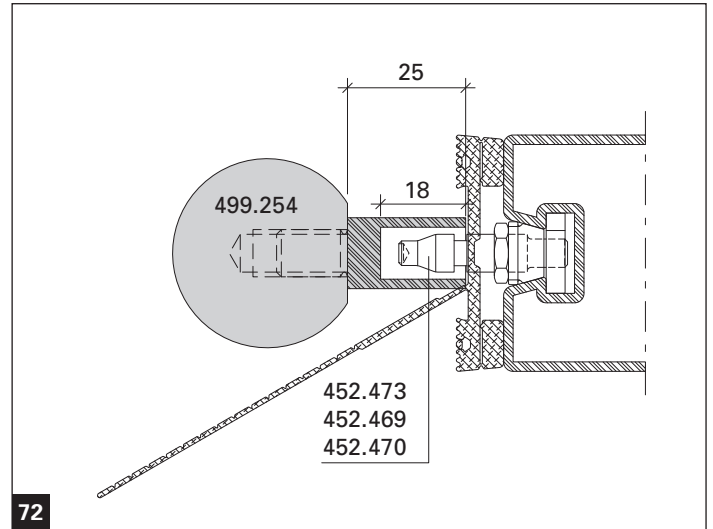
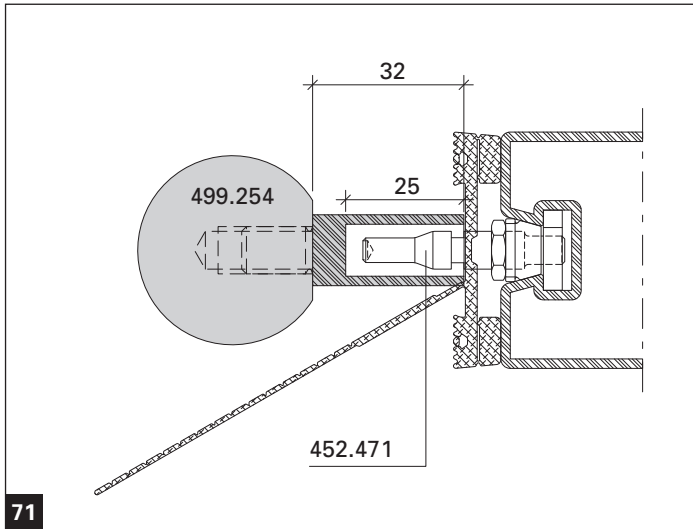

Werkzeug 499.254 ausschliesslich für die  
Glasauflage verwenden (ansonsten Nylonhammer)

N'utiliser l'outil 499.254 que pour le support de  
vitrage (sinon le marteau à tête en nylon)

Only tool 499.254 to be used for the glazing support  
(apart from nylon hammer)

Attrezzo 499.254 solo per l'uso sul supporto vetri  
(altrimenti con martello in nylon)

- 6.2 Verklebung Innendichtung horizontal mit der Innendichtung vertikal  
6.2 Collage joint intérieur horizontal / joint intérieur vertical

- 6.2 Bonding of the horizontal internal weatherstrip to the vertical internal weatherstrip  
6.2 Incollaggio della guarnizione interna orizzontale con quella verticale

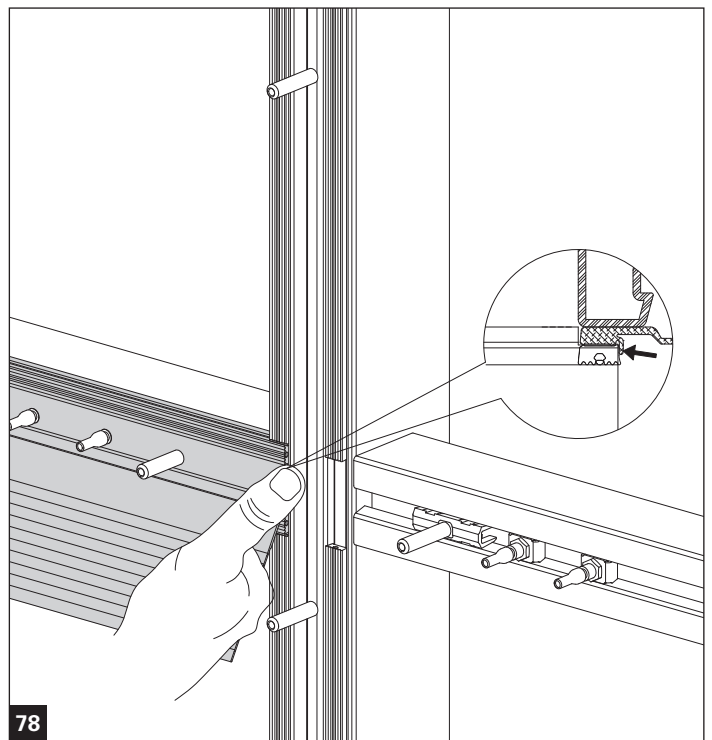
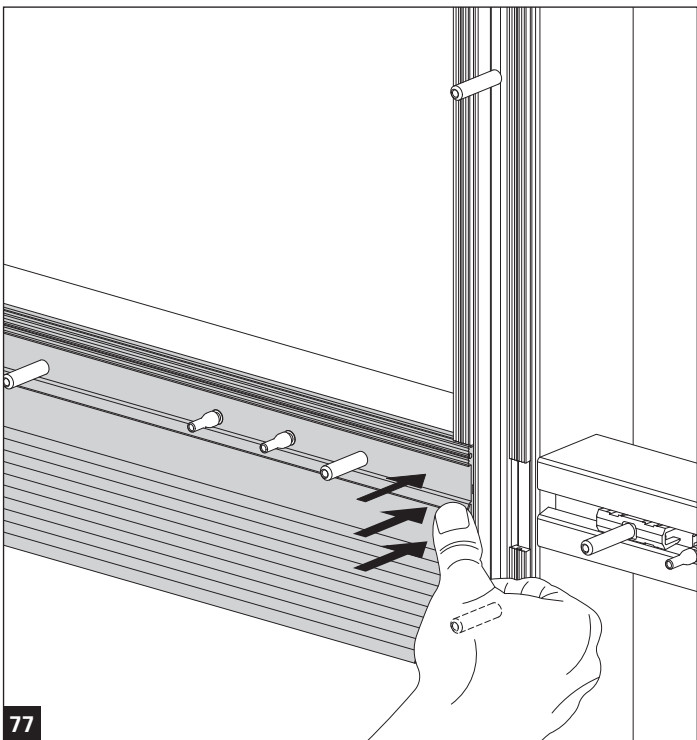
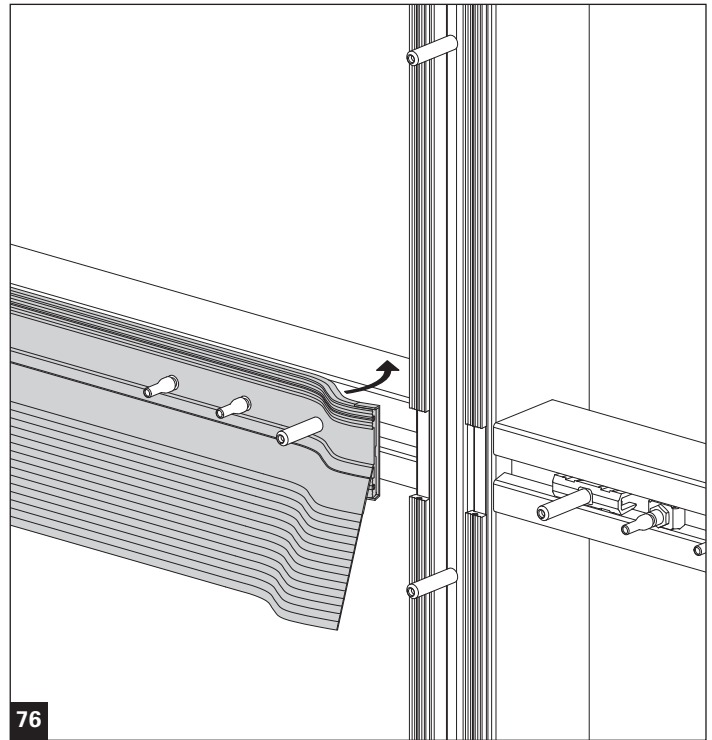
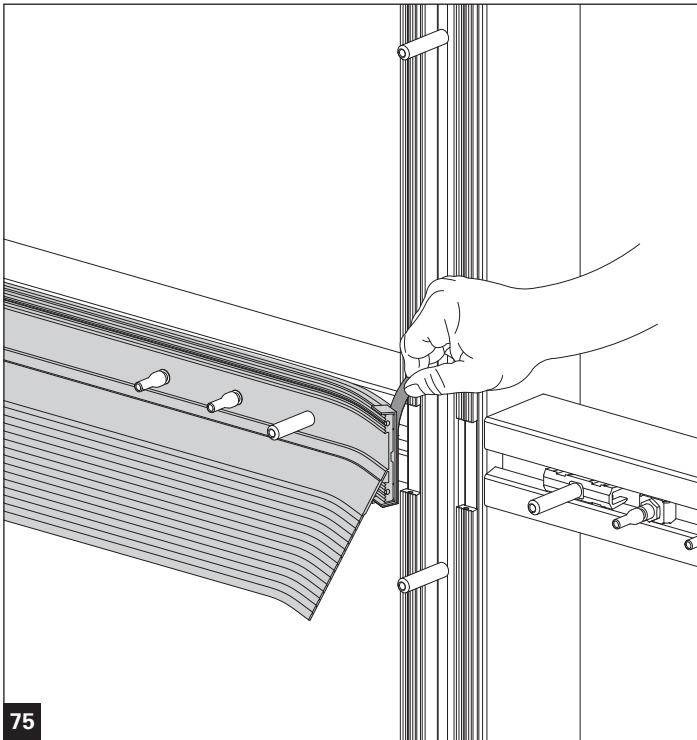

6.3 Ausnehmung Glasaufleger eingeschweisst  
6.3 Évidement soudé dans la zone du support de vitrage

6.3 Recess in area of welded glazing support  
6.3 Asola per il supporto vetro saldato

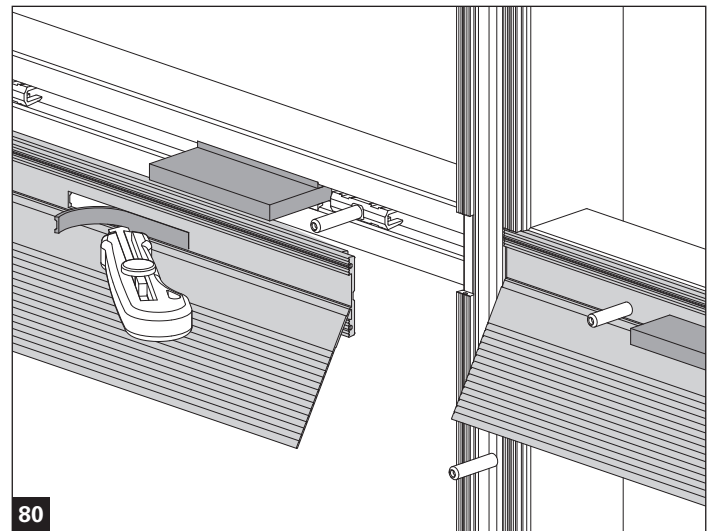
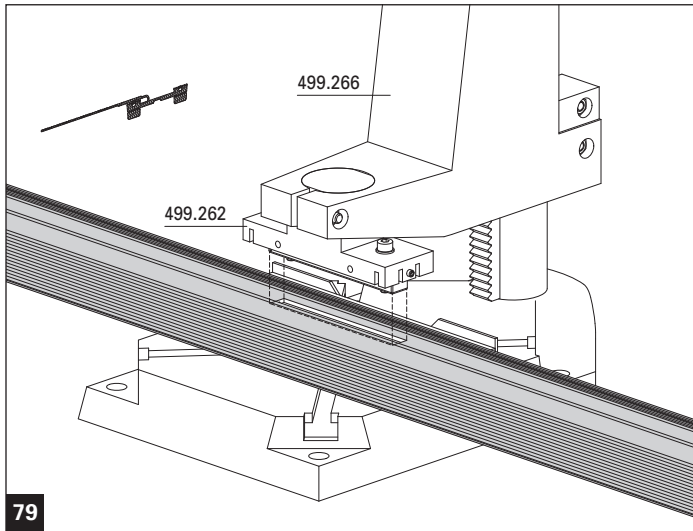

Ausklüpfung mit Dichtungsstanze 499.266 und Stanzwerkzeug 499.262

Entaille avec poinçon à joints 499.266 et outil de poinçonnage 499.262

Notching with gasket punch 499.266 and punching tool 499.262

Intaglio della guarnizione con l'apposita punzonatrice 499.266 e trancia 499.262

Alternative: Ausklüpfung der Dichtung mit Cutter

Alternative: Entaille du joint avec couteau

Alternative: Notching gasket with cutter

In alternativa: Intaglio della guarnizione con un trincetto

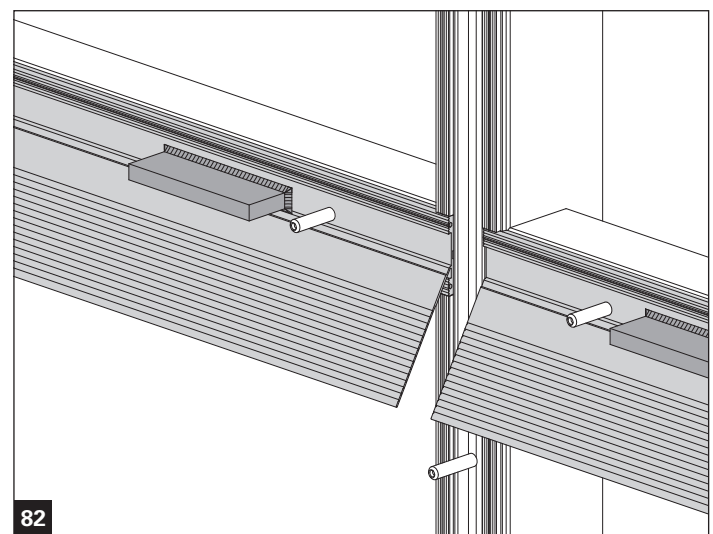
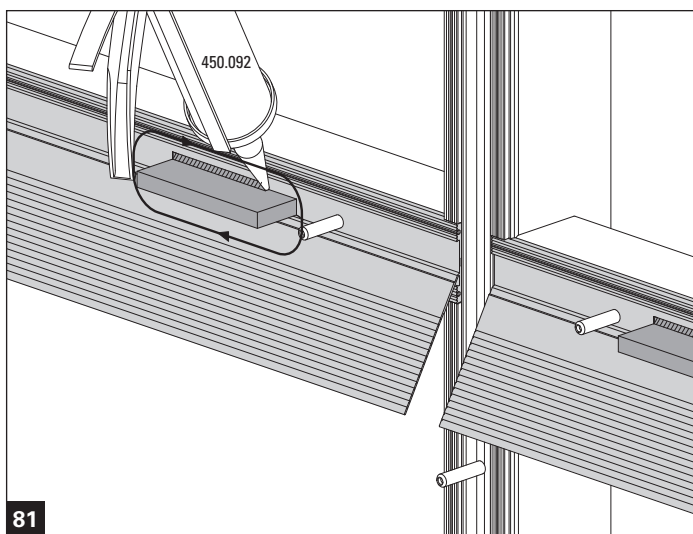

Klebefläche reinigen mit 450.091

Nettoyer la surfaces de collage avec 450.091

Clean adhesive surface with 450.091

Pulire la superficie di incollaggio con 450.091

**7. Montage Glasauflage und Glasklotz**

**7. Montage du support et de la cale de vitrage**

**7. Installation of glass support and glazing block**

**7. Montaggio del supporto vetro e dello spessore vetro**

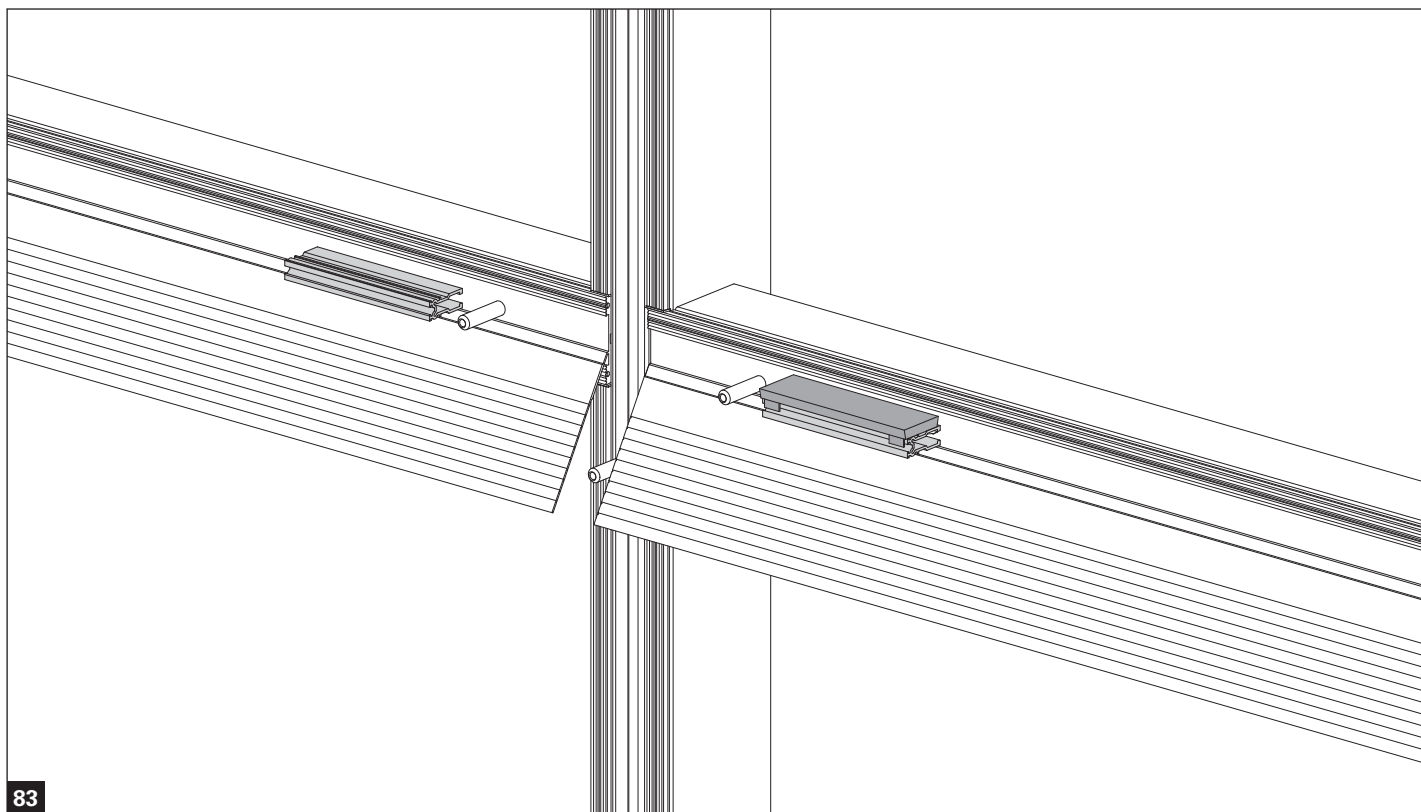

83



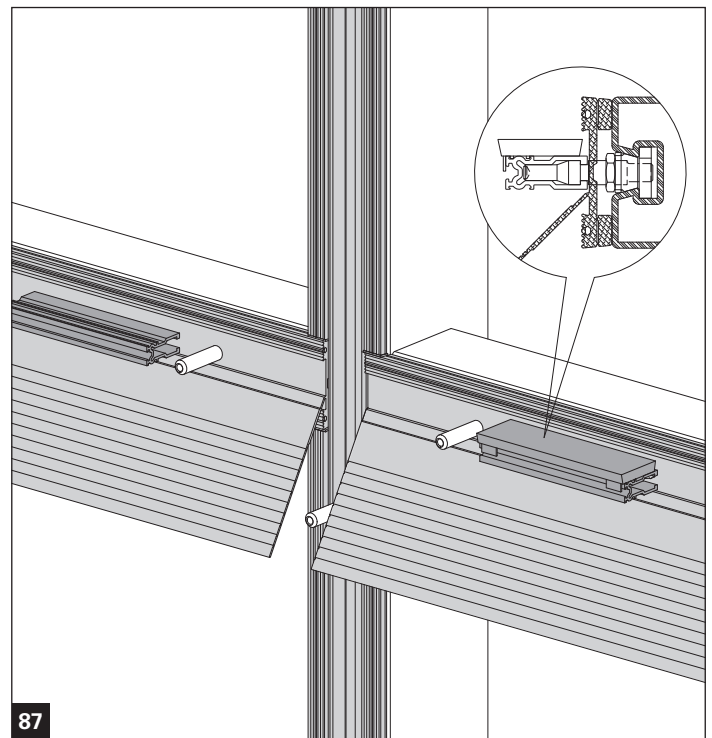
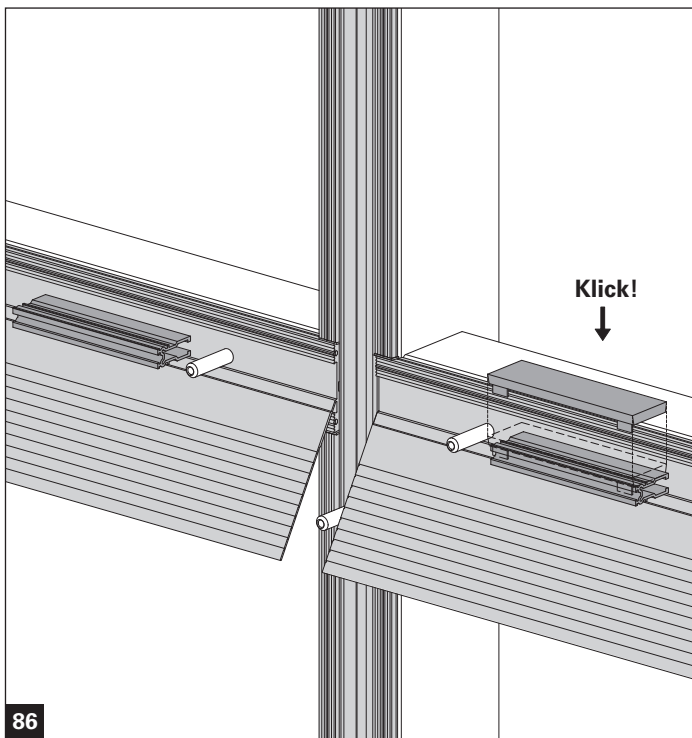
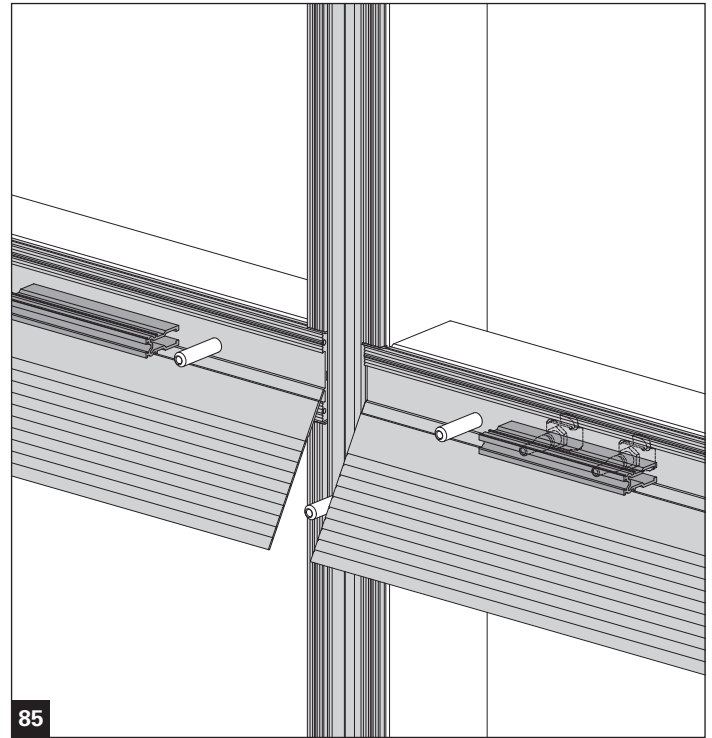
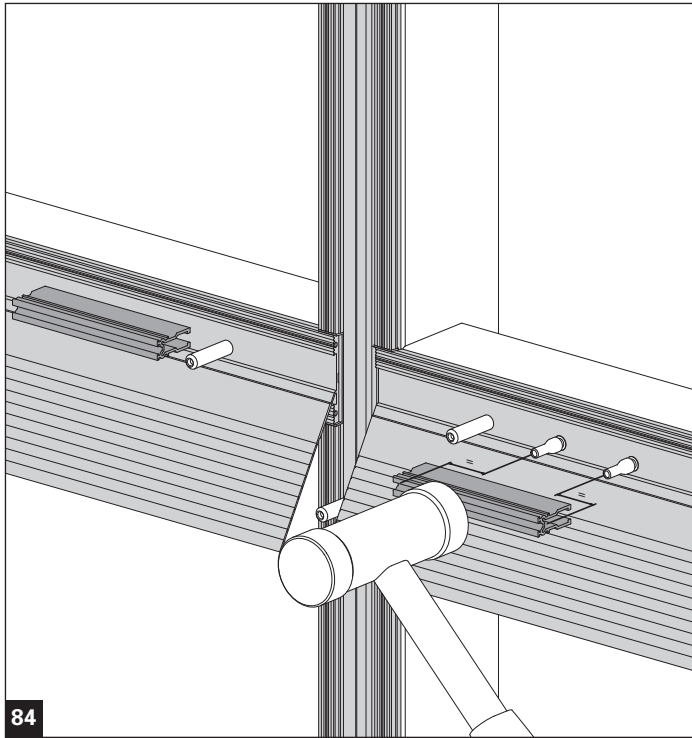

8. Glaseinstand

8. Prise en feuillure

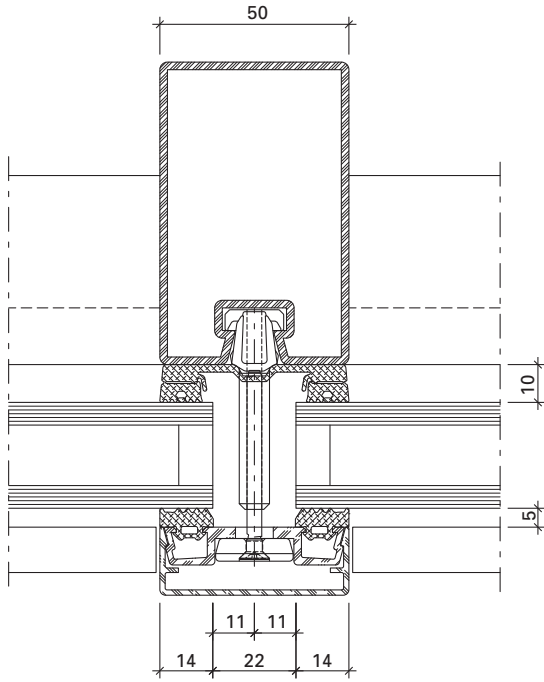

8. Glass edge cover

8. Posizionamento del vetro

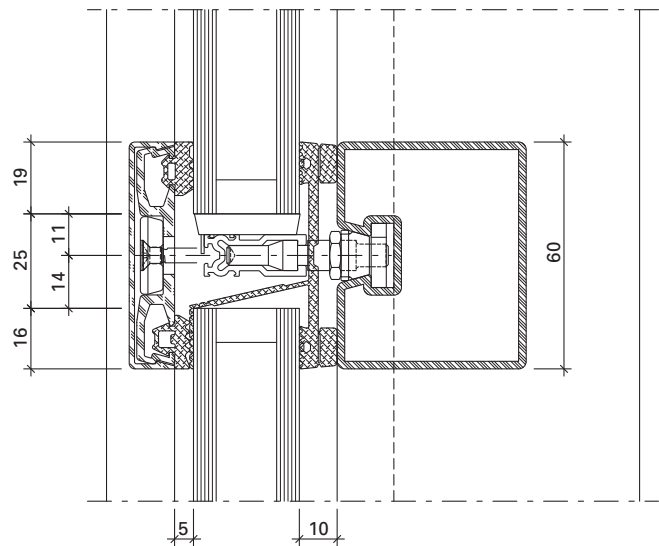
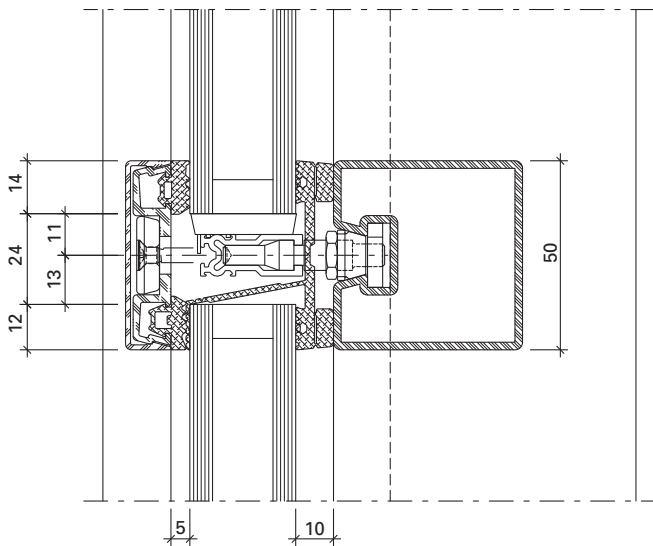
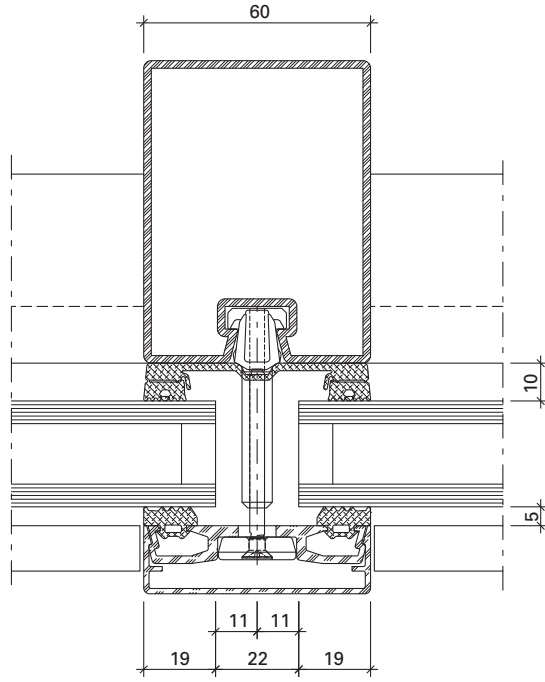

9 Einbau Füllelemente

9. Montage des éléments de remplissage

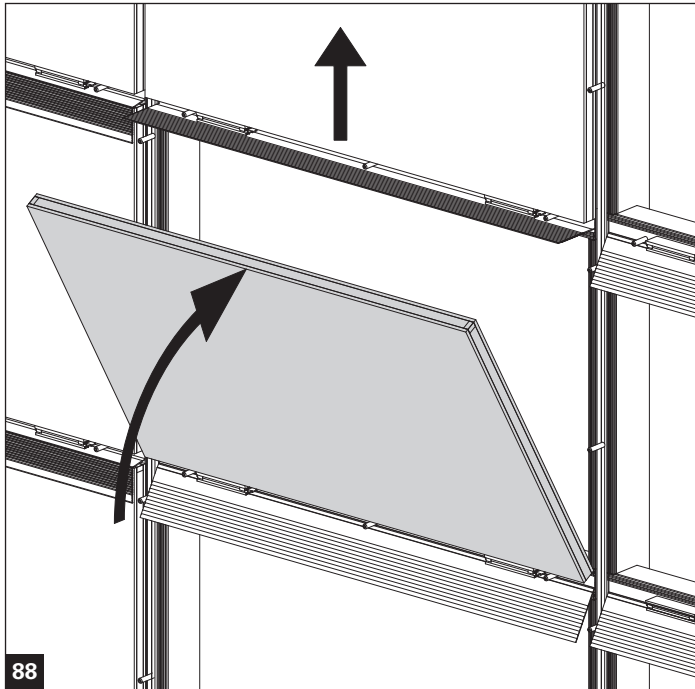

9. Inserting infill units

9. Montaggio degli elementi di riempimento

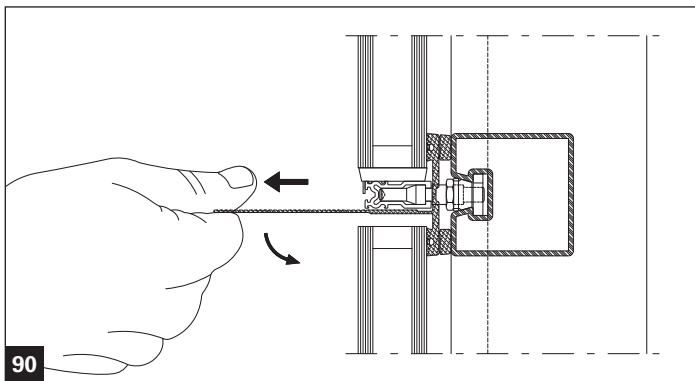
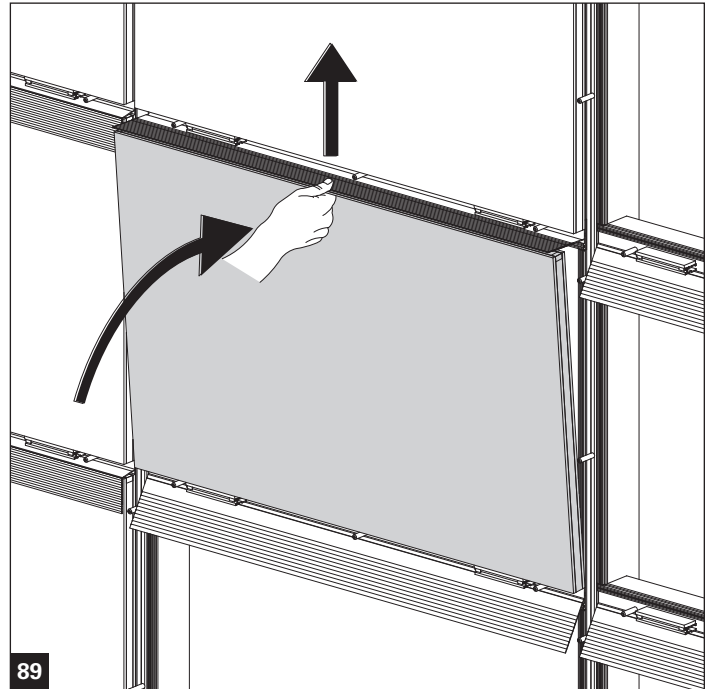

Füllelement vorsichtig auf Glasklotz abstellen, Dichtungslappen anheben und anschliessend sorgfältig anlegen.

Poser avec précaution l'élément de remplissage sur la cale de vitrage, soulever les lèvres d'étanchéité et les reposer ensuite avec précaution.

Carefully place infill unit on glazing block, lift gasket lips and then carefully position.

Appoggiare con cautela l'elemento di riempimento sullo spessore, sollevare i labbri della guarnizione, quindi riposizionarli con cura a contatto con l'elemento.

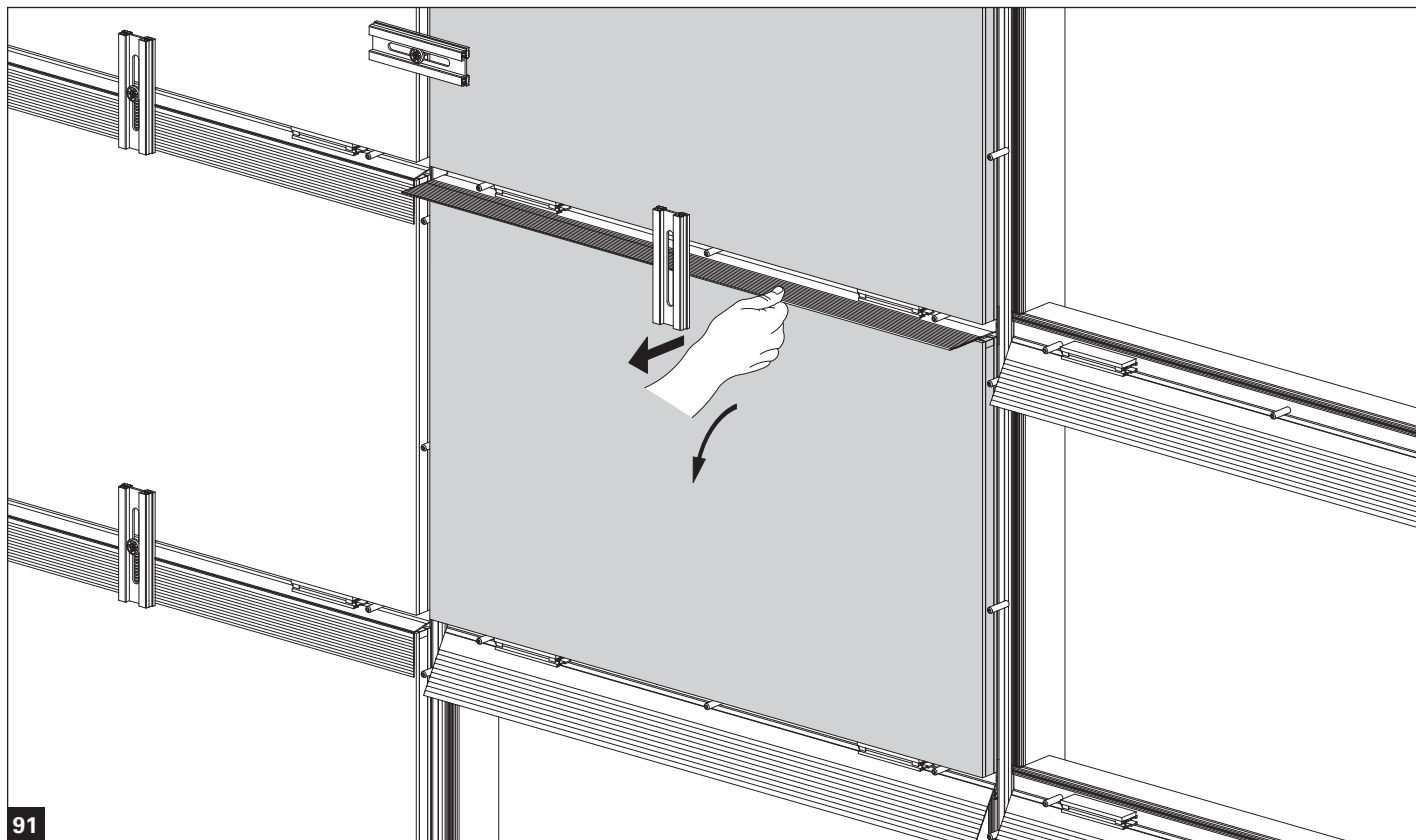

Dichtungslappen leicht anspannen und gleichmässig an Glasscheibe andrücken

Tendre légèrement les lèvres d'étanchéité et les presser homogènement sur la vitre

Apply slight pressure on the gasket lips and press onto glass pane evenly

Sottoporre a leggera pressione i labbri della guarnizione, poi premerli uniformemente sulla lastra di vetro

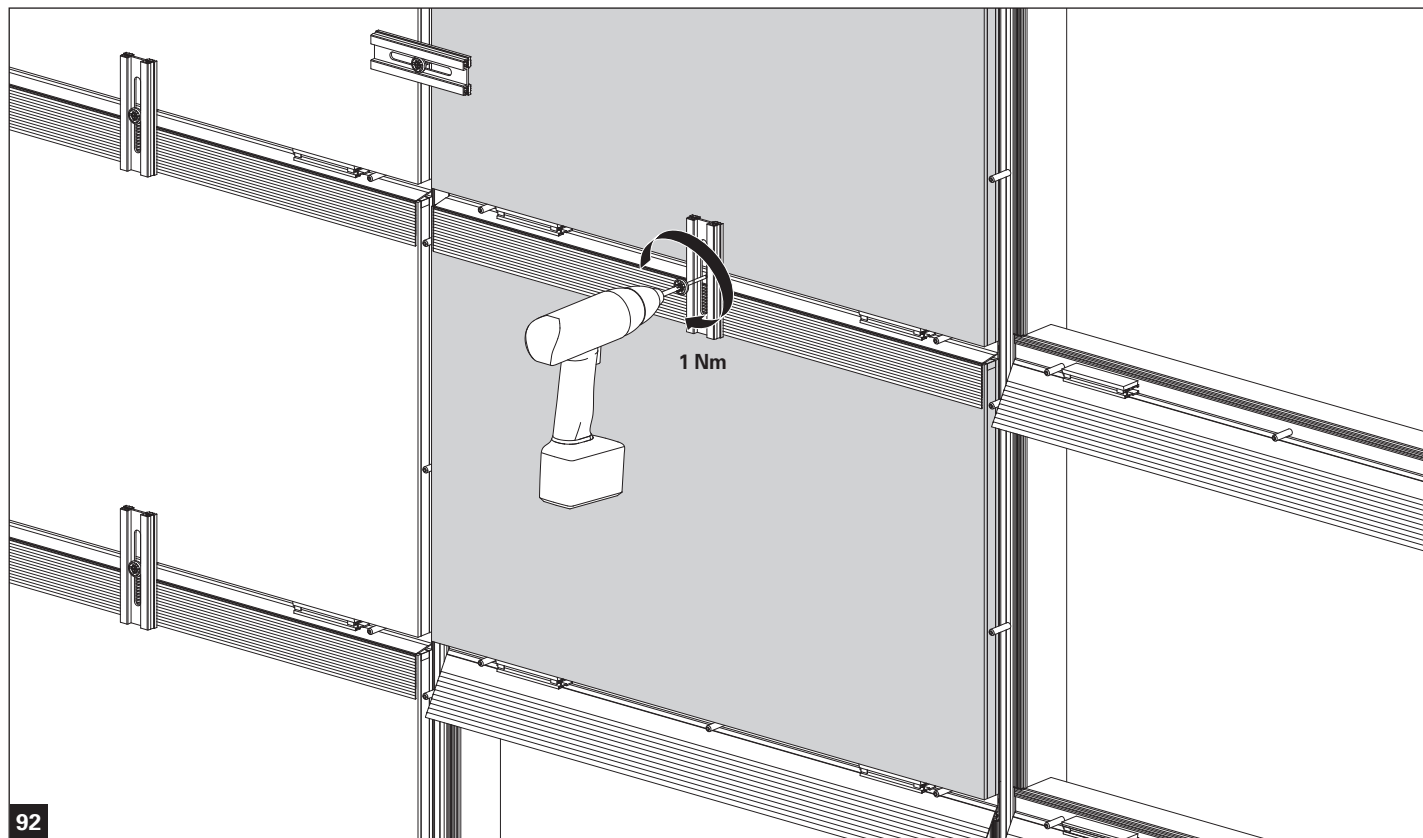

Füllelement mit Profilstück sichern

Bloquer l'élément de remplissage avec une pièce profilée

Secure infill unit with section of profile

Bloccare l'elemento di riempimento con un pezzo di profilo



Die Anzahl der Sicherungen ist den Gegebenheiten (Glasgröße, Windlast, etc.) anzupassen.

Le nombre de sécurités doit être adapté aux conditions (taille de la vitre, charge de vent, etc.).

The quantity of securing devices must be adapted to suit conditions (glass size, wind load etc.).

Il numero delle protezioni va adeguato alle condizioni specifiche (spessore del vetro, spinta del vento, ecc.).

**10. Zuschnitt und Montage der Anpressprofile**

**10. Découpe et montage des profilés de fixation**

10.1 Zuschnitt vertikale Anpressprofile  
 10.1 Coupe des profilés de fixation vertical

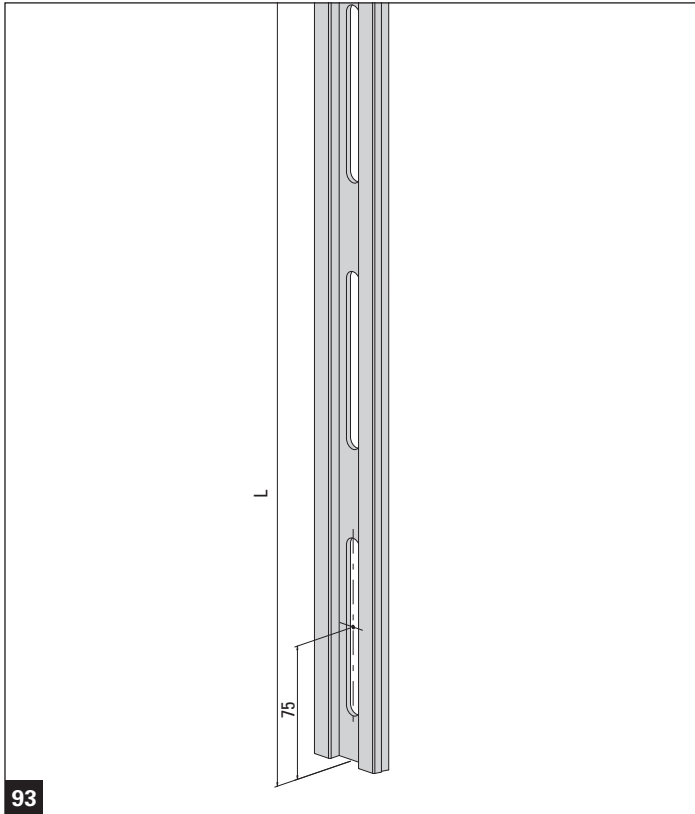

93

Berechnung Länge Anpressprofil  
 Calcul de la longueur du profilé de fixation  
 Calculation of length of clamping profile  
 Calcolo della lunghezza del pressore

a = Achsmass  
 b = Ansichtsbreite  
 Zu = Zuschlag unten  
 Zo = Zuschlag oben

a = Entraxe  
 b = Largeur de face  
 Zu = Supplément en bas  
 Zo = Supplément en haut

a = Axis dimension  
 b = Face width  
 Zu = Supplement, bottom  
 Zo = Supplement, top

a = Interasse  
 b = Larghezza in vista  
 Zu = Maggiorazione in basso  
 Zo = Maggiorazione in alto

**10. Cutting and installation of clamping sections**

**10. Taglio e montaggio dei profili di fissaggio**

10.1 Cutting of vertical clamping sections  
 10.1 Taglio dei profili di fissaggio verticale

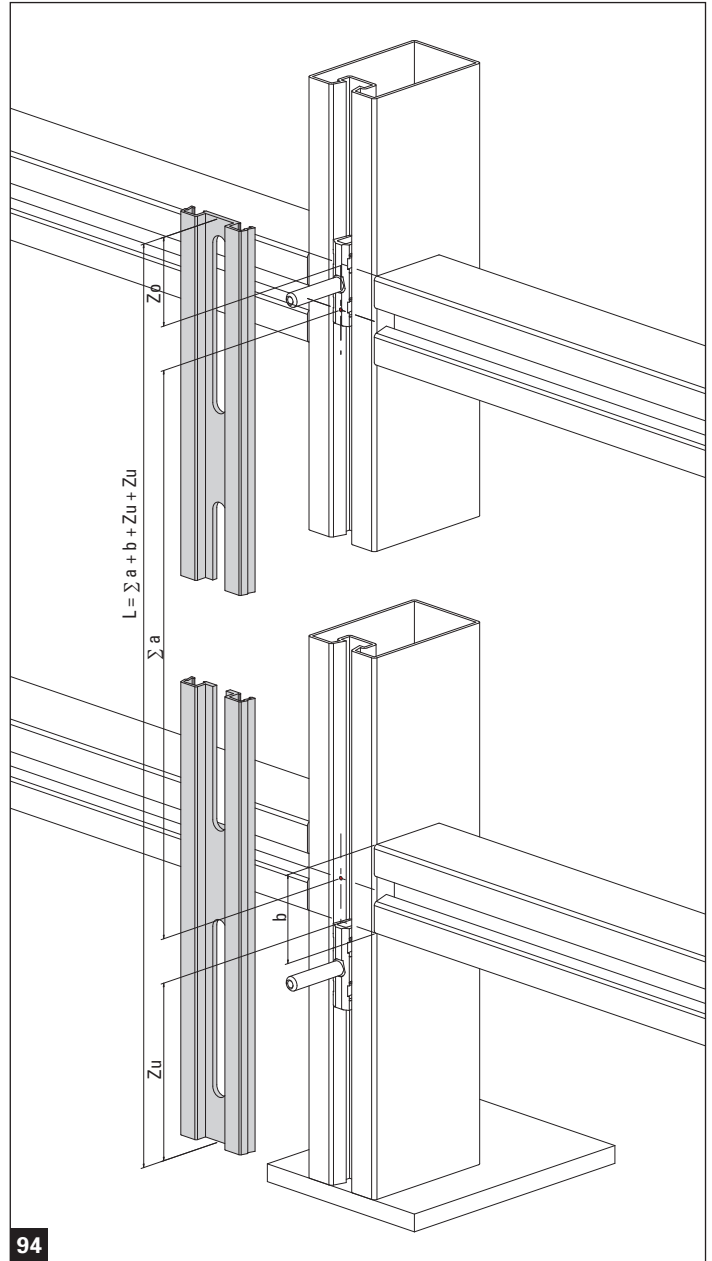

94



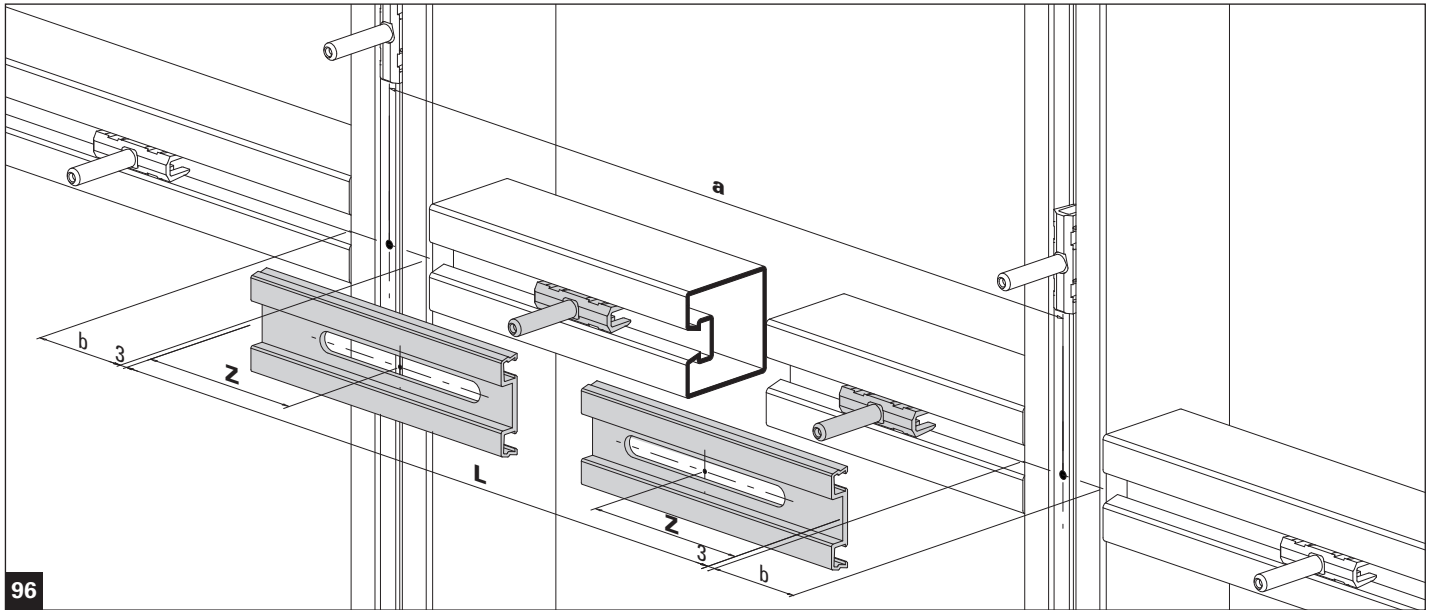

96

**Berechnung L und Z**

$$L = a - b - 6$$

$$Z = (a - 200) / 150 = \text{Ergebnis}$$

Kommastelle von Ergebnis  $\times 75 + 96 - b/2 = \text{Randabstand } Z$

**Calcul L et Z**

$$L = a - b - 6$$

$$Z = (a - 200) / 150 = \text{Résultat}$$

1<sup>er</sup> virgule décimale du résultat  $\times 75 + 96 - b/2 = \text{Distance périmétrique } Z$

**Calculating L and Z**

$$L = a - b - 6$$

$$Z = (a - 200) / 150 = \text{result}$$

1. Decimal place of result  $\times 75 + 96 - b/2 = \text{Edge distance } Z$

**Calcolo L e Z**

$$L = a - b - 6$$

$$Z = (a - 200) / 150 = \text{Risultato}$$

1. Decimale del risultato  $\times 75 + 96 - b/2 = \text{Distanza dal bordo } Z$

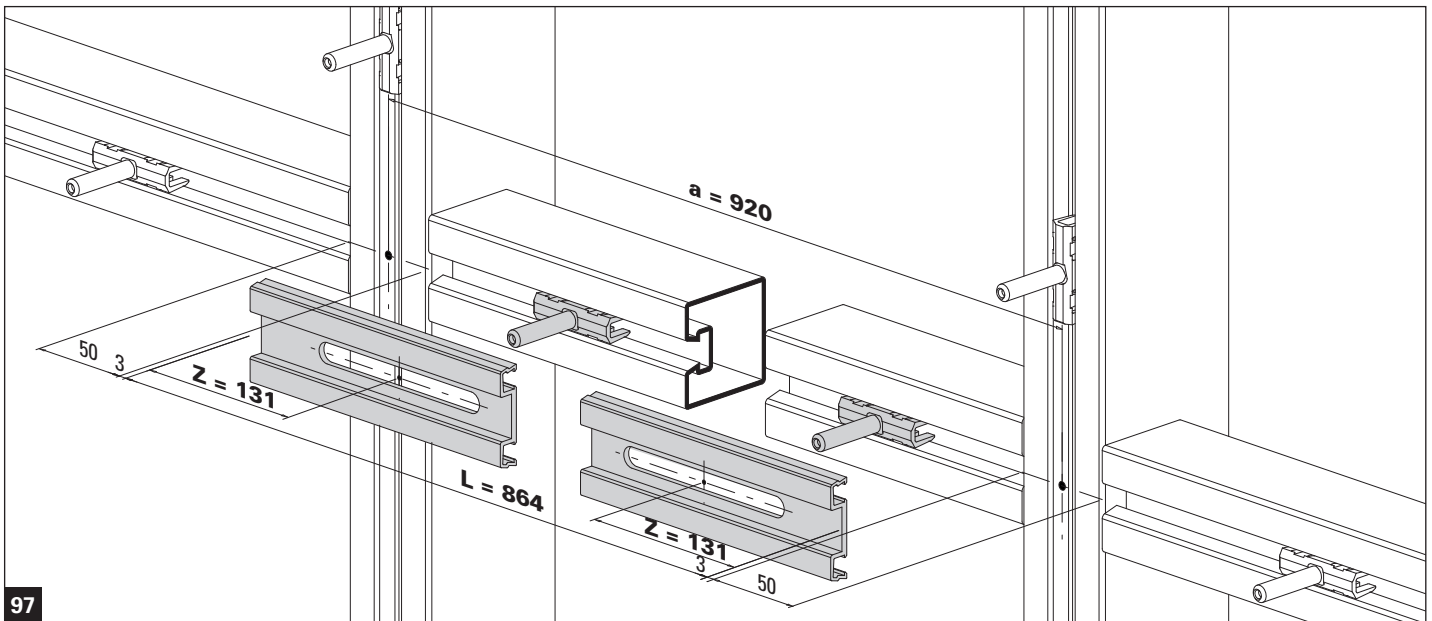

97

**Beispiel / Exemple / Example / Esempio:**

$$L = 920 - 50 - 6 = 862$$

$$Z = (920 - 200) / 150 = 4,8$$

$$0,8 \times 75 + 96 - 25 = 131$$



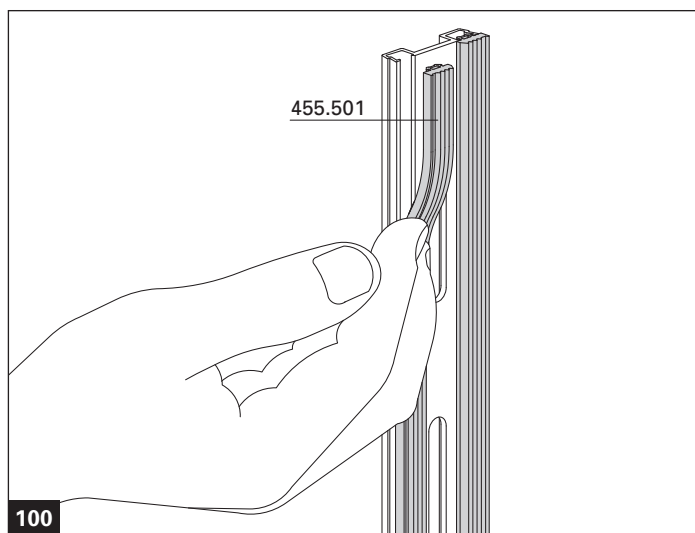
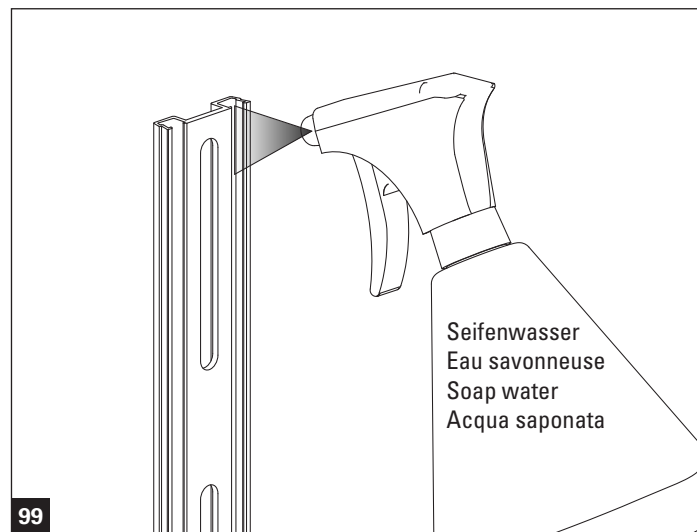
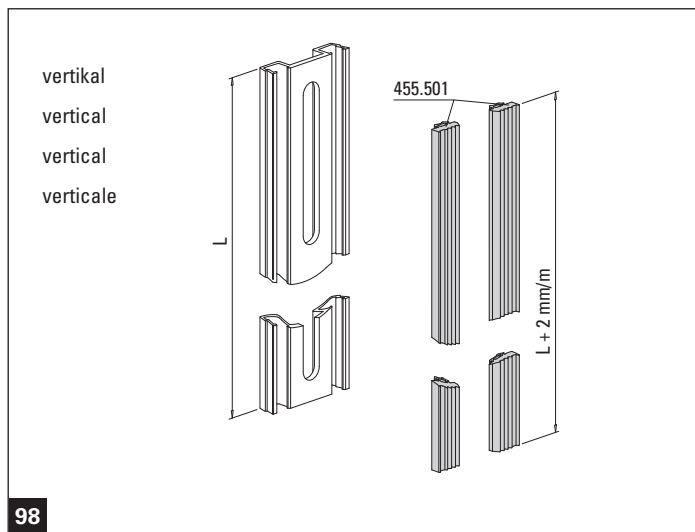

Dichtung darf beim Einbau nicht gestreckt werden.

Le joint ne doit pas être étiré lors de son montage.

The gasket must not be stretched during insertion.

Durante il montaggio la guarnizione non deve essere stirata.

10.3 Zuschnitt und Montage Aussendichtung in Anpressprofil  
 10.3 Découpe et montage du joint extérieur dans le profilé de fixation

10.3 Cutting and installation of external gasket in clamping sections  
 10.3 Taglio e montaggio della guarnizione esterna nel profilo di fissaggio

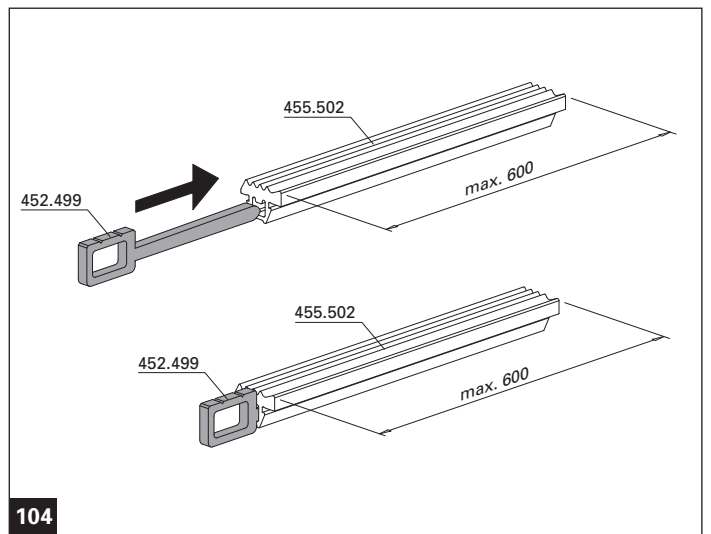
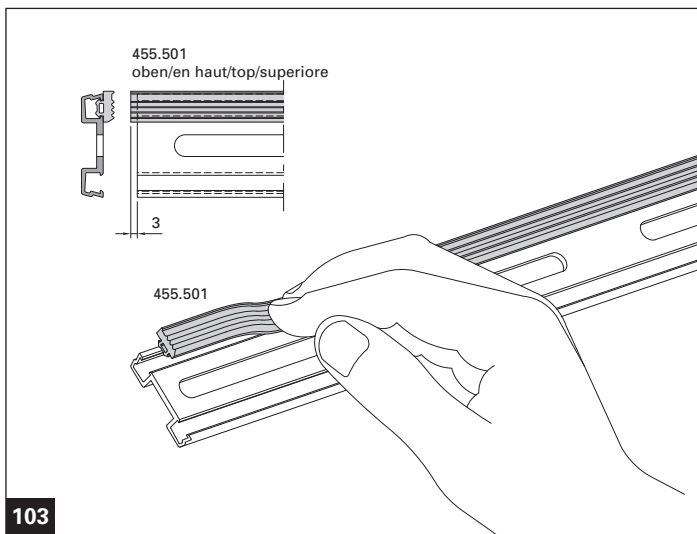
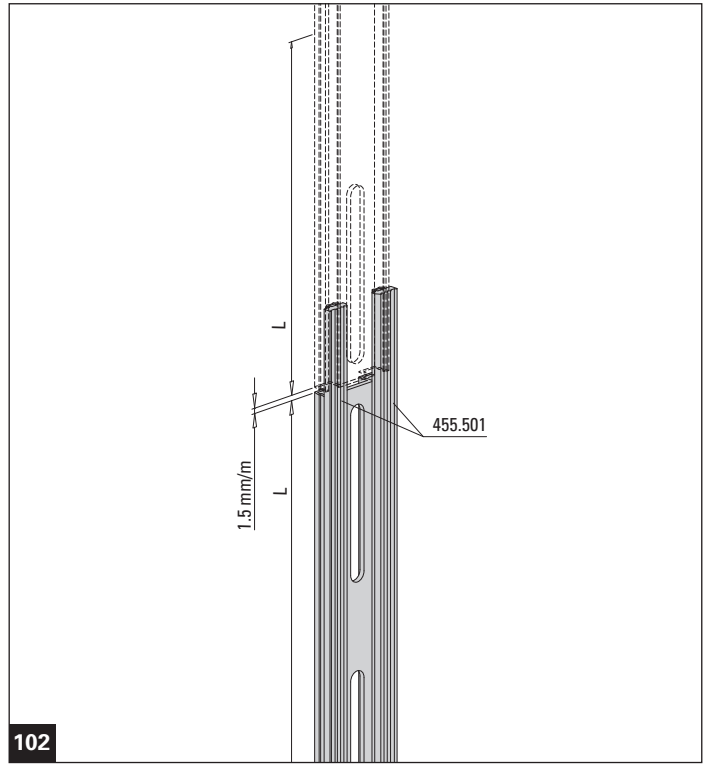
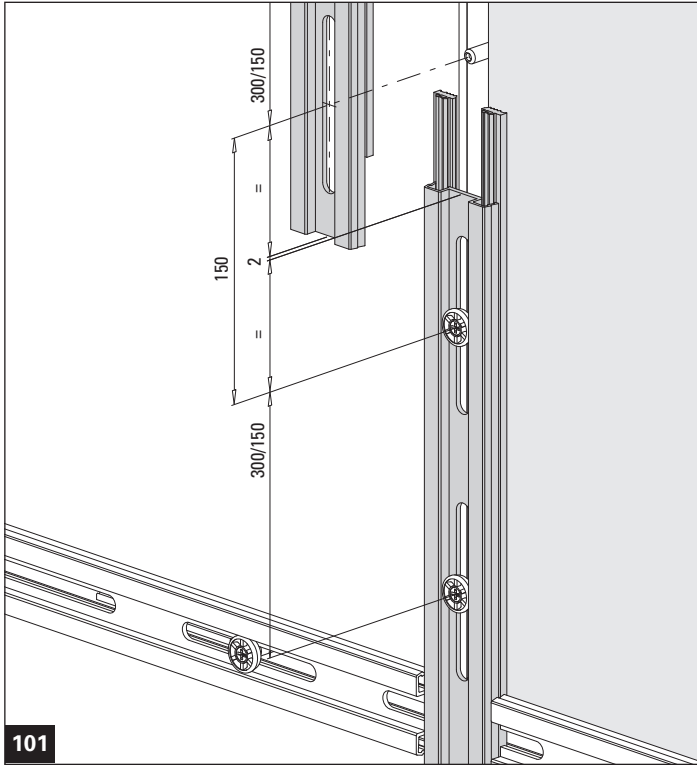

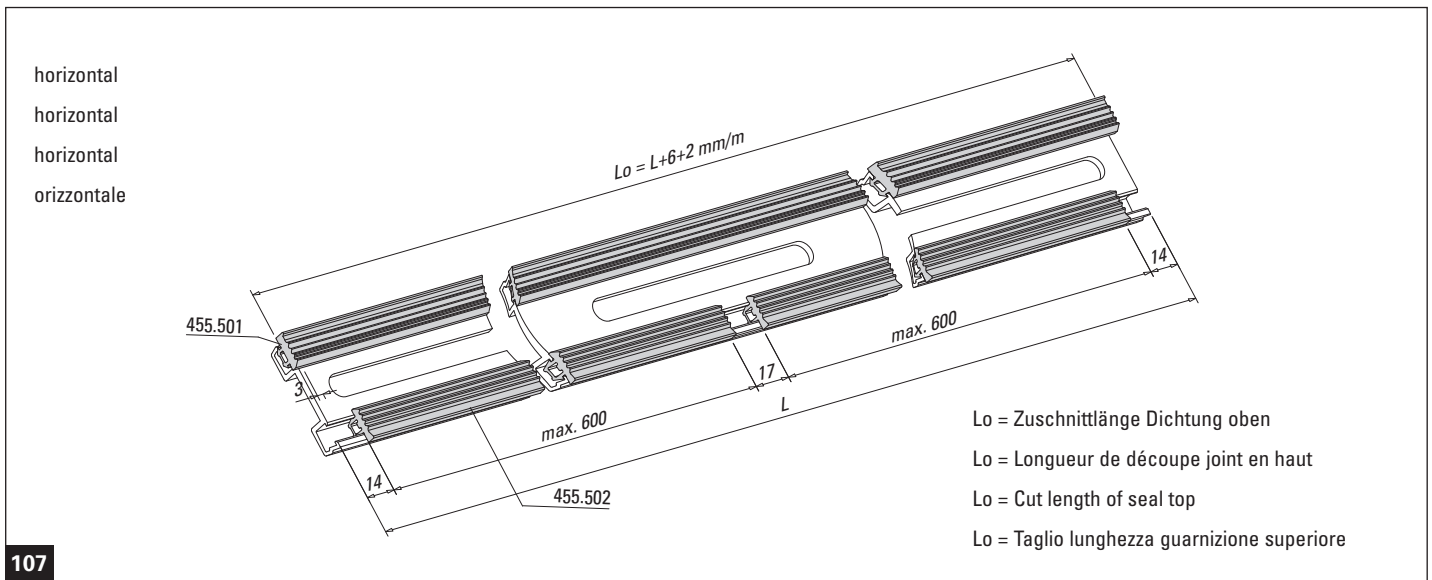
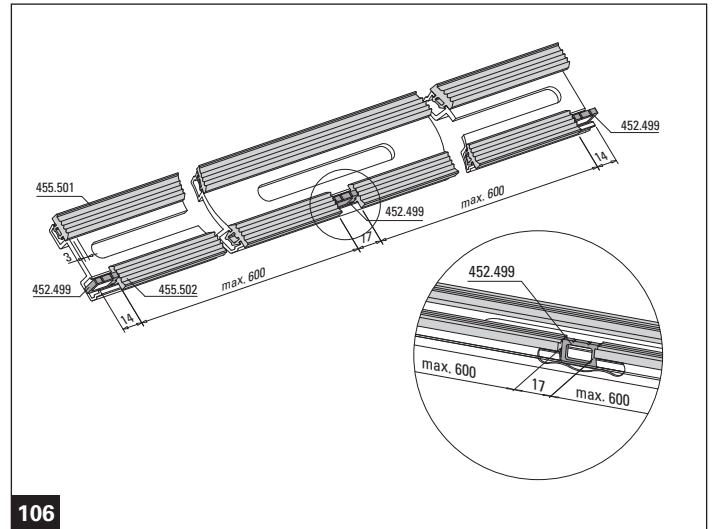
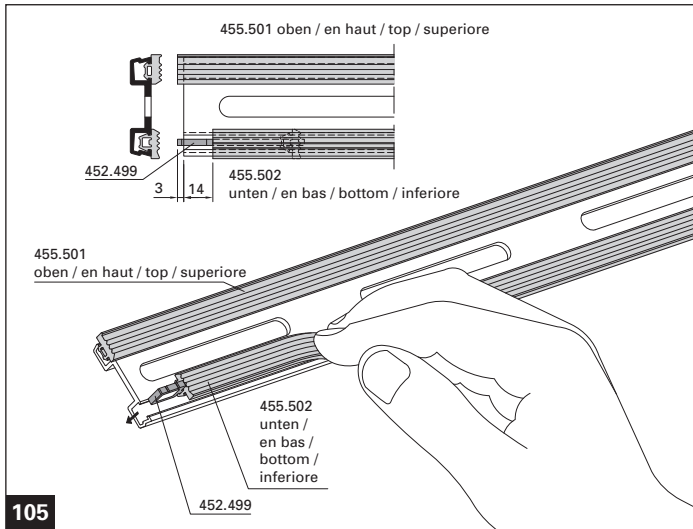

10.4 Montage Anpressprofil vertikal  
10.4 Montage profilés de fixation vertical

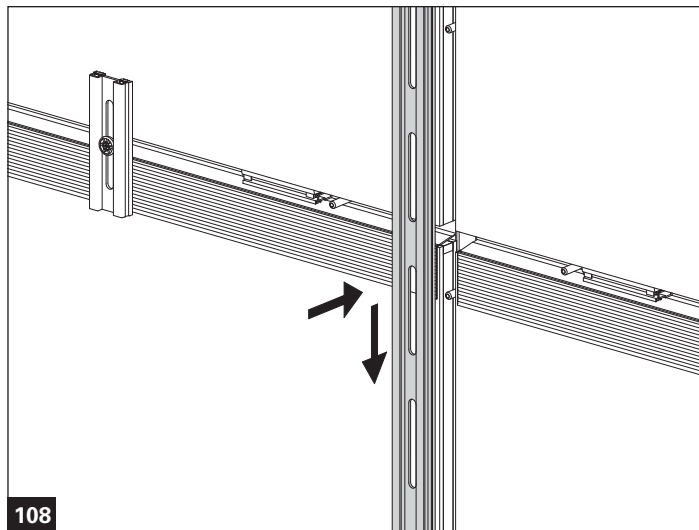

10.4 Assembly vertical clamping sections  
10.4 Montaggio profili di fissaggio verticale

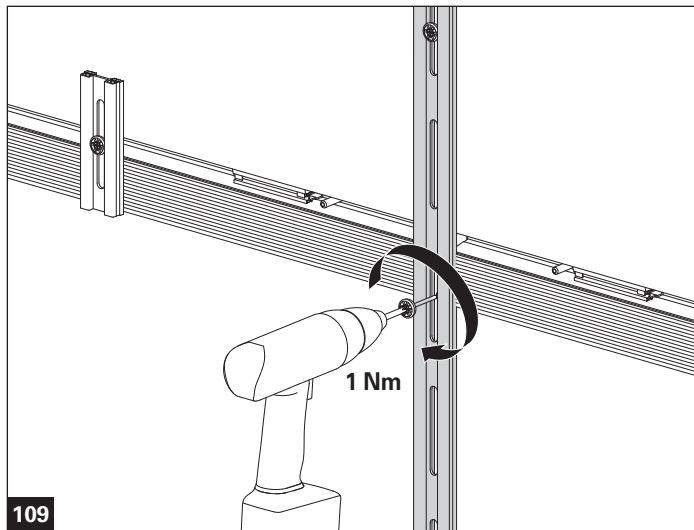

10.5 Montage Anpressprofil horizontal  
10.5 Montage profilés de fixation horizontal

10.5 Assembly horizontal clamping sections  
10.5 Montaggio profili di fissaggio orizzontale

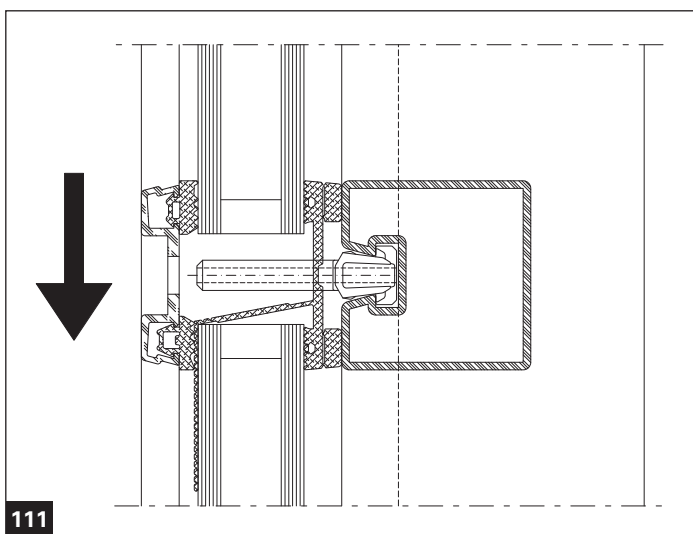
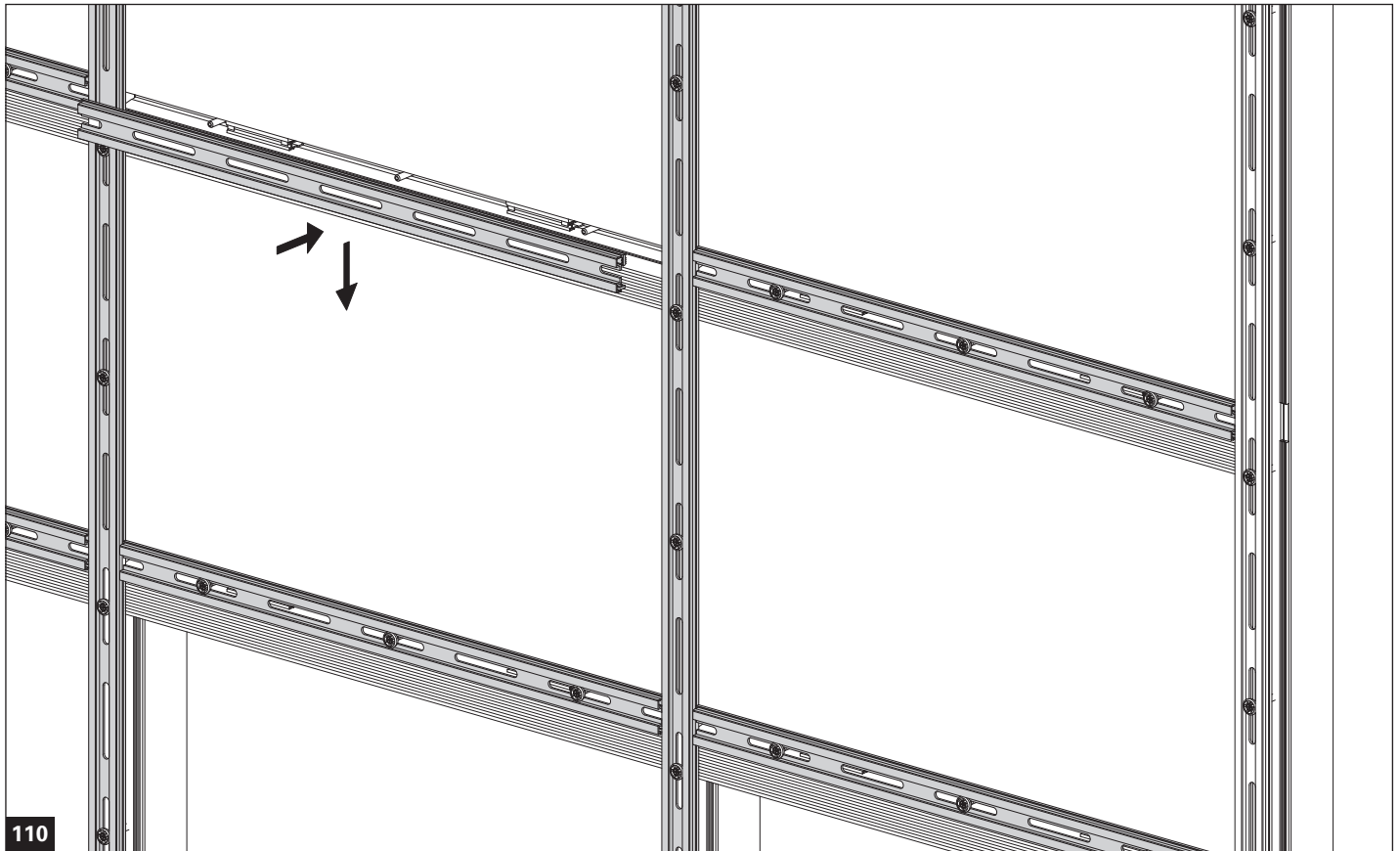

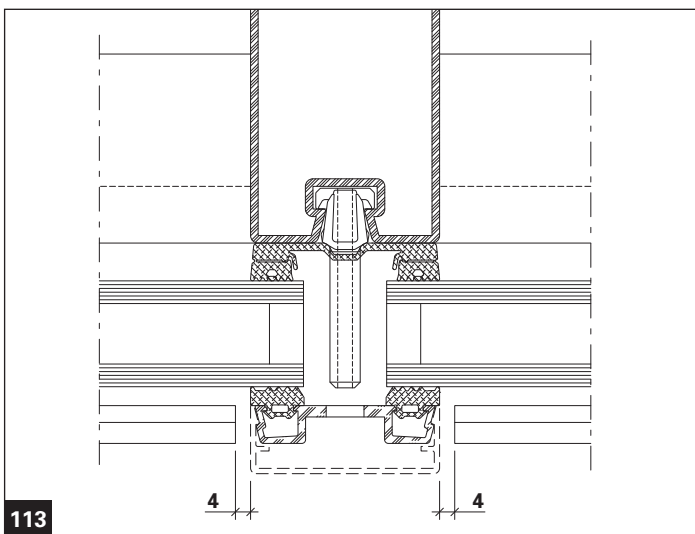
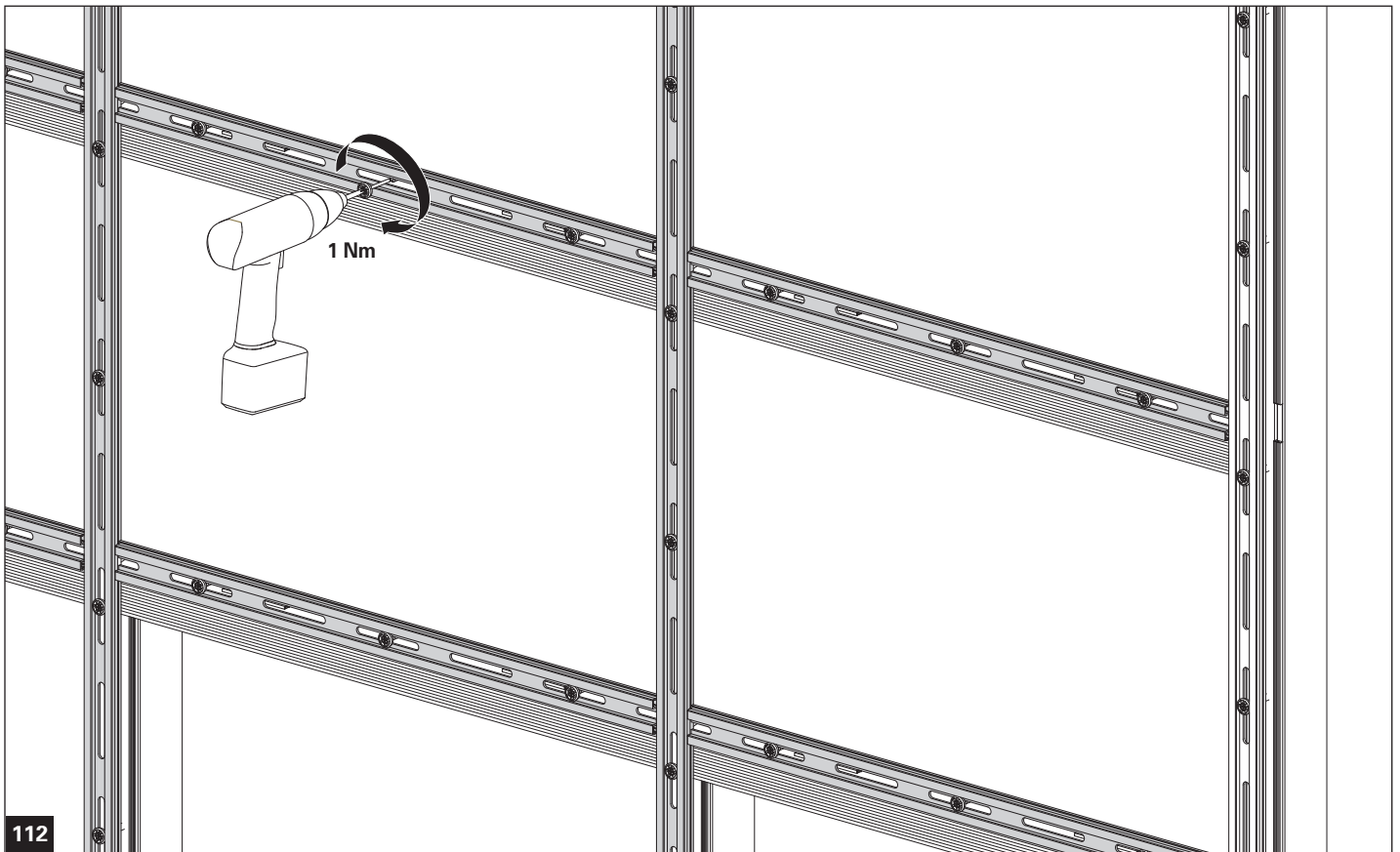

10.6 Montage Ausgleichsprofil für Bauanschluss  
 10.6 Montage du profilé de compensation pour raccord au mur

10.6 Installation of spacer profile for attachment to structure  
 10.6 Montaggio del profilo di tamponamento con l'opera in muratura

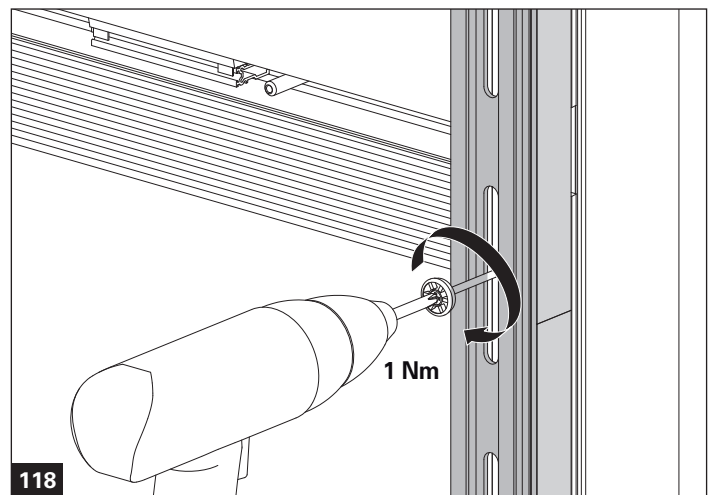
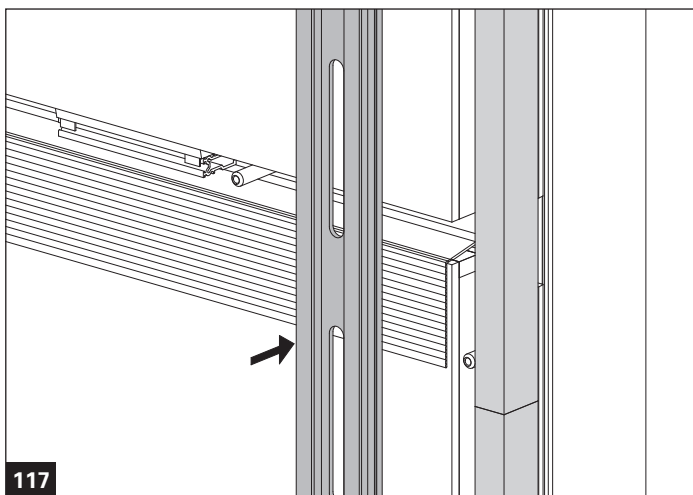
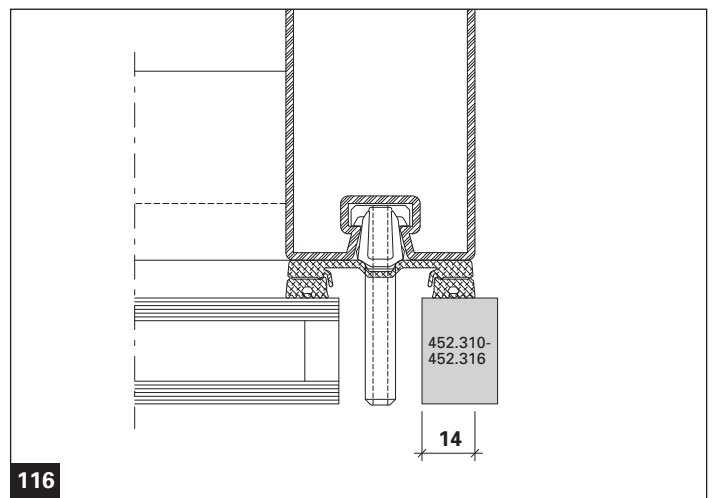
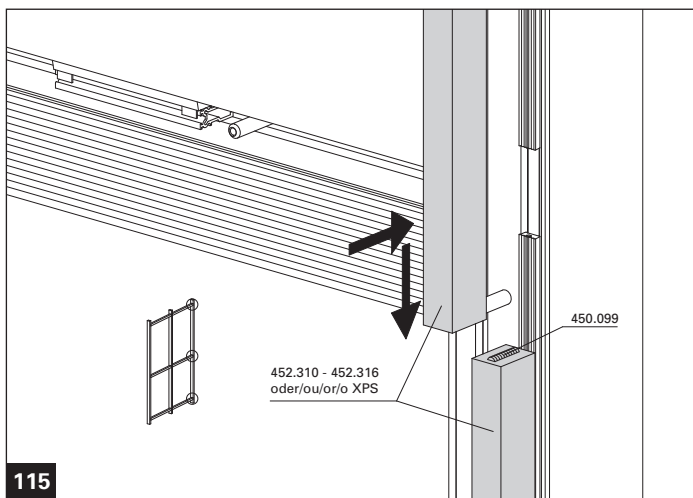
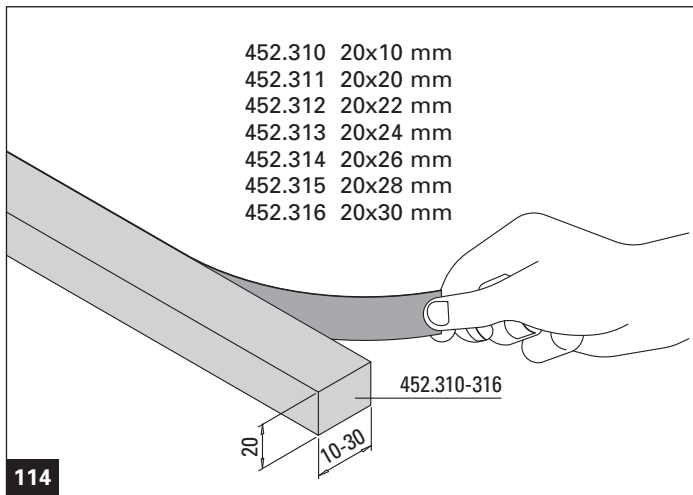

11. Einschneiden des Entwässerungslappens

11. Découpe de la lèvres de drainage

11. Cutting the draining lip to size

11. Taglio della linguetta drenaggio

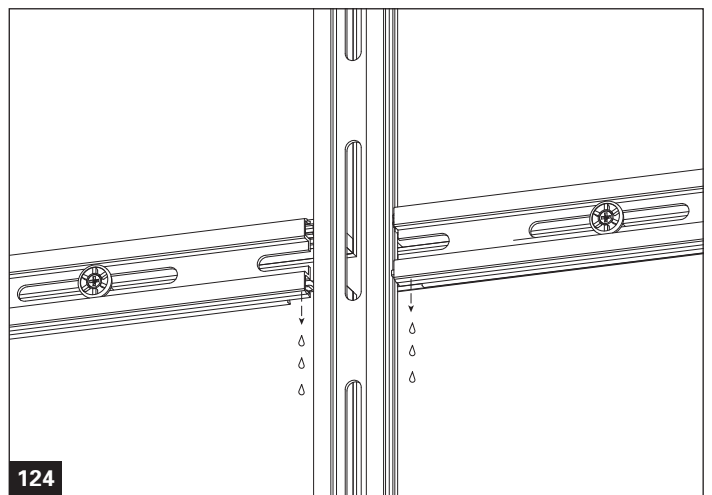
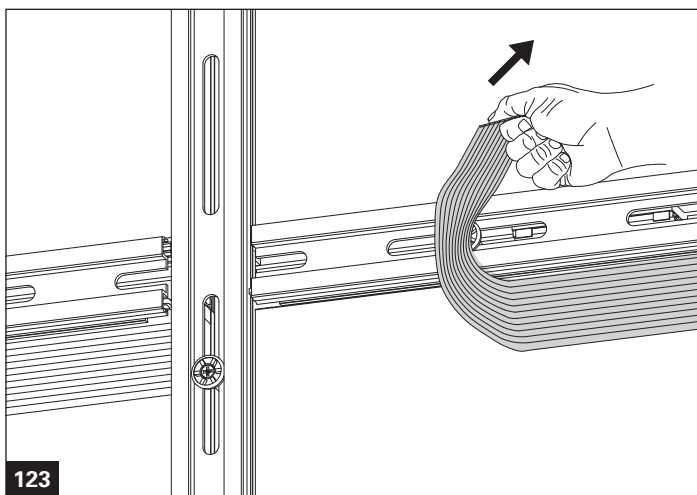
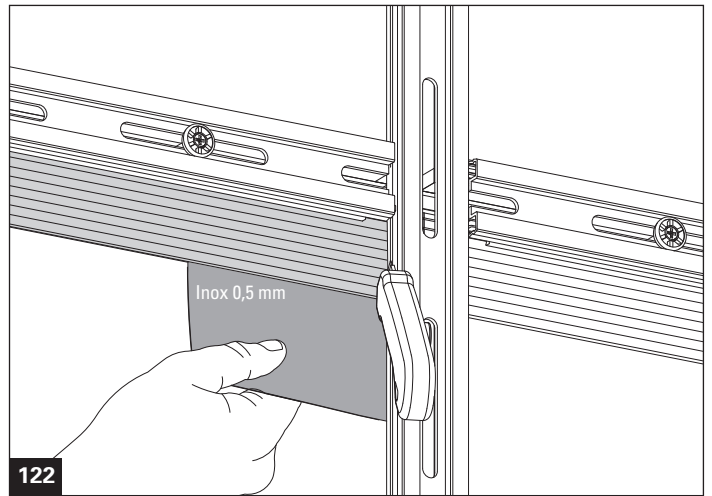
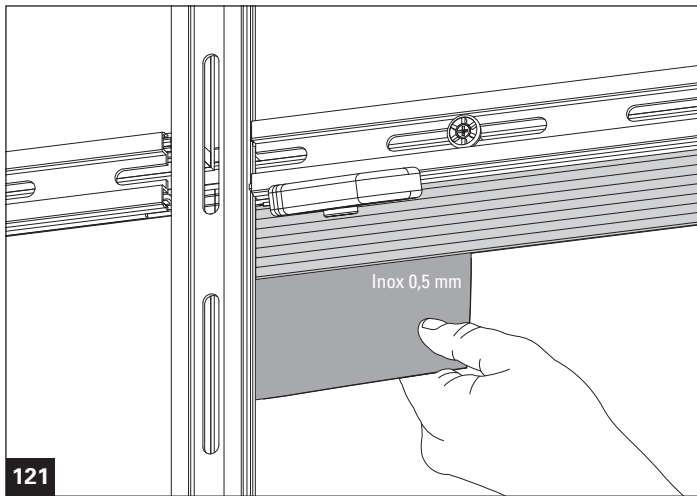
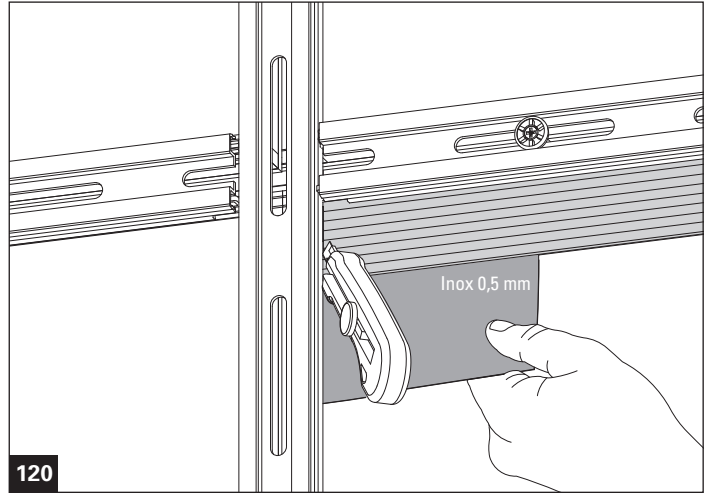
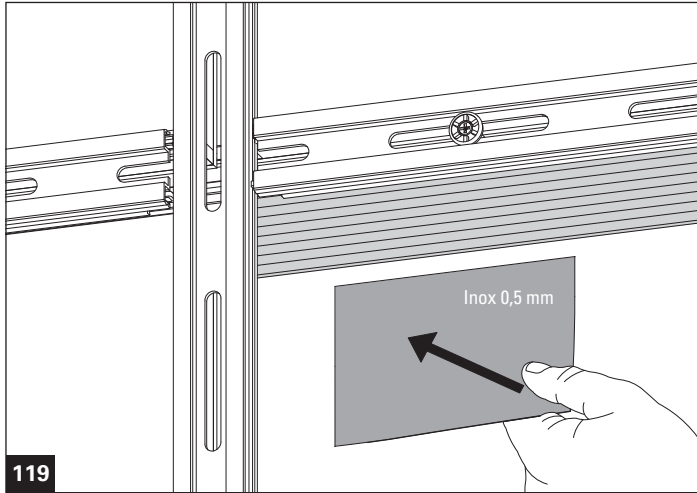



**12. Zuschnitt und Montage Abdeckprofile**

**12. Découpe et montage des profilés de recouvrement**

12.1 Vertikale Abdeckprofile

12.1 Profilés de recouvrement vertical

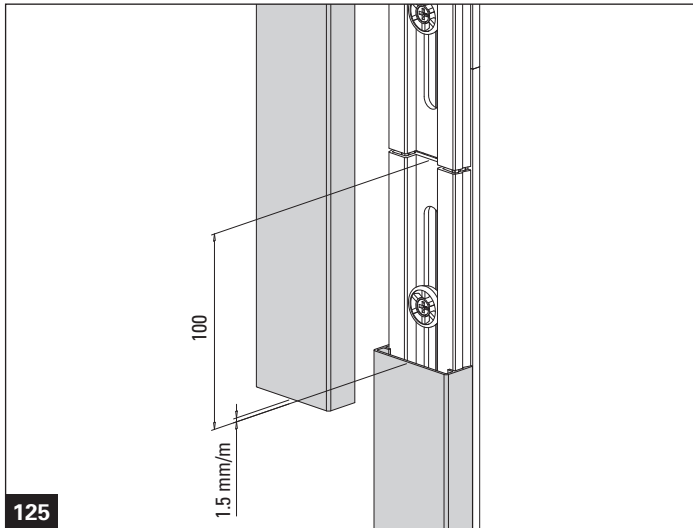

125

Deckprofilstoss vertikal

Joint de profilé de recouvrement vertical

Vertical cover section joint

Giunzione verticale della copertina esterna

**12. Cutting and assembly the cover sections**

**12. Taglio e montaggio delle copertine esterne**

12.1 Vertical cover sections

12.1 Copertine esterne verticale

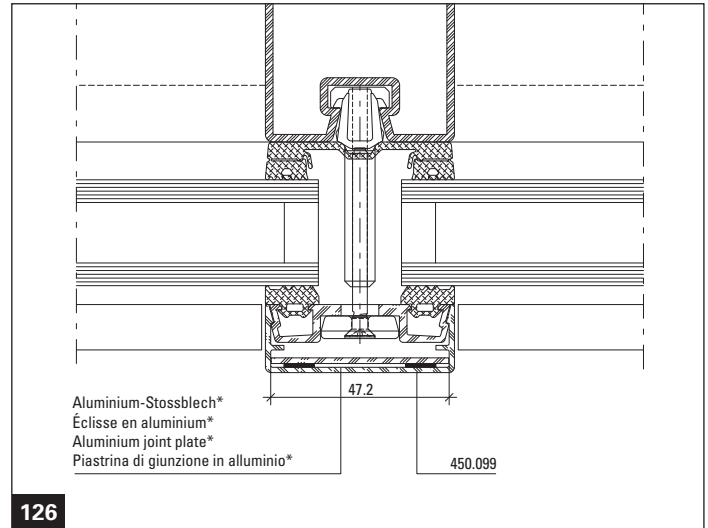

126

\* durch Metallbauer anzufertigen

\* fabriquer par le constructeur métallique

\* to be produced by metal fabricator

\* da realizzare a cura dell'azienda di costruzioni metalliche

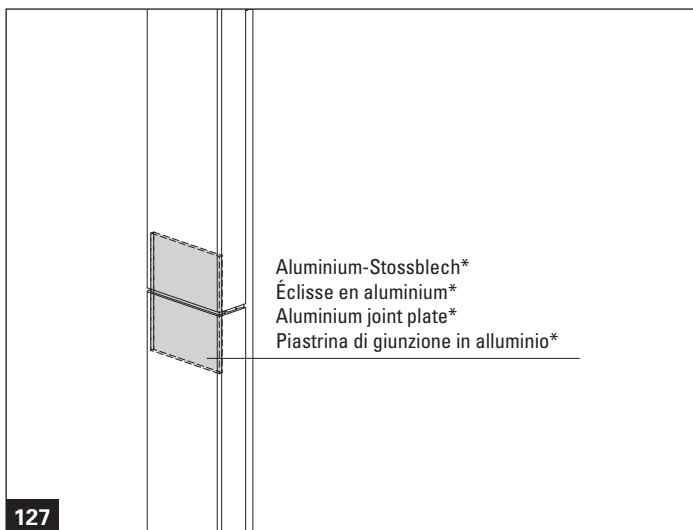

127

\* durch Metallbauer anzufertigen

\* fabriquer par le constructeur métallique

\* to be produced by metal fabricator

\* da realizzare a cura dell'azienda di costruzioni metalliche

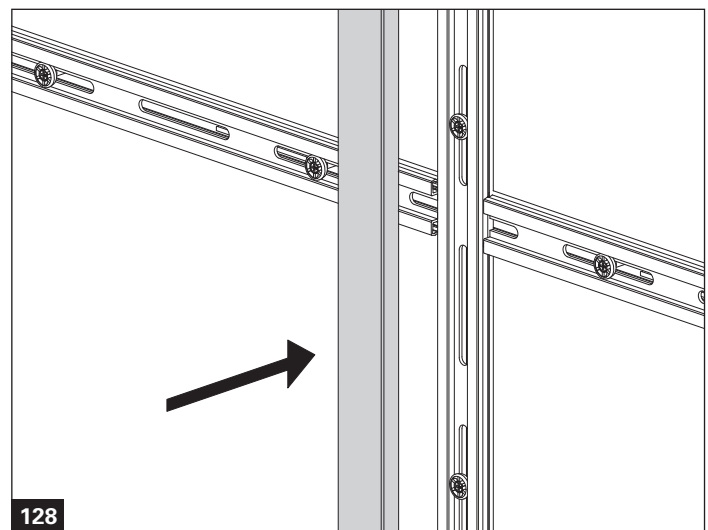

128

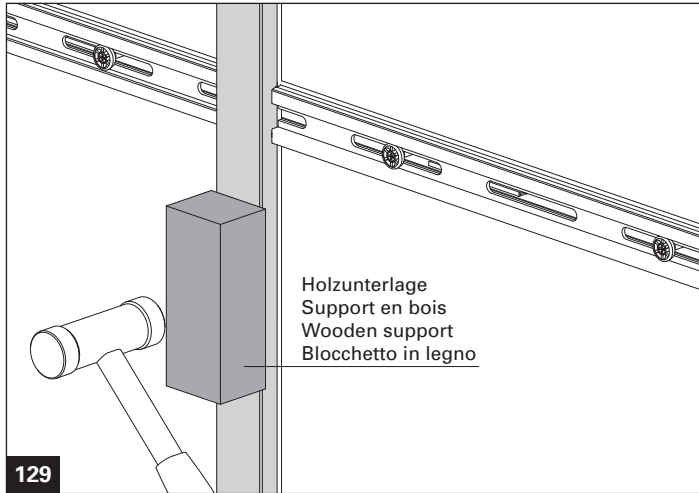

Abdeckprofile mit Nylonhammer und Holzunterlage vorsichtig aufschlagen

Enfoncer avec précaution les profilés de recouvrement avec un marteau à tête en nylon et un à tête en bois

Using a nylon hammer and wooden mallet, carefully strike the cover sections

Battere con cautela le copertine esterne usando il martello con testa in nylon e uno in legno

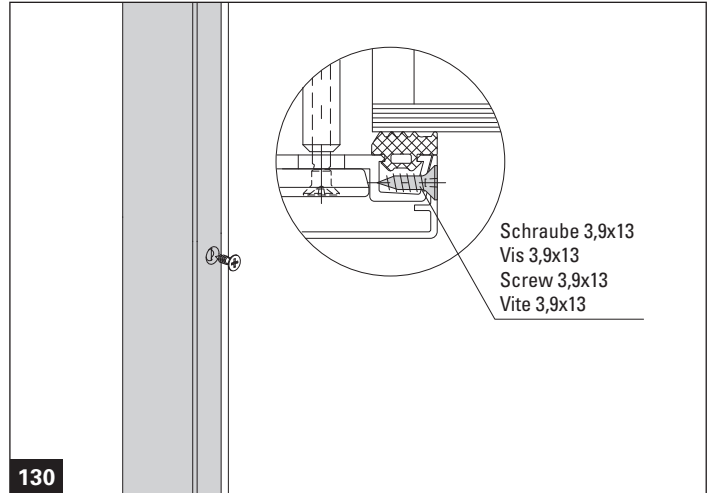

Sicherung Deckprofil – Häufigkeit und Abstand je nach bauseitiger Anforderung

Sécurité profilé de recouvrement – fréquence et intervalle en fonction des exigences sur le site

Securing the cover cap profile – Frequency and intervals according to site requirements

Blocco della copertina esterna – Frequenza e distanza in base ai requisiti stabiliti in loco

13.2 Horizontale Abdeckprofile  
 13.2 Profilés de recouvrement horizontale

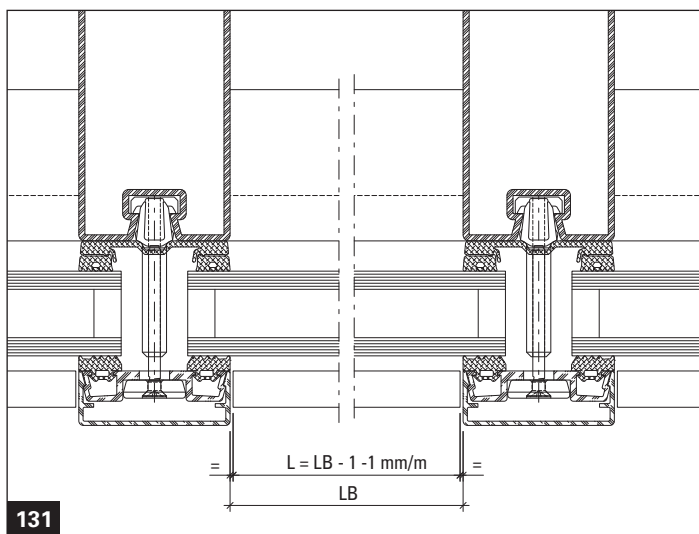

13.2 Horizontal cover sections  
 13.2 Copertine esterne orizzontale

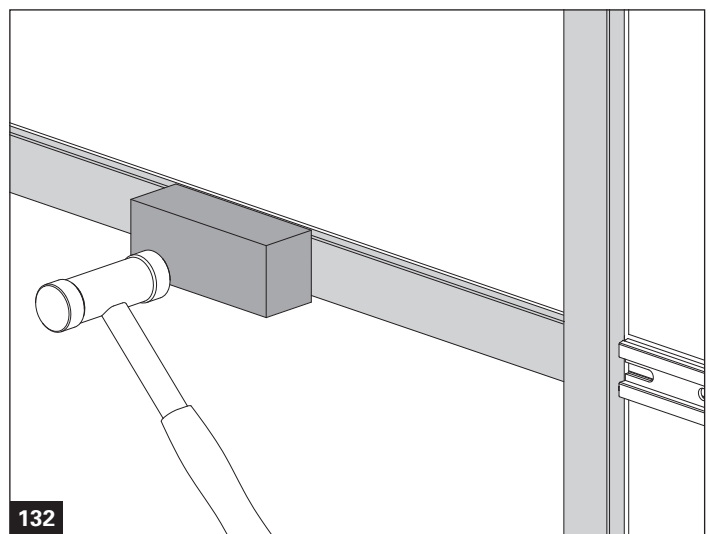

**13. Demontage der Abdeckprofile**

**13. Démontage des profilés de recouvrement**

**13. Dismantling the cover sections**

**13. Demontaggio copertina esterna**

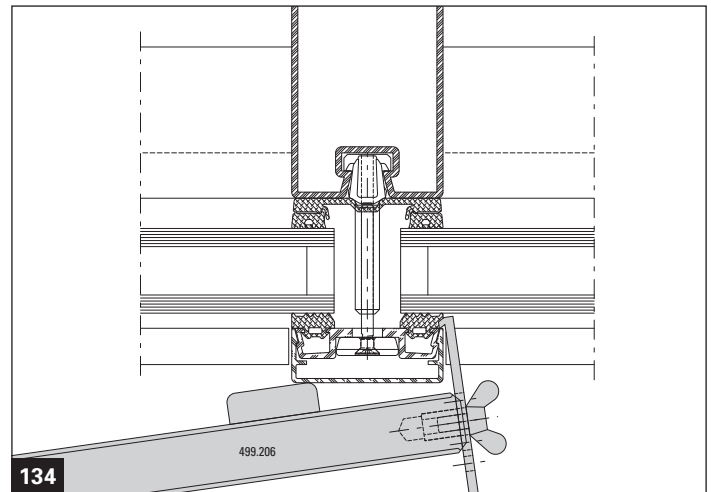
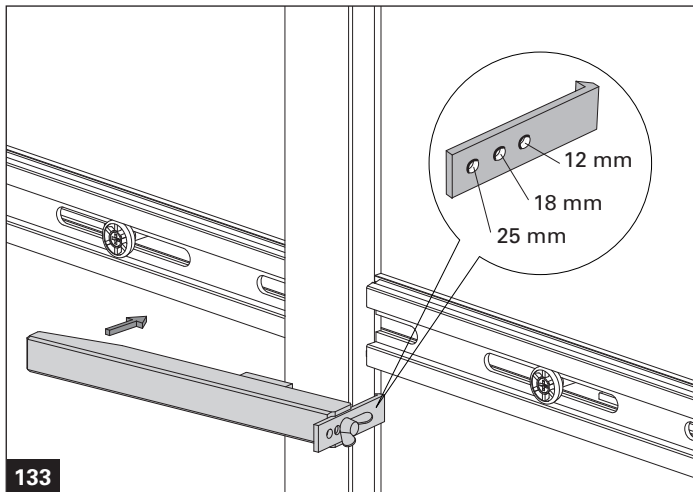

**14. Zuschnitt und Montage flaches Deckprofil**

**14. Découpe et montage profilé de recouvrement plat**

**14. Cutting and assembly flat cover cap**

**14. Taglio e montaggio copertina esterna piatta**

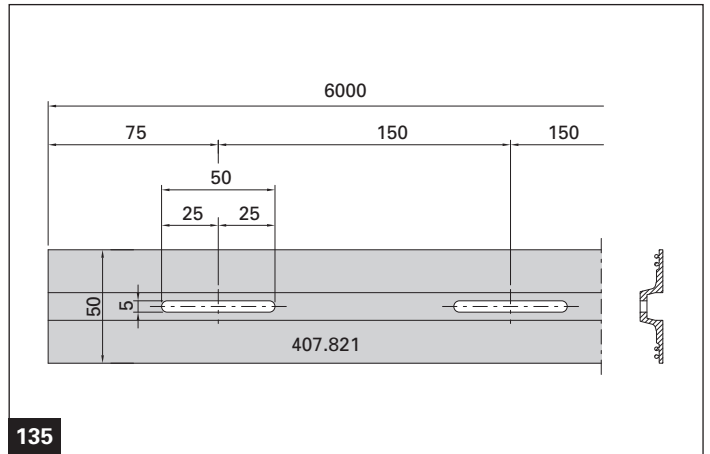
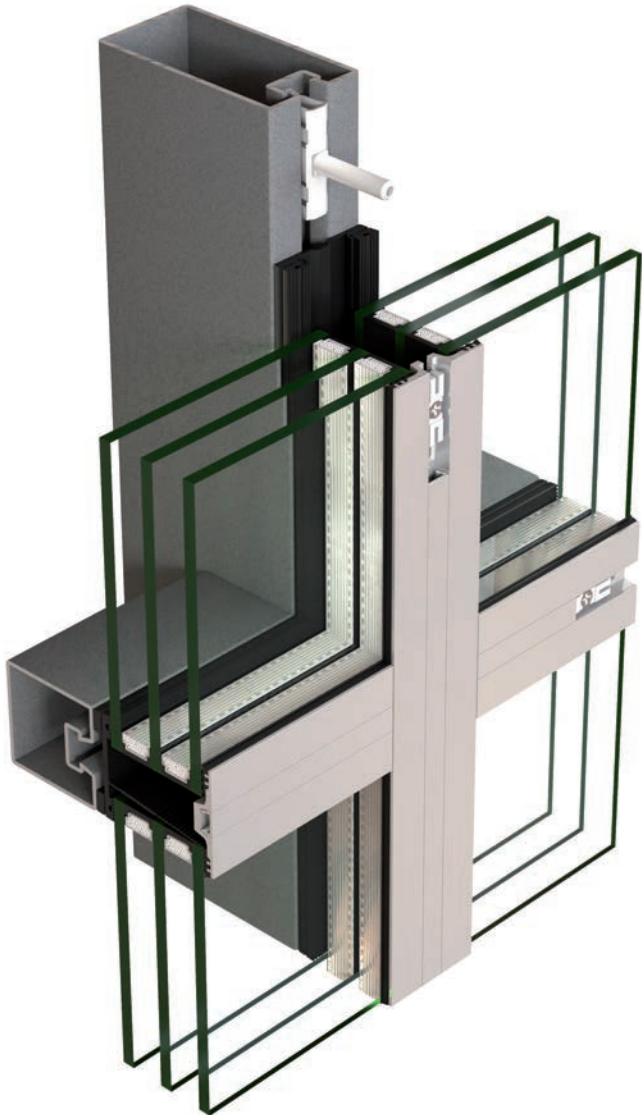

**135**

Das Anpressprofil 407.821 ist mit Langlöchern von 50x5 mm vorgestanzt

La profilé de fixation 407.821 est pré-poinçonnée avec des trous oblongs de 50x5 mm

The pressure plate 407.821 is pre-punched with 50x5 mm slots

Il profilo di fissaggio 407.821 è dotato di asole preforate da 50x5 mm

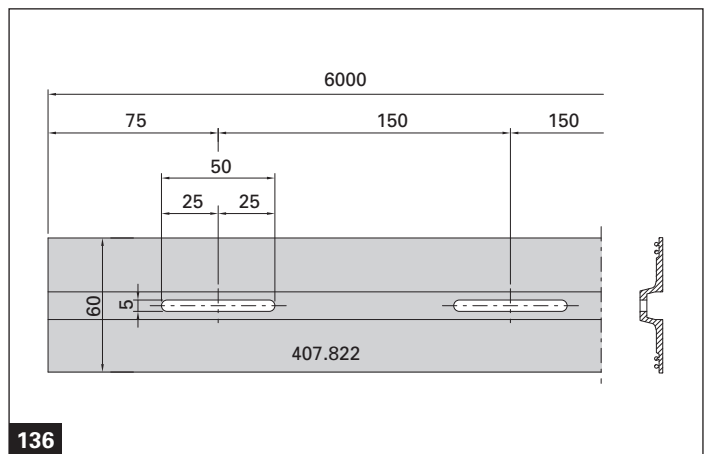

**136**

Das Anpressprofil 407.822 ist mit Langlöchern von 50x5 mm vorgestanzt

La profilé de fixation 407.822 est pré-poinçonnée avec des trous oblongs de 50x5 mm

The pressure plate 4'7.822 is pre-punched with 50x5 mm slots

Il profilo di fissaggio 407.822 è dotato di asole preforate da 50x5 mm

14.1 Zuschnitt Anpressprofil im Pfostenbereich  
 14.1 Découpe profilé de fixation dans la zone du montant

Die Stablänge des vertikalen Anpressprofils entspricht grundsätzlich der Pfostenlänge der Tragkonstruktion. Je nach Ausbildung des Boden- oder Deckenanschlusses sind allfällige Zuschläge oder Abzüge zu machen.

La longueur du profilé de fixation correspond toujours à celle du montant de la construction porteuse. Il doit être éventuellement procédé à des suppléments ou des déductions suivant la formation du raccord au plafond et du bas.

14.1 Cutting the pressure plate in the mullion area  
 14.1 Taglio del profilo di fissaggio in corrispondenza del montante

The bar length of the vertical pressure plate generally corresponds to the mullion length of the load-bearing structure. Depending on the design of the floor or ceiling connection, additions or subtractions may need to be made.

La lunghezza del profilo di fissaggio verticale corrisponde fondamentalmente alla lunghezza del montante della struttura portante. A seconda della conformazione del raccordo al pavimento o al soffitto si dovranno adottare eventuali maggiorazioni o riduzioni.

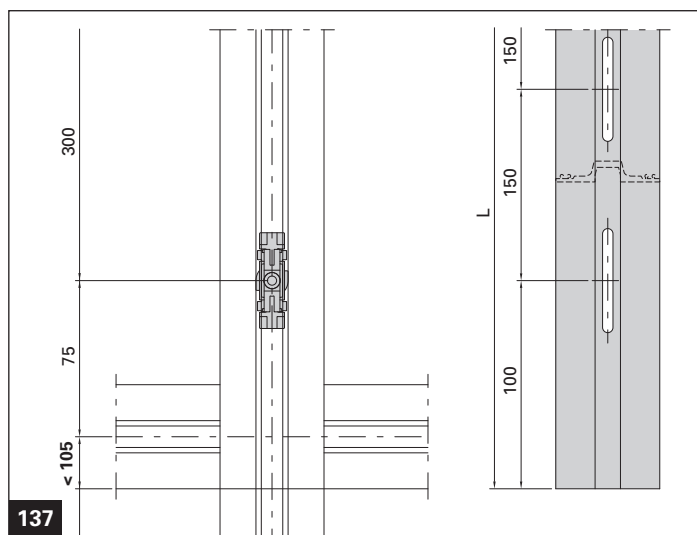

Zuschnitt-Beispiel für Fassade ohne Bodeneinstand  
 Exemple de découpe pour façade sans raccordement dans la chape  
 Cutting example for a façade without a floor recess  
 Esempio di taglio per facciata senza incasso a pavimento

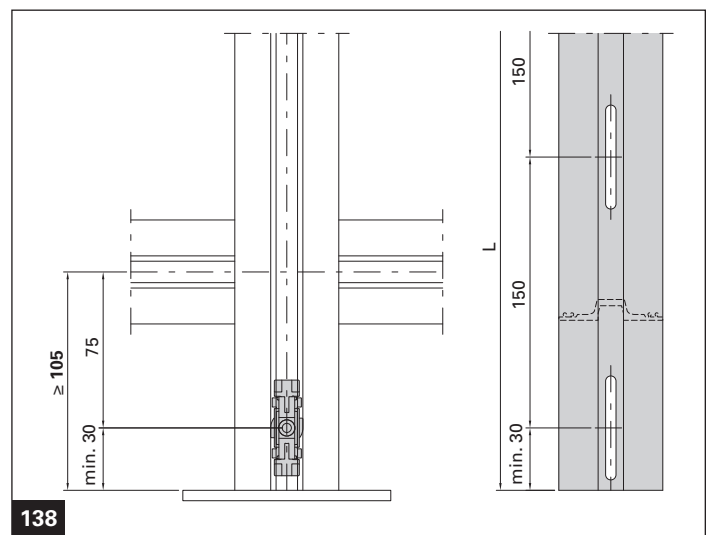

Zuschnitt-Beispiel für Fassade mit Bodeneinstand  
 Exemple de découpe pour façade avec raccordement dans la chape  
 Cutting example for a façade with a floor recess  
 Esempio di taglio per facciata con incasso a pavimento

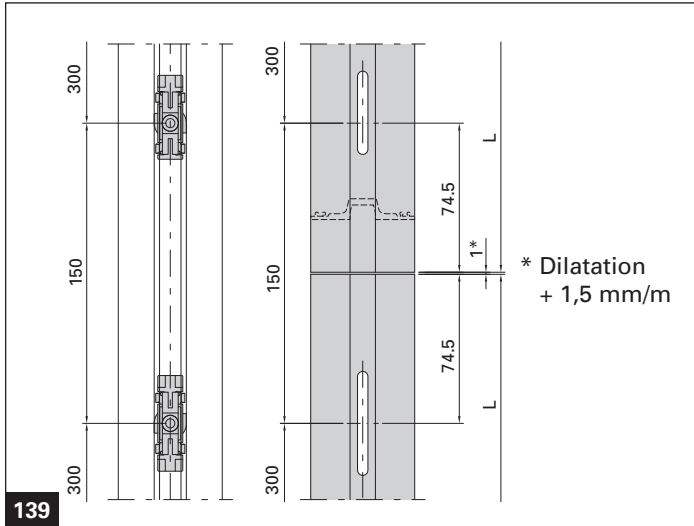

Der vertikale Profilstoss des Anpressprofils darf nicht im Riegelbereich ausgeführt werden.

La jonction verticale du profilé de fixation ne doit pas être exécutée dans la zone de la traverse.

The vertical profile joint of the pressure plate must not be in the transom area.

La giunzione verticale del profilo di fissaggio non deve essere realizzata in corrispondenza del traverso.

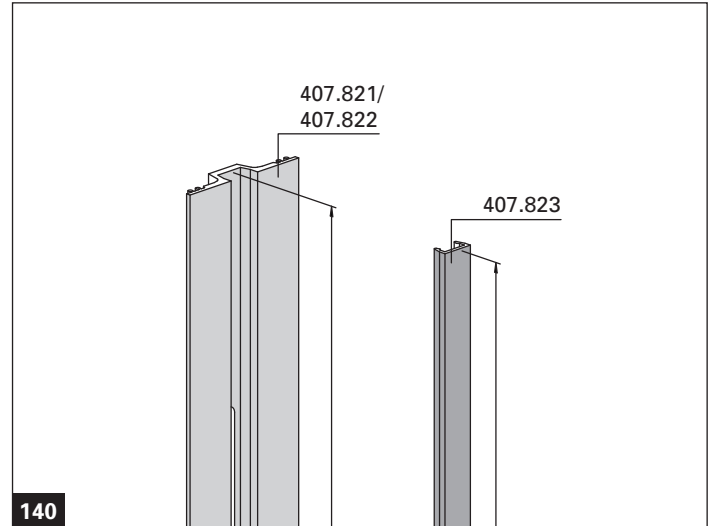

Die Zuschnittlänge des Abdeckprofils 407.823 beim Pfosten entspricht der Länge des Anpressprofils 407.821/407.822

La longueur de découpe du profilé de recouvrement 407.823 dans la zone du montant correspond à celle du profilé de fixation 407.821/407.822

The cutting length of the cover profile 407.823 for the mullion corresponds to the length of the pressure plate 407.821/407.822

La lunghezza di taglio della copertina esterna 407.823 sul montante corrisponde a quella del profilo di fissaggio 407.821/407.822

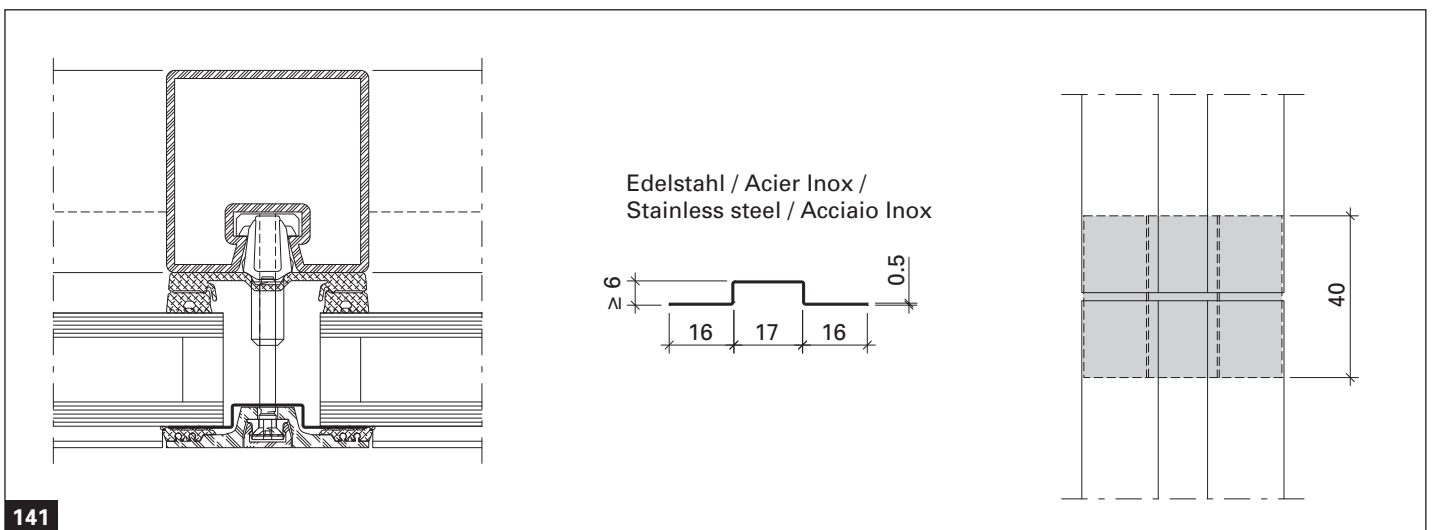

Das Stossblech für den Dilatations-Stoss ist durch den Metallbauer zu fertigen.

L'éclisse du joint de dilatation doit être réalisée par le constructeur métallique.

The T-support for the expansion joint must be fabricated by the metal fabricator.

La piastrina di giunzione per il giunto di dilatazione deve essere realizzata dall'azienda di costruzioni metalliche.

14.2 Zuschnitt Anpressprofil im Riegelbereich  
 14.2 Découpe profilé de fixation dans la zone de la traverse

14.2 Cutting the pressure plate in the transom area  
 14.2 Taglio del profilo di fissaggio in corrispondenza del traverso

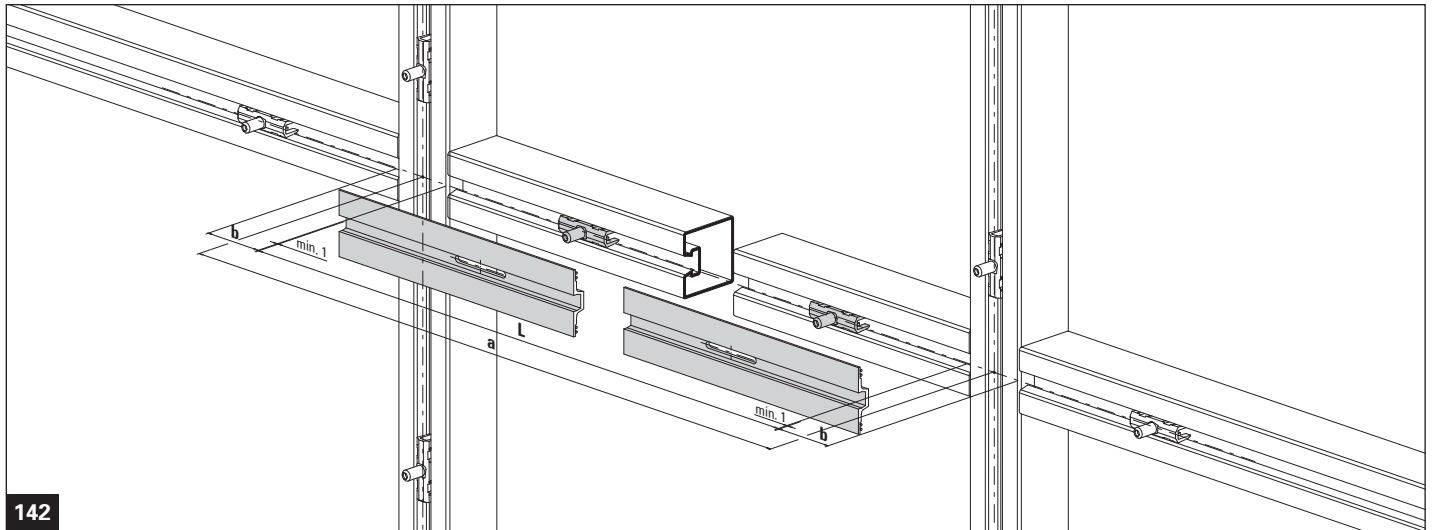

142

Berechnung Zuschnitt-Länge:  $L = a - b - 2 \text{ mm} (-1 \text{ mm/m})$   
 Calcul longueur de découpe:  $L = a - b - 2 \text{ mm} (-1 \text{ mm/m})$   
 Calculation of the cutting length:  $L = a - b - 2 \text{ mm} (-1 \text{ mm/m})$   
 Calcolo della lunghezza di taglio:  $L = a - b - 2 \text{ mm} (-1 \text{ mm/m})$

**Beispiel / Exemple / Example / Esempio:**  $L = 920 - 50 - 2 = 868 \text{ mm}$

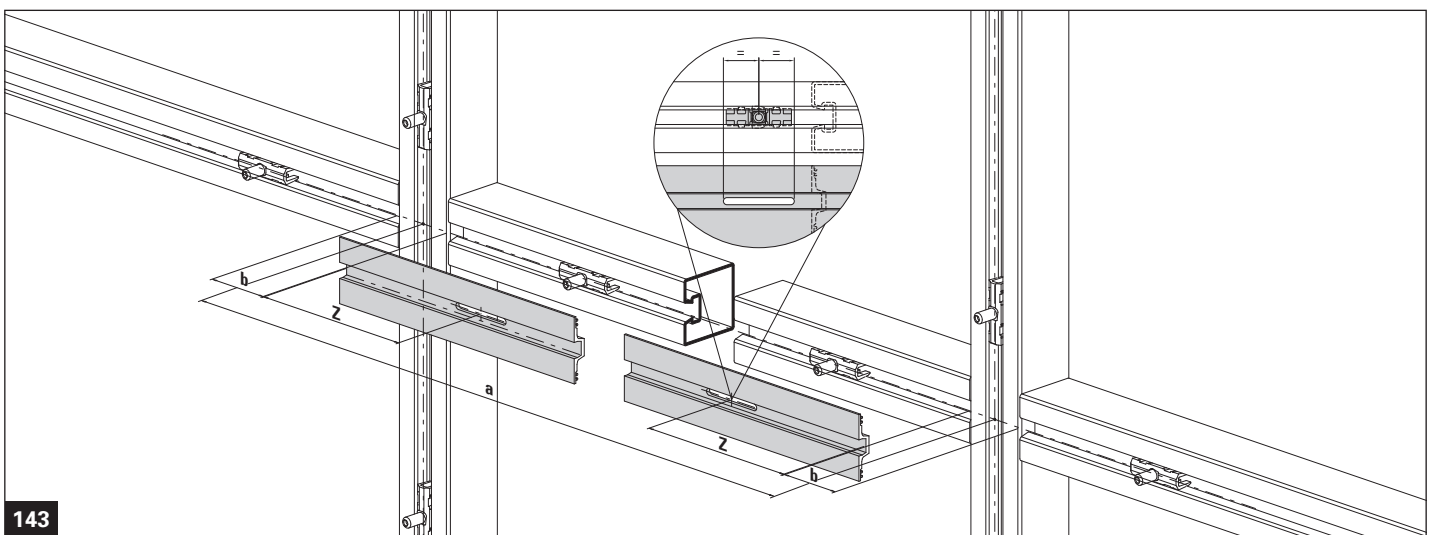

143

Berechnung des Anschnittes Z:  $Z = (a - 200) / 150 = \text{Ergebnis}$   
 Kommastellen von Ergebnis  $\times 75 + 99 - (b/2)$   
 Calcul de l'attaque Z:  $Z = (a - 200) / 150 = \text{Résultat}$   
 Virgule décimale du résultat  $\times 75 + 99 - (b/2)$   
 Calculation of cut Z:  $Z = (a - 200) / 150 = \text{Result}$   
 Decimal point from result  $\times 75 + 99 - (b/2)$   
 Calcolo della quota Z:  $Z = (a - 200) / 150 = \text{Risultato}$   
 decimali del risultato  $\times 75 + 99 - (b/2)$

**Beispiel / Exemple / Example / Esempio:**  $Z = (920 - 200) / 150 = 4,8$   
 $0,8 \times 75 + 99 - (50/2) = 134$

14.3 Zuschnitt Abdeckprofil  
 14.3 Découpe profilé de recouvrement

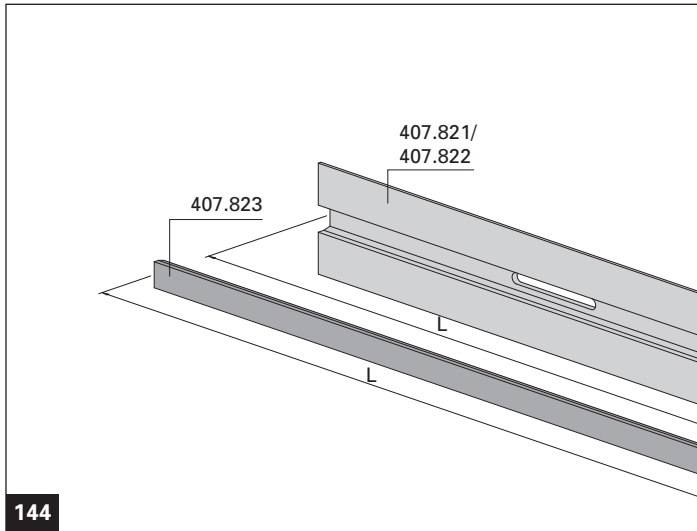

Die Zuschnittlänge des Abdeckprofils 407.823 im Riegelbereich entspricht der Länge des Anpressprofils 407.821/407.822

La longueur de découpe du profilé de recouvrement 407.823 dans la zone de la traverse correspond à celle du profilé de fixation 407.821/407.822

The cutting length of the cover profile 407.823 in the transom area corresponds to the length of the pressure plate 407.821/407.822

La lunghezza di taglio della copertina esterna 407.823 nell'area del traverso corrisponde a quella del profilo di fissaggio 407.821/407.822

14.3 Cutting the cover profile  
 14.3 Taglio della copertina esterna

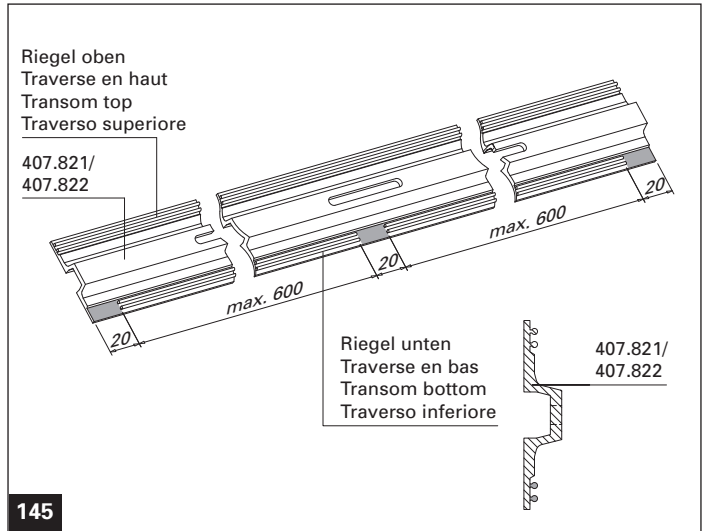

Ausklinkungen bei Riegel-Anpressprofil 407.821/407.822

Entailles dans le profilé de fixation de la traverse 407.821/407.822

Notching the transom pressure plate 407.821/407.822

Intagli sul profilo di fissaggio del traverso 407.821/407.822



14.4 Zuschnitt Dichtungen  
 14.4 Découpe joints

14.4 Cutting the gaskets  
 14.4 Taglio delle guarnizioni

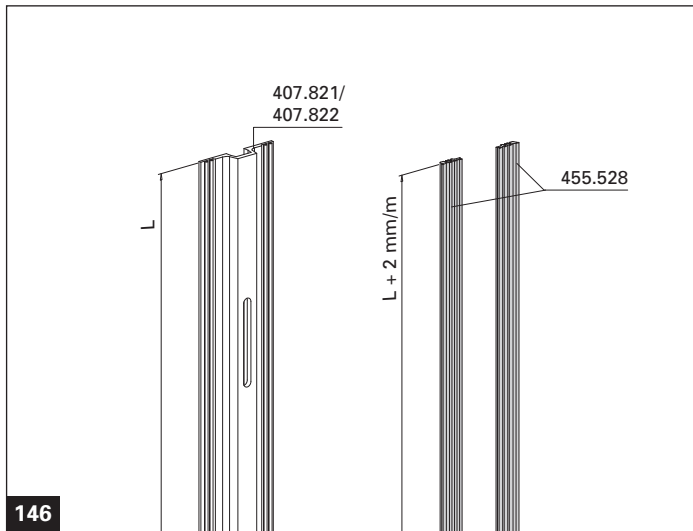

Zuschnitt der vertikalen Dichtung im Pfostenbereich  
 Découpe du joint vertical dans la zone du montant  
 Cutting the vertical gasket in the mullion area  
 Taglio della guarnizione verticale in corrispondenza del montante

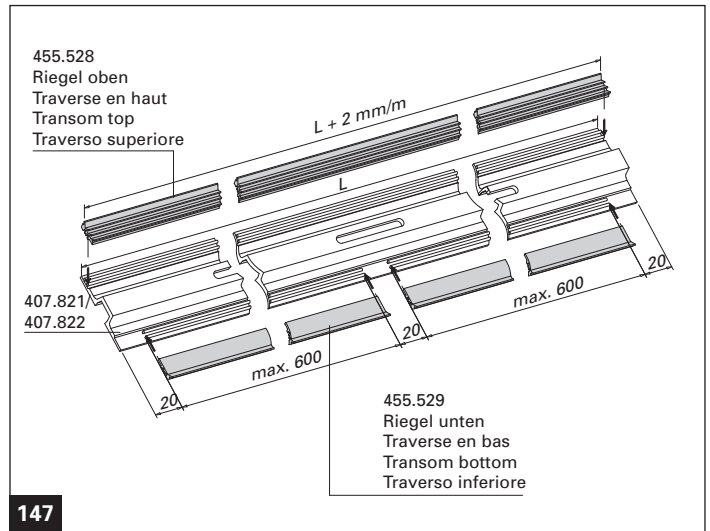

Zuschnitt der horizontalen Dichtung im Riegelbereich  
 Découpe du joint horizontal dans la zone de la traverse  
 Cutting the horizontal gasket in the transom area  
 Taglio della guarnizione orizzontale in corrispondenza del traverso

14.5 Montage Dichtungen auf Anpressprofil  
 14.5 Montage des joints sur le profilé de fixation

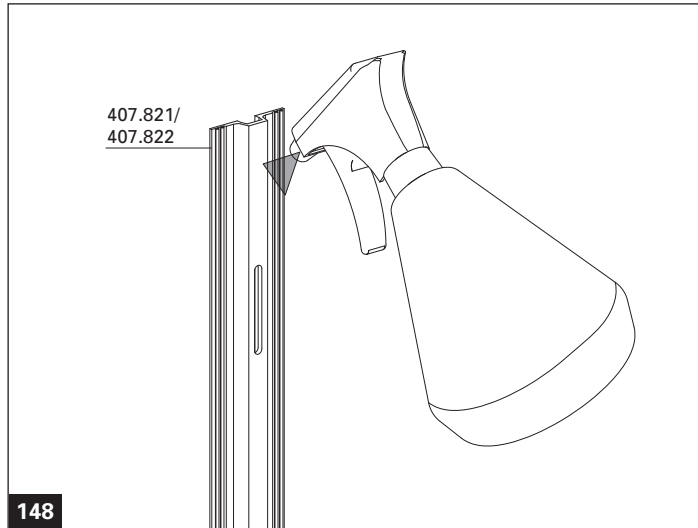

Anpressprofil mit Seifenwasser besprühen  
 Asperger de l'eau savonneuse sur le profilé de fixation  
 Spray the pressure plate with soapy water  
 Spruzzare il profilo di fissaggio con dell'acqua saponata

14.5 Installing the gaskets on the pressure plate  
 14.5 Montaggio delle guarnizioni sul profilo di fissaggio

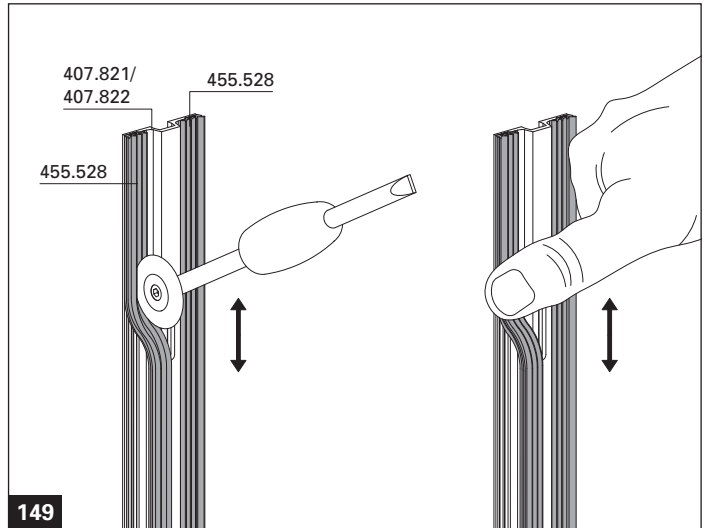

Dichtung ohne Zug eindrücken  
 Presser le joint à l'intérieur sans opérer de traction  
 Press the gasket in without tension  
 Comprimer la guarnizione in sede senza esercitare alcuna trazione

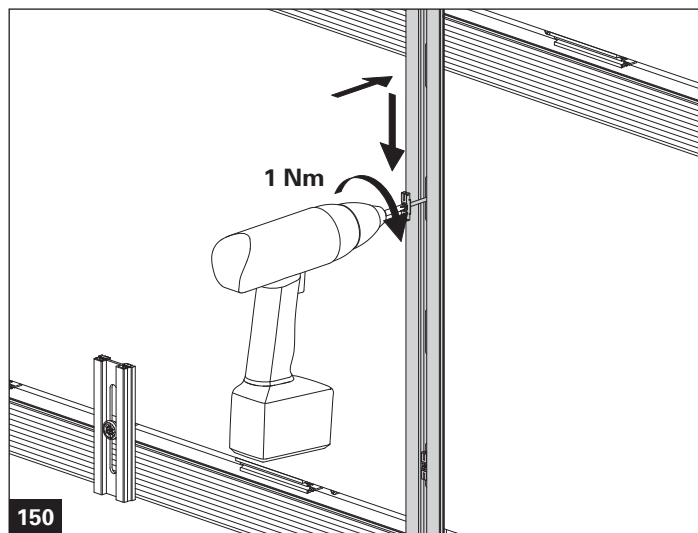

Montage des Anpressprofils 407.821/407.822 im Pfostenbereich  
 Montage du profilé de fixation 407.821/407.822 dans la zone du montant  
 Installing the pressure plate 407.821/407.822 in the mullion area  
 Montaggio del profilo di fissaggio 407.821/407.822 in corrispondenza del montante

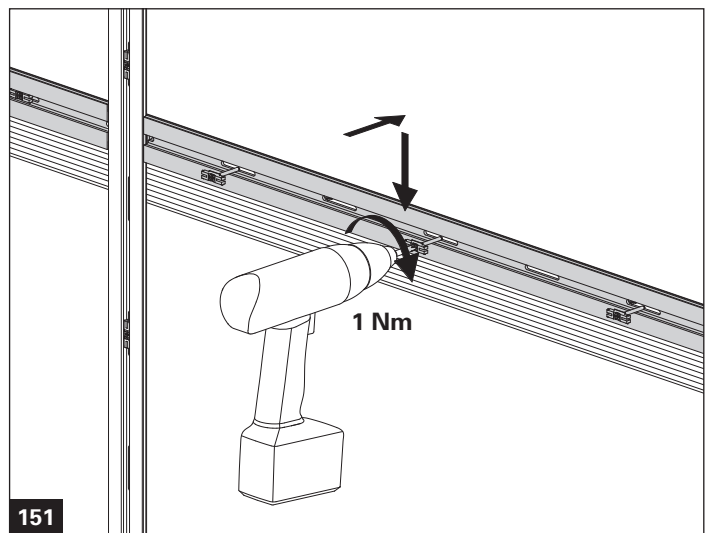

Montage des Anpressprofils 407.821/407.822 im Riegelbereich  
 Montage du profilé de fixation 407.821/407.822 dans la zone de la traverse  
 Installing the pressure plate 407.821/407.822 in the transom area  
 Montaggio del profilo di fissaggio 407.821 /407.822 in corrispondenza del traverso

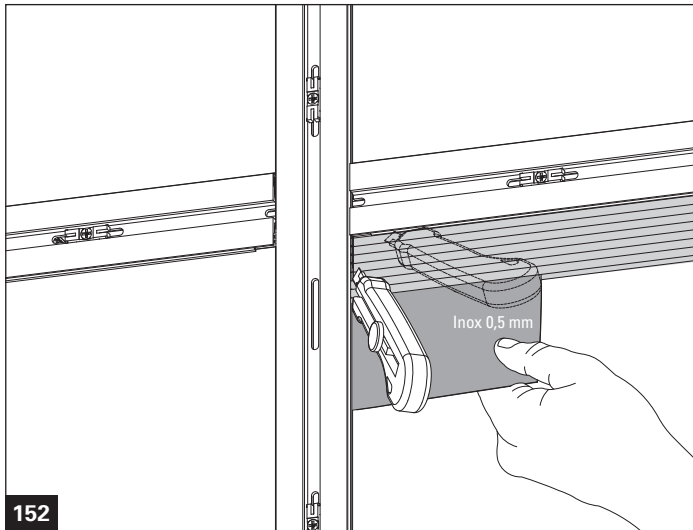

Dichtungslappen der Riegel-Innendichtung seitlich und oben einschneiden  
 Entailler les lèvres d'étanchéité du joint intérieur de la traverse sur le côté et en haut  
 Cut into the gasket lip of the transom internal gasket at the side and top  
 Tagliare i labbri della guarnizione interna del traverso sia di lato che in alto

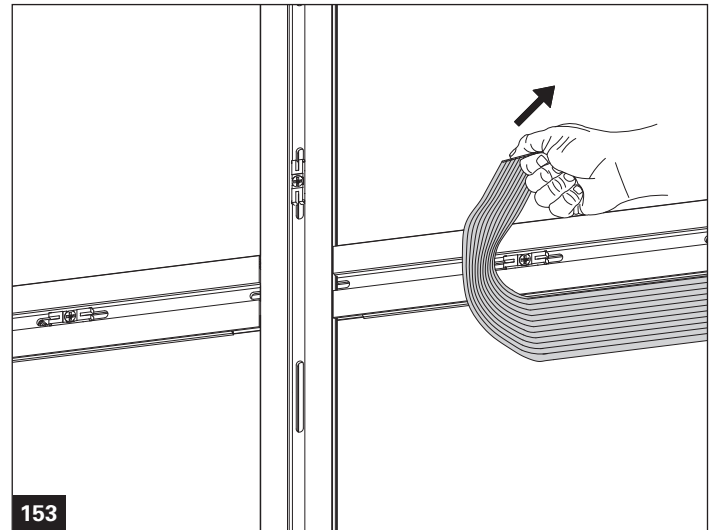

Dichtungslappen abreißen  
 Arracher les lèvres d'étanchéité  
 Tear off the gasket lip  
 Staccare i labbri della guarnizione

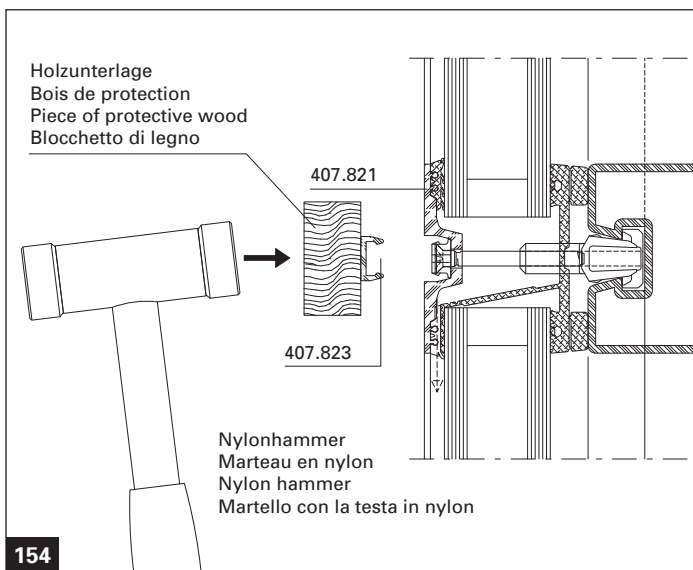

Montage des Abdeckprofile 407.823  
 Montage du profilé de recouvrement 407.823  
 Installing the cover profile 407.823  
 Montaggio della copertina esterna 407.823

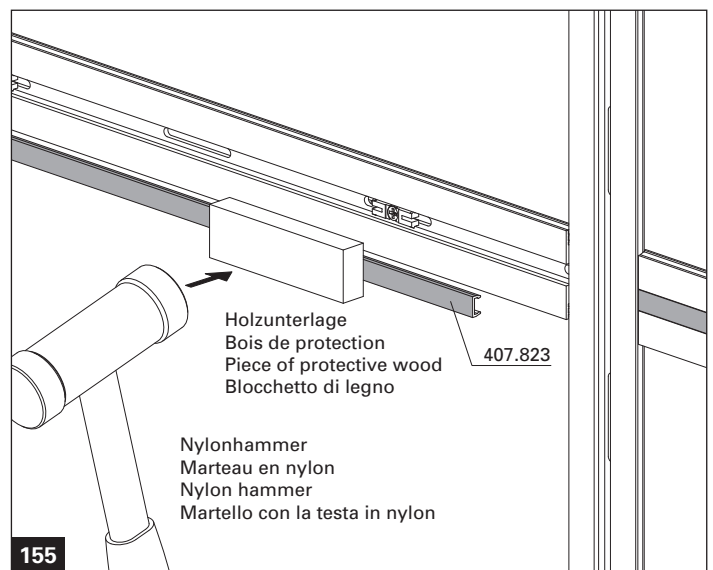

Holzunterlage  
 Bois de protection  
 Piece of protective wood  
 Blocchetto di legno  
 407.823  
 Nylonhammer  
 Marteau en nylon  
 Nylon hammer  
 Martello con la testa in nylon

*Profile 50 mm*  
*Profilés 50 mm*  
*Profiles 50 mm*  
*Profili 50 mm*

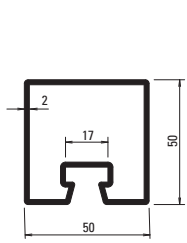

**76.694**  
**76.694 Z**

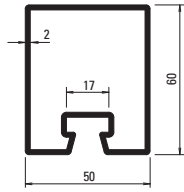

**76.671**  
**76.671 Z**

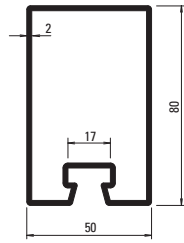

**76.696**  
**76.696 Z**

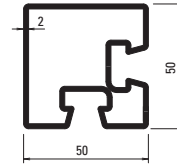

**76.094**  
**76.094 GV+GC**

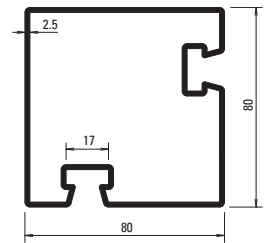

**76.096**  
**76.096 GV+GC**

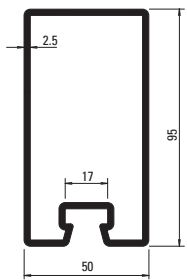

**76.697**  
**76.697 Z**

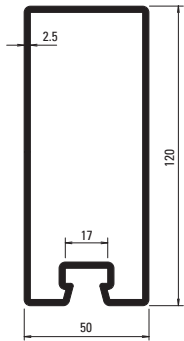

**76.679**  
**76.679 Z**

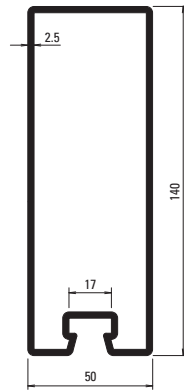

**76.666**  
**76.666 Z**

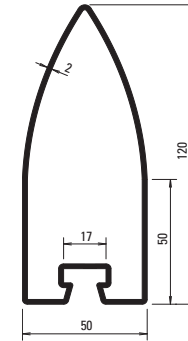

**76.105**  
**76.105 GV+GC**

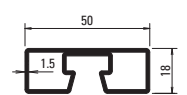

**76.692**  
**76.692 GV+GC**

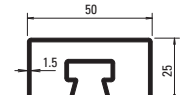

**76.682**  
**76.682 GV+GC**

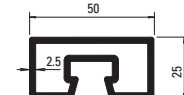

**76.680**  
**76.680 GV+GC**

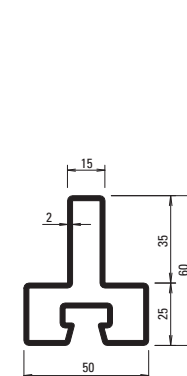

**76.114**  
**76.114 GV+GC**

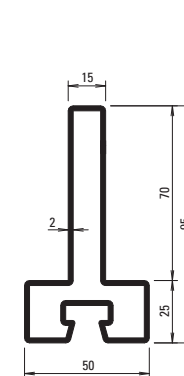

**76.115**  
**76.115 GV+GC**

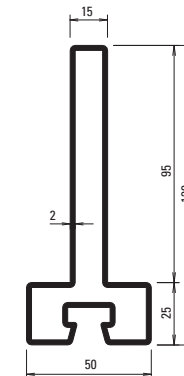

**76.116**  
**76.116 GV+GC**

Profile 60 mm  
 Profilés 60 mm  
 Profiles 60 mm  
 Profili 60 mm

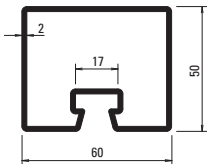

**76.695**  
**76.695 Z**

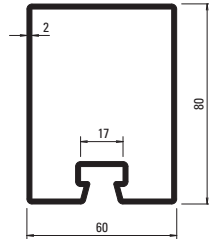

**76.678**  
**76.678 Z**

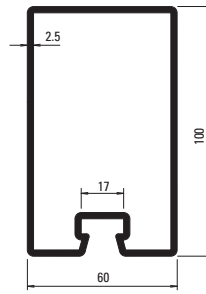

**76.684**  
**76.684 Z**

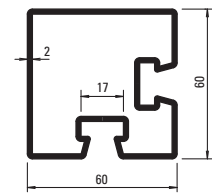

**76.095**

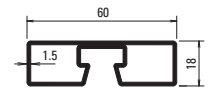

**76.693**

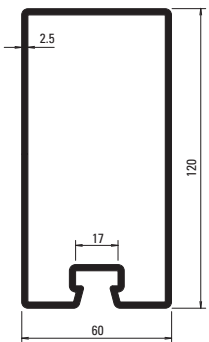

**76.698**  
**76.698 Z**

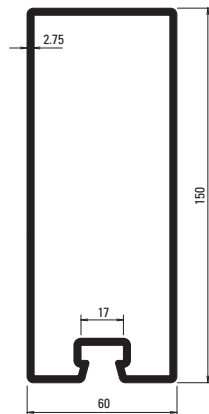

**76.667**  
**76.667 Z**

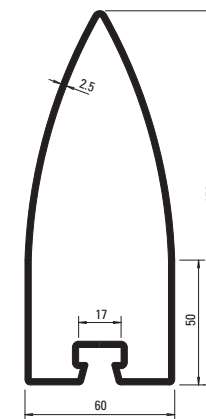

**76.100**

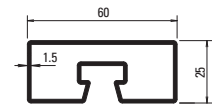

**76.683**

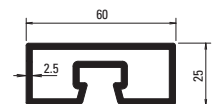

**76.681**

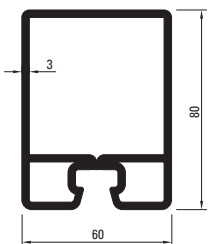

**76.143 Z**

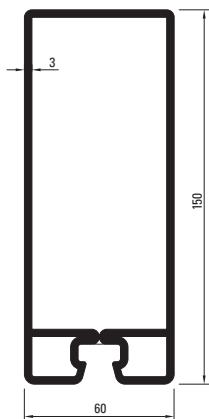

**76.144 Z**

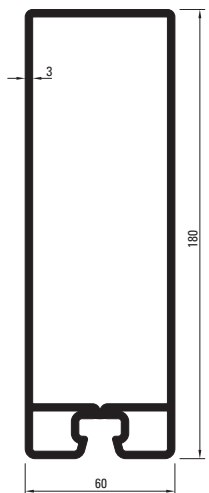

**76.140 Z**

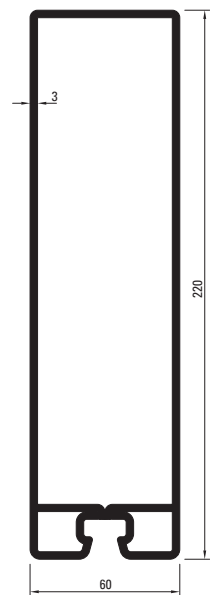

**76.141 Z**

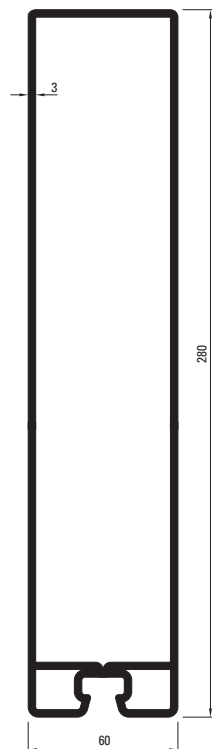

**76.142 Z**

*Deckprofile 50 mm*  
*Profilé de recouvrement 50 mm*

*Cover sections 50 mm*  
*Copertine esterne 50 mm*

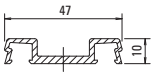

**407.800**

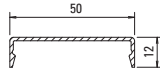

**407.860**

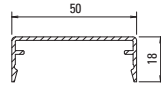

**407.861**

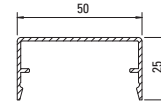

**407.862**

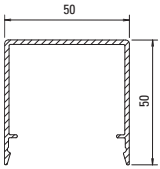

**407.863**

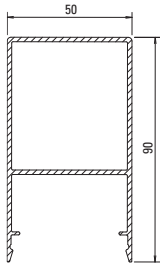

**407.864**

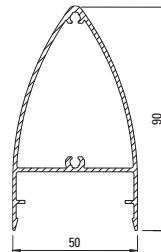

**407.914**

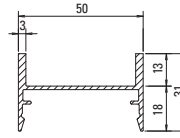

**407.900**

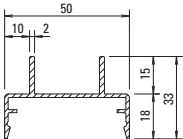

**407.911**

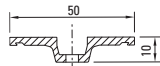

**407.821**



**407.823**

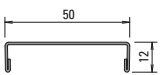

**400.860**

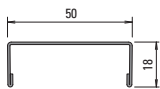

**400.861**

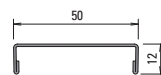

**400.862**

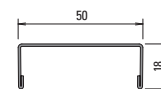

**400.863**



*Deckprofile 60 mm*  
*Profilé de recouvrement 60 mm*

*Cover sections 60 mm*  
*Copertine esterne 60 mm*

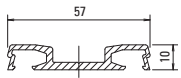

**407.802**

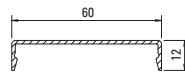

**407.865**

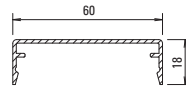

**407.866**

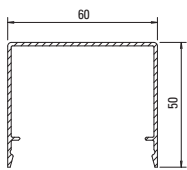

**407.868**

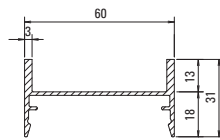

**407.901**

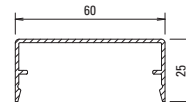

**407.867**

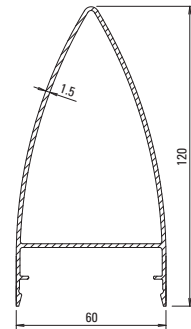

**407.915**

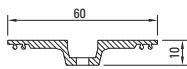

**407.822**



**407.823**



455.537



455.501



455.558



455.502



455.505



455.538



455.528



455.559



455.529

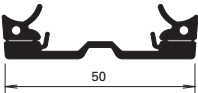

455.545

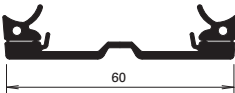

455.546





452.499

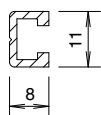

407.809

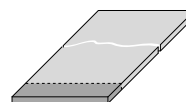

453.078



452.410  
 452.411  
 452.412  
 452.464  
 452.465  
 452.466

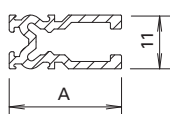

407.808  
 407.809  
 407.810  
 407.811  
 407.812  
 407.813

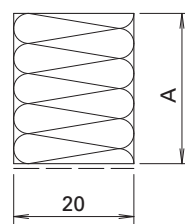

452.310  
 452.311  
 452.312  
 452.313  
 452.314  
 452.315  
 452.316



452.410  
 452.411  
 452.412



453.013



450.099



452.473



453.002  
 453.003  
 453.004  
 453.010



450.095



452.469  
 452.470  
 452.471

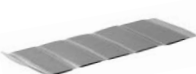

455.423  
 455.424



455.495  
 455.496



499.003



499.254



499.206



499.264



499.266



499.267



499.262

---

VISS Fassade  
VISS façade  
VISS façade  
VISS facciate

---

Jansen AG

**Steel Systems**  
Industriestrasse 34  
9463 Oberriet  
Schweiz  
[jansen.com](http://jansen.com)

**JANSEN**  
Configure to Inspire