

VISS Fire EI30

Lieferprogramm

VISS Fire EI30

Programme de livraison

VISS Fire EI30

Sales range

Hinweise
Remarque
Notice

Jansen Stahlssysteme
Systèmes en acier Jansen
Jansen Steel Systems

Lieferprogramm
VISS Fire EI30

Programme de livraison
VISS Fire EI30

Sales range
VISS Fire EI30

Version 06/2020
Artikelnummer K1192248

Version 06/2020
Numéro d'article K1192248

Version 06/2020
Item number K1192248

Eine Liste der aktuellen Änderungen und Ergänzungen finden Sie am Ende des Kataloges!

Une liste des dernières modifications et ajouts est disponible à la fin du catalogue!

A table of actual modifications and additions can be found at the end of the catalogue!

Bei grau hinterlegten Artikeln muss die Verfügbarkeit angefragt werden.

Pour les produits marqués en gris, la disponibilité doit être demandée.

Items which are marked in grey, the stock availability needs to be inquired.



000.000

Wetterschenkel
Aluminium roh

Gewicht 0,266 kg/m
U = 0,100 m²/m
P = 0,034 m²/m

Länge 6 m

000.000

Renvoi d'eau
aluminium brut

poids 0,266 kg/m
U = 0,100 m²/m
P = 0,034 m²/m

Longueur 6 m

000.000

Weatherbar
aluminium mill finish

weight 0,266 kg/m
U = 0,100 m²/m
P = 0,034 m²/m

Length 6 m

Artikel, welche rot durchgestrichen sind, wurden aus dem Sortiment genommen.

Les articles barrés en rouge ont été retirés de la gamme.

Articles that have a red line through them have been removed from the product range.



000.000

Glasdichtung mit Abreisstege
EPDM, schwarz,
für Glasleistenseite

Einsatz siehe Seiten 34/35

VE = 100 m

000.000

Joint de vitrage avec partie déchirable
EPDM, noir,
pour côté parclose

Utilisation voir pages 34/35

UV = 100 m

000.000

Glazing weatherstrip with detachable strip
EPDM, black,
for glazing bead side

Application see pages 34/35

PU = 100 m

Bei Fragen wenden sie sich an ihren Fachberater bzw. einen Jansen Vertreter.

Pour toute question, adressez-vous à votre conseiller ou à un représentant Jansen.

If you have any questions, please contact your consultant or a Jansen representative.

JANSEN

Systemübersicht

Merkmale
Zulassungen

Sommaire du système

Caractéristiques
Homologations

Summary of system

Characteristics
Authorisations

2

Profilsortiment

Profile 50 und 60 mm
Deckprofile 50 und 60 mm
Zubehör
Verarbeitungshilfen
Zubehör VISS DV

Assortiment de profilé

Profilés 50 et 60 mm
Profilés de recouvrement 50 et 60 mm
Accessoires
Outils d'usinage
Accessoires VISS DV

Range of profiles

Profiles 50 and 60 mm
Cover sections 50 and 60 mm
Accessories
Assembly tools
Accessories VISS DV

6

Konstruktions-Hinweise

Schnittpunkte
Konstruktionsdetails
Anschlüsse am Bau
Verarbeitungshinweise
System-Hinweise

Indications du construction

Coupes de détails
Détails de construction
Raccords au mur
Indications d'usinage
Remarques concernant les systèmes

Construction instructions **35**

Section details
Construction details
Attachment to structure
Assembly instructions
System instructions

Alle Ausführungen dieser Dokumentation haben wir sorgfältig und nach bestem Wissen zusammengestellt. Wir können aber keine Verantwortung für die Benutzung der vermittelten Vorschläge und Daten übernehmen. Wir behalten uns technische Änderungen ohne Vorankündigung vor.
Aktuelle Version auf www.jansen.com

Nous avons apporté le plus grand soin à l'élaboration de cette documentation. Cependant, nous déclinons toute responsabilité pour l'utilisation faite de nos propositions et de nos données.
Nous nous réservons le droit de procéder à des modifications techniques sans préavis.
Version actuelle sur www.jansen.com

All the information contained in this documentation is given to the best of our knowledge and ability. However, we decline all responsibility for the use made of these suggestions and data.
We reserve the right to effect technical modifications without prior warning.
Current version available at www.jansen.com

Merkmale**Caractéristiques****Characteristics**

- | | | |
|--|--|--|
| <ul style="list-style-type: none">● CE-Kennzeichnung nach EN 13830● U_{CW}, eingebaut Werte bis 0.96 W/m²K● Ansichtsbreiten 50 und 60 mm● Füllelementstärken 15 bis 70 mm● Standardprofile ab Lager mit I_x Werten bis 2041 cm⁴● Füllelementgewichte bis 1800 kg● Zulassungen/Prüfungen EI30 | <ul style="list-style-type: none">● Marquage CE selon EN 13830● Valeurs U_{CW} (monté) jusqu'à 0.96 W/m²K● LMasse vue 50 et 60 mm● Éléments de remplissage de 15 à 70 mm d'épaisseur● Profilés standard disponibles sur stock avec valeurs I_x jusqu'à 2041 cm⁴● Poids de remplissage jusqu'à 1800 kg● Homologations/Essais EI30 | <p>VISS Fire EI30 Fassade/Trennwand
VISS Fire EI30 façade/cloison
VISS Fire EI30 façade/partition wall</p> <hr/> <ul style="list-style-type: none">● CE marking in accordance with EN 13830● U_{CW}, installed values to 0.96 W/m²K● 50 and 60 mm face widths● Infill panel thicknesses of 15 to 70 mm● Standard profiles from stock with I_x values to 2041 cm⁴● Infill unit weights up to 1800 kg● Authorisations/Tests EI30 |
|--|--|--|

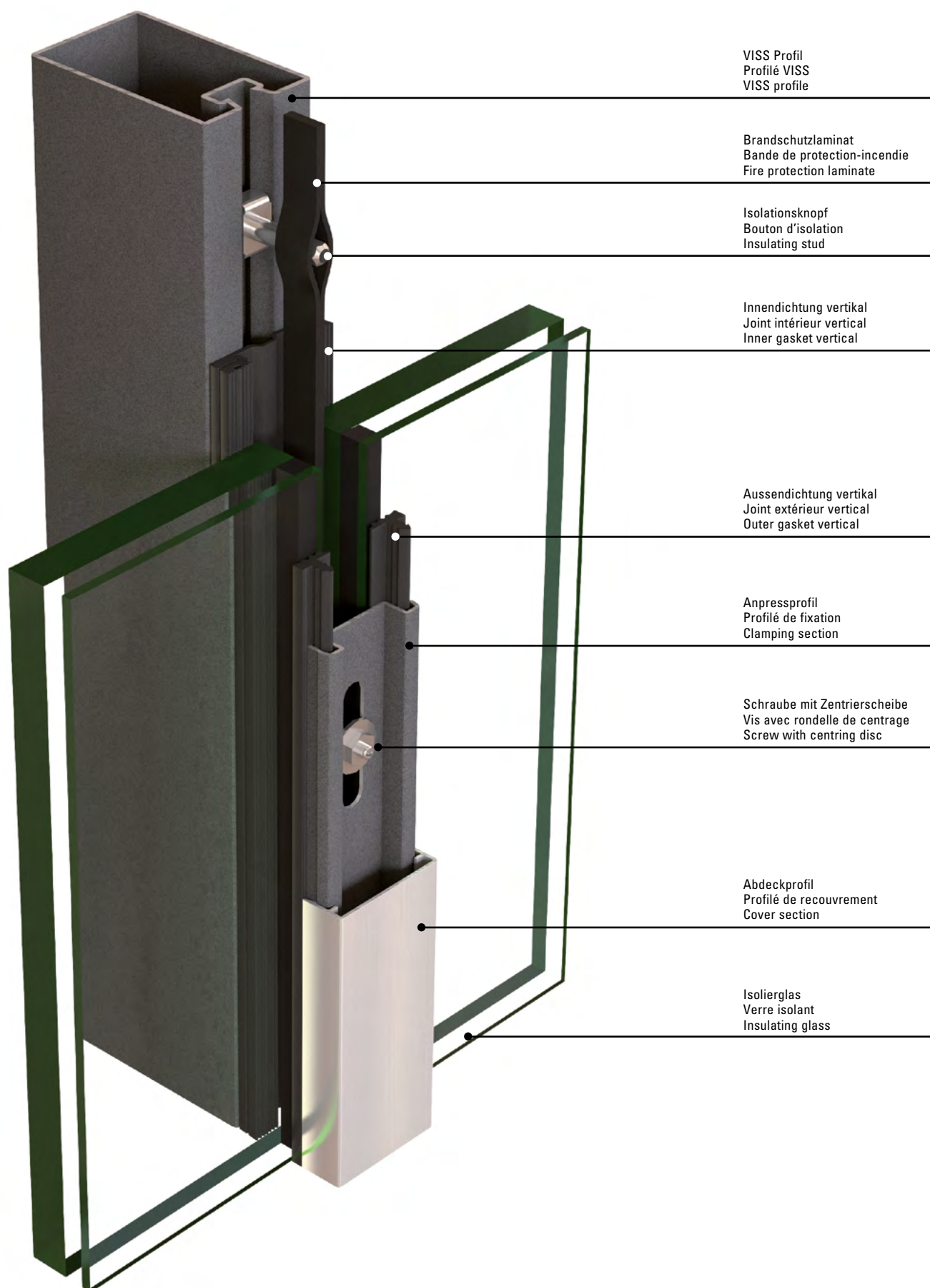

Zulassungen/Prüfungen
Homologations/Essais
Authorisations/Tests

VISS Fire EI30 Fassade/Trennwand
VISS Fire EI30 façade/cloison
VISS Fire EI30 façade/partition wall

VISS Fire
Brandschutzverglasung Klasse EI30

VISS Fire
Vitrage coupe feu Classe EI30

VISS Fire
Fire protection glazing Class EI30

CH: Zulassung beantragt

CH: Homologation en cours

CH: Authorisation applied

DE: Zulassung beantragt

DE: Homologation en cours

DE: Authorisation applied

TRAV

Technische Regeln für die
Verwendung von absturzsichernden
Verglasungen

TRAV

Règlement technique pour la
sécurité anti-chute des vitrages

TRAV

The technical regulations for
protecting glazing against
falling out

AbP P-2017/009

Kategorie A (900 mm)

AbP P-2017/009

Kategorie A (900 mm)

AbP P-2017/009

Kategorie A (900 mm)

Klemmverbindung

AbZ Z-14.4-465 (Brandschutzanker)

Jonction par serrage

AbZ Z-14.4-465 (boulon d'ancrage
anti-incendie)

Clamp connection

AbZ Z-14.4-465 (fire-proof anchor)

Pfosten-Riegel-Verbindung

AbZ Z-14.4-467 (T-Verbinder)

Jonction montant-traverse

AbZ Z-14.4-467 (Raccord en T)

Mullion-transom connection

AbZ Z-14.4-467 (Connecting spigot)

AT: Zulassung beantragt

AT: Homologation en cours

AT: Authorisation applied

FR: Zulassung beantragt

FR: Homologation en cours

FR: Authorisation applied

Die landesspezifischen
Brandschutz-Zulassungen bzw.
deren Bestimmungen und
Vorschriften sind zu beachten.
(Trennwand)
Das Gleiche gilt für die max.
Glasabmessungen, die variieren
können.

Les certificats de protection
incendie spécifiques au pays,
leurs dispositions et leurs
prescriptions doivent être respectés.
(Cloison)
Il en va de même pour les
dimensions maximales de verre qui
peuvent varier.

Fire-protection approvals or
applicable national regulations
and determinations must be
observed.
(Partition wall)
Same goes for the maximum glass
dimensions which may vary.

VISS Fire

**Produktnorm Vorhangfassade
 EN 13830**
 Luftdurchlässigkeit (EN 12152) AE
 Schlagregendichtheit (EN 12154) RE 1200
 Widerstandsfähigkeit bei Windlast
 (EN 13116)
 zulässige Last 2000 Pa
 erhöhte Last 3000 Pa
 Stossfestigkeit (EN 14019) I5/E5

 Prüfbericht 108 28793,
 Gutachten 155 28793 und
 Klassifizierungsbericht 100 28793,
 ift DE-Rosenheim

Luftschalldämmung
 nach EN ISO 140-3 (1993) und
 ISO/DIS 717-1 (1993), DIN 52210:

 $R_w = 42$ dB (bei Füllelementwert
 mind. $R_w = 42$ dB)

 Gutachtliche Stellungnahme vom
 13.9.1996 der EMPA, Dübendorf/CH

CWCT-Test
 Luftdurchlässigkeit: Druck 600 Pa PASS
 Wasserdichtheit statisch:
 Druck 600 Pa PASS
 Wasserdichtheit dynamisch PASS
 Windlast:
 Sicherheit 3600 Pa PASS
 Gebrauchstauglichkeit 2400 Pa PASS
 Schlauchtest PASS

 Certificate Number 04/32, January 2004
 Centre for Window and Cladding
 Technology, Wintech Engineering Ltd.,
 GB-Telford

VISS Fire

**Norme de produit façade rideau
 EN 13830**
 Perméabilité à l'air (EN 12152) AE
 Etanchéité à la pluie battante (EN 12154)
 RE 1200
 Résistance à la charge du vent (EN 13116)
 Charge admissible 2000 pa
 Charge élevée 3000 Pa
 Résistance aux chocs (EN 14019) I5/E5

 Rapport d'essai 108 28793,
 expertise 155 28793 et rapport de
 classification 100 28793,
 ift DE-Rosenheim

Isolement contre les sons aériens
 selon EN ISO 140-3 (1993) et
 ISO/DIS 717-1 (1993), DIN 52210:

 $R_w = 42$ dB (avec valeur du
 remplissage min. $R_w = 42$ dB)

 Expertise de l'EMPA Dübendorf/CH
 du 13.9.1996

CWCT-Test
 Perméabilité à l'air: Pression 600 Pa PASS
 Etanchéité à l'eau statique:
 Pression 600 Pa PASS
 Etanchéité à l'eau dynamique: PASS
 Résistance au vent:
 Sécurité 3600 Pa PASS
 Aptitude à l'usage 2400 Pa PASS
 Essai au tuyau PASS

 Certificate Number 04/32, January 2004
 Centre for Window and Cladding
 Technology, Wintech Engineering Ltd.,
 GB-Telford

VISS Fire

**Product approval curtain walls
 EN 13830**
 Air permeability (EN 12152) AE
 Resistance to driving rain (EN 12154)
 RE 1200
 Resistance to wind loads (EN 13116)
 Permissible load 2000 Pa
 Increased load 3000 Pa
 Impact streng (EN 14019) I5/E5

 Test report 108 28793,
 appraisal report 155 28793 and
 classification report 100 28793
 ift DE-Rosenheim

Insulation against airborne noise
 according to EN ISO 140-3 (1993)
 and ISO/DIS 717-1 (1993), DIN 52210:

 $R_w = 42$ dB (with glass/infill panel min.
 $R_w = 42$ dB)

 Expertise dated 13.9.1996 by
 EMPA Dübendorf/CH

CWCT-Test
 Air permeability: Pressure 600 Pa PASS
 Watertightness static:
 Pressure 600 Pa PASS
 Watertightness dynamic: PASS
 Wind resistance:
 Safety 3600 Pa PASS
 Serviceability 2400 Pa PASS
 Hose test PASS

 Certificate Number 04/32, January 2004
 Centre for Window and Cladding
 Technology, Wintech Engineering Ltd.,
 GB-Telford

Brandschutzglas
AGC

Verre coupe-feu
AGC

Fire resistant glass
AGC

Glastyp Type de verre Glass type	Stärke Épaisseur Thickness	Max. Glasabmessungen Hochformat Max. dimensions de verre Format Portrait Max. glass dimensions Portrait		Max. Glasabmessungen Querformat Max. dimensions de verre Format Paysage Max. glass dimensions Landscape		Max. Zwischenabmessungen Dimensions intermédiaires max. Max. intermediate dimensions	
		Kantenlänge Longueur d'arête Edge length (BxH)	Fläche Surface Area	Kantenlänge Longueur d'arête Edge length (BxH)	Fläche Surface Area	Kantenlänge Longueur d'arête Edge length (BxH)	Fläche Surface Area
Pyrobel 16*	≤ 70 mm	1650 x 3146 mm	4.72 m ²	2860 x 1375 mm	3.58 m ²	2860 x 3146 mm	4.15 m ²
Pyrobel 16EG*							
Pyrobel 16EG2*							
Pyrobel 16 IGU*							
Pyrobel 16 EG IGU*							
Pyrobel 16EG2 IGU*							

max. Anzahl der VSG-Folien*: 4x0.38 mm

max. Dichte Polycarbonat*: 1.52 mm

* Die Schichten können an jeder Position in der Gegenscheibe sein.

Alternative Formen:

Von den rechtwinkligen Glasabmessungen abweichende Formen sind zulässig, sofern die Form innerhalb der max. Fläche der oben erwähnten Abmessungen liegt und die weiteren Bedingungen gemäss Klassifizierungsbericht eingehalten werden.

Nombre max. de feuilles VSG*: 4x0.38 mm

Densité max. polycarbonate*: 1.52 mm

* Les couches peuvent se trouver à toutes les positions dans le verre.

Formes alternatives:

les formes différentes des dimensions rectangulaires sont admissibles si elles se trouvent dans la plage maximale des dimensions indiquées plus haut et si les autres conditions définies par le rapport de classement sont remplies.

Max. number of LSG foils*: 4x0.38 mm

Max. thickness of polycarbonate*: 1.52 mm

* The layers can be at any position in the glass.

Alternative shapes:

Shapes which deviate from the rectangular glass dimensions are permissible provided that the shape is within the maximum area of the abovementioned dimensions and the other conditions of the classification report are met.

Brandschutzglas
Pilkington

Verre coupe-feu
Pilkington

Fire resistant glass
Pilkington

Glastyp Type de verre Glass type	Stärke Épaisseur Thickness	Max. Glasabmessungen Hochformat Max. dimensions de verre Format Portrait Max. glass dimensions Portrait		Max. Glasabmessungen Querformat Max. dimensions de verre Format Paysage Max. glass dimensions Landscape		Max. Zwischenabmessungen Dimensions intermédiaires max. Max. intermediate dimensions	
		Kantenlänge Longueur d'arête Edge length (BxH)	Fläche Surface Area	Kantenlänge Longueur d'arête Edge length (BxH)	Fläche Surface Area	Kantenlänge Longueur d'arête Edge length (BxH)	Fläche Surface Area
Pyrostop 30-10, Pyrostop 30-12	≥ 15 mm	1400 x 2500 mm	3.50 m ²	2500 x 1400 mm	3.50 m ²	-	-
Pyrostop 30-22*	≥ 20 mm	1540 x 3000 mm	4.62 m ²	3000 x 1540 mm	4.62 m ²	1600 x 3000 mm 3000 x 1600 mm	4.62 m ²
Pyrostop 30-17*, Pyrostop 30-18*	≤ 70 mm	1540 x 3000 mm	4.62 m ²	3000 x 1540 mm	4.62 m ²	3000 x 3000 mm**	4.62 m ²
Pyrostop 30-20*							
Pyrostop 30-25*, Pyrostop 30-26*							
Pyrostop 30-27*, Pyrostop 30-28*							
Pyrostop 30-35*, Pyrostop 30-36*							
Pyrostop 30-37*, Pyrostop 30-38*							
Pyrostop 30-17 Triple*							
Pyrostop 30-18 Triple*							
Pyrostop 30-25 Triple* Pyrostop 30-26 Triple*							
Pyrostop 30-27 Triple* Pyrostop 30-28 Triple*							
Pyrostop 30-35 Triple* Pyrostop 30-36 Triple*							
Pyrostop 30-37 Triple* Pyrostop 30-38 Triple*							

max. Anzahl der VSG-Folien*: 4x0.38 mm

* Die Schichten können an jeder Position in der Gegenscheibe sein.

Alternative Formen: Von den rechtwinkligen Glasabmessungen abweichende Formen sind zulässig, sofern die Form innerhalb der max. Fläche der oben erwähnten Abmessungen liegt und die weiteren Bedingungen gemäss Klassifizierungsbericht eingehalten werden.

Nombre max. de feuilles VSG*: 4x0.38 mm

* Les couches peuvent se trouver à toutes les positions dans le verre.

Formes alternatives: les formes différentes des dimensions rectangulaires sont admissibles si elles se trouvent dans la plage maximale des dimensions indiquées plus haut et si les autres conditions définies par le rapport de classement sont remplies.

Max. number of LSG foils*: 4x0.38 mm

* The layers can be at any position in the glass.

Alternative shapes:

Shapes which deviate from the rectangular glass dimensions are permissible provided that the shape is within the maximum area of the abovementioned dimensions and the other conditions of the classification report are met.

** auf Anfrage / sur demande / on request

Zulassungen/Prüfungen
Homologations/Essais
Authorisations/Tests

VISS Fire EI30 Fassade/Trennwand
 VISS Fire EI30 façade/cloison
 VISS Fire EI30 façade/partition wall

Brandschutzglas
Vetrotech Saint-Gobain

Verre coupe-feu
Vetrotech Saint-Gobain

Fire resistant glass
Vetrotech Saint-Gobain

Glastyp Type de verre Glass type	Stärke Épaisseur Thickness	Max. Glasabmessungen Hochformat Max. dimensions de verre Format Portrait Max. glass dimensions Portrait		Max. Glasabmessungen Querformat Max. dimensions de verre Format Paysage Max. glass dimensions Landscape		Max. Zwischenabmessungen Dimensions intermédiaires max. Max. intermediate dimensions	
		Kantenlänge Longueur d'arête Edge length (BxH)	Fläche Surface Area	Kantenlänge Longueur d'arête Edge length (BxH)	Fläche Surface Area	Kantenlänge Longueur d'arête Edge length (BxH)	Fläche Surface Area
EN 14449 Brandschutz-Sicherheitsglas Verre de sécurité résistant au feu Fire resistant safety glass CONTRAFLAM 30 CONTRAFLAM 30-2	≥ 16 mm ≥ 30 mm	1500 x 3356 mm 2700 x 4600 mm	5.03 m ² 12.42 m ²	3270 x 1500 mm -	4.91 m ² -	3270 x 3356 mm -	4.97 m ² -
EN 1279 2-fach/3-fach Brandschutz-Isolierglas Double/triple vitrage isolant résistant au feu Double/triple insulating glass unit CONTRAFLAM 30 IGU*: CONTRAFLAM 30 CLIMALIT (2-fach / double / double) CONTRAFLAM 30 CLIMAPLUS (2-fach / double / double) CONTRAFLAM 30 CLIMATOP (3-fach / triple / triple)	≤ 70 mm	1500 x 3356 mm	5.03 m ²	3270 x 1500 mm	4.91 m ²	3270 x 3356 mm	4.97 m ²
<p>max. Anzahl der VSG-Folien*: 8x0.38 mm Alternative Formen: Von den rechteckigen Glasabmessungen abweichende Formen sind zulässig, sofern die Form innerhalb der max. Fläche der oben erwähnten Abmessungen liegt und die weiteren Bedingungen gemäss Klassifizierungsbericht eingehalten werden.</p> <p>Nombre max. de feuilles VSG*: 8x0.38 mm Formes alternatives: les formes différentes des dimensions rectangulaires sont admissibles si elles se trouvent dans la plage maximale des dimensions indiquées plus haut et si les autres conditions définies par le rapport de classement sont remplies.</p> <p>Max. number of LSG foils*: 8x0.38 mm Alternative shapes: Shapes which deviate from the rectangular glass dimensions are permissible provided that the shape is within the maximum area of the abovementioned dimensions and the other conditions of the classification report are met.</p>							

*** Multifunktionen/multifonctions/multifunctions**

PLANITHERM Wärmeschutz / isolation thermique / thermal insulation
 COOL-LITE Sonnenschutz / contrôle solaire / solar control
 STADIP SILENCE Schallschutz / affaiblissement acoustique / sound reduction
 SECURIT ALARM Alarm Glas / verre connecté à l'alarme / alarm glass
 EMS STADIP reduziert elektromagnetische Strahlung / réduire le rayonnement électromagnétique / reduce of electromagnetic radiation

SUPERCONTRYX	Röntgenschutz / protection contre les rayons X / X-ray protection
THERMOVIT	Heizglas / verre chauffant / heated glass
STADIP COLOR	farbige Folien / films de couleur / colored foils
BIOCLEAN	selbstreinigend / autonettoyant / self-cleaning
PRIVA-LITE	schaltbar transparent-opak / occultation commandée / switchable transparent-opaque
SCREEN	integrierte Jalousien / stores intégrés / integrated blinds
DIAMANT	extra weißes Glas / verre extra-clair / extra clear glass
MIRASTAR	Spionspiegel / verre chromé / spy glass
EMALIT	emalliertes Glas / verre émaillé / enameled glass
SERALIT	siebbedrucktes Glas / verre sérigraphié / screen printed glass
PICTUREIT	Digitaldruck / impression digitale / digital printing
PARSOL	eingefärbtes Glas / verre teinté dans la masse / body tinted glass
SATINOVO	mattiertes Glas / verre maté / matt glass
DECOR	Ornamentglas / verre imprimé / patterned glass
PROTECT	Sicherheitsglas / verre de sécurité résistant l'attaque manuelle / safety glass (EN 356 P1A-P5A)
VETROGARD	Sicherheitsglas / verre de sécurité résistant l'attaque manuelle / safety glass (EN 356 P6B)

Brandschutzglas
Schüco

Verre coupe-feu
Schüco

Fire resistant glass
Schüco

Glastyp Type de verre Glass type	Stärke Épaisseur Thickness	Max. Glasabmessungen Hochformat Max. dimensions de verre Format Portrait Max. glass dimensions Portrait		Max. Glasabmessungen Querformat Max. dimensions de verre Format Paysage Max. glass dimensions Landscape		Max. Zwischenabmessungen Dimensions intermédiaires max. Max. intermediate dimensions	
		Kantenlänge Longueur d'arête Edge length (BxH)	Fläche Surface Area	Kantenlänge Longueur d'arête Edge length (BxH)	Fläche Surface Area	Kantenlänge Longueur d'arête Edge length (BxH)	Fläche Surface Area
SchücoFlam 30 C*	≤ 70 mm	1500 x 3356 mm	5.03 m ²	3270 x 1500 mm	4.91 m ²	3270 x 3356 mm	4.97 m ²
SchücoFlam 30 ISO-C*							
SchücoFlam 30 ISO-3 C*							

max. Anzahl der VSG-Folien*: 8x0.38 mm

* Die Schichten können an jeder Position in der Gegenscheibe sein.

Alternative Formen: Von den rechtwinkligen Glasabmessungen abweichende Formen sind zulässig, sofern die Form innerhalb der max. Fläche der oben erwähnten Abmessungen liegt und die weiteren Bedingungen gemäss Klassifizierungsbericht eingehalten werden.

Nombre max. de feuilles VSG*: 8x0.38 mm

* Les couches peuvent se trouver à toutes les positions dans le verre.

Formes alternatives:

les formes différentes des dimensions rectangulaires sont admissibles si elles se trouvent dans la plage maximale des dimensions indiquées plus haut et si les autres conditions définies par le rapport de classement sont remplies.

Max. number of LSG foils*: 8x0.38 mm

* The layers can be at any position in the glass.

Alternative shapes:

Shapes which deviate from the rectangular glass dimensions are permissible provided that the shape is within the maximum area of the abovementioned dimensions and the other conditions of the classification report are met.

Übersicht Systemkomponenten

Aperçu des composants du système

Overview system components

Pfosten
Montant
Mullion

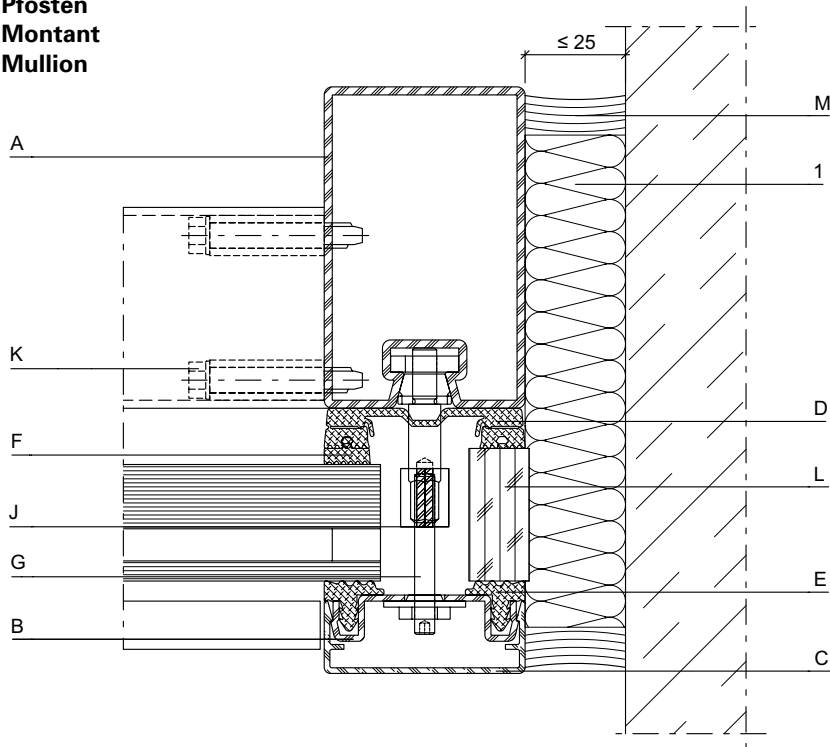

Pos. Artikel

- A VISS Profil
- B Anpressprofil
- C Deckprofil
- D Innendichtung
- E Aussendichtung
- F Ausgleichsdichtung
- G Brandschutzanker
- H Glasauflage
- I Tragklotz
- J Brandschutzlaminat
- K T-Verbinder
- L Ausgleichsprofil
- M Silikon

Pos. Article

- A Profilé VISS
- B Profilé de fixation
- C Profilé de recouvrement
- D Joint intérieur
- E Joint extérieur
- F Joint de compensation
- G Boulon d'ancrage anti-incendie
- H Support de vitrage
- I Cale de remplissage
- J Bande de protection-incendie
- K Raccord en T
- L Profilé de compensation
- M Silicone

Riegel
Traverse
Transom

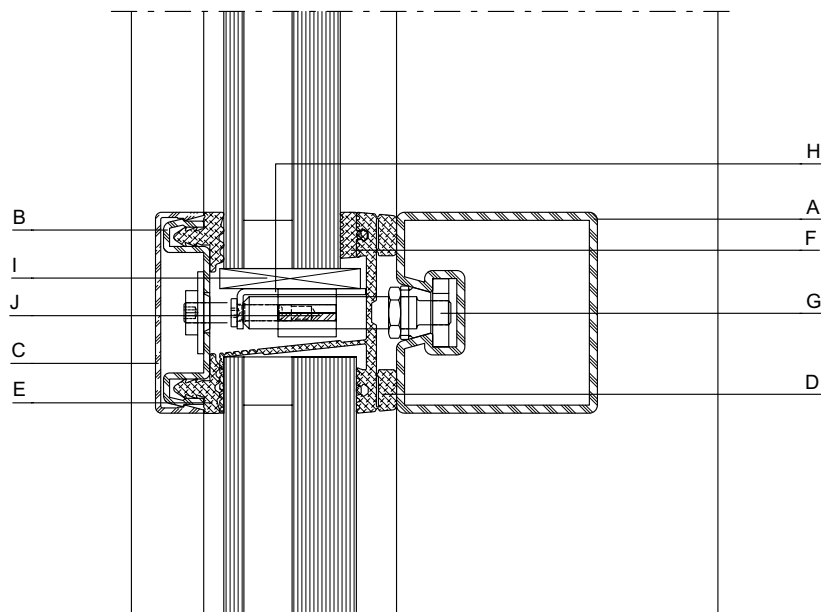

Pos. Item

- A VISS profile
- B Clamping section
- C Cover section
- D Inner gasket
- E Outer gasket
- F Compensating gasket
- G Fire-protect anchor
- H Glazing support
- I Support
- J Fire protection laminate
- K Connecting spigot
- L Spacer profile
- M Silicon

Typenübersicht
Sommaire des types
Summary of types

VISS Fire EI30 Fassade/Trennwand
VISS Fire EI30 façade/cloison
VISS Fire EI30 façade/partition wall

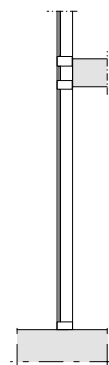
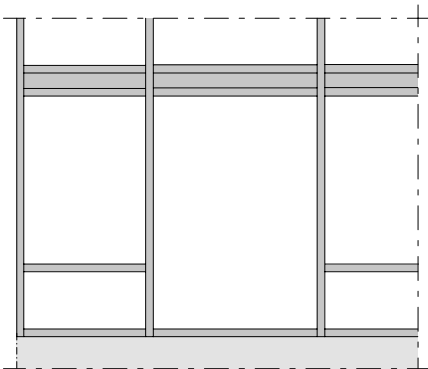
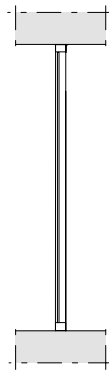
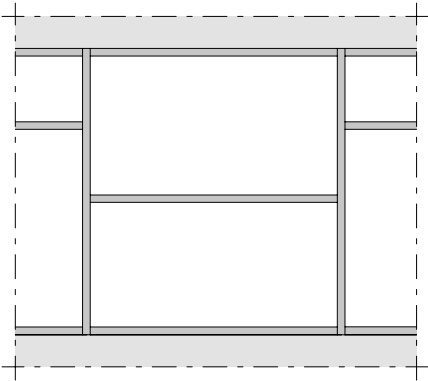
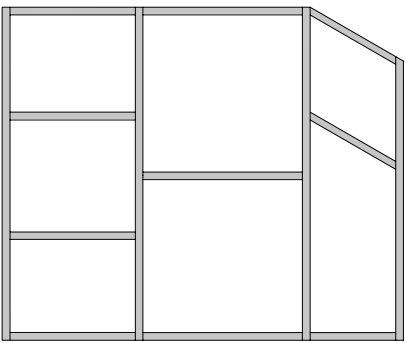
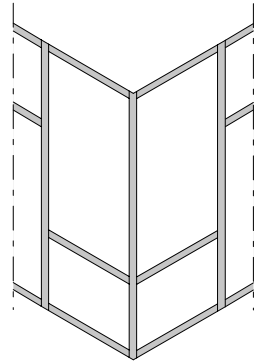
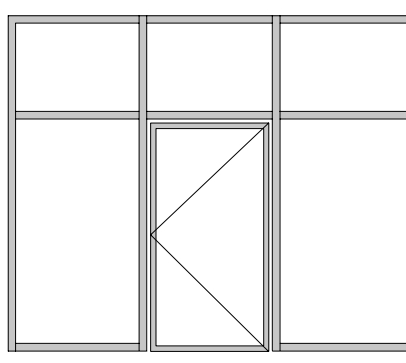
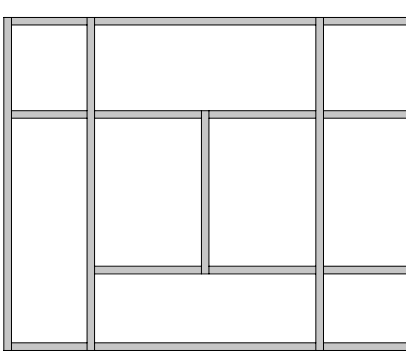

JANIssoft

JANIssoft ermöglicht die Planung, Kalkulation und Konstruktion von Jansen Systemen für Fenster, Türen und Fassaden in 2D sowie 3D. Mit der neuen Version können Planer und Verarbeiter Angebote und Bestellungen mit den entsprechenden Detailzeichnungen und Berechnungen einfach erstellen. Dank der optimierten Softwarefunktionen lässt sich der Prozess von der Arbeitsvorbereitung über die Fertigung noch effizienter gestalten.

JANIssoft

JANIssoft permet l'étude, le calcul et la construction de systèmes Jansen en 2D et 3D pour les fenêtres, les portes et les façades. La nouvelle version permet aux projeteurs et aux transformateurs d'établir facilement des offres et des commandes avec les plans de détail et les calculs. Des préparatifs du travail à la commande de la machine, le processus peut être coordonné de manière encore plus efficace grâce aux fonctions optimisées du logiciel.

JANIssoft

JANIssoft allows Jansen systems for windows, doors and façades to be planned, calculated and designed in 2D and 3D. Using the new version, developers and fabricators can easily create quotations and orders with the corresponding detailed drawings and calculations. Thanks to optimised software functionality, the procedure from process planning to fabrication can be made even more efficient.

Jansen Docu Center

Die Plattform zum effizienten Arbeiten mit Jansen Dokumentationen. Im Jansen Docu Center stehen alle Produktinformationen jederzeit digital in der aktuellsten Version zur Verfügung: von Architekten-Informationen über Bestell- und Fertigungskatalogen bis hin zu Anleitungen und Prospekten sowie Videos. Die Inhalte können einfach und schnell aufgerufen werden. Ein für den Anwender komfortables papierloses Arbeiten, das zahlreiche Vorteile bietet.

Jansen Docu Center

La plate-forme pour travailler efficacement avec les documentations Jansen. Le Jansen Docu Center met à votre disposition les informations sur les produits, en format numérique et dans une version actualisée: des catalogues de commande et de fabrication aux instructions et prospectus, en passant par les informations destinées aux architectes et vidéos. Les contenus sont facilement et rapidement accessibles. Une manière de travailler confortable et offrant de nombreux avantages.

Jansen Docu Center

The platform for working efficiently with Jansen documentation. The latest version of all the product information is available digitally at any time in the Jansen Docu Center – from order and fabrication manuals to architect information, instructions and brochures and videos. The content can be retrieved quickly and easily. The user can work conveniently without paper, which has numerous benefits.

Download CAD Daten

DXF

DWG

Sie können die Zeichnungen in den Formaten DXF und/oder DWG herunterladen. Klicken Sie auf das entsprechende Icon und der Download erfolgt.

Die Hinweise «Artikelbibliothek/Türbeschläge/Fensterbeschläge» bedeuten, dass Sie mit einem Klick die gesamte Artikelbibliothek des entsprechenden Systems herunterladen (Profile, Beschläge, Glasleisten, Zubehör etc.).

Télécharger fichiers DAO

DXF

DWG

Vous pouvez télécharger les dessins aux formats DXF et/ou DWG. Cliquez sur l'icône correspondante et le téléchargement s'effectuera.

Les indications «Bibliothèque des articles/Ferures de porte/Ferrures de fenêtres» signifie que vous téléchargez la totalité de la bibliothèque des articles du système donné (profilés, ferrures, parcloles, accessoires etc.).

Download CAD files

DXF

DWG

You can download the drawings in DXF and/or DWG format. Click on the relevant icon to begin the download.

The items «Article library/Door fittings/Window fittings» means that you download the entire article library for the corresponding system with one click (profiles, fittings, glazing beads, accessories etc.).

Profile 50 mm (Massstab 1:3)

Profils 50 mm (échelle 1:3)

Profiles 50 mm (scale 1:3)

VISS Fire EI30 Fassade/Trennwand

VISS Fire EI30 façade/cloison

VISS Fire EI30 façade/partition wall

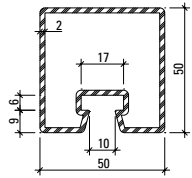

76.694
76.694 Z

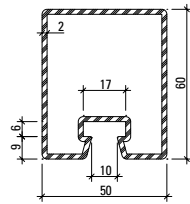

76.671
76.671 Z

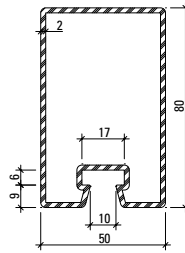

76.696
76.696 Z

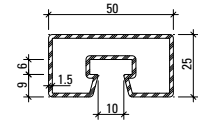

76.682 1,2

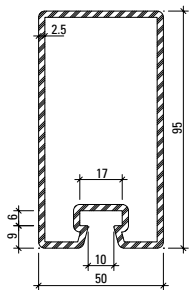

76.697
76.697 Z

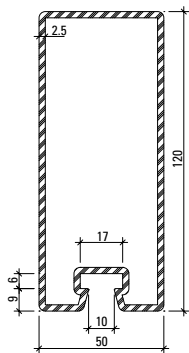

76.679
76.679 Z

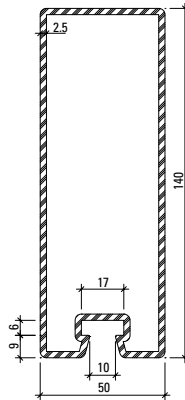

76.666
76.666 Z

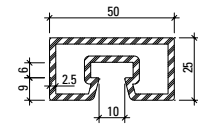

76.680 1,2

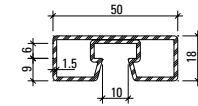

76.692 1,2

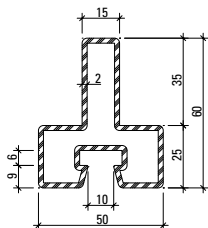

76.114

1 Nur zusammengesetzte Profile
Uniquement profilés assemblés
Only assembled profiles

2 Nur für Anschlüsse an Janisol
Uniquement pour raccords à Janisol
Only for attachments to Janisol

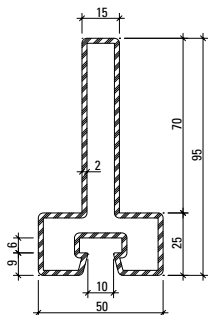

76.115

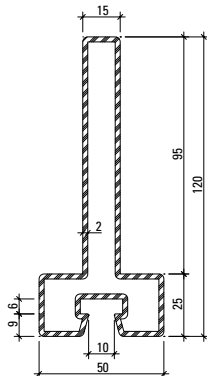

76.116

Profil-Nr.	G kg/m	F cm ²	I _x cm ⁴	W _x cm ³	I _y cm ⁴	W _y cm ³	U m ² /m	L mm
76.666	7,910	10,1	241,3	32,3	43,7	17,5	0,412	6500
76.671	3,860	4,9	23,3	7,2	17,3	6,9	0,260	6500
76.679	7,120	9,1	162,2	25,2	37,9	15,2	0,373	6500
76.680	3,390	4,3	3,2	2,4	11,1	4,4	0,182	6100
76.682	2,120	2,7	2,2	1,7	7,2	2,9	0,190	6000
76.692	1,900	2,5	0,9	1,0	5,9	2,4	0,176	6000
76.694	3,500	4,5	14,7	5,6	15,0	6,0	0,240	6500
76.696	4,450	5,7	47,6	11,1	21,9	8,8	0,300	6500
76.697	6,100	7,9	90,2	17,6	31,0	12,4	0,330	6500
76.114	3,820	4,9	15,4	4,1	9,8	3,9	0,251	6000
76.115	4,920	6,3	54,8	9,3	10,4	4,2	0,321	6000
76.116	5,710	7,3	105,0	14,3	10,8	4,3	0,371	6000

Profile 60 mm (Massstab 1:3)

Profils 60 mm (échelle 1:3)

Profiles 60 mm (scale 1:3)

VISS Fire EI30 Fassade/Trennwand

VISS Fire EI30 façade/cloison

VISS Fire EI30 façade/partition wall

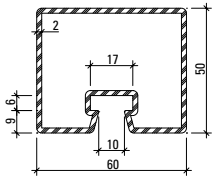

76.695
76.695 Z

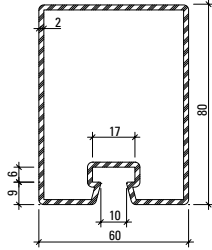

76.678
76.678 Z

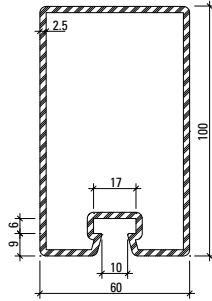

76.684
76.684 Z

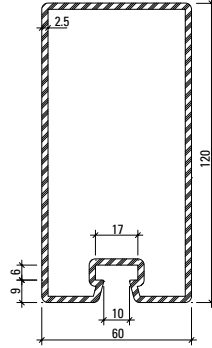

76.698
76.698 Z

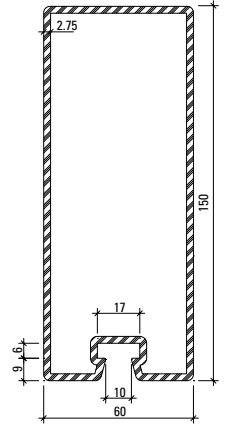

76.667
76.667 Z

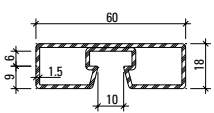

76.693 ^{1,2}

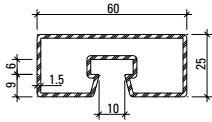

76.683 ^{1,2}

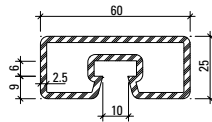

76.681 ¹

1 Nur zusammengesetzte Profile
Uniquement profilés assemblés
Only assembled profiles

2 Nur für Anschlüsse an Janisol
Uniquement pour raccordements à Janisol
Only for attachments to Janisol

Artikelbibliothek
Bibliothèque des articles
Article library

DXF

DWG

Stabachse
Axe de la barre
Bar axis

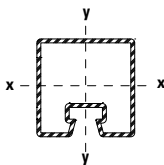

Profil-Nr.	G kg/m	F cm ²	I _x cm ⁴	W _x cm ³	I _y cm ⁴	W _y cm ³	U m ² /m	L mm
76.667	9,530	12,1	342,8	43,0	75,1	25,0	0,452	6500
76.678	4,800	6,1	53,9	12,6	32,8	11,0	0,320	6500
76.681	3,790	4,8	3,8	2,9	17,3	5,8	0,202	6100
76.683	2,360	3,0	2,6	2,0	11,1	3,7	0,210	6000
76.684	6,730	8,6	114,1	21,3	48,3	16,1	0,352	6500
76.693	2,140	2,8	1,3	1,3	9,3	3,1	0,196	6000
76.695	3,800	4,9	17,2	6,5	22,9	7,6	0,260	6500
76.698	7,500	9,7	179,6	28,0	56,6	18,9	0,400	6500

Profile 60 mm (Massstab 1:3)
Profils 60 mm (échelle 1:3)
Profiles 60 mm (scale 1:3)

VISS Fire EI30 Fassade/Trennwand
 VISS Fire EI30 façade/cloison
 VISS Fire EI30 façade/partition wall

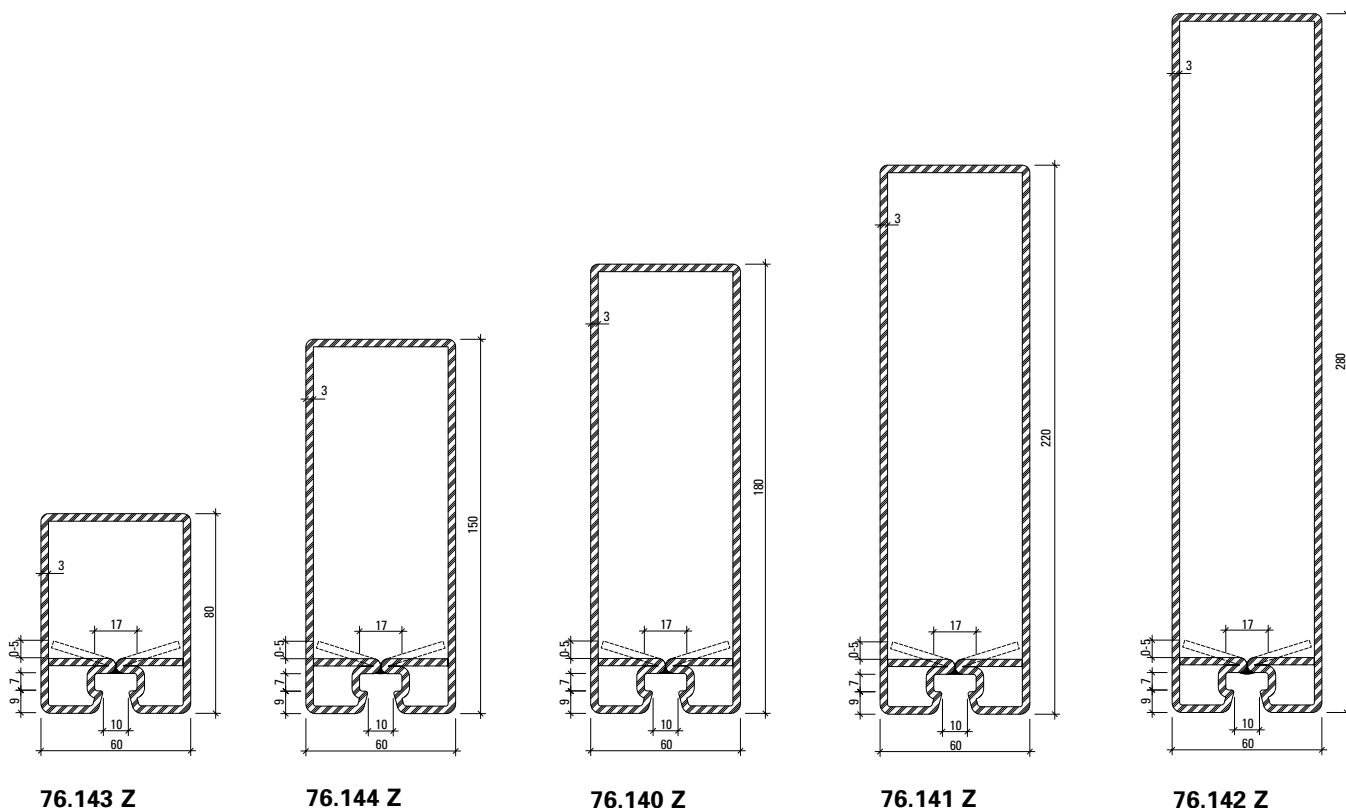

Aufgrund von Fertigungstoleranzen kann die Lage des Rückbogens von 0 bis 5 mm variieren.

En raison des tolérances de fabrication, la position du segment coudé peut varier de 0 à 5 mm.

Due to fabrication tolerances, the position of the rear arch may vary between 0 and 5 mm.

Oberfläche/Werkstoff

Artikel-Nr.

ohne Zusatz = blank

mit Z = bandverzinkter Stahl

Surface/Matériau

No. d'article

sans supplément = brut

avec Z = bandes d'acier zinguées

Surface/Material

Part no.

without addition = bright

with Z = galvanised strip

Artikelbibliothek
 Bibliothèque des articles
 Article library

DXF **DWG**

Profil-Nr.	G kg/m	F cm ²	I _x cm ⁴	W _x cm ³	I _y cm ⁴	W _y cm ³	U m ² /m	L mm
76.140 Z	12,946	16,47	649,2	64,3	100,0	33,2	0,516	8000
76.141 Z	14,833	18,87	1090,2	89,1	119,1	39,7	0,596	8000
76.142 Z	17,662	22,5	2041,7	132,7	148,4	49,5	0,716	10000
76.143 Z	8,340	10,62	80,4	17,9	50,8	16,9	0,316	6500
76.144 Z	11,630	14,82	406,0	47,9	85,0	28,3	0,456	6500

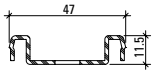
Deckprofile 50 mm (Masstab 1:3)**Profils de recouvrement 50 mm (échelle 1:3)****Cover sections 50 mm (scale 1:3)****VISS Fire EI30 Fassade/Trennwand****VISS Fire EI30 façade/cloison****VISS Fire EI30 façade/partition wall**

400.800 Z
400.800 (AISI 304)

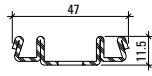

400.801 Z

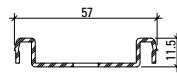

400.802 Z
400.802 (AISI 304)

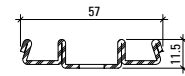

400.803 Z

Profil-Nr.	G kg/m	L mm
400.800	0,940	6000
400.800 Z	0,935	6000
400.801 Z	1,210	6000

Profil-Nr.	G kg/m	L mm
400.802	1,065	6000
400.802 Z	1,060	6000
400.803 Z	1,319	6000

**Edelstahl Deckprofile
Pfosten****Profils de recouvrement acier Inox
Montant****Stainless steel cover sections
Mullion**

Werkstoff 1.4301 (AISI 304)
geschliffen, Korn 220/240,
mit Schutzfolie

Qualité 1.4301 (AISI 304)
brossé, grain 220/240,
avec feuille de protection

Material 1.4301 (AISI 304)
polished, grain 220/240,
with protective film

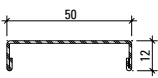

400.860

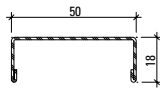

400.861



Werkstoff 1.4401 (AISI 316)
geschliffen, Korn 220/240,
mit Schutzfolie

Qualité 1.4401 (AISI 316)
brossé, grain 220/240,
avec feuille de protection

Material 1.4401 (AISI 316)
polished, grain 220/240,
with protective film

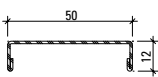

400.862

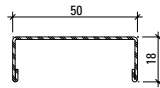

400.863



Profil-Nr.	G kg/m	L mm
400.860	0,644	6000
400.861	0,734	6000

Profil-Nr.	G kg/m	L mm
400.862	0,652	6000
400.863	0,744	6000

Deckprofile 50 mm (Masstab 1:3)**Profils de recouvrement 50 mm (échelle 1:3)****Cover sections 50 mm (scale 1:3)**

VISS Fire EI30 Fassade/Trennwand

VISS Fire EI30 façade/cloison

VISS Fire EI30 façade/partition wall

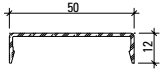
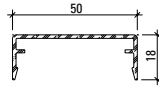
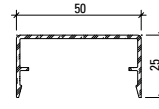
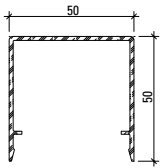
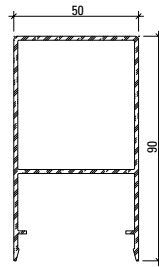
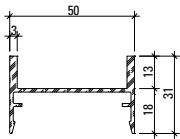
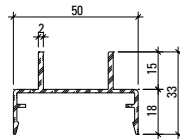
**407.860****407.861****407.862****407.863****407.864****407.900****407.911**

Profil-Nr.	G kg/m	U m ² /m	P m ² /m	L mm
407.860	0,266	0,147	0,072	6000
407.861	0,341	0,185	0,084	6000
407.862	0,394	0,213	0,098	6000

Profil-Nr.	G kg/m	U m ² /m	P m ² /m	L mm
407.863	0,660	0,313	0,148	6000
407.864	1,344	0,360	0,228	6000
407.900	0,556	0,240	0,138	6000
407.911	0,510	0,245	0,146	6000

Werkstoff

Aluminium EN AW 6060 T66 roh, leicht eingeölt

Matériau

Aluminium EN AW 6060 T66 brut, légèrement huilé

Material

Aluminium EN AW 6060 T66 mill finish, slightly oiled

Deckprofile 60 mm (Masstab 1:3)
Profils de recouvrement 60 mm (échelle 1:3)
Cover sections 60 mm (scale 1:3)

VISS Fire EI30 Fassade/Trennwand
 VISS Fire EI30 façade/cloison
 VISS Fire EI30 façade/partition wall

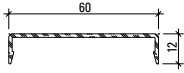

407.865

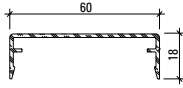

407.866

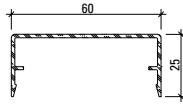

407.867

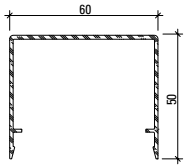

407.868

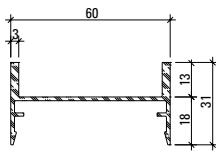

407.901

Profil-Nr.	G kg/m	U m ² /m	P m ² /m	L mm
407.802	0,558	0,190		6000
407.865	0,304	0,167	0,082	6000
407.866	0,379	0,205	0,094	6000
407.867	0,432	0,223	0,108	6000

Profil-Nr.	G kg/m	U m ² /m	P m ² /m	L mm
407.868	0,750	0,330	0,160	6000
407.901	0,590	0,255	0,148	6000

Werkstoff

Aluminium EN AW 6060 T66 roh, leicht eingeölt

Matériau

Aluminium EN AW 6060 T66 brut, légèrement huilé

Material

Aluminium EN AW 6060 T66 mill finish, slightly oiled

Artikelbibliothek
 Bibliothèque des articles
 Article library

DXF

DWG

Biegeradien
Travaux de cintrage
Bending data

VISS Fire EI30 Fassade/Trennwand
 VISS Fire EI30 façade/cloison
 VISS Fire EI30 façade/partition wall

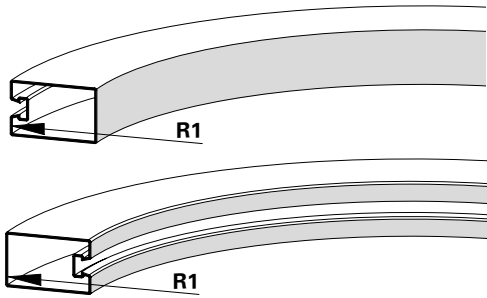

Profil Profilé Profile	R1 mm	R2 mm
76.114	1600	750
76.115	2100	1050
76.666	2650	850
76.667	2350	1000
76.671	900	750
76.678	1600	1100
76.679	2550	850
76.684	1600	900
76.694	550	550
76.695	650	700
76.696	1100	650
76.697	1300	850
76.698	2150	1100

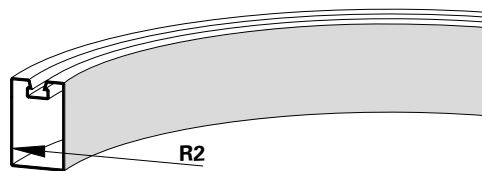

Profil Profilé Profile	R1 mm	R2 mm
76.680	400	450
76.681	400	550
76.683	700	750
76.692	600	650
76.693	600	900

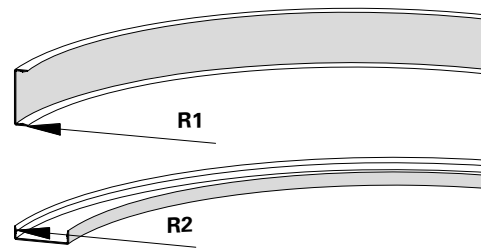

Profil Profilé Profile	R1 mm	R2 mm
407.815	500	700
407.860	500	850
407.861	500	950
407.862	700	1250
407.865	500	1250
407.866	700	1300
407.867	700	1300

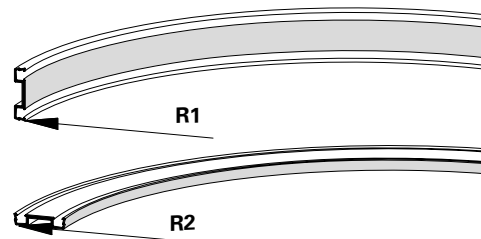

Profil Profilé Profile	R1 mm	R2 mm
400.800	800	1500
400.800 Z	800	1200
400.801 Z	800	1800
400.802	800	1500
400.802 Z	800	1500
400.803	800	1800
407.800	500	1050
407.802	500	1100

Hinweis:
 Alle Profile sind auch in verzinkter Ausführung (Z) biegebar.

Beim Biegen von engen Radien kann sich die VISS-Nute verjüngen.

Remarque:
 Tous les profilés sont également cintrables en exécution galvanisée (Z).

La rainure VISS peut s'amincir lors du cintrage pour des rayons serrés.

Note:
 All profiles can also be bent into curves in the galvanised finish (Z).

The VISS flute might be tapered down when bending narrow radii.

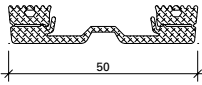

455.537

Innendichtung vertikal
50 mm breit, EPDM schwarz

VE = 50 m

455.537

Joint intérieur vertical
largeur 50 mm, EPDM noir

UV = 50 m

455.537

Inner gasket, vertical
50 mm wide, EPDM black

PU = 50 m

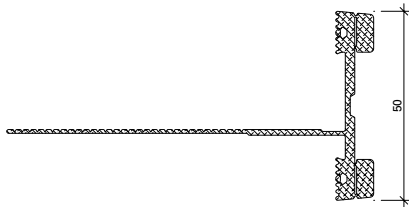

455.558

Innendichtung horizontal
50 mm breit, EPDM schwarz

VE = 50 m

455.558

Joint intérieur horizontal
largeur 50 mm, EPDM noir

UV = 50 m

455.558

Inner gasket, horizontal
50 mm wide, EPDM black

PU = 50 m

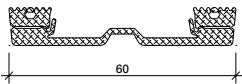

455.538

Innendichtung vertikal
60 mm breit, EPDM schwarz

VE = 50 m

455.538

Joint intérieur vertical
largeur 60 mm, EPDM noir

UV = 50 m

455.538

Inner gasket, vertical
60 mm wide, EPDM black

PU = 50 m

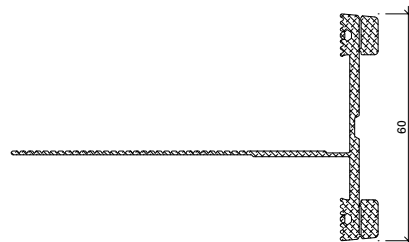

455.559

Innendichtung horizontal
60 mm breit, EPDM schwarz

VE = 50 m

455.559

Joint intérieur horizontal
largeur 60 mm, EPDM noir

UV = 50 m

455.559

Inner gasket, horizontal
60 mm wide, EPDM black

PU = 50 m

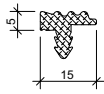

455.588

Aussendichtung
für Anpressprofile,
EPDM schwarz

VE = 100 m

Einsatz:
Pfosten, Riegel oben

455.588

Joint extérieur
pour profilés de fixation,
EPDM noir

UV = 100 m

Utilisation:
Montant, traverse supérieur

455.588

Outer gasket
for clamping sections,
EPDM black

PU = 100 m

Application:
Mullion, transoms top

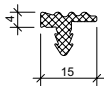

455.589

Aussendichtung
für Anpressprofile,
EPDM schwarz

VE = 50 m

Einsatz:
Riegel unten

455.589

Joint extérieur
pour profilés de fixation,
EPDM noir

UV = 50 m

Utilisation:
Traverse inférieur

455.589

Outer gasket
for clamping sections,
EPDM black

PU = 50 m

Application:
Transom bottom



455.565

Ausgleichsdichtung 2 mm
EPDM schwarz,
für Innendichtungen 455.537/
455.538/455.558/455.559

VE = 50 m

455.565

Joint de compensation 2 mm
EPDM noir, pour joint
intérieur 455.537/
455.538/455.558/455.559

UV = 50 m

455.565

Compensating gasket 2 mm
EPDM black,
for inner gasket 455.537/
455.538/455.558/455.559

PU = 50 m



455.566

Ausgleichsdichtung 4 mm
EPDM schwarz,
für Innendichtungen 455.537/
455.538/455.558/455.559

VE = 50 m

455.566

Joint de compensation 4 mm
EPDM noir, pour joint
intérieur 455.537/
455.538/455.558/455.559

UV = 50 m

455.566

Compensating gasket 4 mm
EPDM black,
for inner gasket 455.537/
455.538/455.558/455.559

PU = 50 m

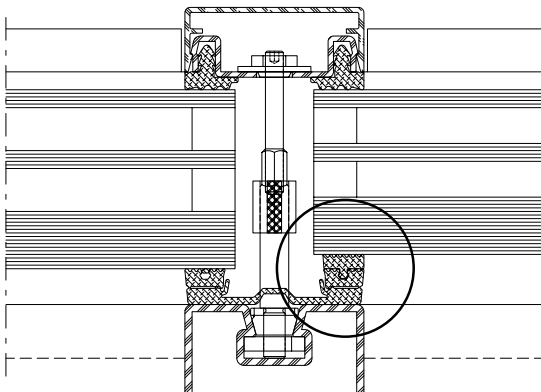



451.086 14,5x2 mm
451.087 7,2x2 mm

Brandschutzlaminat
selbstklebend

VE = 1 Rolle à 25 m

451.086 14,5x2 mm
451.087 7,2x2 mm

Bande de protection-incendie
auto-adhésive, 14,4 x 1,8 mm

UV = 1 rouleau à 25 m

451.086 14,5x2 mm
451.087 7,2x2 mm

Fire protection laminate
auto-adhésive, 14,4 x 1,8 mm

PU = 1 roll, 25 m each



452.085 50 x 0,8 mm

Aluminium-Dichtband
flexibel, dampfdicht,
selbstklebend

VE = 1 Rolle à 50 m

452.085 50 x 0,8 mm

Bande butyl en aluminium
autocollante, flexible,
étanche à la vapeur

UV = 1 rouleau à 50 m

452.085 50 x 0,8 mm

Aluminium butyl sealing strip
flexible, damp-proof,
self adhesive

PU = 1 roller 50 m each



452.084

Klebmasse
schwarz, Hybrid Polymer, Kleber
für Paneele, inkl. Ausspritzdüsen

VE = 1 Kartusche 290 ml

452.084

Pâte à coller
noir, polymère hybride, colle
pour panneaux, avec gicleurs
d'injection

UV = 1 cartouche de 290 ml

452.084

Bonding compound
black, hybrid polymer,
adhesive for panels,
includes spray nozzles

PU = 1 cartridge 290 ml



452.086

Dichtmasse
transparent, Silikon für
Glasversiegelungen und
Maueranschlüsse,
inkl. Ausspritzdüsen

VE = 20 Kartuschen à 310 ml

452.086

Pâte à étancher
transparent, silicone pour
étanchéité du verre et raccorde-
ment au mur, avec gicleurs
d'injection

UV = 20 cartouches à 310 ml

452.086

Sealing compound
transparent, silicone for sealing
glass and wall connection,
includes spray nozzles

PU = 20 cartridges 310 ml each



450.091

Reiniger
zur Reinigung aller Teile vor
dem Anbringen der Dichtmasse
450.092

VE = 1 Liter

450.091

Nettoyant
pour nettoyer toutes les pièces
avant d'appliquer la pâte à
étancher 450.092

UV = 1 litre

450.091

Cleaner
for cleaning all components
before applying the sealing
compound 450.092

PU = 1 litre



450.092

Kleb- und Dichtmasse
schwarz, für das Abdichten
der Dichtungs-Stösse und
-Durchbrüche

VE = 1 Kartusche 290 ml

450.092

Pâte à coller et à étancher
noire, pour étancher les
raccordements et les points de
raccords des joints intérieurs

UV = 1 cartouche 290 ml

450.092

Sealing and bonding compound
black, for sealing the joints and
holes in the weatherstrip

PU = 1 cartridge 290 ml

Wichtig:
Ohne Vorbehandlung mit
Reiniger 450.091 ist die Klebe-
haftung nicht gewährleistet.

Important:
Sans traitement préliminaire
avec un nettoyant 450.091,
l'adhésion n'est pas garantie.

Important:
Adhesion cannot be guaranteed
unless cleaner 450.091 has been
used as a pre-treatment.

Artikel in Abhängigkeit der
Füllelementstärken

Articles en fonction de l'éléments
de remplissage

Items depending on thickness
of infill elements

Füllelementstärken Epaisseurs d'élément de remplissage Infill unit thicknesses	Befestigungsanker Boulon-support Supporting bolt					Gewindestift Vis de serrage Set screw			Glasauflage Support de vitrage Glass support								
F* mm	452.587	452.588	452.589	452.590	452.591	452.594	452.595	452.596	452.222	452.223	452.224	452.561	452.562	452.564	452.566	452.567	452.569
15	●					●			●								
16 - 20	●						●			●							
21 - 25		●				●					●						
26 - 30		●					●					●					
31 - 35		●						●					●				
36 - 40			●			●								●			
41 - 45			●				●								●		
46 - 50			●					●								●	
51 - 55				●		●											●
56 - 60				●			●										
61 - 65				●				●									
66 - 70					●			●									

* Sonderlösung Glasauflagen (Flachstahl 10x100 mm)
* Solution spéciale supports de verre (acier plat 10x100 mm)
* Customised solution glazing supports (flat steel 10x100 mm)

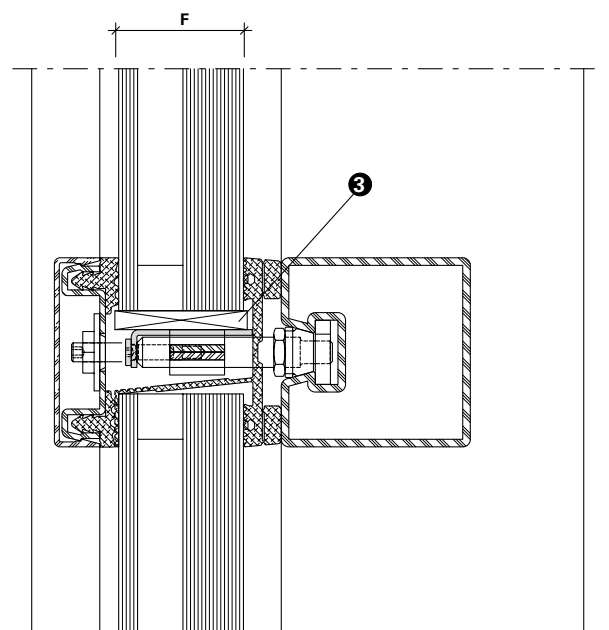
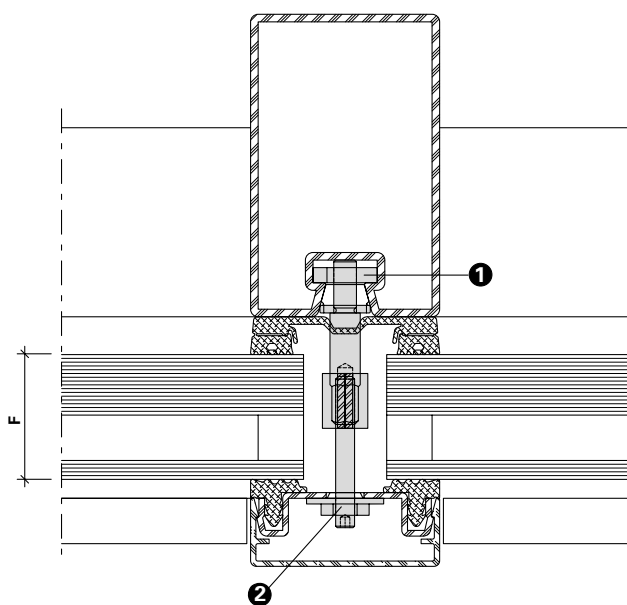

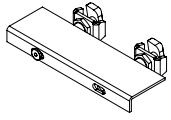

452.222	15 mm
452.223	16 - 20 mm
452.224	21 - 25 mm
452.561	26 - 30 mm
452.562	31 - 35 mm
452.564	36 - 40 mm
452.566	41 - 45 mm
452.567	46 - 50 mm
452.569	51 - 55 mm

Glasauflage
Edelstahl

VE = 20 Stück

Einsatz siehe Seite 51-23

452.222	15 mm
452.223	16 - 20 mm
452.224	21 - 25 mm
452.561	26 - 30 mm
452.562	31 - 35 mm
452.564	36 - 40 mm
452.566	41 - 45 mm
452.567	46 - 50 mm
452.569	51 - 55 mm

Support de vitrage
acier Inox

UV = 20 pièces

Utilisation voir page 51-23

452.222	15 mm
452.223	16 - 20 mm
452.224	21 - 25 mm
452.561	26 - 30 mm
452.562	31 - 35 mm
452.564	36 - 40 mm
452.566	41 - 45 mm
452.567	46 - 50 mm
452.569	51 - 55 mm

Glass support
stainless steel

PU = 20 pieces

Application see page 51-23

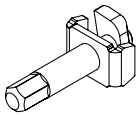

452.587	15 - 20 mm
452.588	21 - 35 mm
452.589	36 - 50 mm
452.590	51 - 65 mm
452.591	66 - 70 mm

Befestigungsanker
Edelstahl

VE = 50 Stück

Einsatz siehe Seite 51-23

452.587	15 - 20 mm
452.588	21 - 35 mm
452.589	36 - 50 mm
452.590	51 - 65 mm
452.591	66 - 70 mm

Boulon-support
acier Inox

UV = 50 pièces

Utilisation voir page 51-23

452.587	15 - 20 mm
452.588	21 - 35 mm
452.589	36 - 50 mm
452.590	51 - 65 mm
452.591	66 - 70 mm

Supporting bolt
stainless steel

PU = 50 pieces

Application see page 51-23

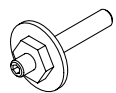

452.594	Länge 30 mm
452.595	Länge 35 mm
452.596	Länge 40 mm

Gewindestift
Edelstahl

VE = 50 Stück

Einsatz Gewindestift:
siehe Seite 51-23

452.594	Longueur 30 mm
452.595	Longueur 35 mm
452.596	Longueur 40 mm

Vis de serrage
acier Inox

UV = 50 pièces

Utilisation vis pointeau
voir page 51-23

452.594	Length 30 mm
452.595	Length 35 mm
452.596	Length 40 mm

Set screw
stainless steel

PU = 50 pieces

Application set screw
see page 51-23



453.016	23 mm
453.026	25 mm
453.027	19 mm
453.028	8 mm
453.029	29 mm
453.030	32 mm
453.031	35 mm
453.032	38 mm
453.033	41 mm
453.034	44 mm
453.072	57 mm

Glasklotz

Promatect-H, Länge 80 mm,
imprägniert

VE = 20 Stück

453.016	23 mm
453.026	25 mm
453.027	19 mm
453.028	8 mm
453.029	29 mm
453.030	32 mm
453.031	35 mm
453.032	38 mm
453.033	41 mm
453.034	44 mm
453.072	57 mm

Cale de remplissage

Promatect-H, longueur 80 mm,
imprégné

UV = 20 pièces

453.016	23 mm
453.026	25 mm
453.027	19 mm
453.028	8 mm
453.029	29 mm
453.030	32 mm
453.031	35 mm
453.032	38 mm
453.033	41 mm
453.034	44 mm
453.072	57 mm

Support

Promatect-H, 80 mm length,
moisture-resistant

PU = 20 pieces

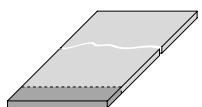

453.070

Glasklotz

glasfaserverstärkter Kunststoff,
100 x 5 mm, Zuschnitt
entsprechend Füllelementstärke
durch Metallbauer

VE = 1 Stück à 1000 mm

453.070

Cale de vitrage

Plastique renforcé par fibres de
verre, 100 x 5 mm, découpe par
le constructeur métallique selon
l'épaisseur des éléments de
remplissage

UV = 1 pièce de 1000 mm

453.070

Glazing bridge

glass fibre reinforced plastic,
100 x 5 mm, to be cut by a
sheet metal worker according to
thickness of the filling material

PU = 1 piece, 1000 mm each



451.017 weiss
451.018 schwarz
Dichtungsband
6x12 mm, selbstklebend
VE = 3 Rollen à 10 m

451.017 3 x 10 m
451.018 3 x 10 m
Bande d'étanchéité
6x12 mm, autocollante
UV = 3 rouleaux à 10 m

451.017 3 x 10 m
451.018 3 x 10 m
Distance strip
6x12 mm, self-adhesive
PU = 3 rollers 10 m each



451.025 weiss
451.035 schwarz
Dichtungsband
6x17 mm, schwer entflammbar,
selbstklebend
VE = 3 Rollen à 10 m

451.025 blanc
451.035 noir
Bande d'étanchéité
6x17 mm, difficilement
combustible, autocollante
UV = 3 rouleaux à 10 m

451.025 white
451.035 black
Distance strip
6x17 mm, flame retardant,
self-adhesive
PU = 3 rollers 10 m each



451.026 weiss
451.036 schwarz
Dichtungsband
8x17 mm, schwer entflammbar,
selbstklebend
VE = 3 Rollen à 10 m

451.026 blanc
451.036 noir
Bande d'étanchéité
8x17 mm, difficilement
combustible, autocollante
UV = 3 rouleaux à 10 m

451.026 white
451.036 black
Distance strip
8x17 mm, flame retardant,
self-adhesive
PU = 3 rollers 10 m each



452.077 8 mm
452.078 10 mm
452.079 12 mm
452.080 15 mm
452.081 20 mm
452.082 25 mm
452.083 30 mm
Ausgleichsprofil
mit doppelseitigem Klebeband,
Haftung auf EPDM und CR,
Länge 1250 mm
VE = 10 Stück

452.077 8 mm
452.078 10 mm
452.079 12 mm
452.080 15 mm
452.081 20 mm
452.082 25 mm
452.083 30 mm
Profilé de compensation
avec ruban adhésif double face,
adhérence sur de l'EPDM et du
CR, longueur 1250 mm
UV = 10 pièces

452.077 8 mm
452.078 10 mm
452.079 12 mm
452.080 15 mm
452.081 20 mm
452.082 25 mm
452.083 30 mm
Spacer profile
with double-sided adhesive tape,
adheres to EPDM and CR,
1250 mm length
PU = 10 pieces



452.030

Universal T-Verbinder

Hülse ø 10 mm, Edelstahl,
Schraube 6,3x38 selbstge-
windend Edelstahl verzinkt

VE = 200 Hülsen
200 Schrauben
(50 T-Verbindungen)

452.030

Raccord Universel en T

douille ø 10 mm, acier Inox,
vis autotaraudeuse 6,3x38 acier
Inox galvanisé

UV = 200 douilles
200 vis
(50 raccords en T)

452.030

Universal connecting spigot

sleeve ø 10 mm, stainless steel,
self-tapping screws 6.3x38
galvanised stainless steel

PU = 200 sleeves
200 screws
(50 connecting spigots)



452.031

Riegel-Befestigungsteil

Stahl verzinkt, Schraube 6,3x38
selbstgewindend aus Edelstahl
verzinkt, Riegel-Schraube
M5x16 aus Edelstahl

VE = 40 Schrauben 6,3x38
20 Riegel-Befestigungsteile
20 Schrauben M5x16
(20 T-Verbindungen)

452.031

Élément de fixation traverse

acier galvanisé, vis autotaraudeuse
6,3x38 en acier Inox
galvanisé, vis de traverse
M5x16 en acier Inox

UV = 40 vis 6,3x38
20 éléments de fixation
traverse
20 vis M5x16
(20 raccords en T)

452.031

Transom fixing component

galvanised steel, galvanised
stainless steel self-tapping
screws 6.3x38, stainless steel
transom screws M5x16

PU = 40 screws 6,3x38
20 transom fixing
components
20 screws M5x16
(20 connecting spigots)



452.033

Riegel-Befestigungsteil M5

Stahl verzinkt, mit vorgefertigtem
M5-Loch, Schraube 6,3x38
selbstgewindend aus Edelstahl
verzinkt, Riegel-Schraube
M5x16 aus Edelstahl

VE = 40 Schrauben 6,3x38
20 Riegel-Befestigungsteile
20 Schrauben M5x16
(20 T-Verbindungen)

452.033

Élément de fixation traverse M5

acier galvanisé, avec trou M5
pré-usiné, vis autotaraudeuse
6,3x38 en acier Inox
galvanisé, vis de traverse
M5x16 en acier Inox

UV = 40 vis 6,3x38
20 éléments de fixation
traverse
20 vis M5x16
(20 raccords en T)

452.033

Transom fixing component M5

galvanised steel, with precut
M5 hole, galvanised stainless
steel self-tapping screws
6.3x38, stainless steel transom
screws M5x16

PU = 40 screws 6,3x38
20 transom fixing
components
20 screws M5x16
(20 connecting spigots)



452.032

Bolzen-Hülse

ø 11 mm, Edelstahl,
für VISS Linea-Profile

VE = 20 Stück

452.032

Douille pour goujon

ø 11 mm, acier Inox,
pour profilés VISS Linea

UV = 20 pièces

452.032

Bolt sleeve

ø 11 mm, stainless steel,
für VISS Linea profiles

PU = 20 pieces



452.060 für Profil 76.696
452.061 für Profil 76.697
452.062 für Profil 76.679
452.063 für Profil 76.666

**Schwerlast-T-Verbinder
einhängbar**

Stahl, Kanten gebrochen,
Ansichtsbreite 50 mm,
Schrauben Edelstahl 1.0569

VE = 5 Garnituren (5 Stück
links, 5 Stück rechts)

*Einbau mit
499.404 / 499.207*

452.060 pour profilé 76.696
452.061 pour profilé 76.697
452.062 pour profilé 76.679
452.063 pour profilé 76.666

**Raccord en T charge lourde
à suspendre**

acier, arêtes brisées, largeur
de face 50 mm, vis en acier
Inox 1.0569

UV = 5 garnitures (5 unités à
gauche, 5 unités à droite)

*Montage avec
499.404 / 499.207*

452.060 for profile 76.696
452.061 for profile 76.697
452.062 for profile 76.679
452.063 for profile 76.666

**Clip-in heavy-duty
connecting spigot**

steel, sharp edges removed,
50 mm face width, stainless
steel screws 1.0569

PU = 5 kits
(5 for left, 5 for right)

*Installation with
499.404 / 499.207*



453.080

Unterlage Pfostenschutz

Zellkautschuk EPDM,
schwarz, zuschneidbar,
einseitig selbstklebend,
Ansichtsbreite 50 mm

VE = 20 Stück

453.080

Cale protection du montant

caoutchouc cellulaire EPDM,
noir, découpable, autocollant
d'un seul côté,
largeur de face 50 mm

UV = 20 pièces

453.080

Mullion protection support

EPDM closed cell foam,
black, can be cut to size,
one-sided selfadhesive,
50 mm face width

PU = 20 pieces



452.070 für Profil 76.678
452.071 für Profil 76.684
452.072 für Profil 76.698
452.073 für Profil 76.667
452.074 für Profil 76.140 Z
452.075 für Profil 76.141 Z
452.076 für Profil 76.142 Z

**Schwerlast-T-Verbinder
einhängbar**

Stahl, Kanten gebrochen,
Ansichtsbreite 60 mm,
Schrauben Edelstahl 1.0569

VE = 5 Garnituren (5 Stück
links, 5 Stück rechts)

*Einbau mit
499.405 bzw. 499.010 / 499.208*

452.070 pour profilé 76.678
452.071 pour profilé 76.684
452.072 pour profilé 76.698
452.073 pour profilé 76.667
452.074 pour profilé 76.140 Z
452.075 pour profilé 76.141 Z
452.076 pour profilé 76.142 Z

**Raccord en T charge lourde
à suspendre**

acier, arêtes brisées, largeur
de face 60 mm, vis en acier
Inox 1.0569

UV = 5 garnitures (5 unités à
gauche, 5 unités à droite)

*Montage avec
499.405 resp. 499.010 / 499.208*

452.070 for profile 76.696
452.071 for profile 76.684
452.072 for profile 76.698
452.073 for profile 76.667
452.074 for profile 76.140 Z
452.075 for profile 76.141 Z
452.076 for profile 76.142 Z

**Clip-in heavy-duty
connecting spigot**

steel, sharp edges removed,
60 mm face width, stainless
steel screws 1.0569

PU = 5 kits
(5 for left, 5 for right)

*Installation with
499.405 resp. 499.010 / 499.208*



453.081

Unterlage Pfostenschutz
Zellkautschuk EPDM,
schwarz, zuschneidbar,
einseitig selbstklebend,
Ansichtsbreite 60 mm

VE = 20 Stück

453.081

Cale protection du montant
caoutchouc cellulaire EPDM,
noir, découpable, autocollant
d'un seul côté,
largeur de face 60 mm

UV = 20 pièces

453.081

Mullion protection support
EPDM closed cell foam,
black, can be cut to size,
one-sided selfadhesive,
60 mm face width

PU = 20 pieces



453.083

Unterlage Pfostenschutz
Zellkautschuk EPDM,
schwarz, zuschneidbar,
einseitig selbstklebend,,
Ansichtsbreite 60 mm

VE = 20 Stück

Einsatz:
452.074, 452.075, 452.076

453.083

Cale protection du montant
caoutchouc cellulaire EPDM,
noir, découpable, autocollant
d'un seul côté,
largeur de face 60 mm

UV = 20 pièces

Utilisation:
452.074, 452.075, 452.076

453.083

Mullion protection support
EPDM closed cell foam,
black, can be cut to size,
one-sided selfadhesive,
60 mm face width

PU = 20 pieces

Application:
452.074, 452.075, 452.076

Verarbeitungshilfen

Outils d'usinage

Assembly tools

VISS Fire EI30 Fassade/Trennwand

VISS Fire EI30 façade/cloison

VISS Fire EI30 façade/partition wall



499.006

2 mm Sechskant-Bit
zum Eindrehen der
Gewindestifte

VE = 2 Stück

499.006

Embout de tournevis
6-pans 2 mm
pour visser les vis sans tête

UV = 2 pièces

499.006

2 mm hexagonal bit
for inserting set screws

PU = 2 pieces



499.009

Schraubklingen
mit SR1-Angriff

VE = 3 Stück

499.009

Embout de tournevis
avec tête spéciale SR1

UV = 3 pièces

499.009

Blades
for SR1-head screws

PU = 3 pieces



499.254

Werkzeugset

VE = 1 Steckschlüssel SW 11
1 Positionierhilfe 25 mm
1 Positionierhilfe 32 mm

499.254

Jeu d'outils

UV = 1 clé à pipe SW 11
1 aide de réglage 25 mm
1 aide de réglage 32 mm

499.254

Tool kit

PU = 1 box spanner size 11
1 positioning aid 25 mm
1 positioning aid 32 mm



499.206

Abziehhebel
für die Demontage der
aufgeklipsten Abdeckprofile

VE = 1 Stück

499.206

Levier de démontage
pour le démontage des profilés
de recouvrement clipsés

UV = 1 pièce

499.206

Stripping lever
for disassembly of the clipped
on cover profile

PU = 1 piece



499.263

Dichtungsschere Kreuzpunkt
zum Ausklinken der vertikalen
Innendichtung

VE = 1 Stück

499.263

Ciseaux à joints point
d'intersection
pour entailler le joint intérieur
vertical

UV = 1 pièce

499.263

Gasket shears for the
intersection point
for notching the vertical
inner gasket

UV = 1 piece

Verlangen Sie für die Verarbeitung
und Montage der VISS-Systeme
unsere ausführlichen Verarbeitungs-
und Montage-Richtlinien.

Demandez notre brochure détaillée
sur les directives d'usinage et de
montage du systèmes VISS.

For processing and assembling the
VISS systems, ask for our detailed
Fabrication and Assembly
Instructions.



499.264

Dichtungsschere Endpunkt
zum Ausklinken der horizontalen
Innendichtung

VE = 1 Stück

499.264

Ciseaux à joints extrémité
pour entailler le joint intérieur
horizontal

UV = 1 pièce

499.264

Gasket shears for the end point
for notching the horizontal inner
gasket

PU = 1 piece



499.266

Dichtungsstanze
zum Ausklinken der
horizontalen Innendichtung

VE = 1 Stück

499.266

Poinçon à joints
pour entailler le joint intérieur
horizontal

UV = 1 pièce

499.266

Gasket punch
for notching the horizontal
inner gasket

PU = 1 piece



499.267

Austauschset
Das Austauschset ermöglicht das
Aufrüsten der alten Dichtungs-
stanze 499.253 auf den Stand der
neuen Dichtungsstanze 499.266.
Die Adaption beinhaltet einen
Auswurfmechanismus für die
Dichtung sowie einen Schnittschutz.

VE = 1 Stück

499.267

Kit de remplacement
Le kit de remplacement permet
de remplacer l'ancien poinçon
à joints 499.253 par le nouveau
poinçon à joints 499.266. L'adap-
tation comprend un mécanisme
d'éjection du joint ainsi qu'une
protection anticoupures.

UV = 1 pièce

499.267

Replacement kit
The replacement kit allows the
old gasket punch 499.253 to be
upgraded to the standard of the
new gasket punch 499.266. The
adaptation includes an ejection
mechanism for the gasket and
cut protection.

PU = 1 piece



499.262

Ausstanzset
zum Ausklinken der horizontalen
Innendichtung für Flachstahl-
Glasauflagen.

VE = 1 Stück

499.262

Kit de découpage
pour entailler le joint intérieur
horizontal des supports de
vitrage en acier plat.

UV = 1 pièce

499.262

Punching kit
for notching the horizontal
inner gasket for flat steel
glazing supports.

PU = 1 piece

VISS DV
Artikel in Abhängigkeit der
Füllelementstärken

VISS Dv
Articles en fonction de l'éléments
de remplissage

VISS DV
Items depending on thickness
of infill elements

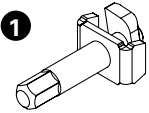
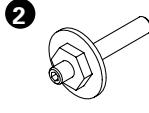
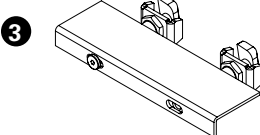
Füllelementstärken Epaisseurs d'élément de remplissage Infill unit thicknesses	Befestigungsanker Boulon-support Supporting bolt					Gewindestift Vis de serrage Set screw			Glasauflage Support de vitrage Glass support							
																
F* mm	452.587	452.588	452.589	452.590	452.591	452.594	452.595	452.596	452.222	452.223	452.224	452.561	452.562	452.564	452.566	452.567
15 - 19	●					●			●							
20 - 24	●						●			●						
25 - 29		●				●					●					
30 - 34		●					●					●				
35 - 39		●						●					●			
40 - 44			●			●								●		
45 - 49			●				●								●	
50 - 54			●					●								●
55 - 59				●		●			* Sonderlösung Glasauflagen (Flachstahl 10x100 mm) * Solution spéciale supports de verre (acier plat 10x100 mm) * Customised solution glazing supports (flat steel 10x100 mm)							
60 - 64				●			●									
65 - 69				●			●									
70					●		●									

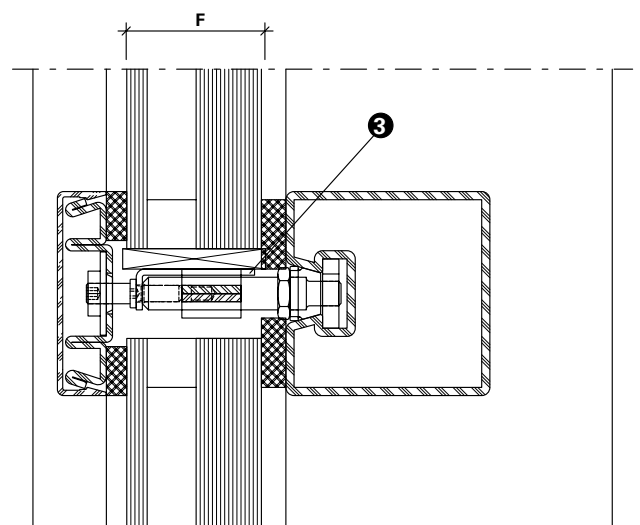
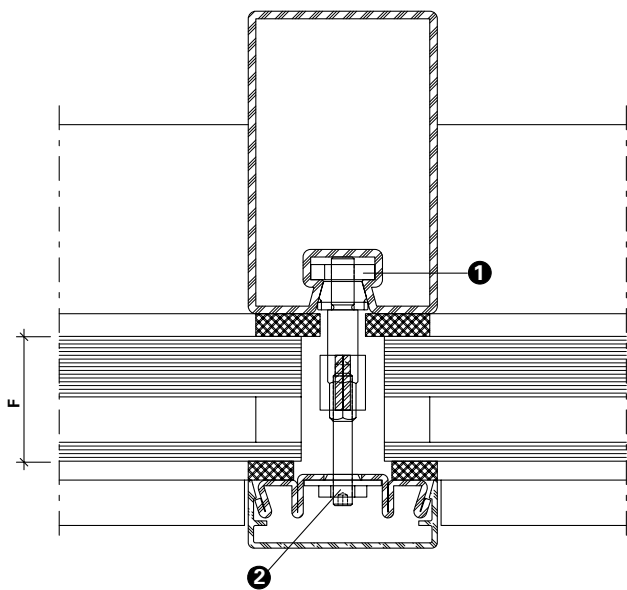



452.222	15 - 19 mm
452.223	20 - 24 mm
452.224	25 - 29 mm
452.561	30 - 34 mm
452.562	35 - 39 mm
452.564	40 - 44 mm
452.566	45 - 49 mm
452.567	50 - 54 mm

Glasauflage

Edelstahl 1.4305, mit Anker und Befestigungsschraube M4x10, Auflegewinkel mit Klebefolie für Montage Glasklotz, mit Innengewinde M4

VE = 20 Stück

Einsatz:
siehe Seite 51-32

452.222	15 - 19 mm
452.223	20 - 24 mm
452.224	25 - 29 mm
452.561	30 - 34 mm
452.562	35 - 39 mm
452.564	40 - 44 mm
452.566	45 - 49 mm
452.567	50 - 54 mm

Support de verre

acier Inox 1.4305, avec boulon d'ancrage et vis de fixation M4x10, cornière d'appui avec bande adhésive pour montage cale de vitrage, avec filetage intérieur M4

UV = 20 pièces

Utilisation:
voir page 51-32

452.222	15 - 19 mm
452.223	20 - 24 mm
452.224	25 - 29 mm
452.561	30 - 34 mm
452.562	35 - 39 mm
452.564	40 - 44 mm
452.566	45 - 49 mm
452.567	50 - 54 mm

Glazing support

stainless steel 1.4305, with anchor and fastening screw M4x10, angle support with adhesive foil for installation glazing bridge, with internal thread M4

PU = 20 pieces

Application:
see page 51-32

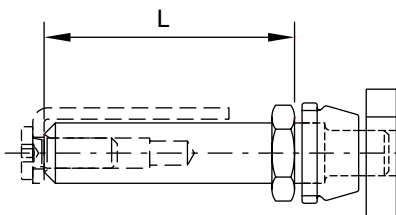

452.587	15-24 mm
452.588	25-39 mm
452.589	40-54 mm
452.590	55-69 mm
452.591	70 mm

Brandschutzanker

Edelstahl, mit vormontiertem Keil und Nutenstein

VE = 50 Stück

Einsatz:
siehe Seite 51-32

452.587	15-24 mm
452.588	25-39 mm
452.589	40-54 mm
452.590	55-69 mm
452.591	70 mm

Boulon d'ancrage anti-incendie

acier Inox, avec cale et languette montées au préalable

UV = 50 pièces

Utilisation:
voir page 51-32

452.587	F = 15-24 mm
452.588	F = 25-39 mm
452.589	F = 40-54 mm
452.590	F = 55-69 mm
452.591	F = 70 mm

Fire-proof anchor

stainless steel, with pre-assembled key and tenon block

PU = 50 pieces

Application:
see page 51-32



452.594 Länge 30 mm
452.595 Länge 35 mm
452.596 Länge 40 mm

Gewindestift
mit Mutter und Gewindestift, zur
Befestigung des Anpressprofils

VE = 50 Stück

Einsatz:
siehe Seite 51-32

452.594 Longueur 30 mm
452.595 Longueur 35 mm
452.596 Longueur 40 mm

Vis de serrage
avec écrou et vis sans tête, pour
la fixation du profilé de fixation

UV = 50 pièces

Utilisation:
voir page 51-32

452.594 Length 30 mm
452.595 Length 35 mm
452.596 Length 40 mm

Set screw
with nut and grub screw, for
fixing the pressure plate

PU = 50 pieces

Application:
see page 51-32

Vorhangfassade	Façade de rideau	Curtain wall	36
Verglasungstypen	Types de vitrages	Glazing types	38
Brandschutz-Paneele	Panneaux coupe-feu	Fire resistant panels	40
Schnittpunkte	Coupe de détails	Section details	42
Konstruktionsdetails	Détails de construction	Construction details	49
Anschlüsse am Bau	Raccords au mur	Attachment to structure	57
Konstruktionsdetails	Détails de construction	Construction details	102
Glaseinstand	Prise en feuillure	Glass edge cover	103
Befestigungsarten	Méthode de fixation	Fastening types	105
U_{cw}-Werte	Valeurs U_{cw}	U_{cw} values	111

Vorhangfassade
Ansicht von aussen

Façade rideau
Vue de l'extérieur

Curtain wall
View from outside

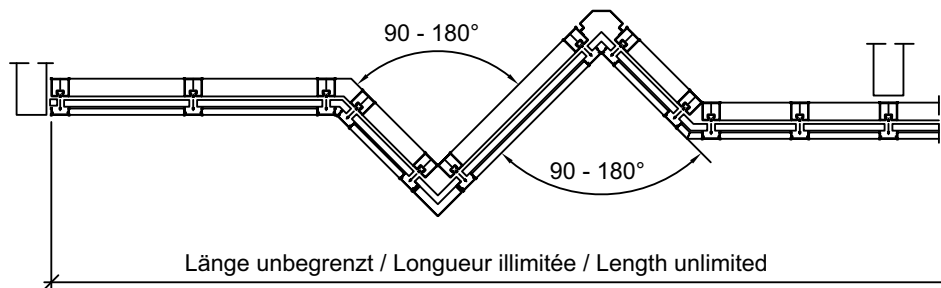
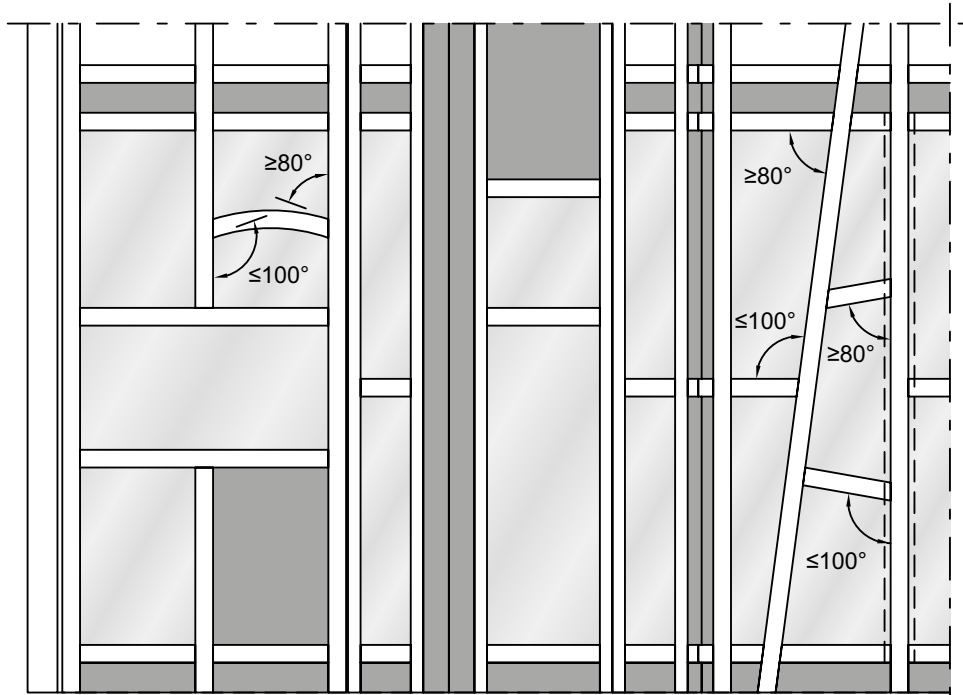
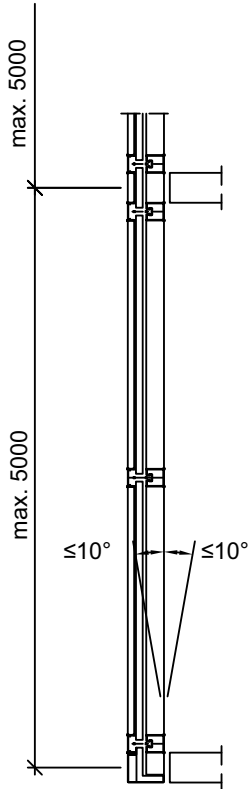

Türeinbau und Abmessungen
 siehe nationale Zulassungen
 und Klassifizierungsbericht
 13-003089-PR01.

Montage et dimensions de la porte,
 voir les approbations nationales
 et le rapport de classification
 13-003089-PR01.

Door installations and dimensions,
 see national approvals and
 classification report 13-003089-PR01.

Trennwand
Ansicht von aussen

Cloison
Vue de l'extérieur

Separation wall
View from outside

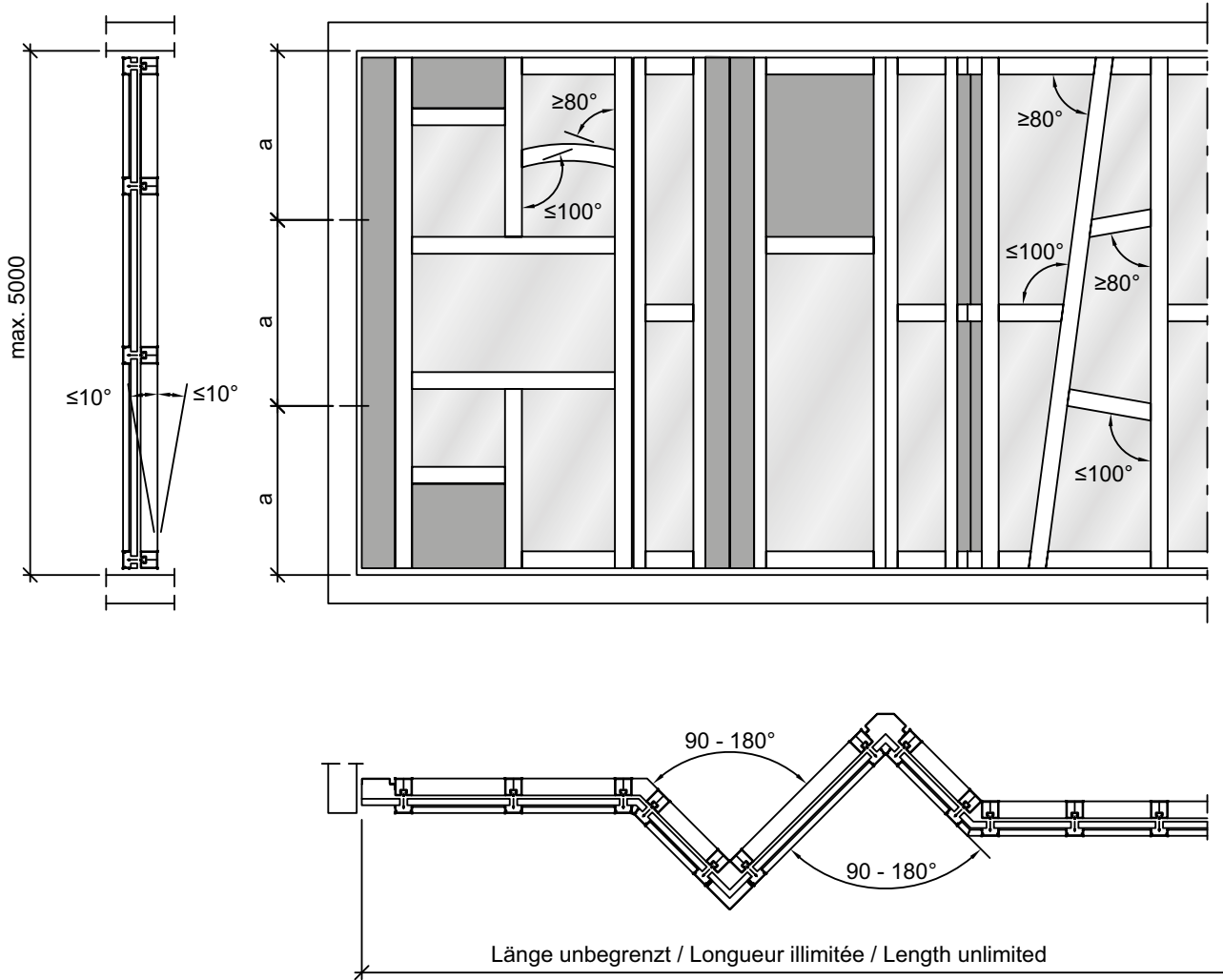

Türeinbau und Abmessungen
 siehe nationale Zulassungen
 und Klassifizierungsbericht
 13-003089-PR01.

Montage et dimensions de la porte,
 voir les approbations nationales
 et le rapport de classification
 13-003089-PR01.

Door installations and dimensions,
 see national approvals and
 classification report 13-003089-PR01.

Verglasungstypen

Types de vitrages

Glazing types

Einfach-Verglasung
Vitrage simple
Simple glass

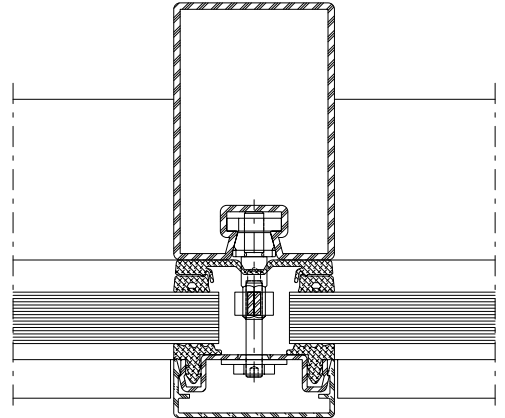
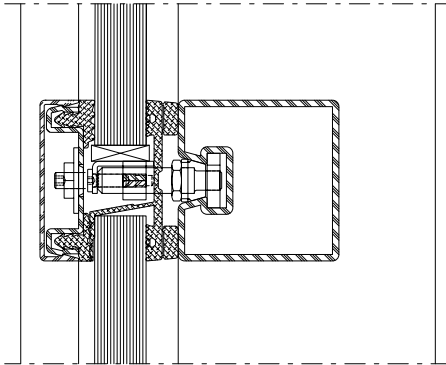

Zweifach-Isolierverglasung
Double vitrage isolant
Double glazing

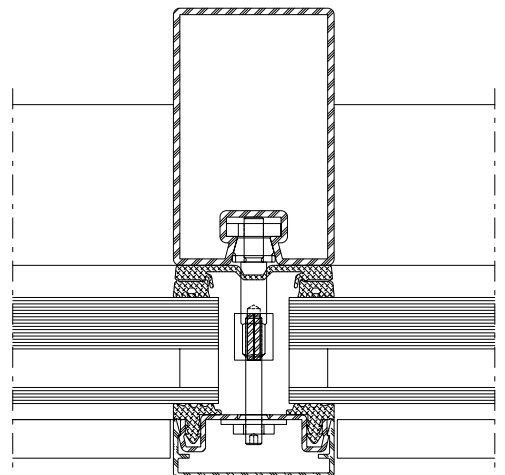
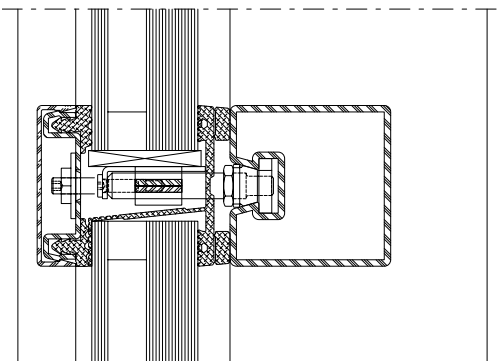

Dreifach-Isolierverglasung
Triple vitrage isolant
Triple glazing

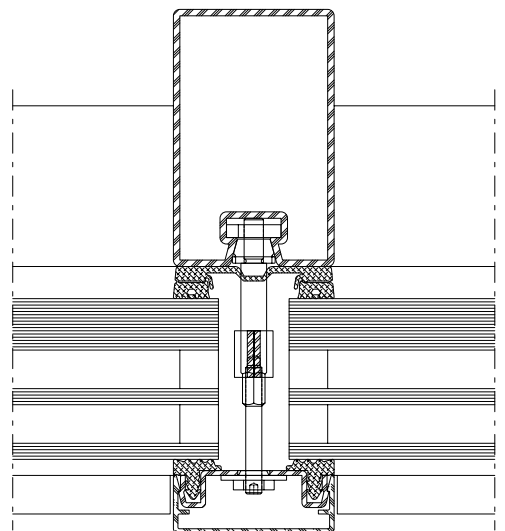
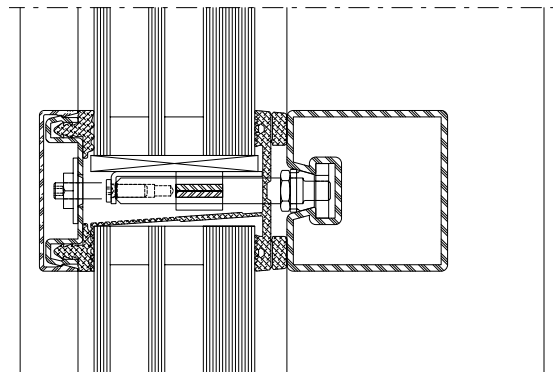

Verglasungstypen VISS DV

Types de vitrages VISS DV

Glazing types

Nassverglasung mit Silikon
Vitrage avec silicone
Wet glazing with silicone

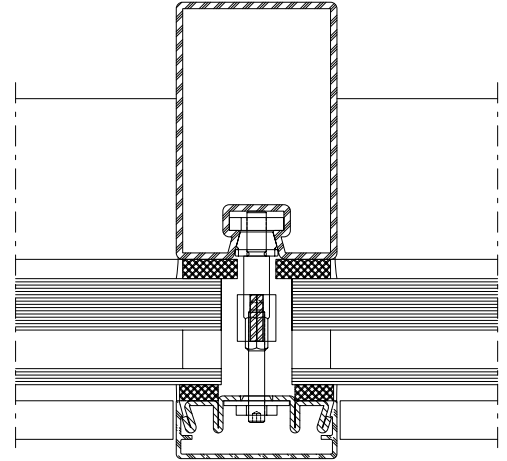
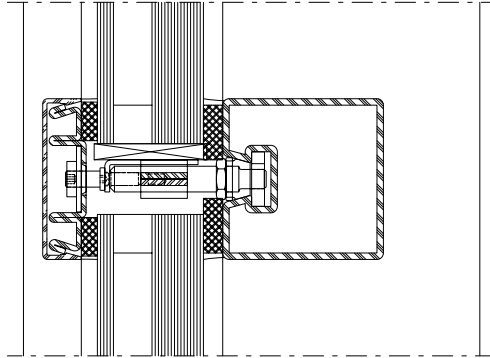

Nassverglasung ohne Silikon
Vitrage sans silicone
Wet glazing without silicone

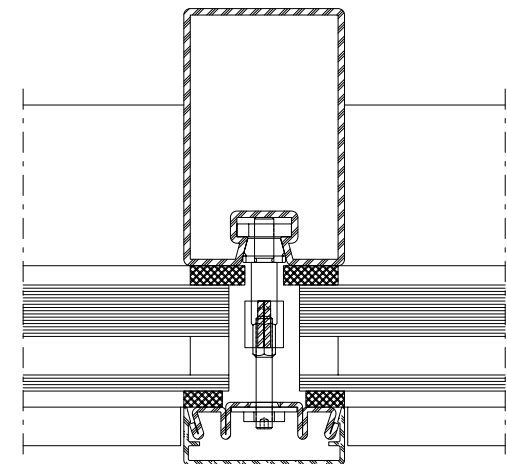
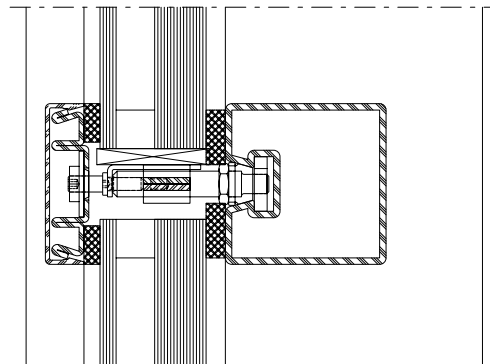

Brandschutz-Paneele

Panneaux coupe-feu

Fire resistant panels

Typ 7.5.1

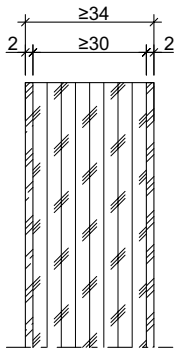

Typ 7.5.2

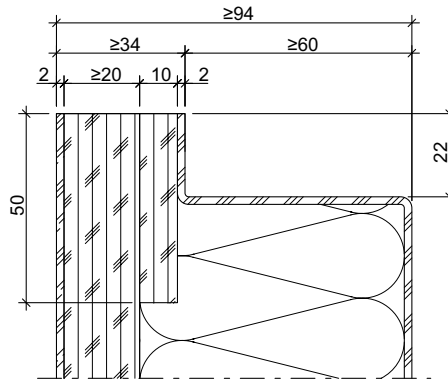

Typ 7.5.3

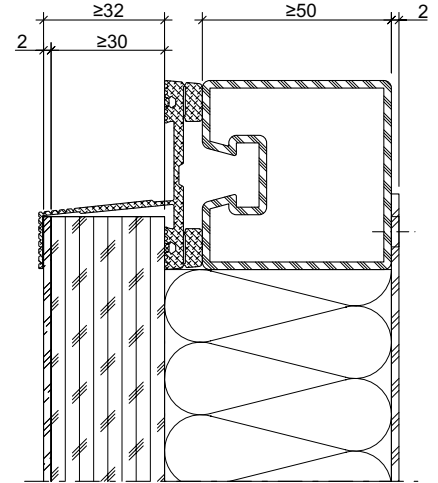

Typ 7.5.4

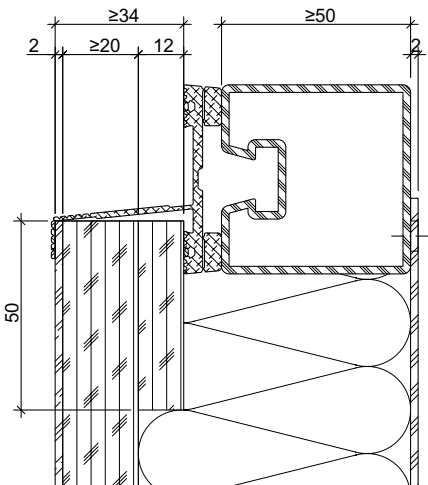

Typ 7.5.5

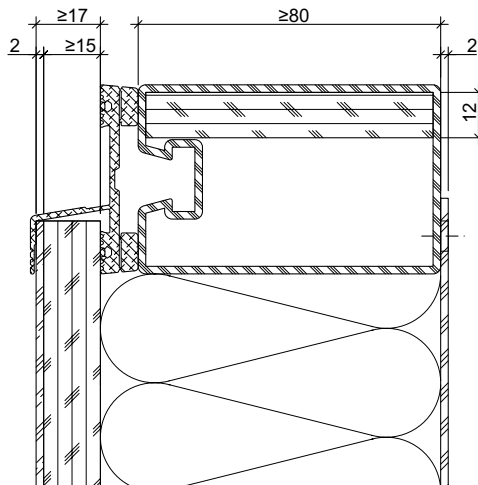

Typ 7.5.6

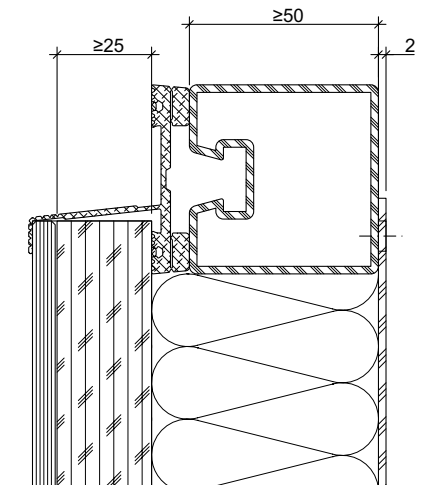

Paneelaufbau

Paneelabdeckung Aussenseite:
 Metall ≤ 3 mm
 Stein, Beton, Glas

Paneelabdeckung Innenseite:
 Stahlblech 2 mm

Kern:
 Aestuver Brandschutzplatte
 Mineralwolle ≥ 60 kg/m³

Kleber:
 Klebmasse 452.084

Dampfsperrband:
 Aluminiumband

Composition du panneau

Cache panneau extérieur:
 Métal ≤ 3 mm
 Pierre, béton ou verre

Cache panneau intérieur:
 Tôle en acier 2 mm

Couche intermédiaire:
 Aestuver plaque coupe-feu
 Laine minérale ≥ 60 kg/m³

Colle:
 Pâte à coller 452.084

Bande par-vapeur:
 Feuille d'aluminium

Panel composition

Panel cover outside:
 Metal ≤ 3 mm
 Stone, concrete, glass

Panel cover inside:
 Metal sheet 2 mm

Core:
 Aestuver fire protection board
 Mineral wool ≥ 60 kg/m³

Glue:
 Bonding compound 452.084

Tape vapor barrier:
 Aluminium tape

Pos.	Material	Matériaux	Material
1*	Mineralwolle $\geq 60 \text{ kg/m}^3$ Flumroc Dämmplatte 3 Flumroc Bodenplatte Rockwool Fixrock 033 Rockwool Fixrock 033LB	Laine minérale $\geq 60 \text{ kg/m}^3$ Flumroc Plaque isolante 3 Flumroc Plaque de fons Rockwool Fixrock 033 Rockwool Fixrock 033LB	Mineral wool $\geq 60 \text{ kg/m}^3$ Flumroc Insulation panel 3 Flumroc Base plate Rockwool Fixrock 033 Rockwool Fixrock 033LB
2	Aestuver Brandschutzplatte	Aestuver plaque coupe-feu	Aestuver fire protection board
3	Stahl- oder Edelstahlblech $\geq 1,5 \text{ mm}$	Tôle en acier ou acier inox $\geq 1,5 \text{ mm}$	Steel or stainless steel sheet $\geq 1,5 \text{ mm}$
4	Stahl- oder Edelstahlblech $\geq 2 \text{ mm}$	Tôle en acier ou acier inox $\geq 2 \text{ mm}$	Steel or stainless steel sheet $\geq 2 \text{ mm}$
5	Stahl- oder Edelstahlblech $\geq 3 \text{ mm}$	Tôle en acier ou acier inox $\geq 3 \text{ mm}$	Steel or stainless steel sheet $\geq 3 \text{ mm}$
6	Stahl- oder Edelstahlblech $\geq 4 \text{ mm}$	Tôle en acier ou acier inox $\geq 4 \text{ mm}$	Steel or stainless steel sheet $\geq 4 \text{ mm}$
7	Aluminiumblech $\geq 1,5 \text{ mm}$	Tôle en aluminium $\geq 1,5 \text{ mm}$	Aluminium sheet $\geq 1,5 \text{ mm}$
8	Formstahl $\geq 4 \text{ mm}$	Profilé d'acier $\geq 4 \text{ mm}$	Steel profile $\geq 4 \text{ mm}$
9	Formstahl $\geq 5 \text{ mm}$	Profilé d'acier $\geq 5 \text{ mm}$	Steel profile $\geq 5 \text{ mm}$
10	Formstahl $\geq 10 \text{ mm}$	Profilé d'acier $\geq 10 \text{ mm}$	Steel profile $\geq 10 \text{ mm}$
11	Stahlwinkel 40x40x5 mm	Angle en acier 40x40x5 mm	Steel angle 40x40x5 mm
12	Stahlrohr $\geq 2 \text{ mm}$	Tube d'acier $\geq 2 \text{ mm}$	Steel tube $\geq 2 \text{ mm}$
13	Schraube mit Dübel oder Direktverschraubung, $\varnothing \geq 6 \text{ mm}$, mit Brandschutz-Zulassung	Vis avec goujon ou autotaraudeuse, $\varnothing \geq 6 \text{ mm}$, avec homologation coupe-feu	Screw with anchor or direct screwing, $\varnothing \geq 6 \text{ mm}$, with fire protection approval
14	Schraube, Blindniete oder Lochschweissung	Vis, rivet aveugle, soudure bouchon	Screw, blind rivet or plug welding
15	Stahlschraube $\geq \text{M8}$	Boulon en acier $\geq \text{M8}$	Steel screw $\geq \text{M8}$
16	Senkschraube ISO 7046-1, M5x12	Vis à tête fraisée ISO 7046-1, M5x12	Countersunk screw ISO 7046-1, M5x12
17	Zylinderschraube ISO 4762, M5x16	Vis à tête cylindrique ISO 4762, M5x16	Cylinder head screw ISO 4762, M5x16
18	Sechskantschraube ISO4017, M8	Vis à tête hexagonale ISO4017, M8	Hexagonal bolt ISO4017, M8
19	Macroplast UK8101/UK5400 (Kleber)	Macroplast UK8101/UK5400 (colle)	Macroplast UK8101/UK5400 (glue)
20	Illbruck ME501 Twin Aktiv HI mit Illbruck SP025 Kleber	Illbruck ME501 Twin Aktiv HI avec colle Illbruck SP025	Illbruck ME501 Twin Aktiv HI with Illbruck SP025 glue
21	Terofol sd3 mit Terotech KDS Kleber	Terofol sd3 avec colle Terotech KDS	Terofol sd3 with Terotech KDS glue
22	Terofol sd150	Terofol sd150	Terofol sd150
23	PE-Stopfschnur	PE Cordon de bourrage	PE-Joint backer rod
24	Rundstahl $\varnothing 16 \text{ mm}$	Acier rond $\varnothing 16 \text{ mm}$	Round steel $\varnothing 16 \text{ mm}$
25	Formstahl $\geq 8 \text{ mm}$	Profilé d'acier $\geq 8 \text{ mm}$	Steel profile $\geq 8 \text{ mm}$
26	Formstahl $\geq 3 \text{ mm}$	Profilé d'acier $\geq 3 \text{ mm}$	Steel profile $\geq 3 \text{ mm}$
27	Senkblechschraube $\varnothing 4,2$	Vis à tôle à tête fraisée $\varnothing 4,2$	Countersunk haed tapping screw $\varnothing 4,2$
28	Senkschraube M5	Vis à tête fraisée M5	Countersunk screw M5
29	Stahlrohr $\geq 1,5 \text{ mm}$	Tube d'acier $\geq 1,5 \text{ mm}$	Steel tube $\geq 1,5 \text{ mm}$
30	Distanzband EPDM geschäumt, 15x3 mm	Bande d'écartement EPDM moussée, 15x3 mm	Packing tape EPDM foamed, 15x3 mm

* ausschliesslich erlaubt

* exclusivement autorisé

* exclusively permitted

Schnittpunkte im Massstab 1:1
Coupe de détails à l'échelle 1:1
Section details on scale 1:1

VISS Fire EI30 Fassade/Trennwand
VISS Fire EI30 façade/cloison
VISS Fire EI30 façade/partition wall

Pfosten-Detail
Ansichtsbreite 50 mm

Détail du montant
Largeur de face 50 mm

Detail of mullion
Width 50 mm

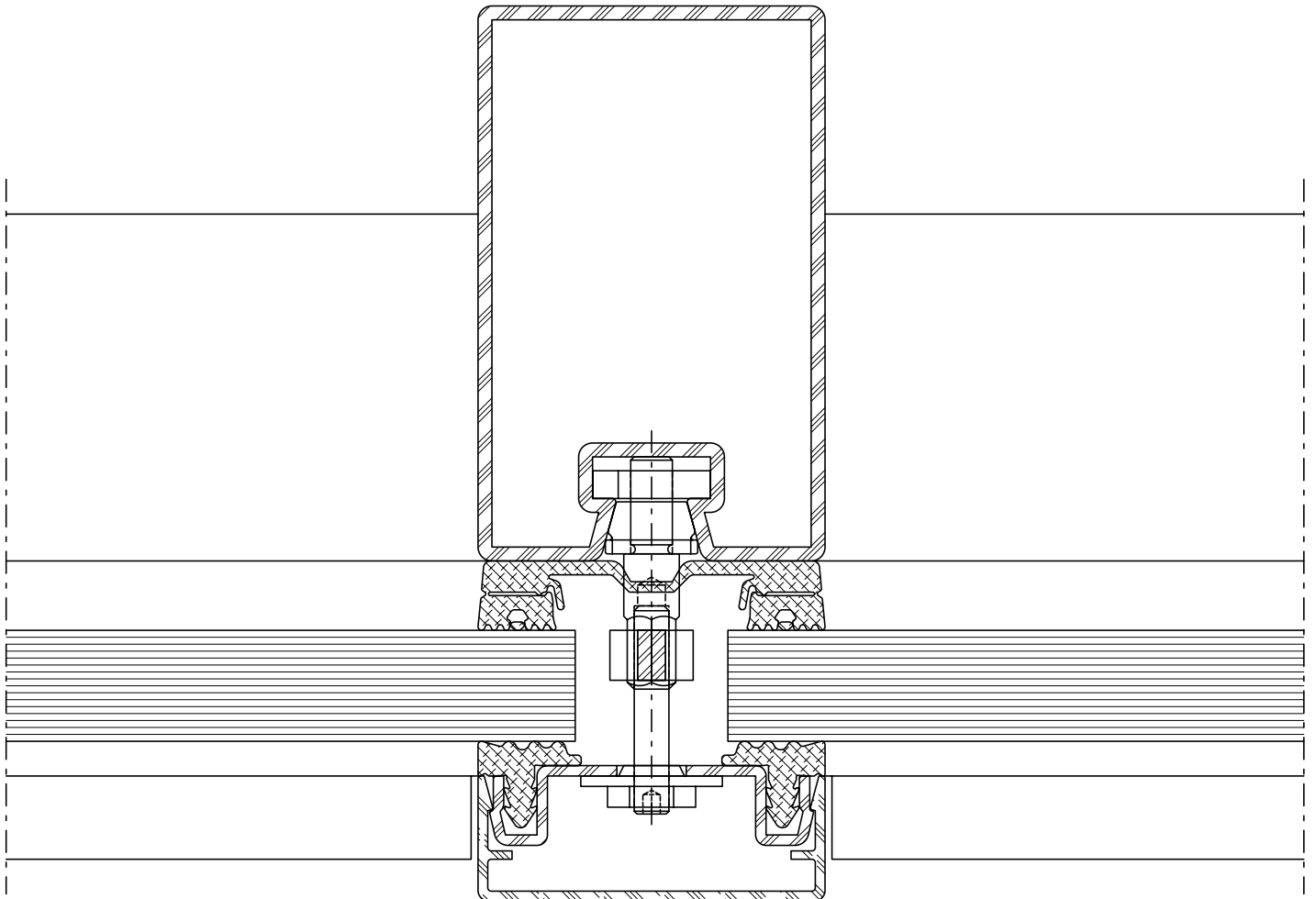

DXF

DWG

51-0501-C-002

Schnittpunkte im Massstab 1:1
Coupe de détails à l'échelle 1:1
Section details on scale 1:1

VISS Fire EI30 Fassade/Trennwand
VISS Fire EI30 façade/cloison
VISS Fire EI30 façade/partition wall

Riegel-Detail
Ansichtsbreite 50 mm

Détail de la traverse
Largeur de face 50 mm

Detail of transom
Width 50 mm

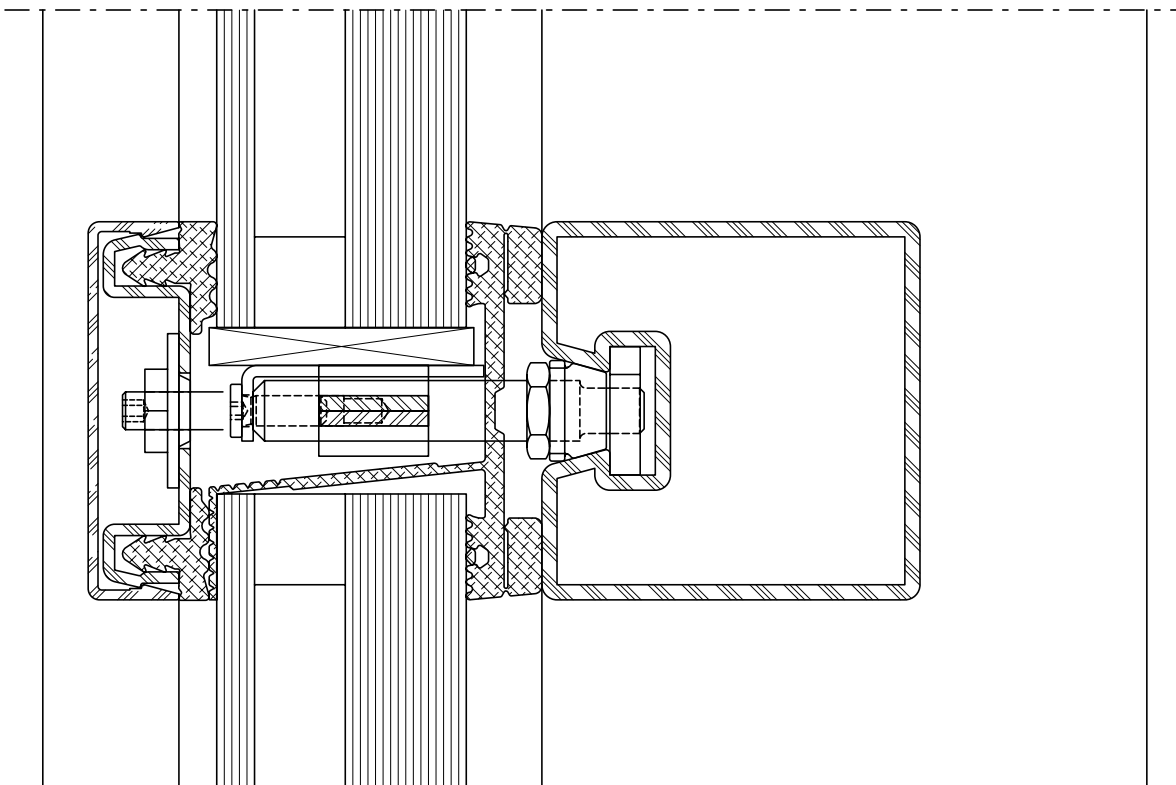
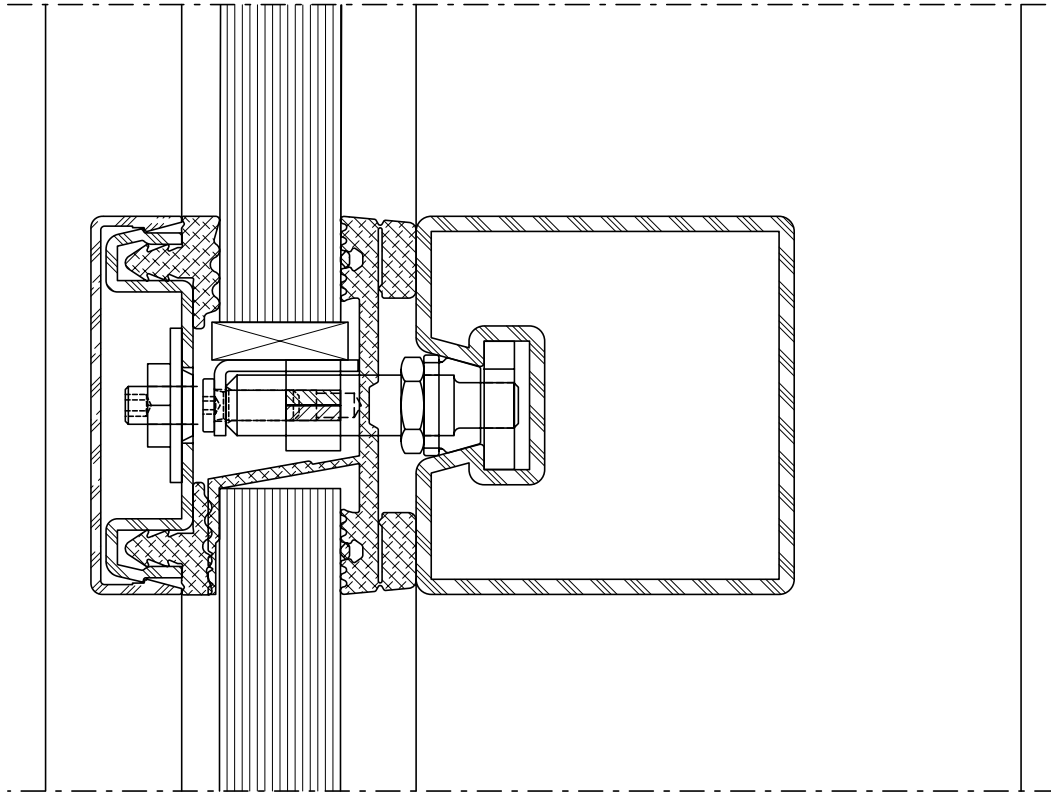

Schnittpunkte im Massstab 1:1
Coupe de détails à l'échelle 1:1
Section details on scale 1:1

VISS Fire EI30 Fassade/Trennwand
VISS Fire EI30 façade/cloison
VISS Fire EI30 façade/partition wall

Pfosten-Detail
Ansichtsbreite 50 mm

Détail du montant
Largeur de face 50 mm

Detail of mullion
Width 50 mm

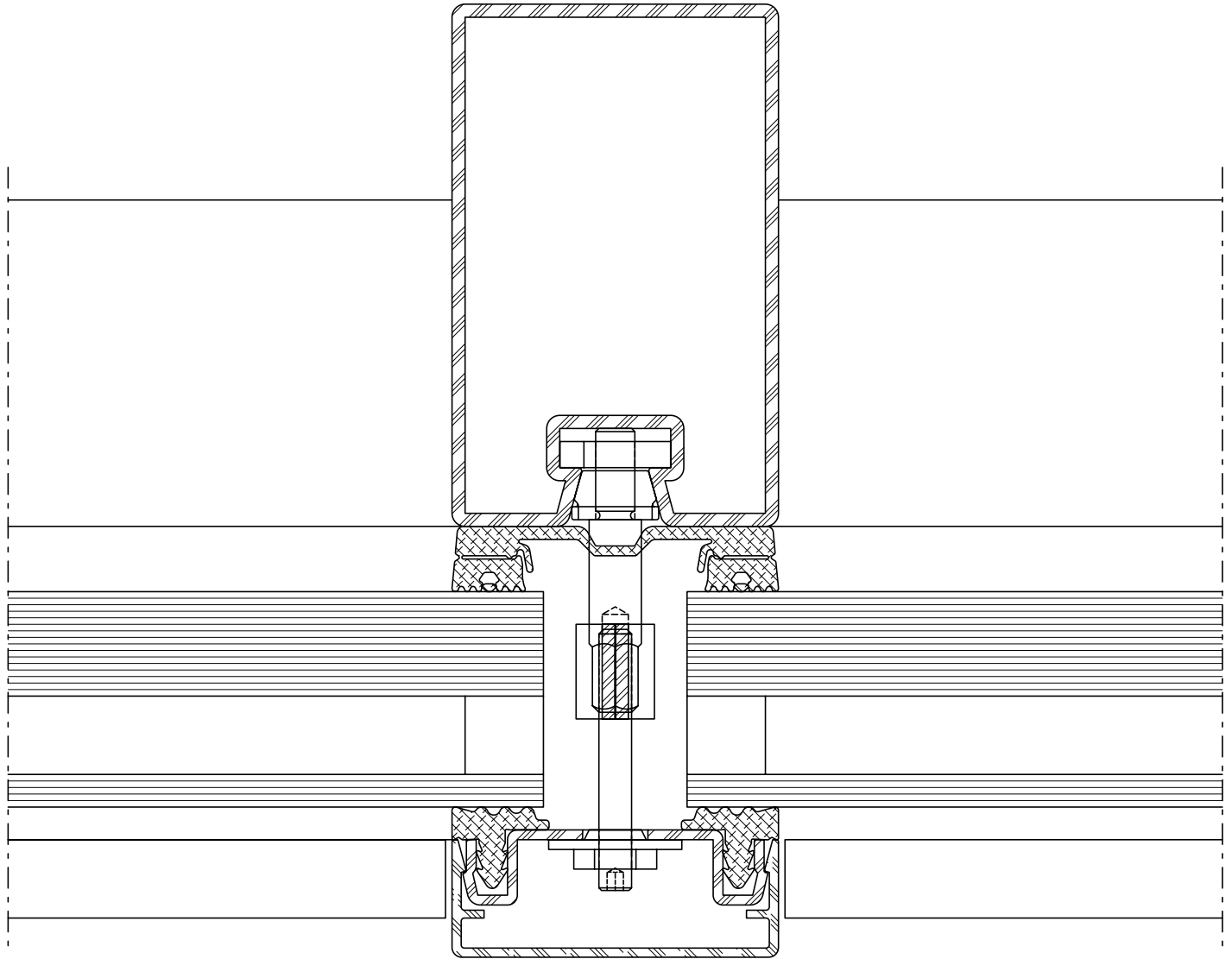

DXF

DWG

51-0501-C-004

Schnittpunkte im Massstab 1:1
Coupe de détails à l'échelle 1:1
Section details on scale 1:1

VISS Fire EI30 Fassade/Trennwand
VISS Fire EI30 façade/cloison
VISS Fire EI30 façade/partition wall

Riegel-Detail
Ansichtsbreite 50 mm

Détail de la traverse
Largeur de face 50 mm

Detail of transom
Width 50 mm

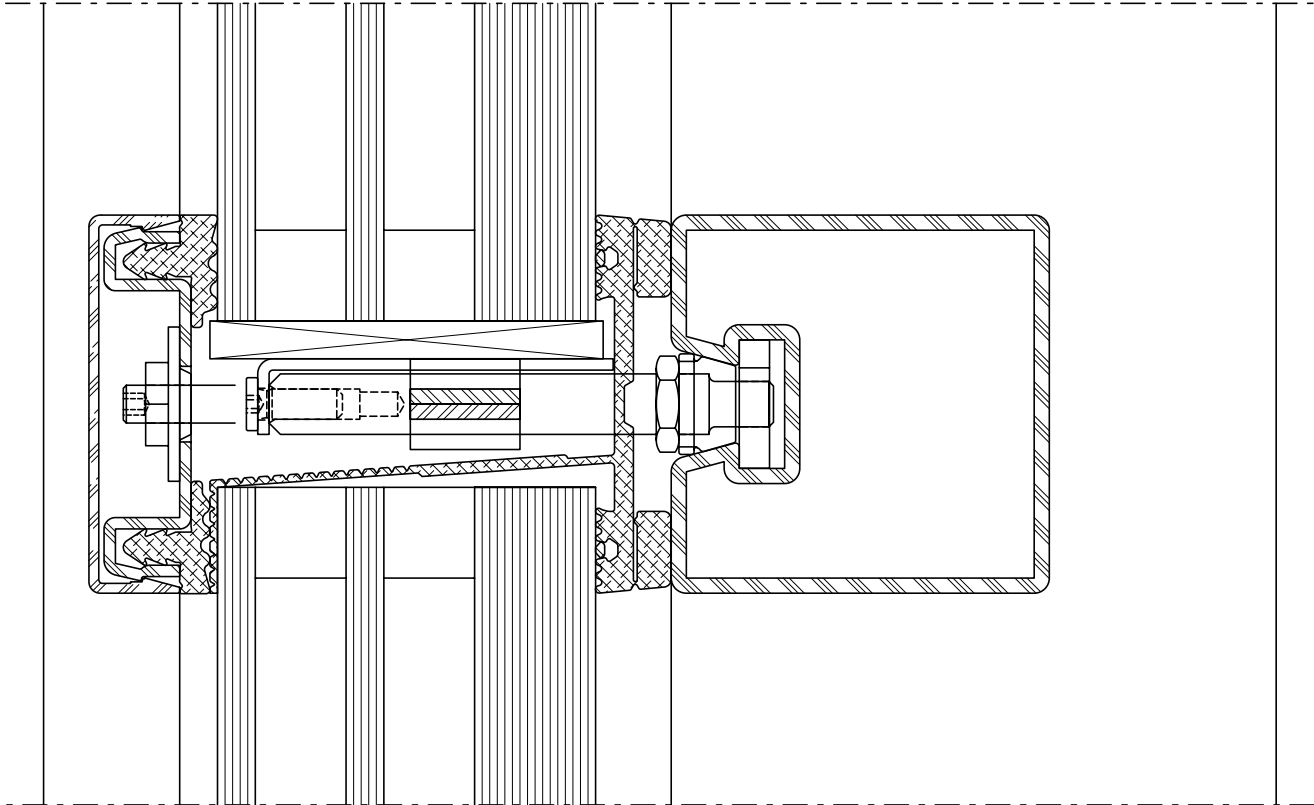

51-0501-C-005

DWG

DXF

Schnittpunkte im Massstab 1:1
Coupe de détails à l'échelle 1:1
Section details on scale 1:1

VISS Fire EI30 Fassade/Trennwand
VISS Fire EI30 façade/cloison
VISS Fire EI30 façade/partition wall

Pfosten-Detail
Ansichtsbreite 50 mm

Détail du montant
Largeur de face 50 mm

Detail of mullion
Width 50 mm

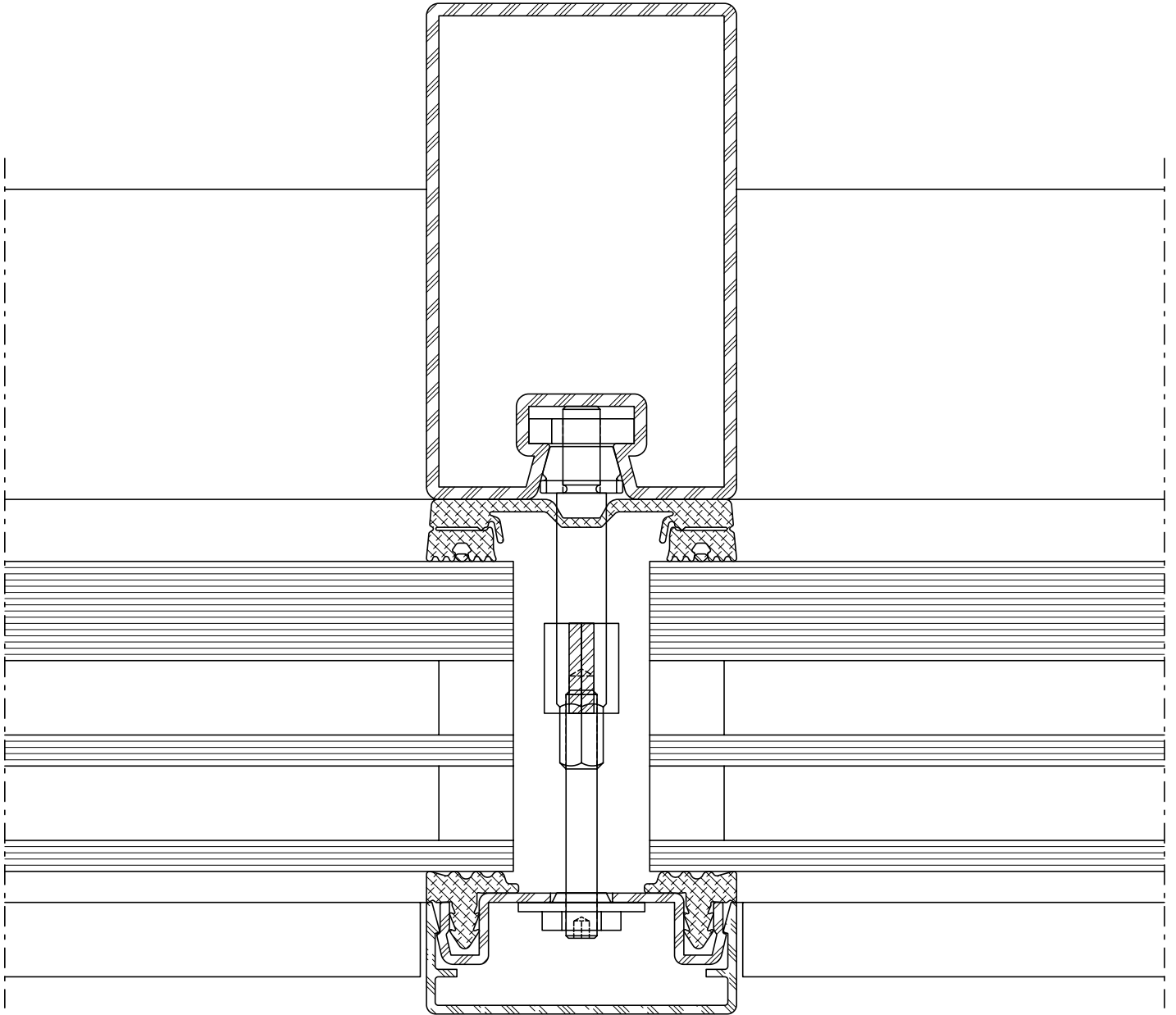

DXF

DWG

51-0501-C-006

Schnittpunkte im Massstab 1:1
Coupe de détails à l'échelle 1:1
Section details on scale 1:1

VISS Fire EI30 Fassade/Trennwand
VISS Fire EI30 façade/cloison
VISS Fire EI30 façade/partition wall

Pfosten-Detail
Ansichtsbreite 50 mm
Trennwandlösung
(nur Innenanwendung)

Détail du montant
Largeur de face 50 mm
Solution de cloison (uniquement
application intérieure)

Detail of mullion
Width 50 mm
Partition wall solution
(internal use only)

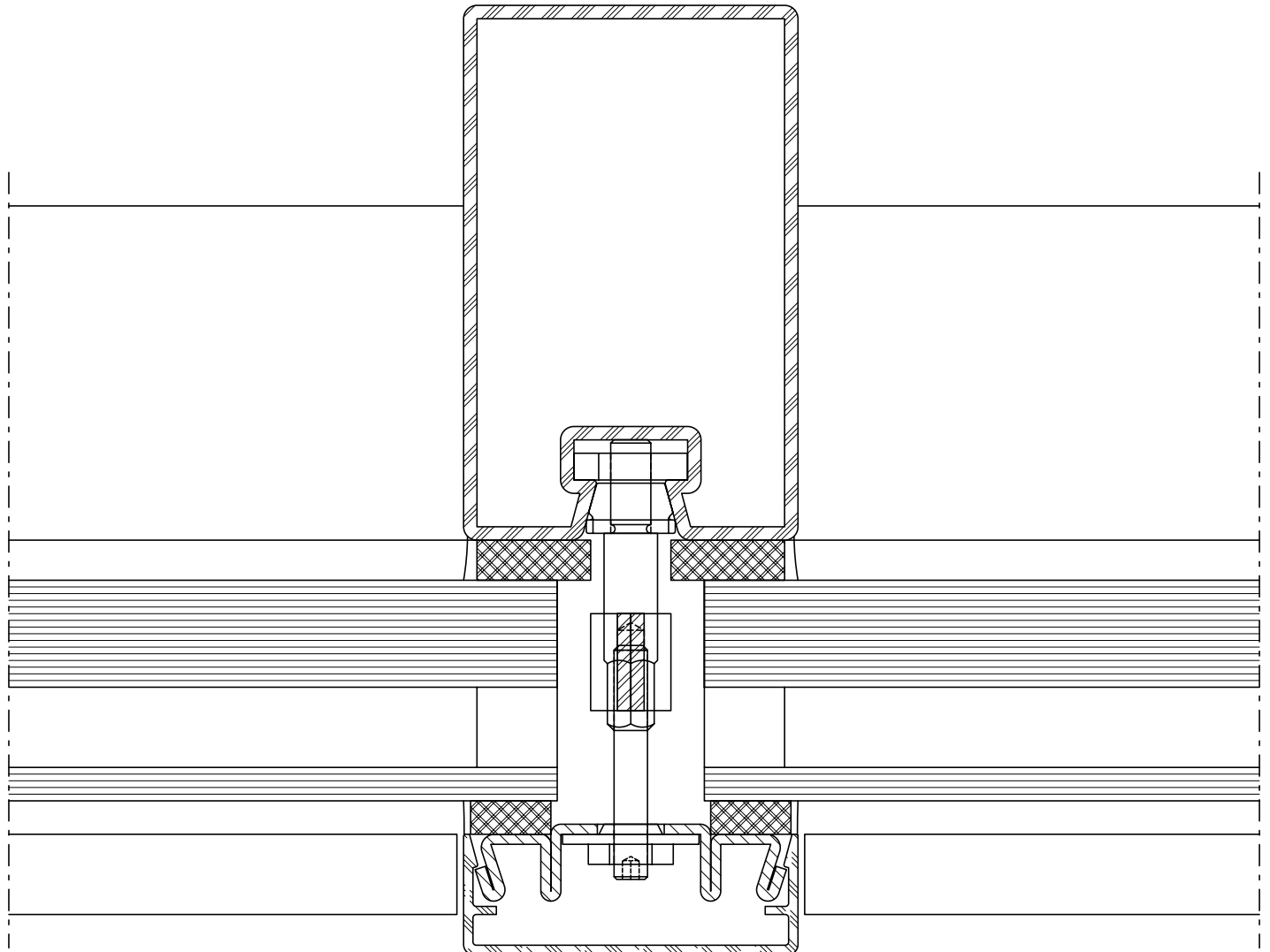

DXF

DWG

51-0503-C-002

Riegel-Detail
Ansichtsbreite 50 mm
Trennwandlösung
(nur Innenanwendung)

Détail de la traverse
Largeur de face 50 mm
Solution de cloison (uniquement
application intérieure)

Detail of transom
Width 50 mm
Partition wall solution
(internal use only)

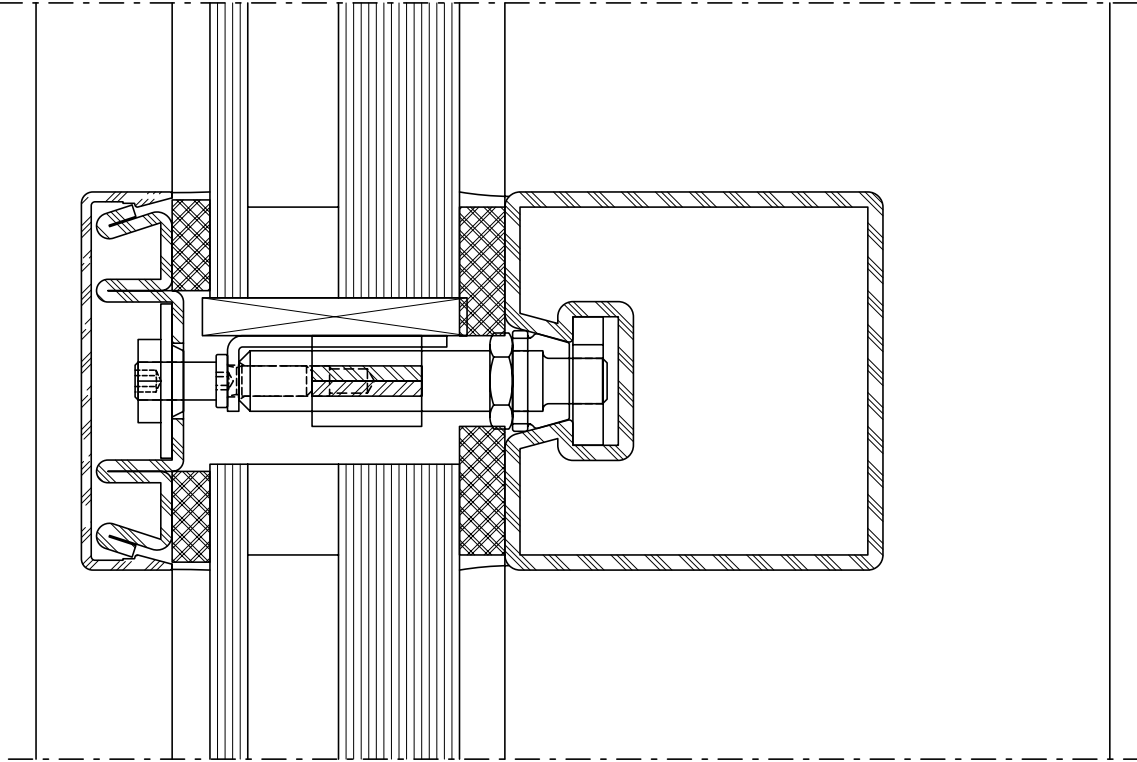

51-0503-C-001

DWG

DXF

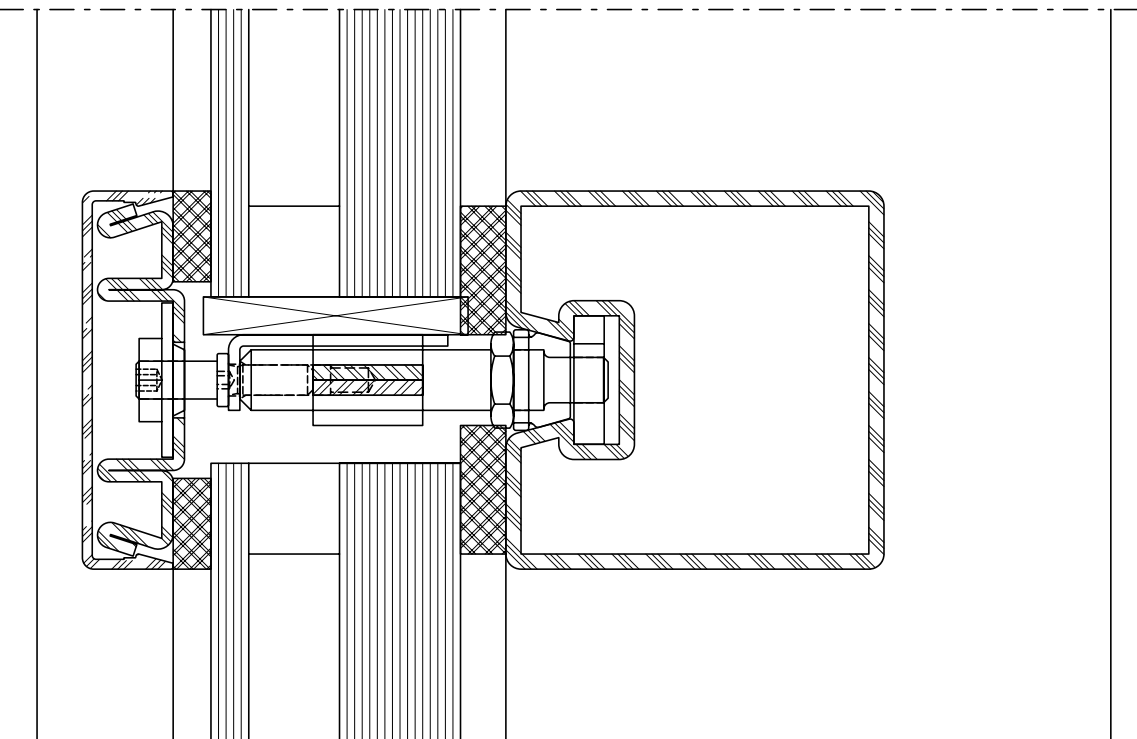

51-0503-C-003

DWG

DXF

Aussenecke 90°

Angle extérieur 90°

Outer corner 90°

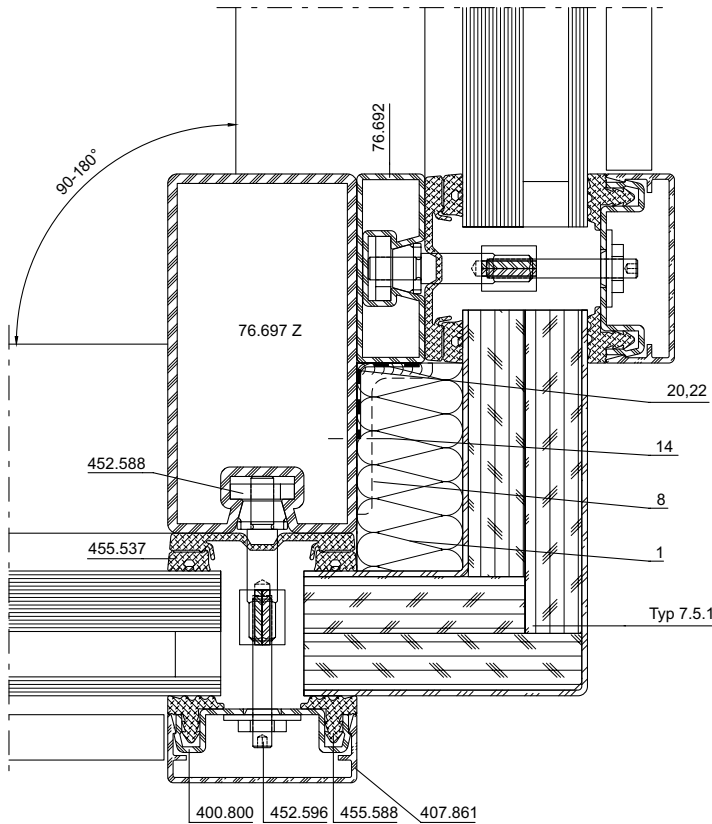

Aufbau:
 1x Brandschutzplatte, $d \geq 15$ mm
 Mineralwolle, $d \geq 40$ mm
Trennwand:
 Brandschutzplatte, $d \geq (20+15)$ mm

Composition:
 1x Plaque coupe-feu, $d \geq 15$ mm
 Laine minérale, $d \geq 40$ mm
Cloison:
 Plaque coupe-feu, $d \geq (20+15)$ mm

Composition:
 1x Fire-resistant panel, $d \geq 15$ mm
 Mineral wool, $d \geq 40$ mm
Partition wall:
 Fire-resistant panel, $d \geq (20+15)$ mm

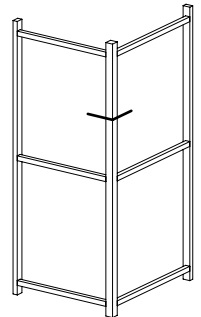

DXF DWG

51-0501-K-017

Aussenecke 90° - 180°

Angle extérieur 90° - 180°

Outer corner 90° - 180°

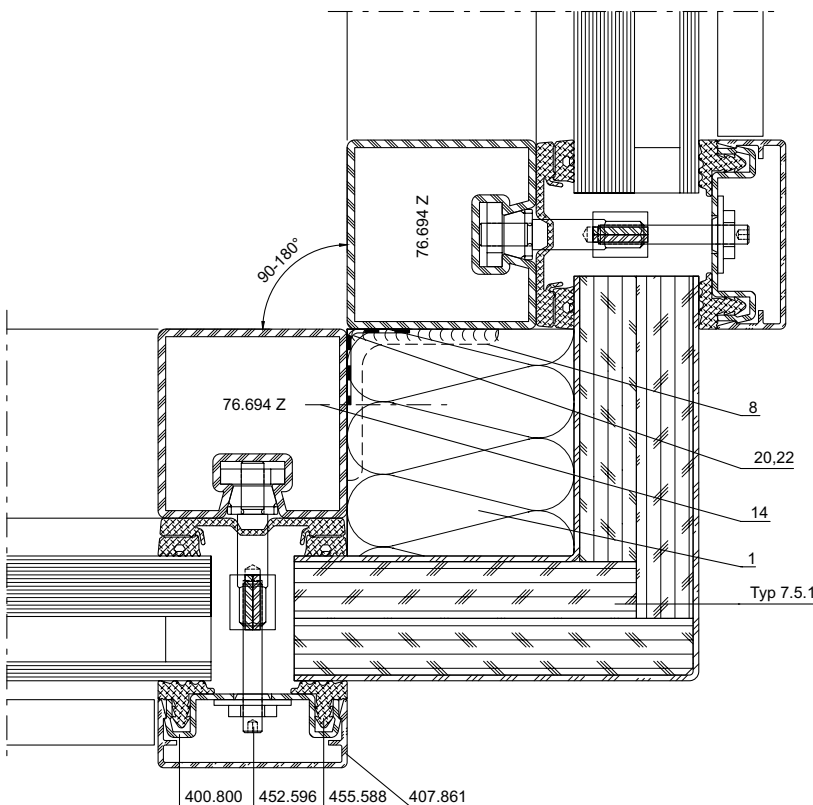

Aufbau:
 1x Brandschutzplatte, $d \geq 15$ mm
 Mineralwolle, $d \geq 40$ mm
Trennwand:
 Brandschutzplatte, $d \geq (20+15)$ mm

Composition:
 1x Plaque coupe-feu, $d \geq 15$ mm
 Laine minérale, $d \geq 40$ mm
Cloison:
 Plaque coupe-feu, $d \geq (20+15)$ mm

Composition:
 1x Fire-resistant panel, $d \geq 15$ mm
 Mineral wool, $d \geq 40$ mm
Partition wall:
 Fire-resistant panel, $d \geq (20+15)$ mm

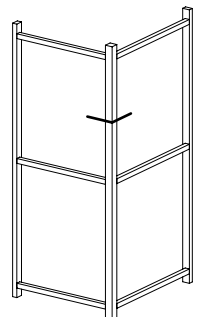

DXF DWG

51-0501-K-018

Aussenecke 90°

Angle extérieur 90°

Outer corner 90°

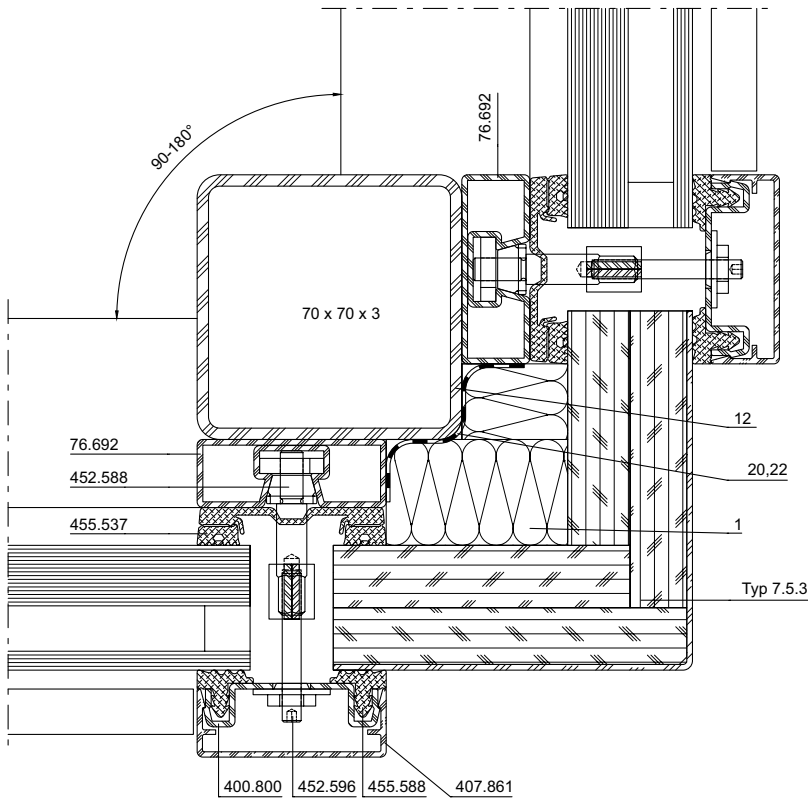

Aufbau:
 1x Brandschutzplatte, $d \geq 15$ mm
 Mineralwolle, $d \geq 40$ mm
Trennwand:
 Brandschutzplatte, $d \geq (20+15)$ mm

Composition:
 1x Plaque coupe-feu, $d \geq 15$ mm
 Laine minérale, $d \geq 40$ mm
Cloison:
 Plaque coupe-feu, $d \geq (20+15)$ mm

Composition:
 1x Fire-resistant panel, $d \geq 15$ mm
 Mineral wool, $d \geq 40$ mm
Partition wall:
 Fire-resistant panel, $d \geq (20+15)$ mm

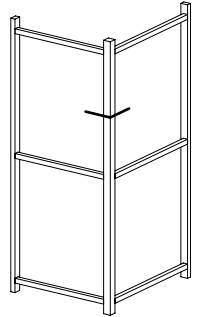

DXF DWG

51-0501-K-019

Aussenecke 90° - 180°

Angle extérieur 90° - 180°

Outer corner 90° - 180°

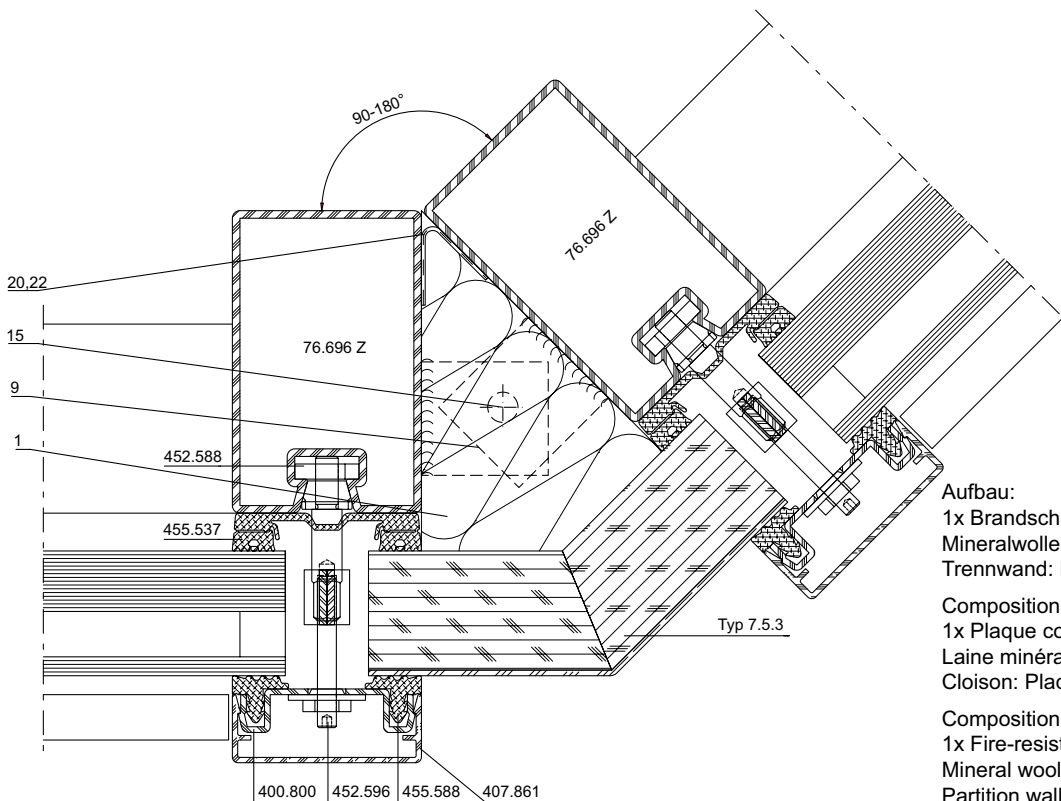

Aufbau:
 1x Brandschutzplatte, $d \geq 15$ mm
 Mineralwolle, $d \geq 40$ mm
Trennwand: Brandschutzplatte, $d \geq (20+15)$ mm

Composition:
 1x Plaque coupe-feu, $d \geq 15$ mm
 Laine minérale, $d \geq 40$ mm
Cloison: Plaque coupe-feu, $d \geq (20+15)$ mm

Composition:
 1x Fire-resistant panel, $d \geq 15$ mm
 Mineral wool, $d \geq 40$ mm
Partition wall: Fire-resistant panel, $d \geq (20+15)$ mm

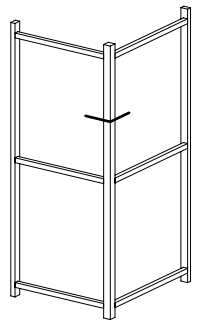

DXF DWG

51-0501-K-020

Aussenecke 90° - 180°

Angle extérieur 90° - 180°

Outer corner 90° - 180°

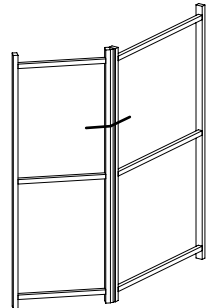
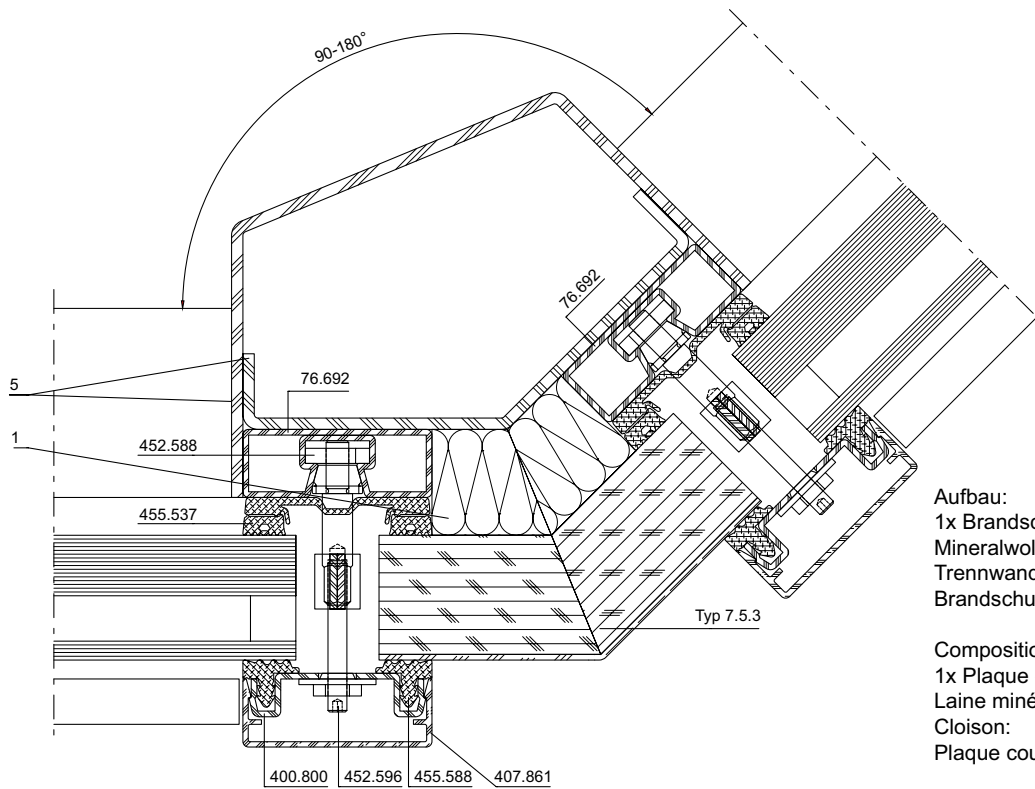

DXF DWG

51-0501-K-021

Aufbau:
1x Brandschutzplatte, $d \geq 15$ mm
Mineralwolle, $d \geq 40$ mm
Trennwand:
Brandschutzplatte, $d \geq (20+15)$ mm

Composition:
1x Plaque coupe-feu, $d \geq 15$ mm
Laine minérale, $d \geq 40$ mm
Cloison:
Plaque coupe-feu, $d \geq (20+15)$ mm

Composition:
1x Fire-resistant panel, $d \geq 15$ mm
Mineral wool, $d \geq 40$ mm
Partition wall:
Fire-resistant panel, $d \geq (20+15)$ mm

Innenecke 90° - 180°

Angle intérieur 90° - 180°

Inner corner 90° - 180°

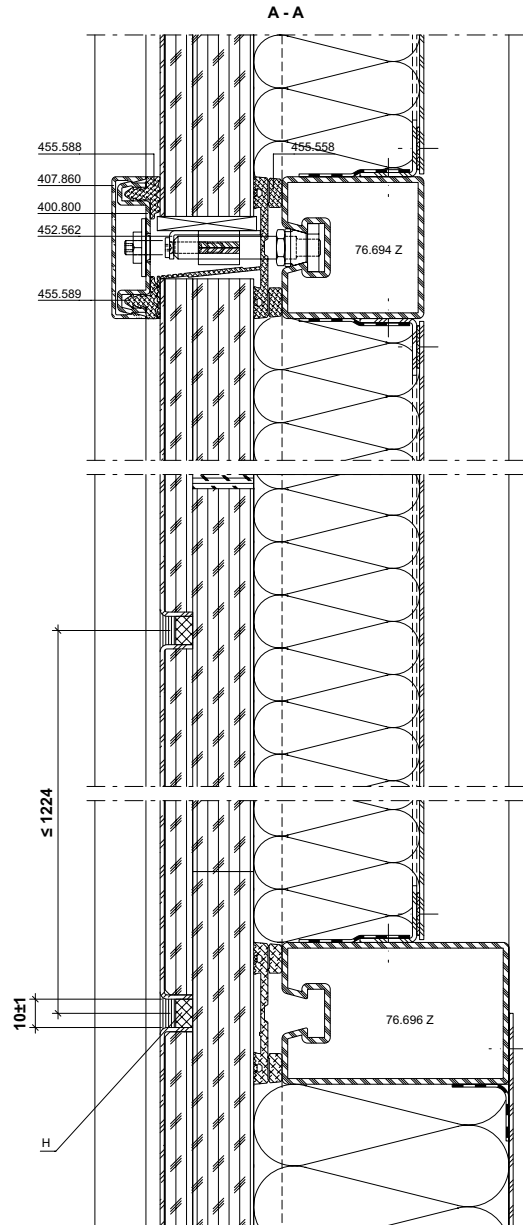
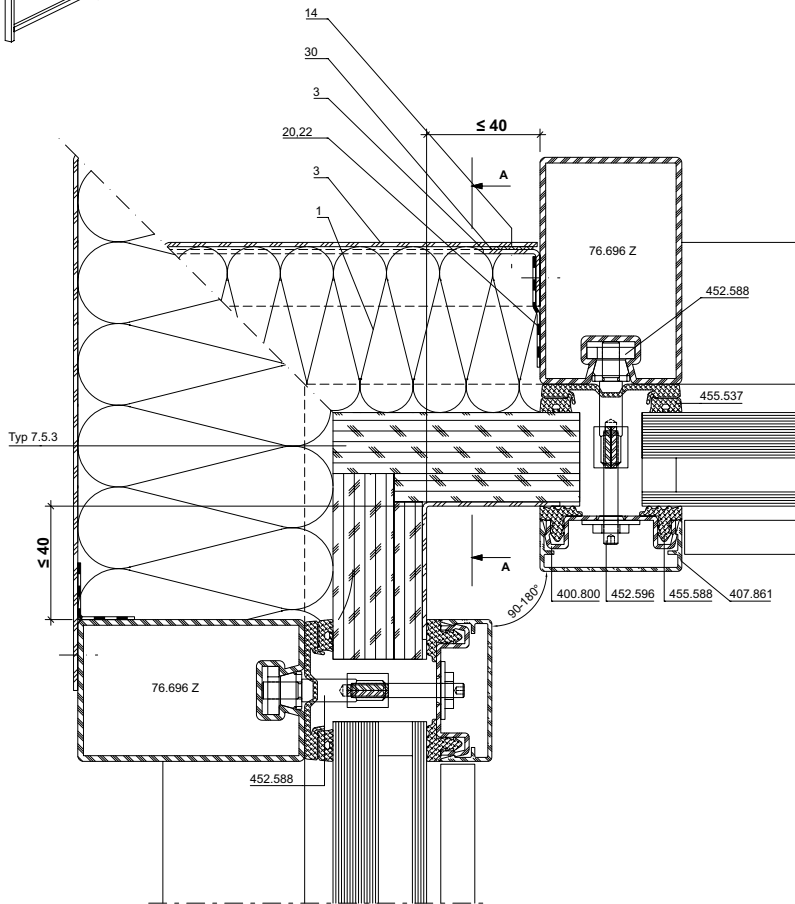
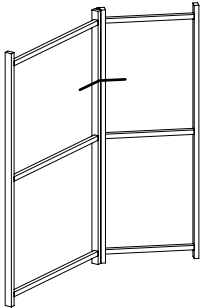

- Aufbau:**
 1x Brandschutzplatte, $d \geq 15$ mm
 Mineralwolle, $d \geq 40$ mm
Trennwand:
 Brandschutzplatte, $d \geq (20+15)$ mm
- Composition:**
 1x Plaque coupe-feu, $d \geq 15$ mm
 Laine minérale, $d \geq 40$ mm
Cloison:
 Plaque coupe-feu, $d \geq (20+15)$ mm
- Composition:**
 1x Fire-resistant panel, $d \geq 15$ mm
 Mineral wool, $d \geq 40$ mm
Partition wall:
 Fire-resistant panel, $d \geq (20+15)$ mm

DXF DWG

51-0501-K-008

Innenecke 90° - 180°

Angle intérieur 90° - 180°

Inner corner 90° - 180°

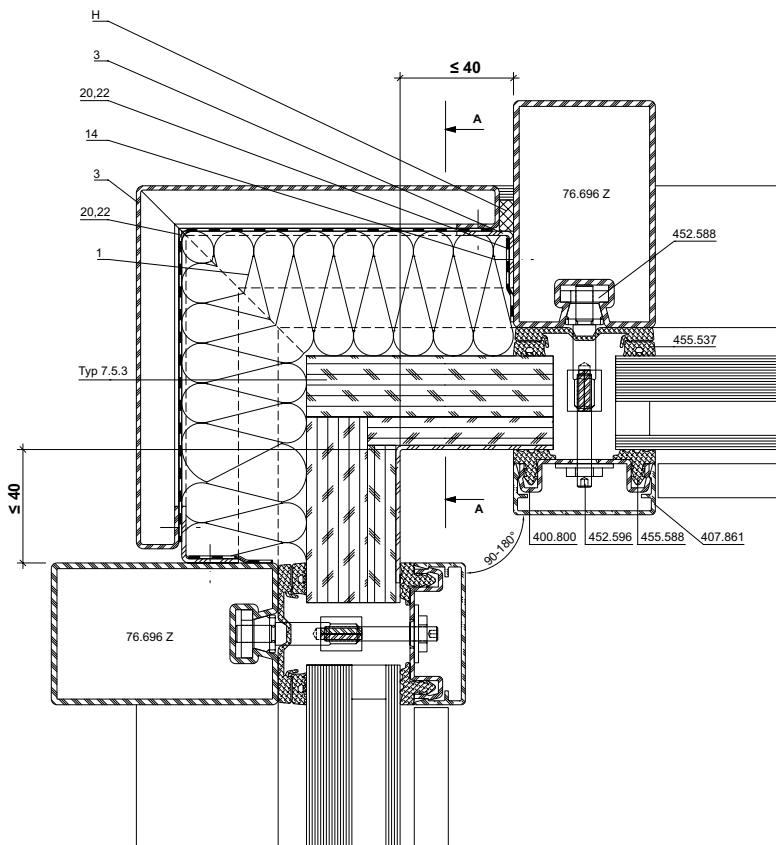
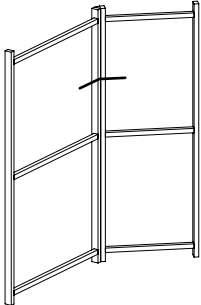

- Aufbau:**
 1x Brandschutzplatte, $d \geq 15$ mm
 Mineralwolle, $d \geq 40$ mm
Trennwand:
 Brandschutzplatte, $d \geq (20+15)$ mm
- Composition:**
 1x Plaque coupe-feu, $d \geq 15$ mm
 Laine minérale, $d \geq 40$ mm
Cloison:
 Plaque coupe-feu, $d \geq (20+15)$ mm
- Composition:**
 1x Fire-resistant panel, $d \geq 15$ mm
 Mineral wool, $d \geq 40$ mm
Partition wall:
 Fire-resistant panel, $d \geq (20+15)$ mm

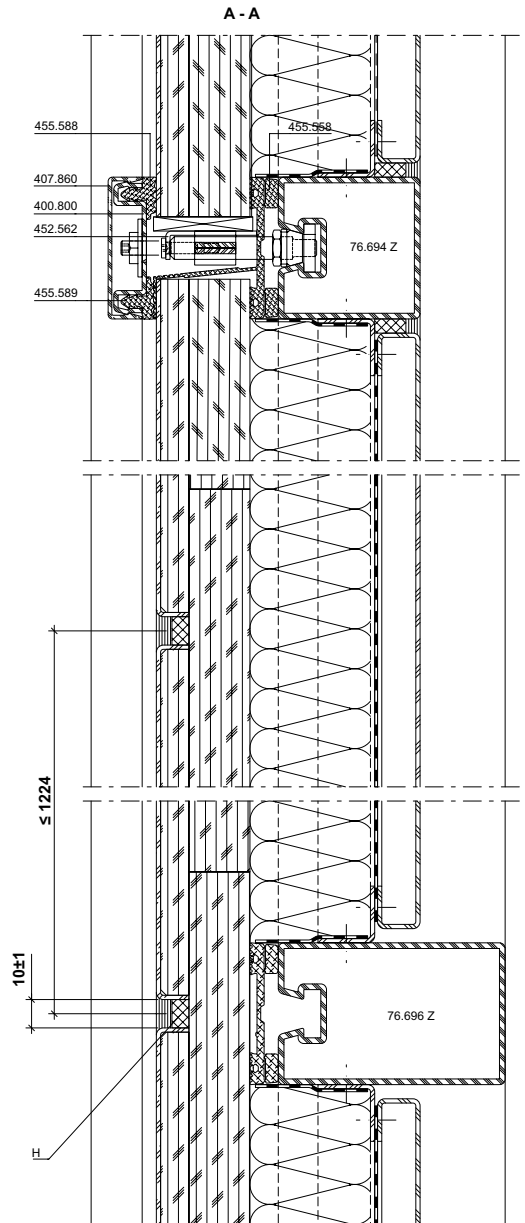

DXF **DWG**

51-0501-K-009

Innenecke 90°-180°

Angle intérieur 90°-180°

Inner corner 90°-180°

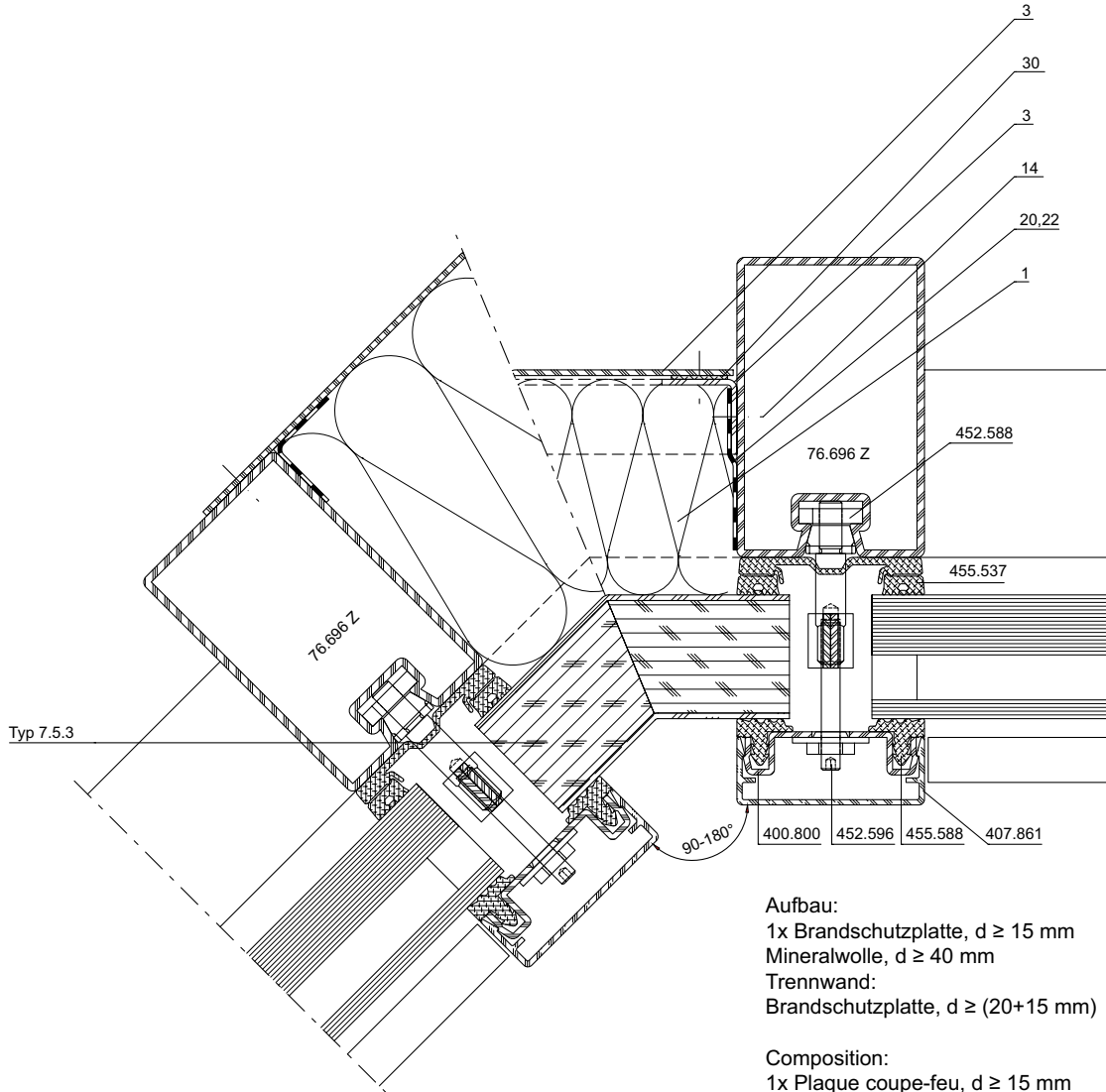

DXF DWG

51-0501-K-012

Aufbau:
 1x Brandschutzplatte, $d \geq 15$ mm
 Mineralwolle, $d \geq 40$ mm
 Trennwand:
 Brandschutzplatte, $d \geq (20+15)$ mm

Composition:
 1x Plaque coupe-feu, $d \geq 15$ mm
 Laine minérale, $d \geq 40$ mm
 Cloison:
 Plaque coupe-feu, $d \geq (20+15)$ mm

Composition:
 1x Fire-resistant panel, $d \geq 15$ mm
 Mineral wool, $d \geq 40$ mm
 Partition wall:
 Fire-resistant panel, $d \geq (20+15)$ mm

Innenecke 90°-180°

Angle intérieur 90°-180°

Inner corner 90°-180°

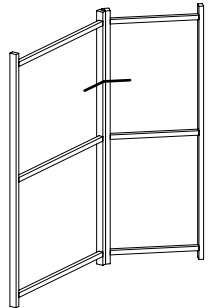
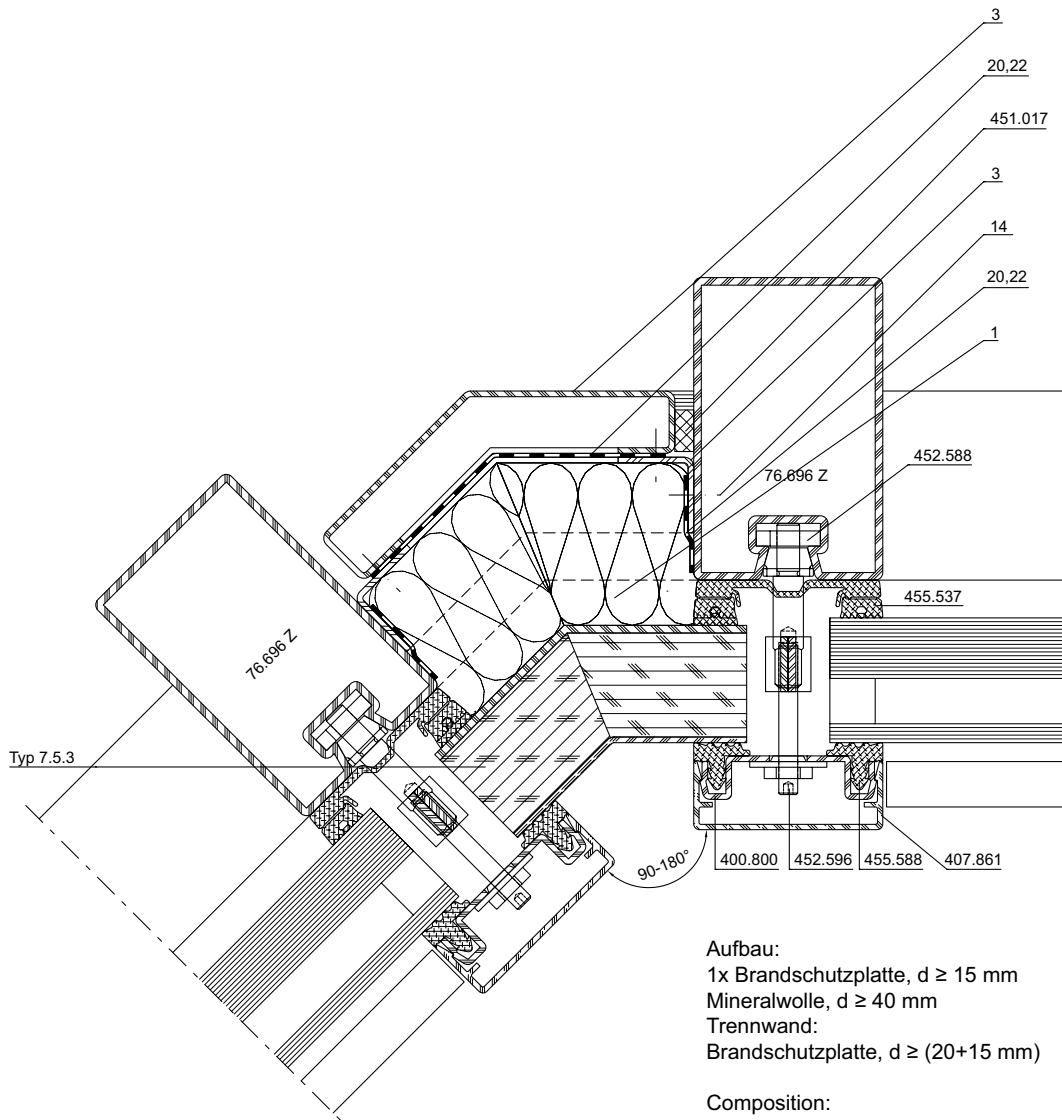

DXF DWG

51-0501-K-013

Aufbau:
 1x Brandschutzplatte, $d \geq 15$ mm
 Mineralwolle, $d \geq 40$ mm
 Trennwand:
 Brandschutzplatte, $d \geq (20+15)$ mm)

Composition:
 1x Plaque coupe-feu, $d \geq 15$ mm
 Laine minérale, $d \geq 40$ mm
 Cloison:
 Plaque coupe-feu, $d \geq (20+15)$ mm)

Composition:
 1x Fire-resistant panel, $d \geq 15$ mm
 Mineral wool, $d \geq 40$ mm
 Partition wall:
 Fire-resistant panel, $d \geq (20+15)$ mm)

Innenecke 90°-180°

Angle intérieur 90°-180°

Inner corner 90°-180°

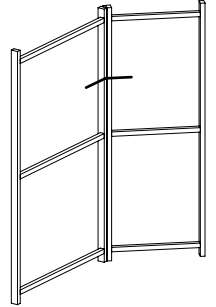
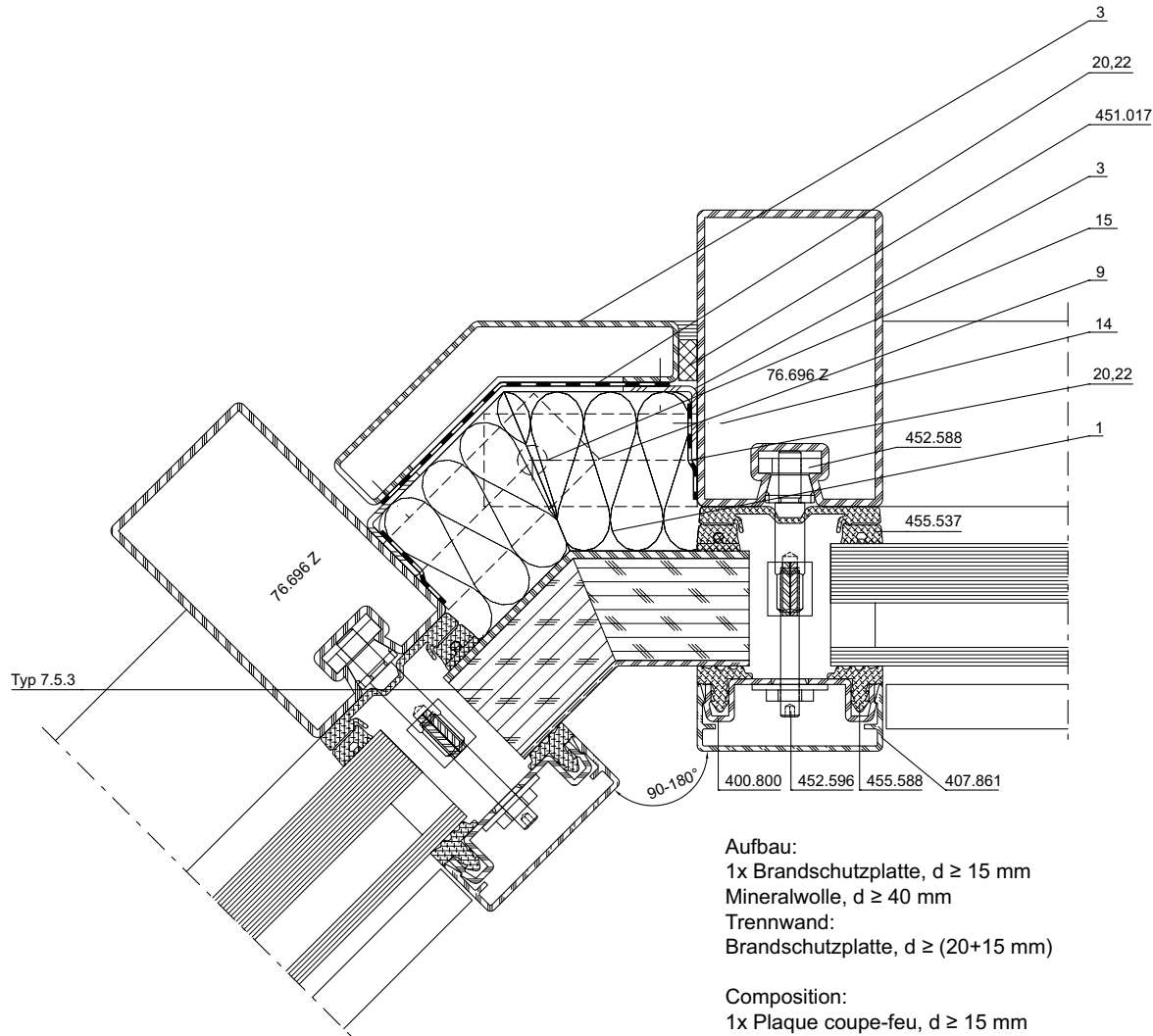

DXF DWG

51-0501-K-014

Aufbau:
 1x Brandschutzplatte, $d \geq 15$ mm
 Mineralwolle, $d \geq 40$ mm
 Trennwand:
 Brandschutzplatte, $d \geq (20+15$ mm)

Composition:
 1x Plaque coupe-feu, $d \geq 15$ mm
 Laine minérale, $d \geq 40$ mm
 Cloison:
 Plaque coupe-feu, $d \geq (20+15$ mm)

Composition:
 1x Fire-resistant panel, $d \geq 15$ mm
 Mineral wool, $d \geq 40$ mm
 Partition wall:
 Fire-resistant panel, $d \geq (20+15$ mm)

Bodenanschluss

Fixation au sol

Floor attachment

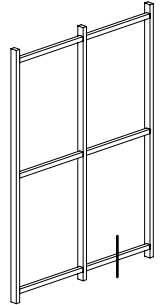
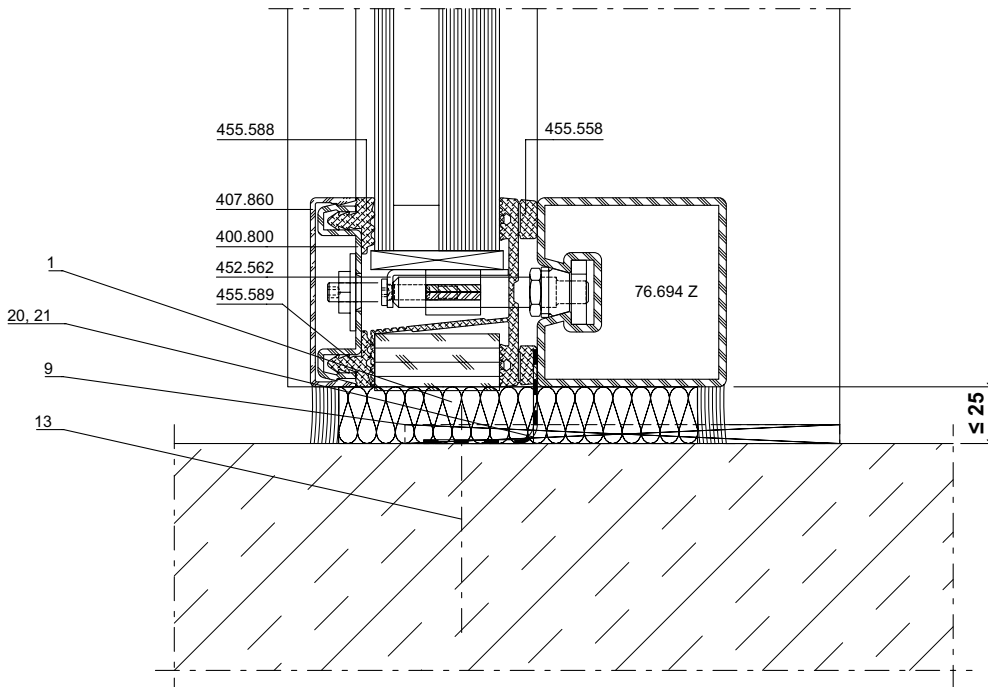

DXF DWG

51-0501-A-001

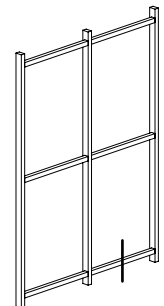
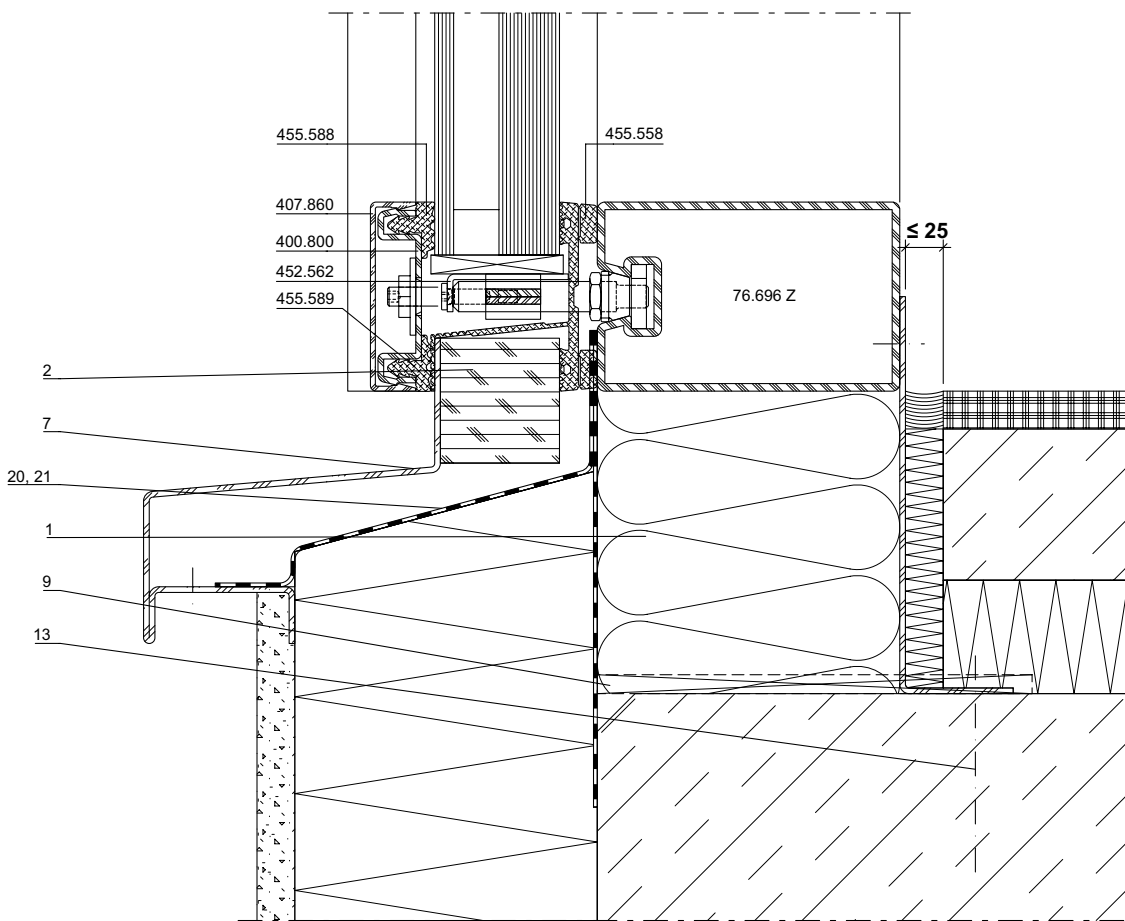

DXF DWG

51-0501-A-002

Bodenanschluss

Fixation au sol

Floor attachment

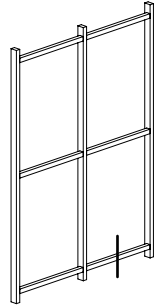
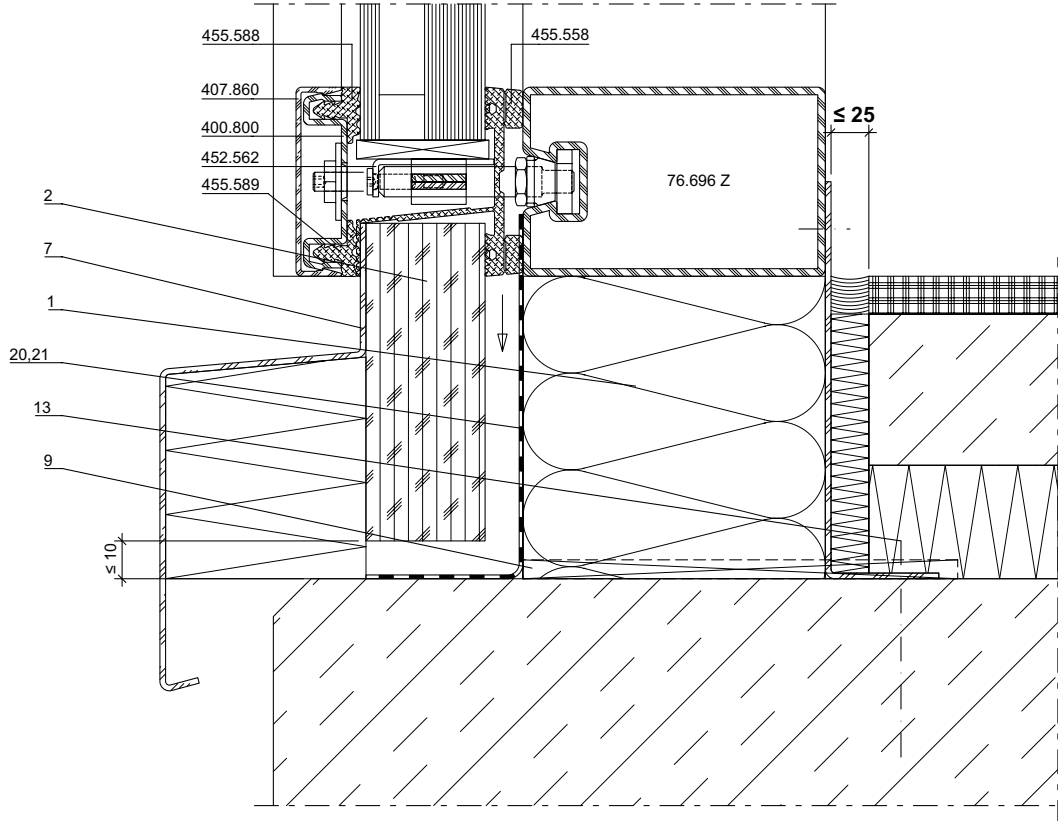

DXF **DWG**

51-0501-A-003

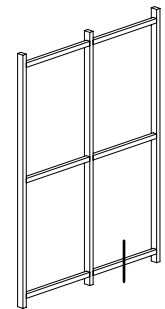
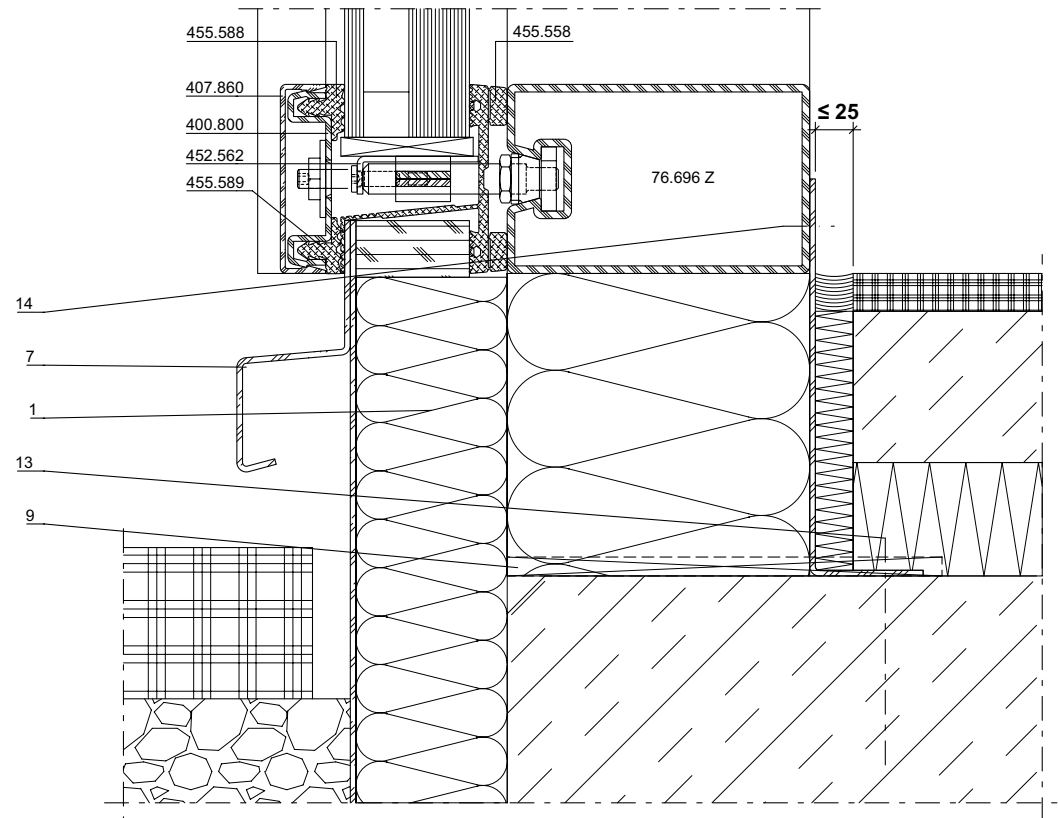

DXF **DWG**

51-0501-A-004

Anschlüsse am Bau im Massstab 1:2
Raccords au mur à l'échelle 1:2
Attachment to structure on scale 1:2

VISS Fire EI30 Fassade/Trennwand
VISS Fire EI30 façade/cloison
VISS Fire EI30 façade/partition wall

Bodenanschluss

Fixation au sol

Floor attachment

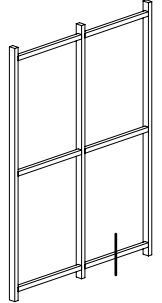
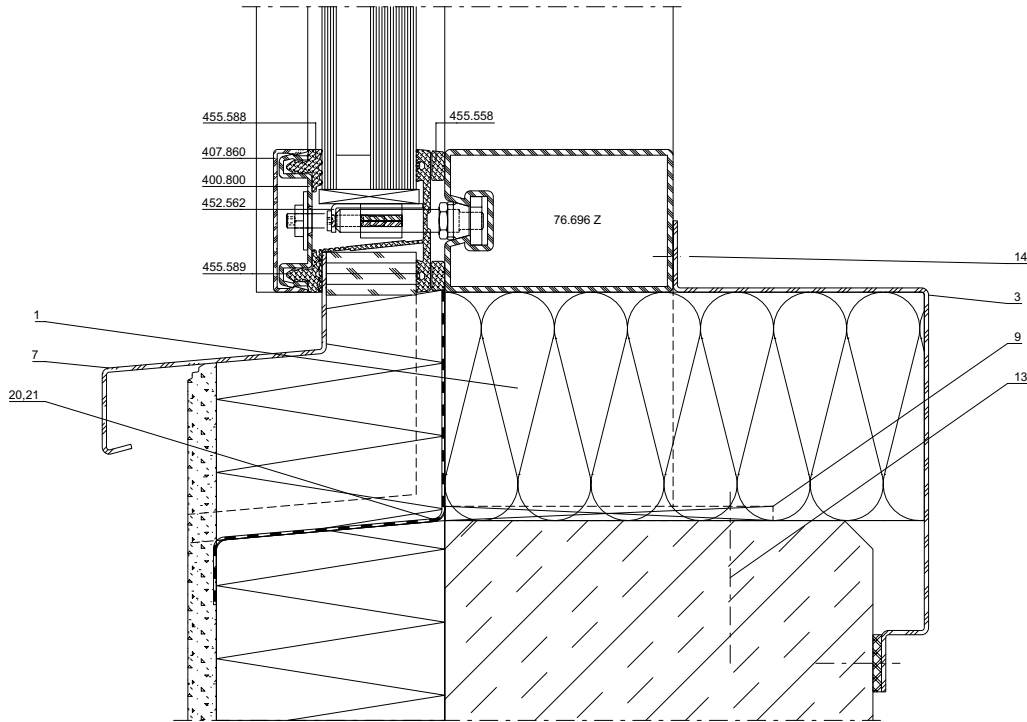

DXF DWG

51-0501A-005

Anschlüsse am Bau im Massstab 1:2
Raccords au mur à l'échelle 1:2
Attachment to structure on scale 1:2

VISS Fire EI30 Fassade/Trennwand
VISS Fire EI30 façade/cloison
VISS Fire EI30 façade/partition wall

Bodenanschluss

Fixation au sol

Floor attachment

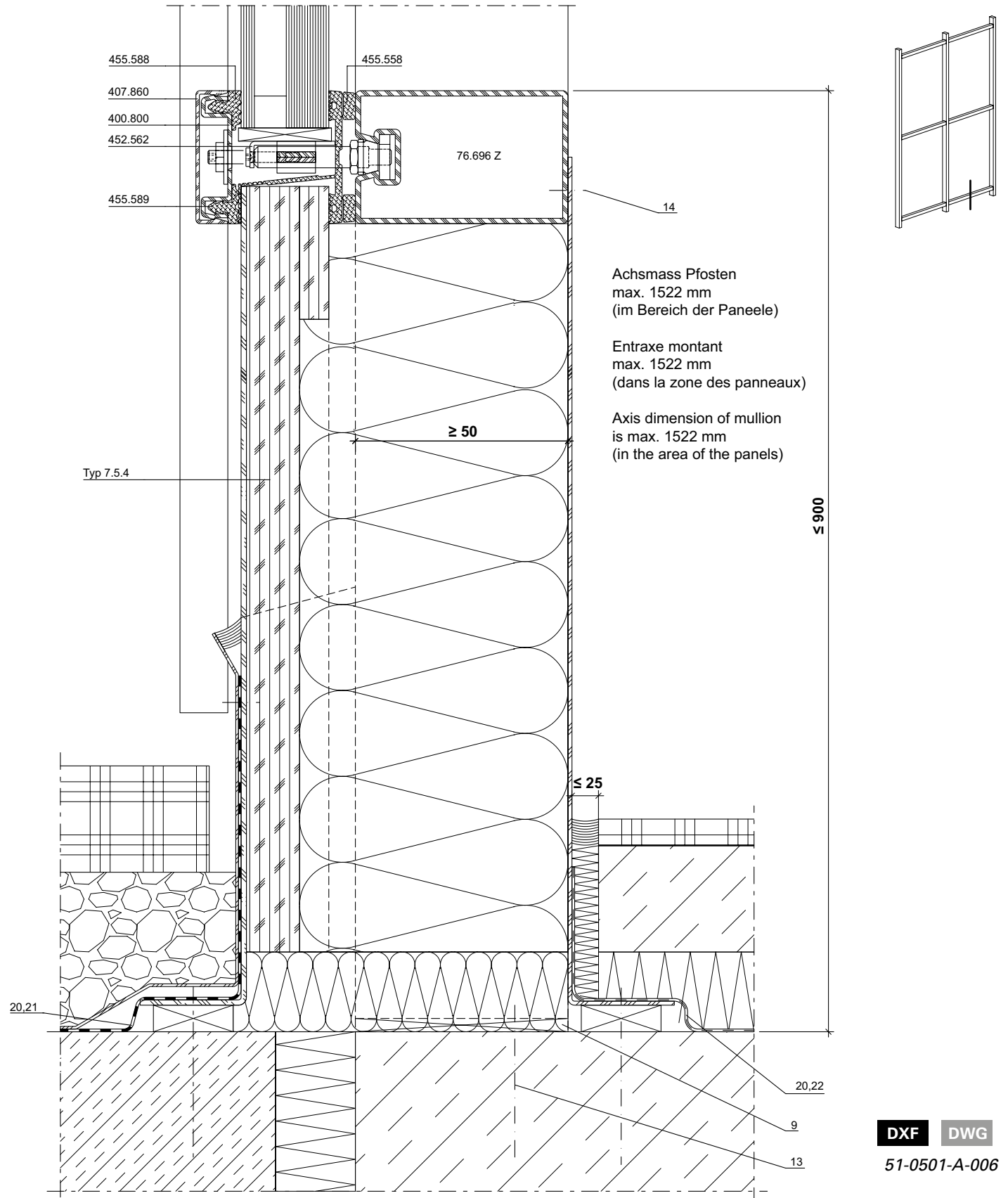

Bodenanschluss

Fixation au sol

Floor attachment

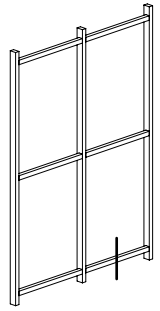
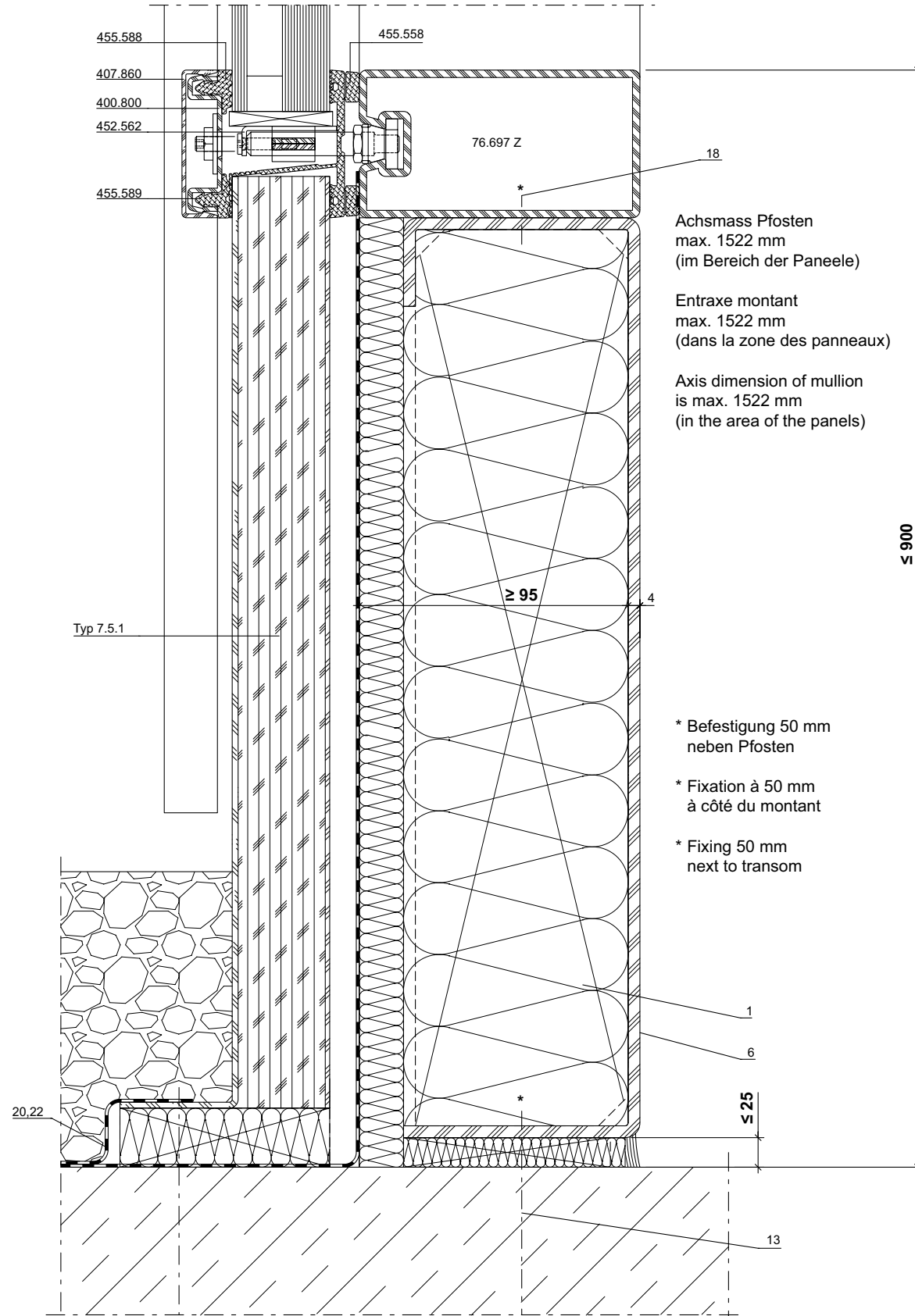

Achsmass Pfosten
 max. 1522 mm
 (im Bereich der Paneele)

Entraxe montant
 max. 1522 mm
 (dans la zone des panneaux)

Axis dimension of mullion
 is max. 1522 mm
 (in the area of the panels)

* Befestigung 50 mm
 neben Pfosten

* Fixation à 50 mm
 à côté du montant

* Fixing 50 mm
 next to transom

DXF DWG

51-0501-A-007

Anschlüsse am Bau im Massstab 1:2

Raccords au mur à l'échelle 1:2

Attachment to structure on scale 1:2

VISS Fire EI30 Fassade/Trennwand

VISS Fire EI30 façade/cloison

VISS Fire EI30 façade/partition wall

Bodenanschluss

Fixation au sol

Floor attachment

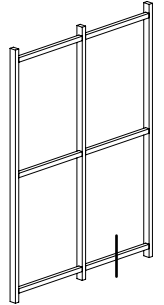
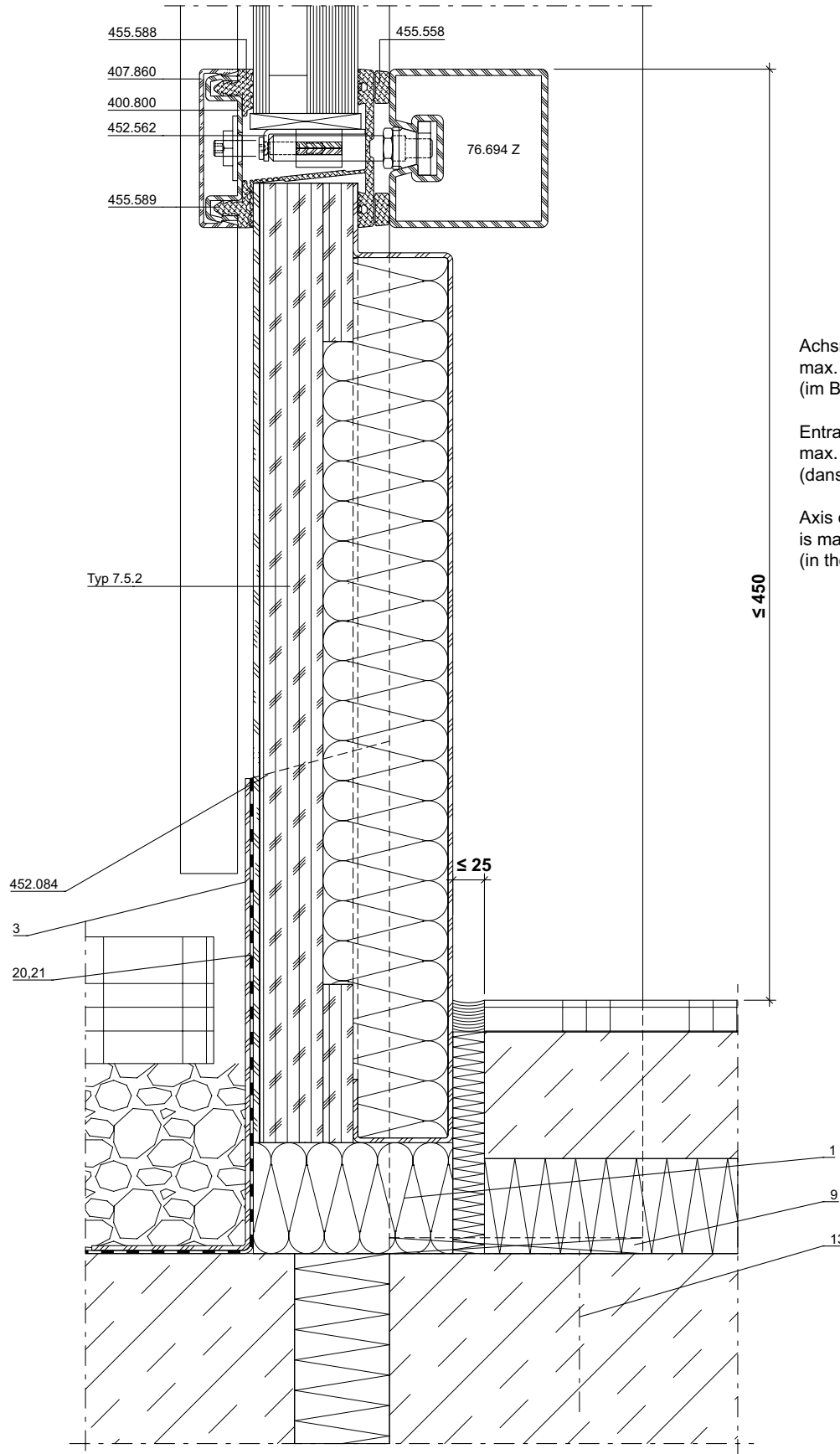

Achsmass Pfosten
max. 1522 mm
(im Bereich der Paneele)

Entraxe montant
max. 1522 mm
(dans la zone des panneaux)

Axis dimension of mullion
is max. 1522 mm
(in the area of the panels)

DXF DWG

51-0501-A-008

Bodenanschluss

Fixation au sol

Floor attachment

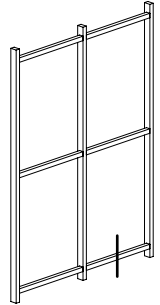
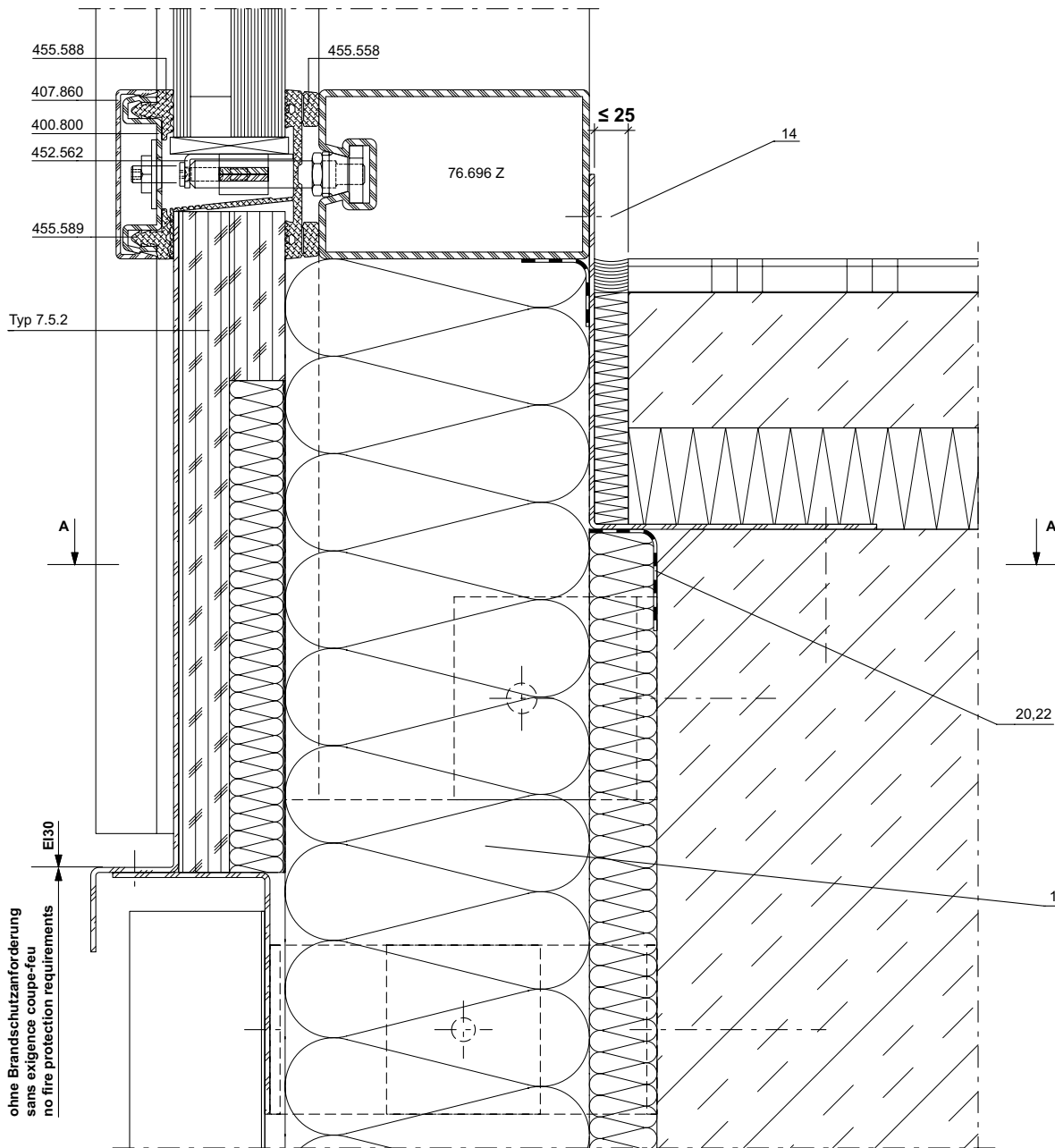

ohne Brandschutzanforderung
 sans exigence coupe-feu
 no fire protection requirements

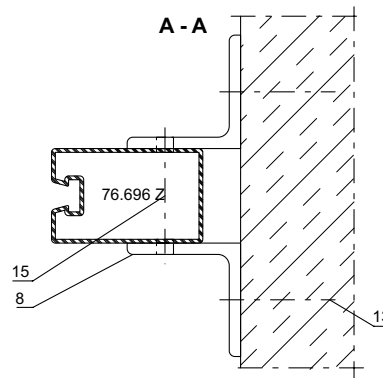

DXF DWG

51-0501-A-009

Anschlüsse am Bau im Massstab 1:2
Raccords au mur à l'échelle 1:2
Attachment to structure on scale 1:2

VISS Fire EI30 Fassade/Trennwand
VISS Fire EI30 façade/cloison
VISS Fire EI30 façade/partition wall

Bodenanschluss

Fixation au sol

Floor attachment

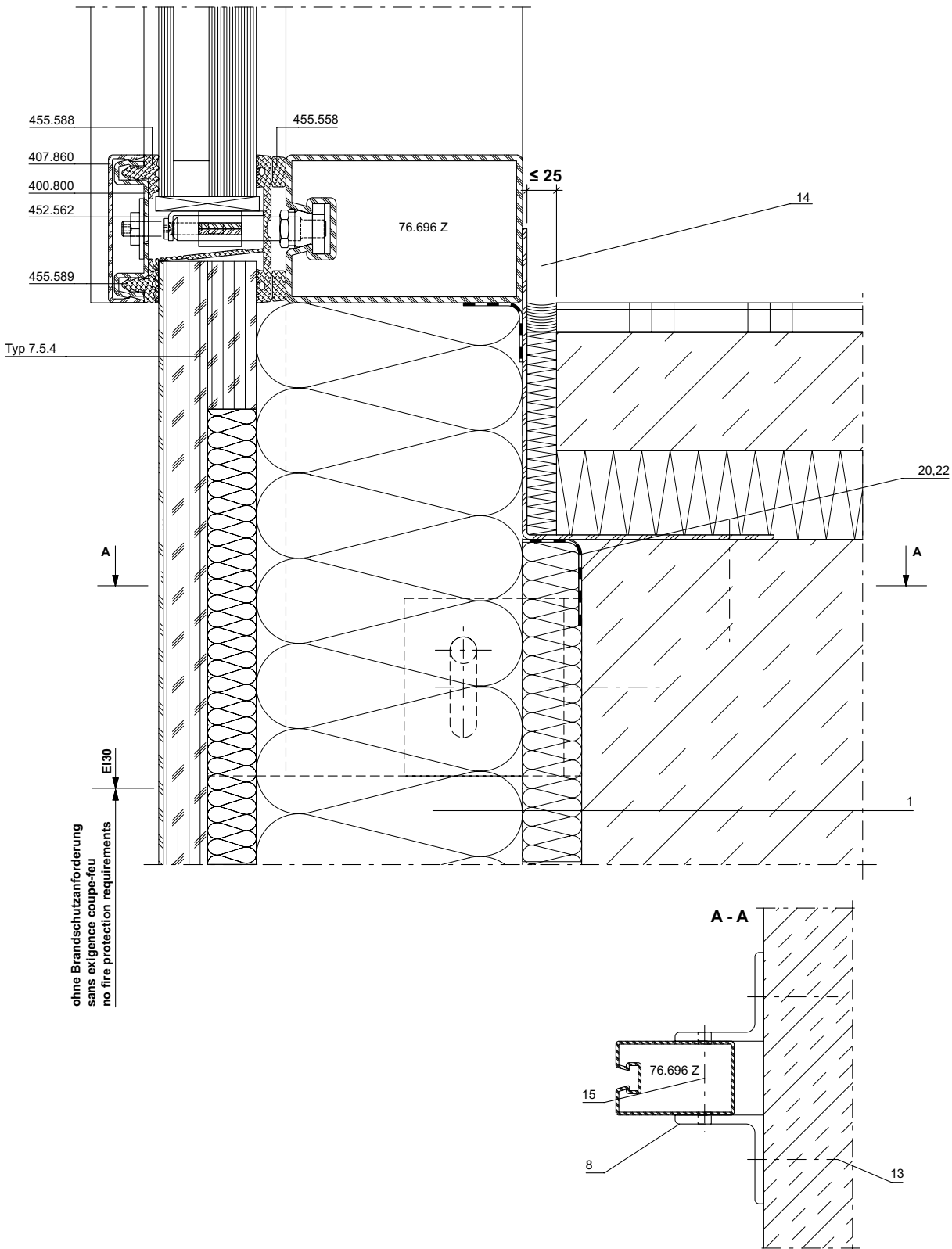

DXF DWG

51-0501-A-010

Deckenanschluss

Fixation au plafond

Intermediate floor attachment

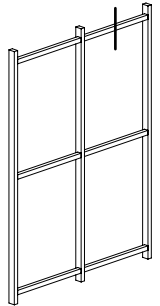
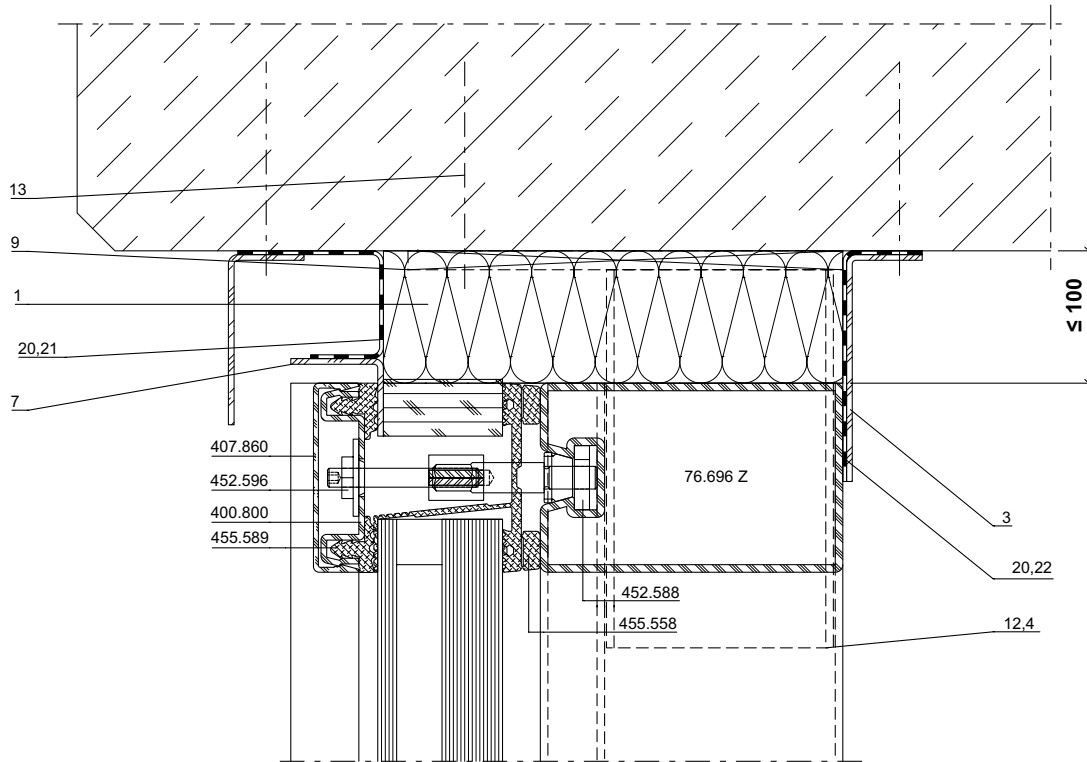

DXF DWG

51-0501-A-011

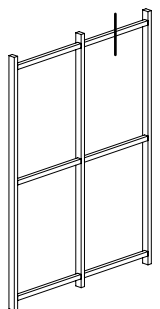
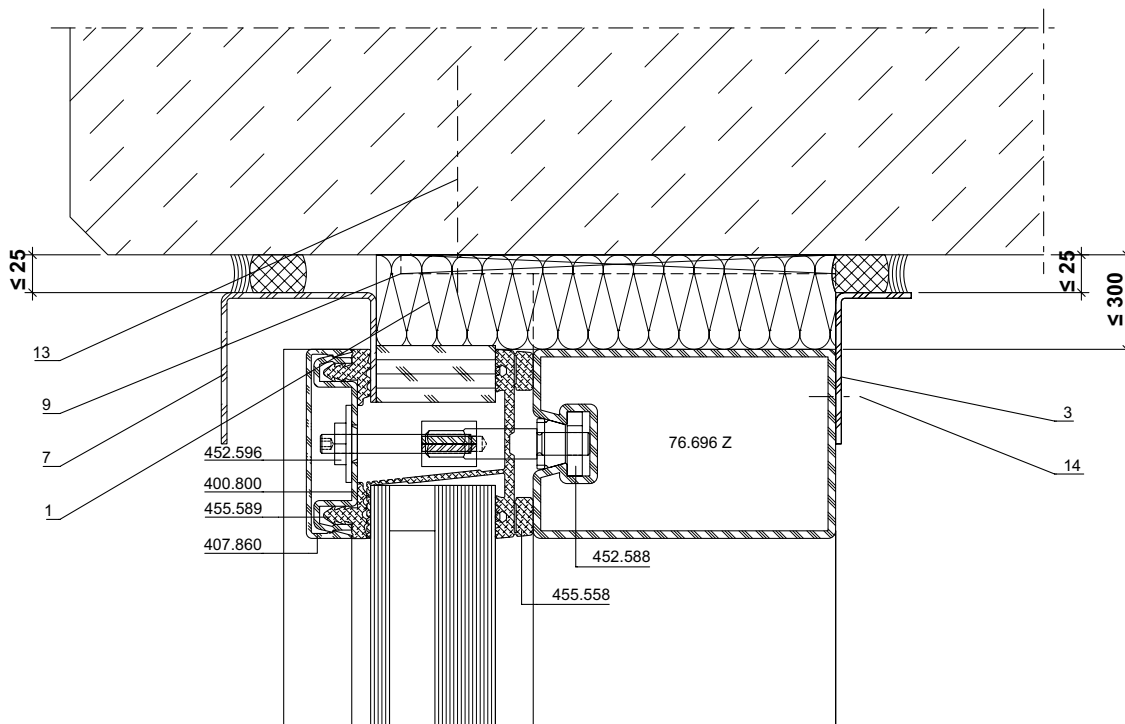

DXF DWG

51-0501-A-012

Anschlüsse am Bau im Massstab 1:2
Raccords au mur à l'échelle 1:2
Attachment to structure on scale 1:2

VISS Fire EI30 Fassade/Trennwand
VISS Fire EI30 façade/cloison
VISS Fire EI30 façade/partition wall

Deckenanschluss

Fixation au plafond

Intermediate floor attachment

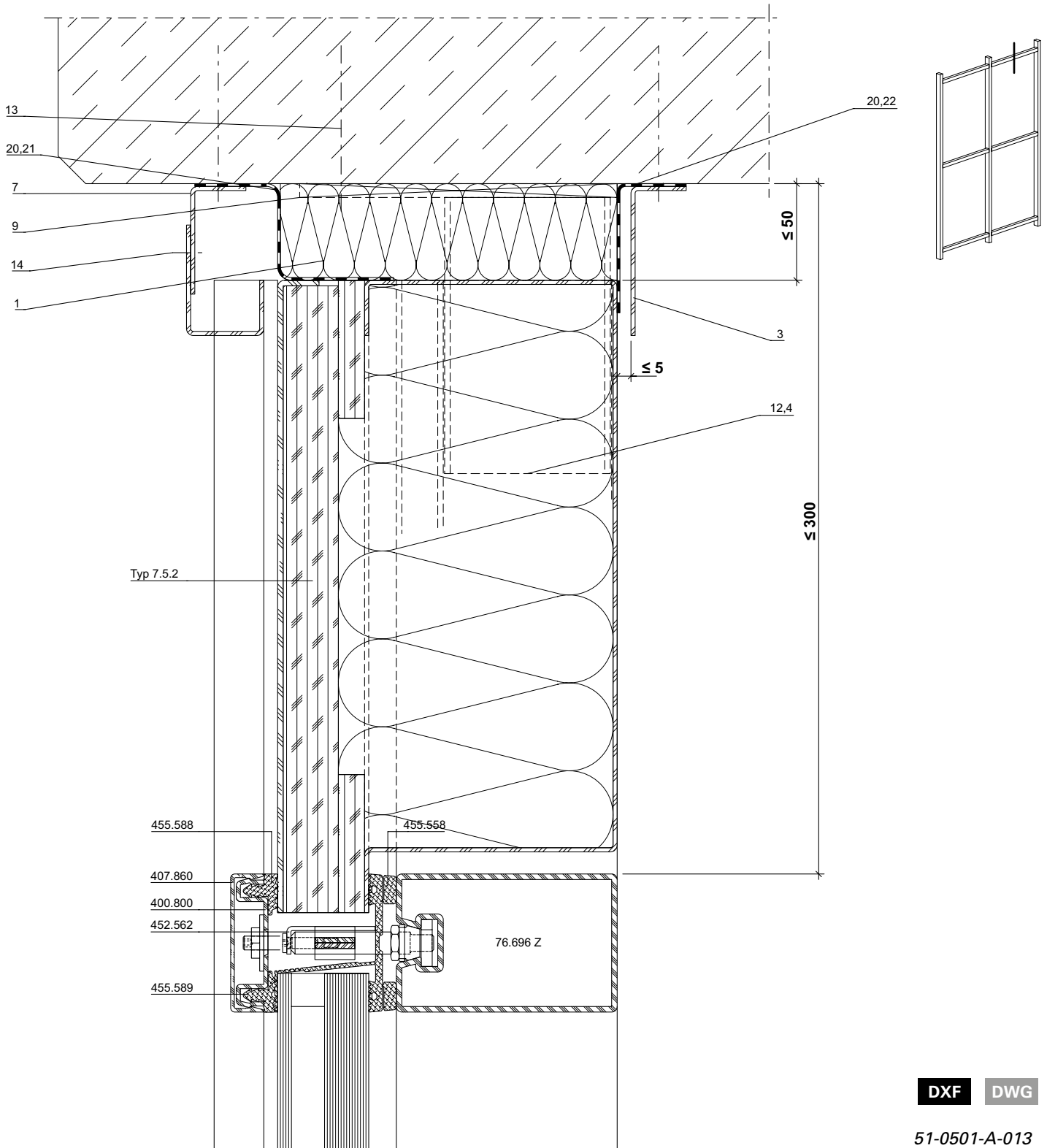

DXF **DWG**

51-0501-A-013

Anschlüsse am Bau im Masstab 1:2
Raccords au mur à l'échelle 1:2
Attachment to structure on scale 1:2

VISS Fire EI30 Fassade/Trennwand
VISS Fire EI30 façade/cloison
VISS Fire EI30 façade/partition wall

Deckenanschluss

Fixation au plafond

Intermediate floor attachment

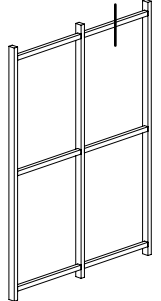
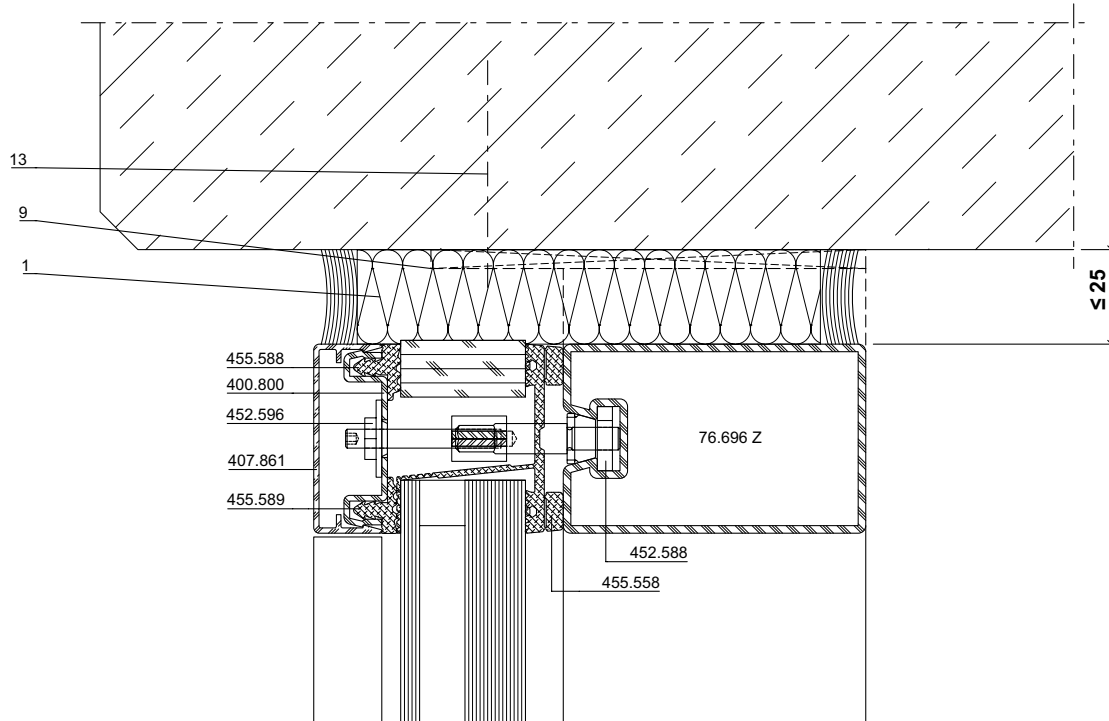

DXF DWG

51-0501-A-014

Deckenanschluss

Fixation au plafond

Intermediate floor attachment

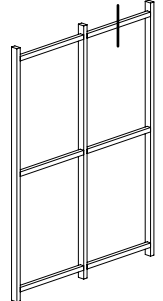
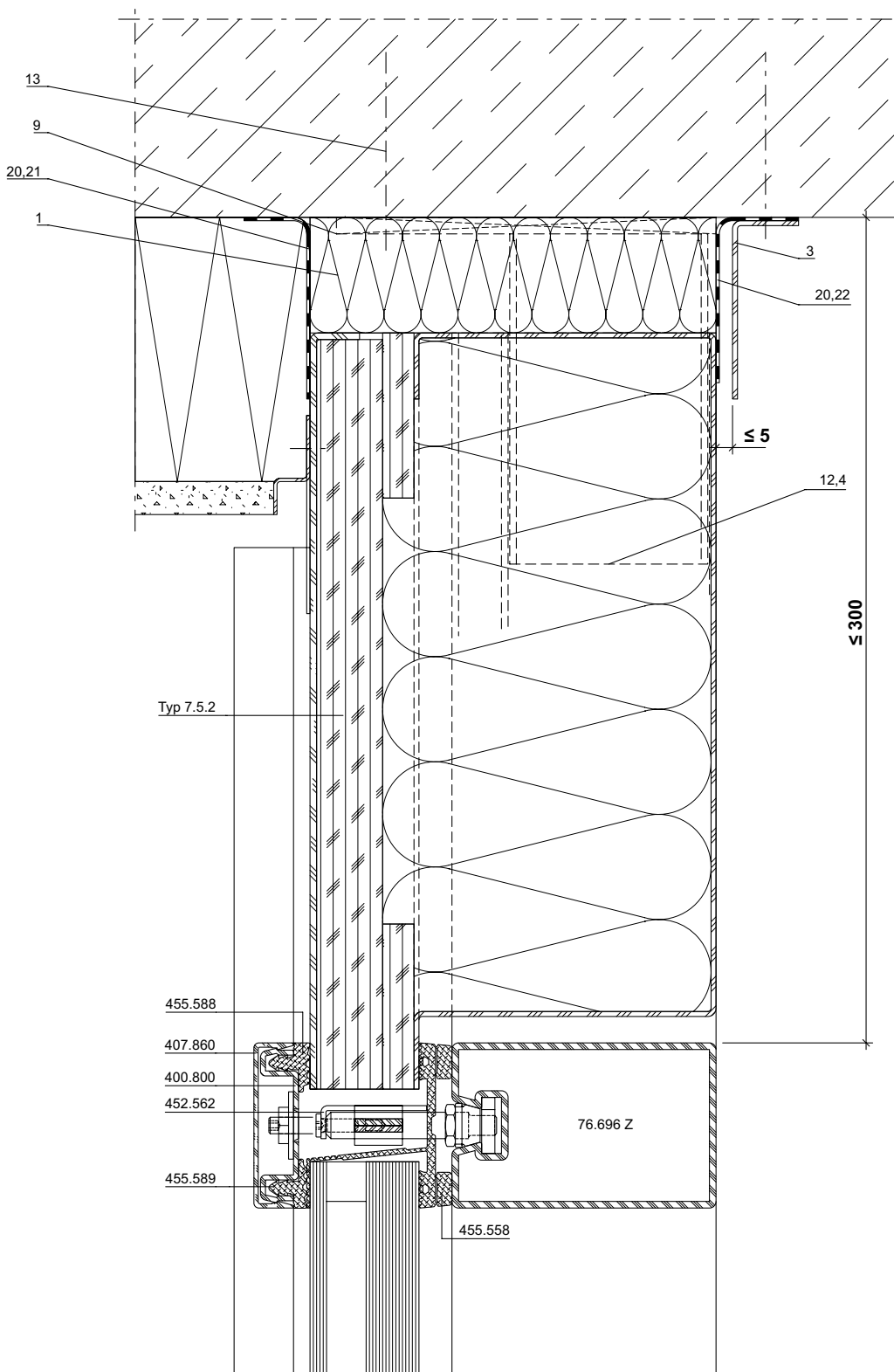

DXF DWG

51-0501-A-015

Anschlüsse am Bau im Masstab 1:2
Raccords au mur à l'échelle 1:2
Attachment to structure on scale 1:2

VISS Fire EI30 Fassade/Trennwand
VISS Fire EI30 façade/cloison
VISS Fire EI30 façade/partition wall

Deckenanschluss

Fixation au plafond

Intermediate floor attachment

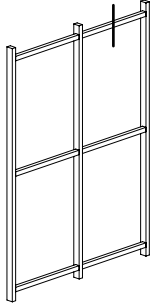
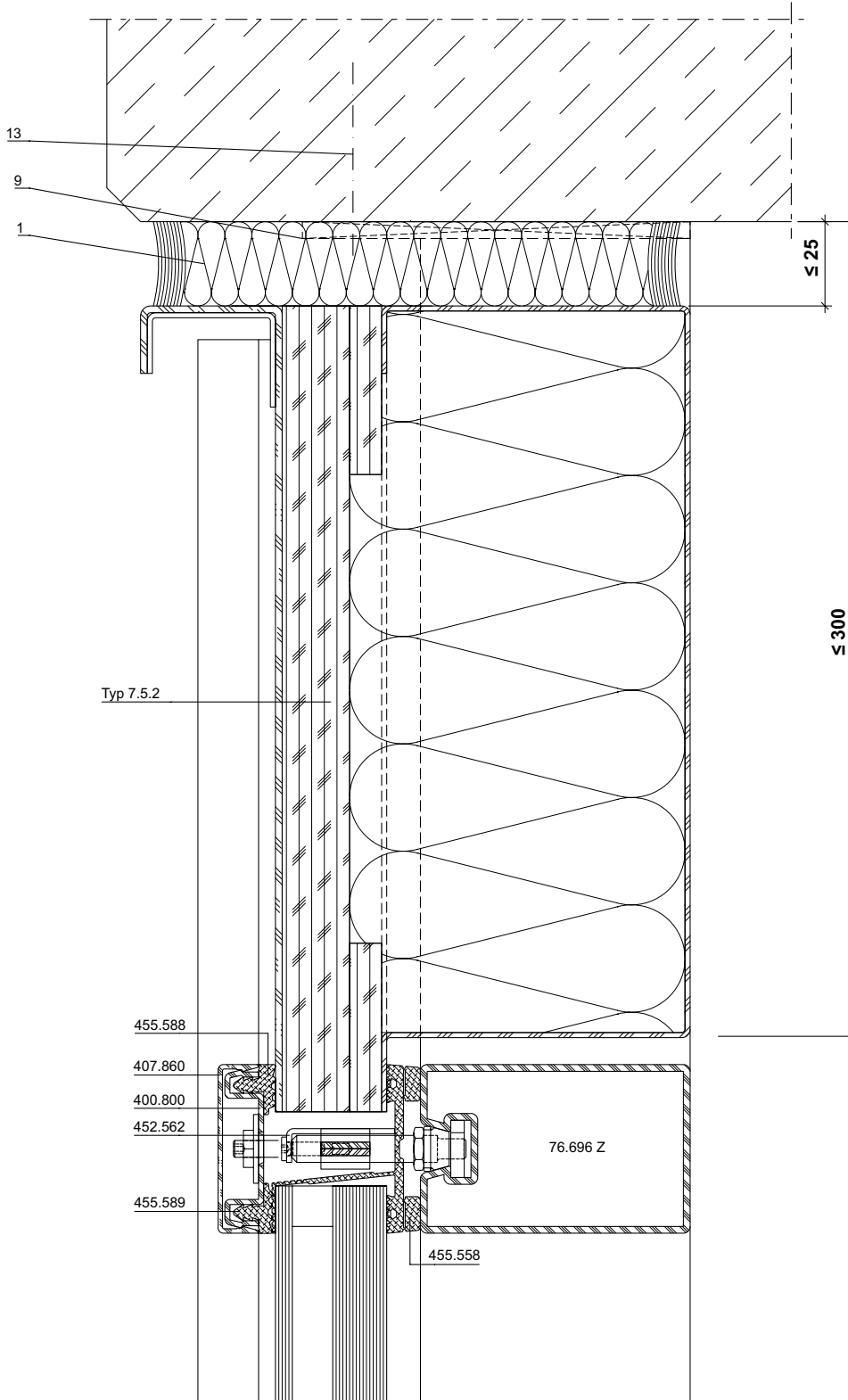

DXF DWG

51-0501-A-016

Anschlüsse am Bau im Massstab 1:2
Raccords au mur à l'échelle 1:2
Attachment to structure on scale 1:2

VISS Fire EI30 Fassade/Trennwand
VISS Fire EI30 façade/cloison
VISS Fire EI30 façade/partition wall

Deckenanschluss

Fixation au plafond

Intermediate floor attachment

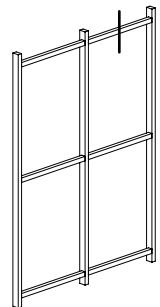
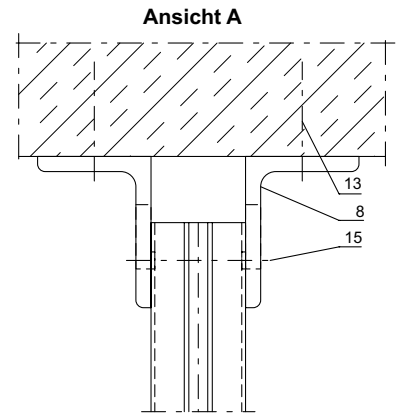
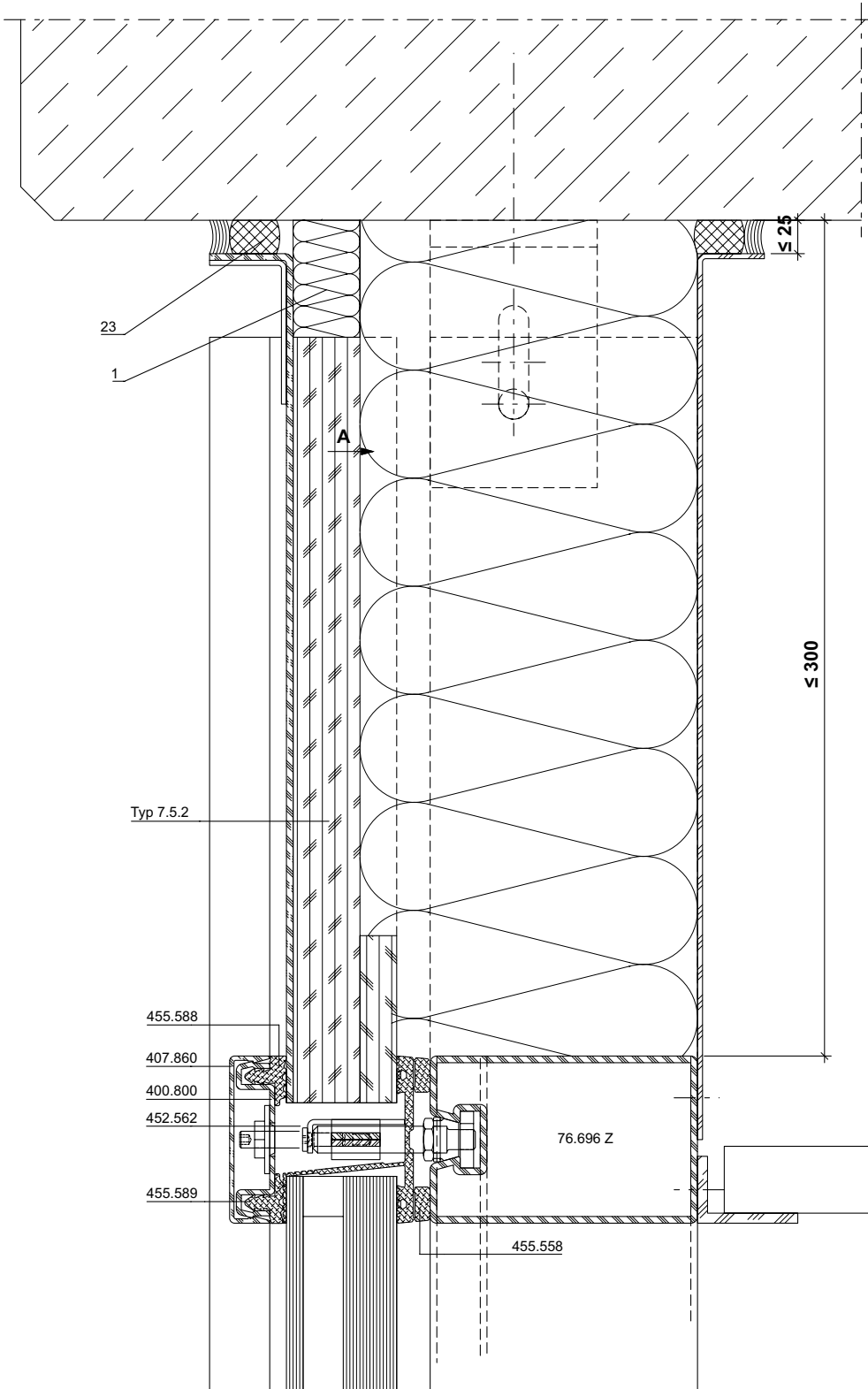

DXF **DWG**

51-0501-A-017

Deckenanschluss

Fixation au plafond

Intermediate floor attachment

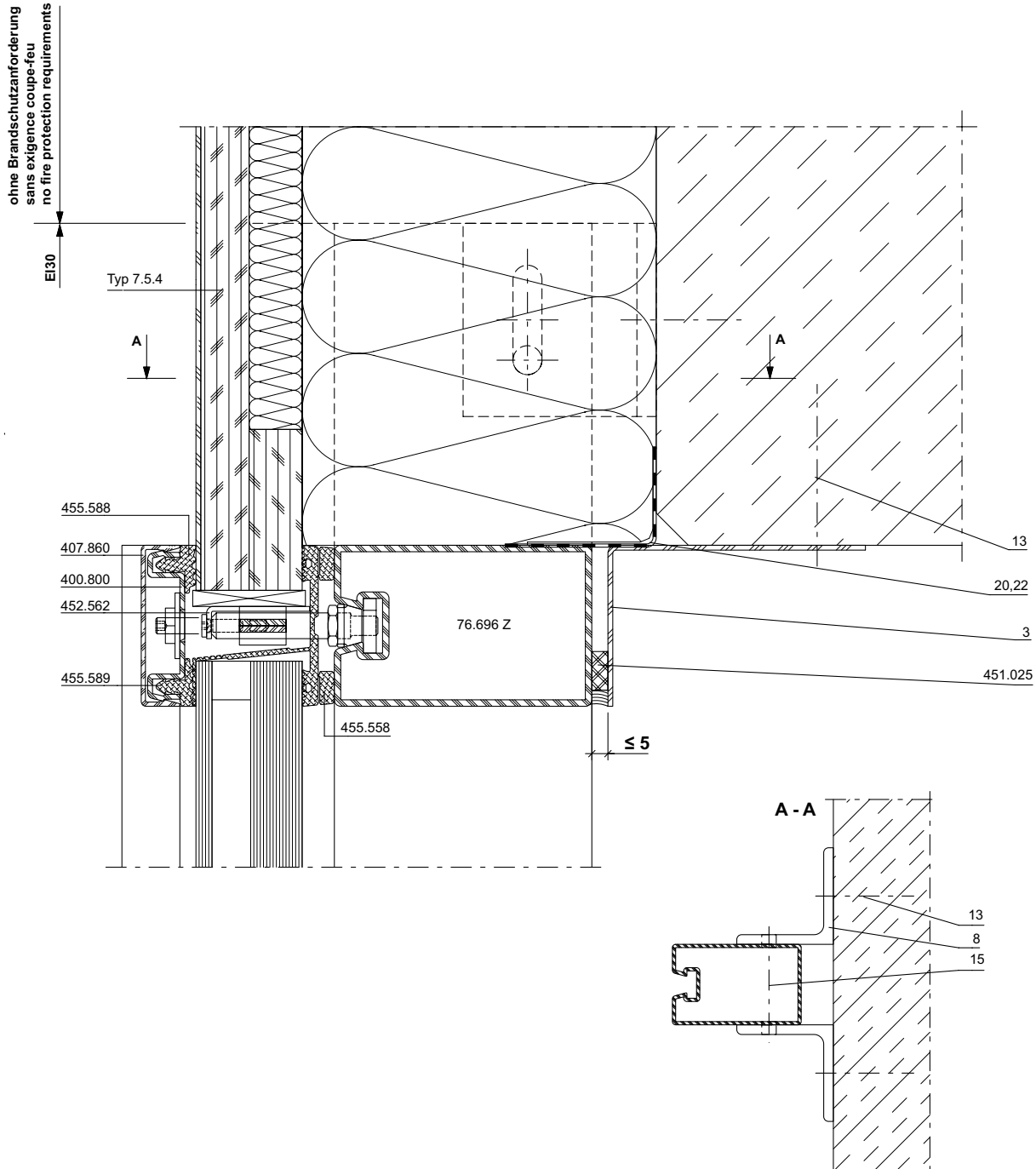

DXF DWG

51-0501-A-018

Anschlüsse am Bau im Massstab 1:2
Raccords au mur à l'échelle 1:2
Attachment to structure on scale 1:2

VISS Fire EI30 Fassade/Trennwand
VISS Fire EI30 façade/cloison
VISS Fire EI30 façade/partition wall

Deckenanschluss

Fixation au plafond

Intermediate floor attachment

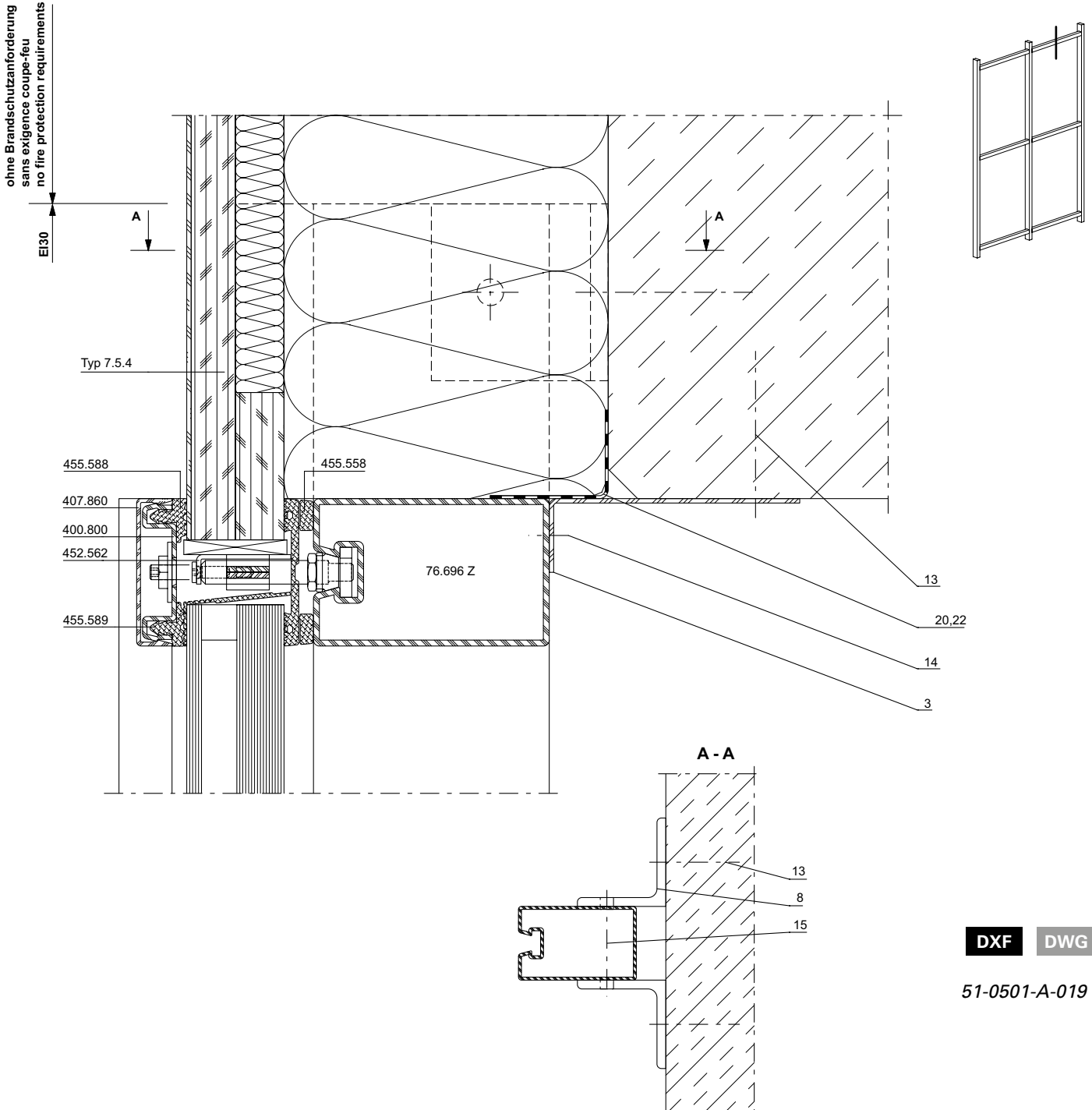

DXF **DWG**

51-0501-A-019

Deckenanschluss

Fixation au plafond

Intermediate floor attachment

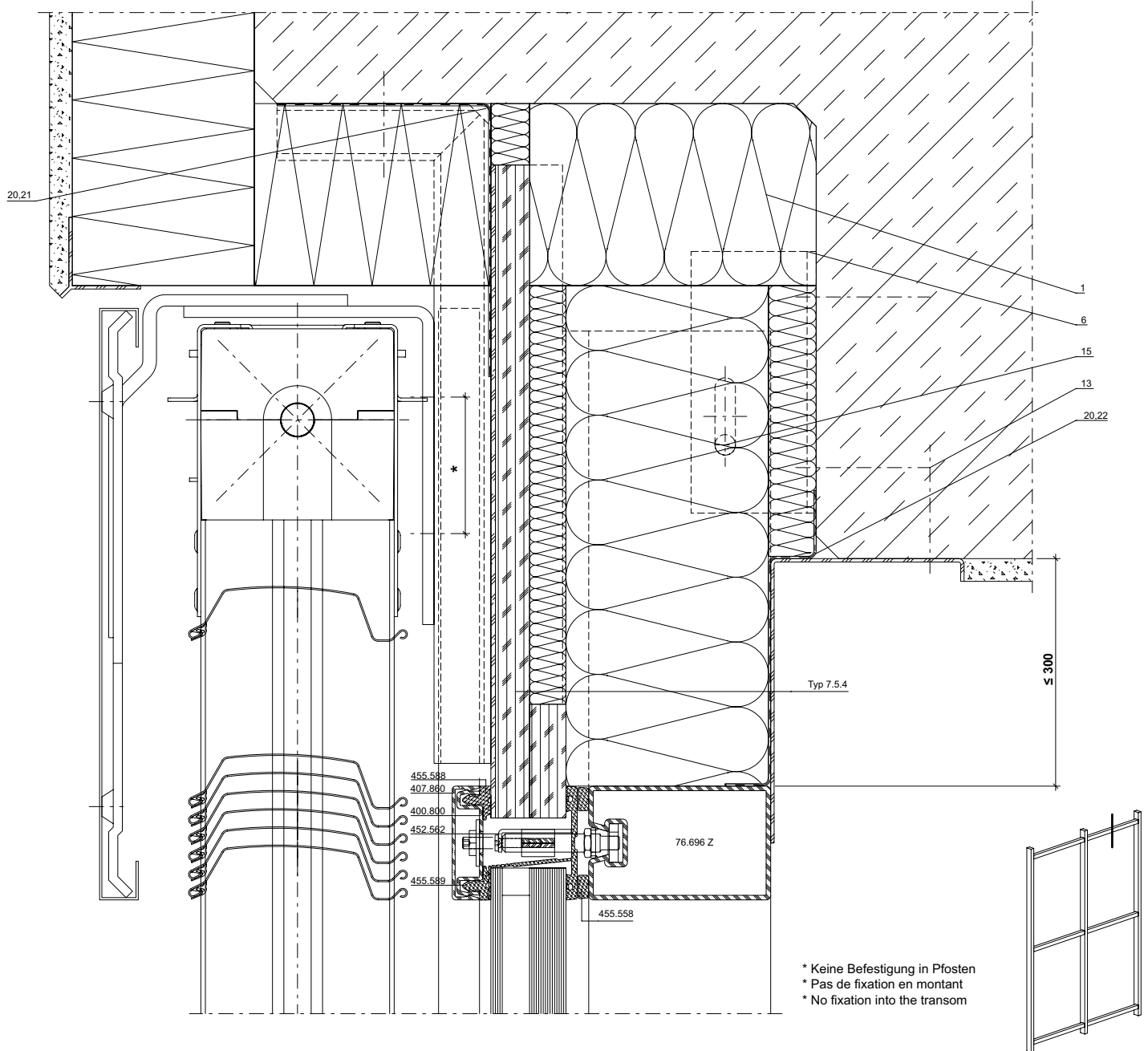

DXF DWG

51-0501-A-020

Deckenanschluss

Fixation au plafond

Intermediate floor attachment

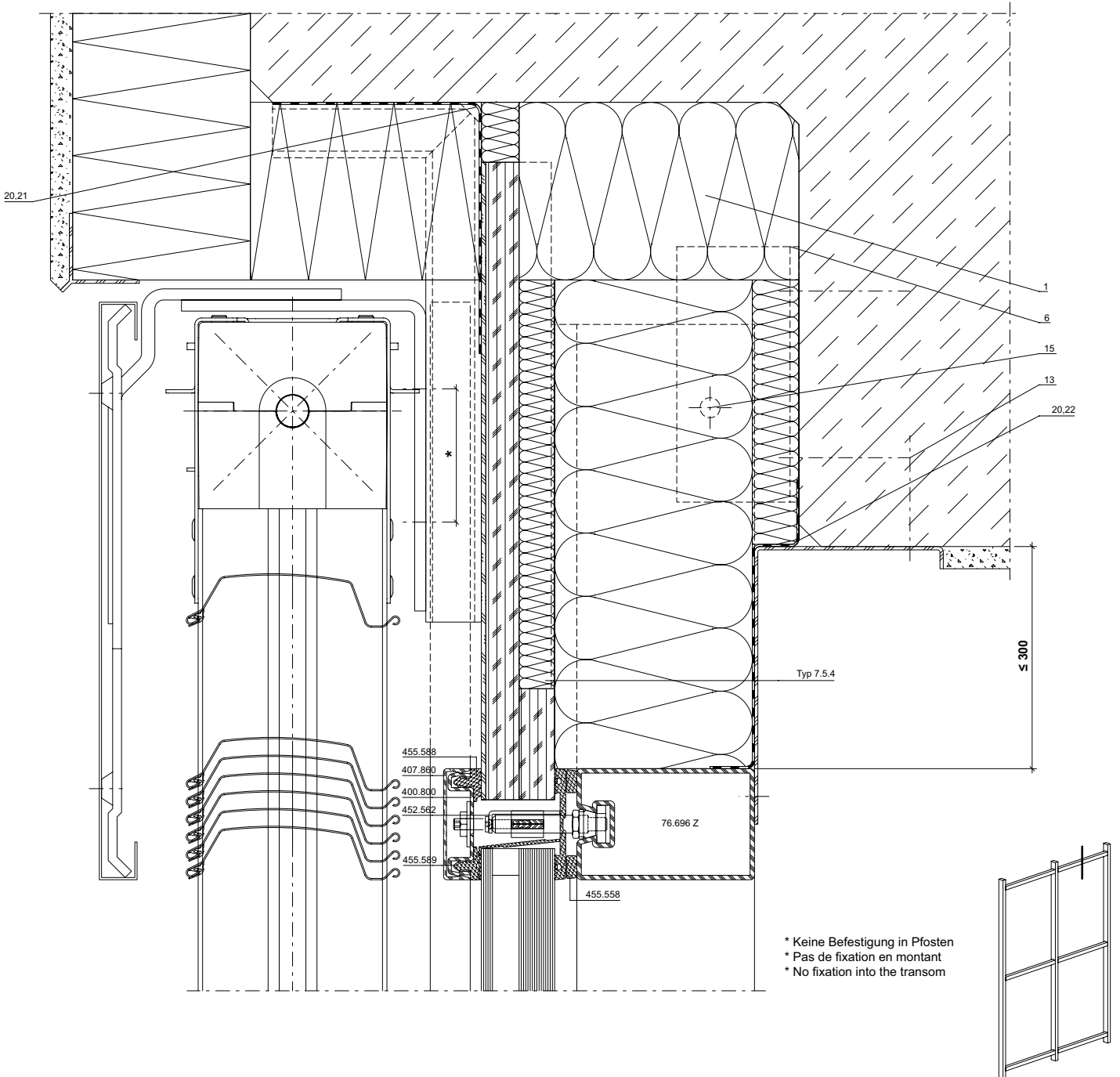

DXF DWG

51-0501-A-021

Anschlüsse am Bau im Masstab 1:2
 Raccords au mur à l'échelle 1:2
 Attachment to structure on scale 1:2

VISS Fire EI30 Fassade/Trennwand
 VISS Fire EI30 façade/cloison
 VISS Fire EI30 façade/partition wall

Deckenanschluss

Fixation au plafond

Intermediate floor attachment

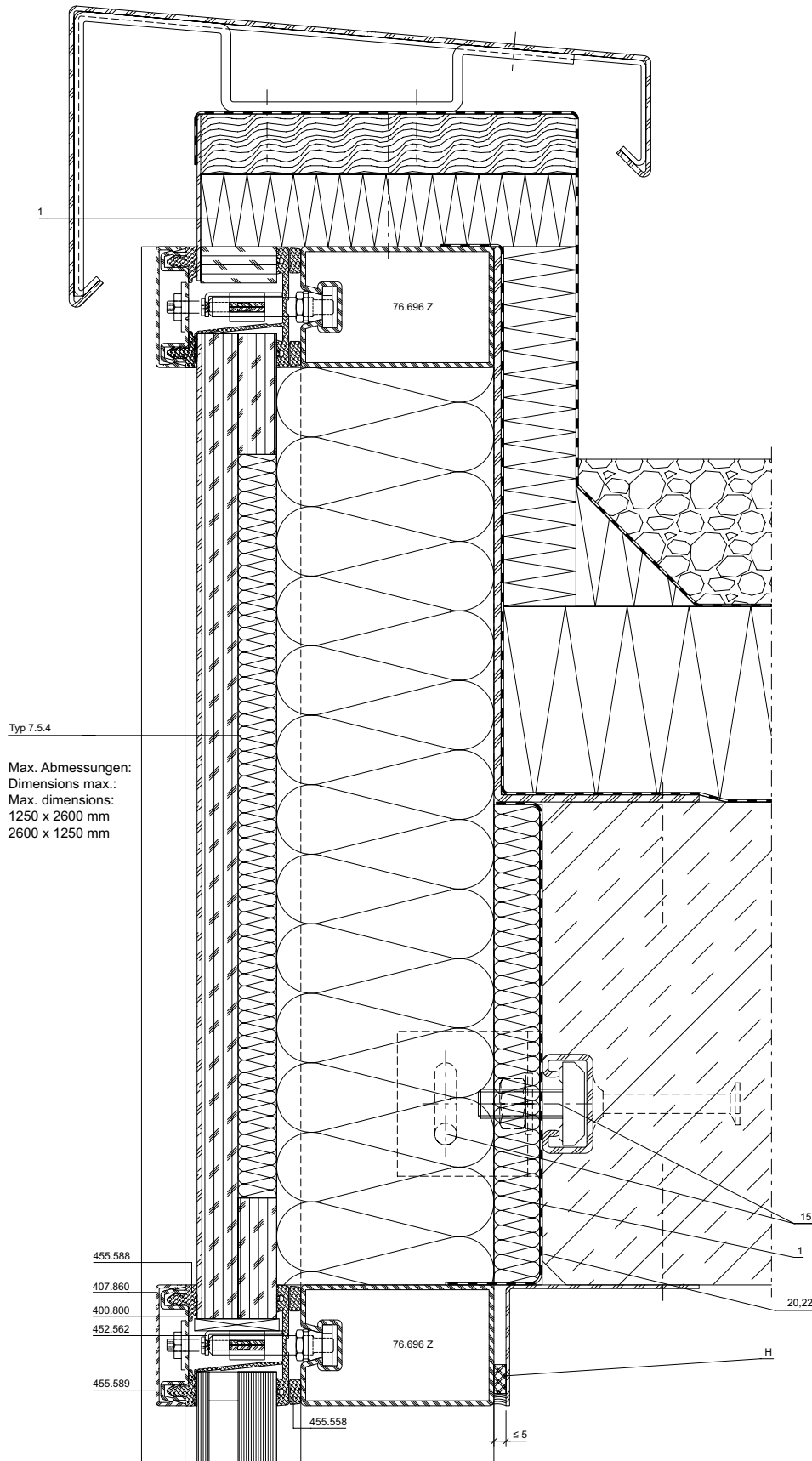

DXF **DWG**

51-0501-A-022

Anschlüsse am Bau im Massstab 1:2

Raccords au mur à l'échelle 1:2

Attachment to structure on scale 1:2

VISS Fire EI30 Fassade/Trennwand

VISS Fire EI30 façade/cloison

VISS Fire EI30 façade/partition wall

Deckenanschluss

Fixation au plafond

Intermediate floor attachment

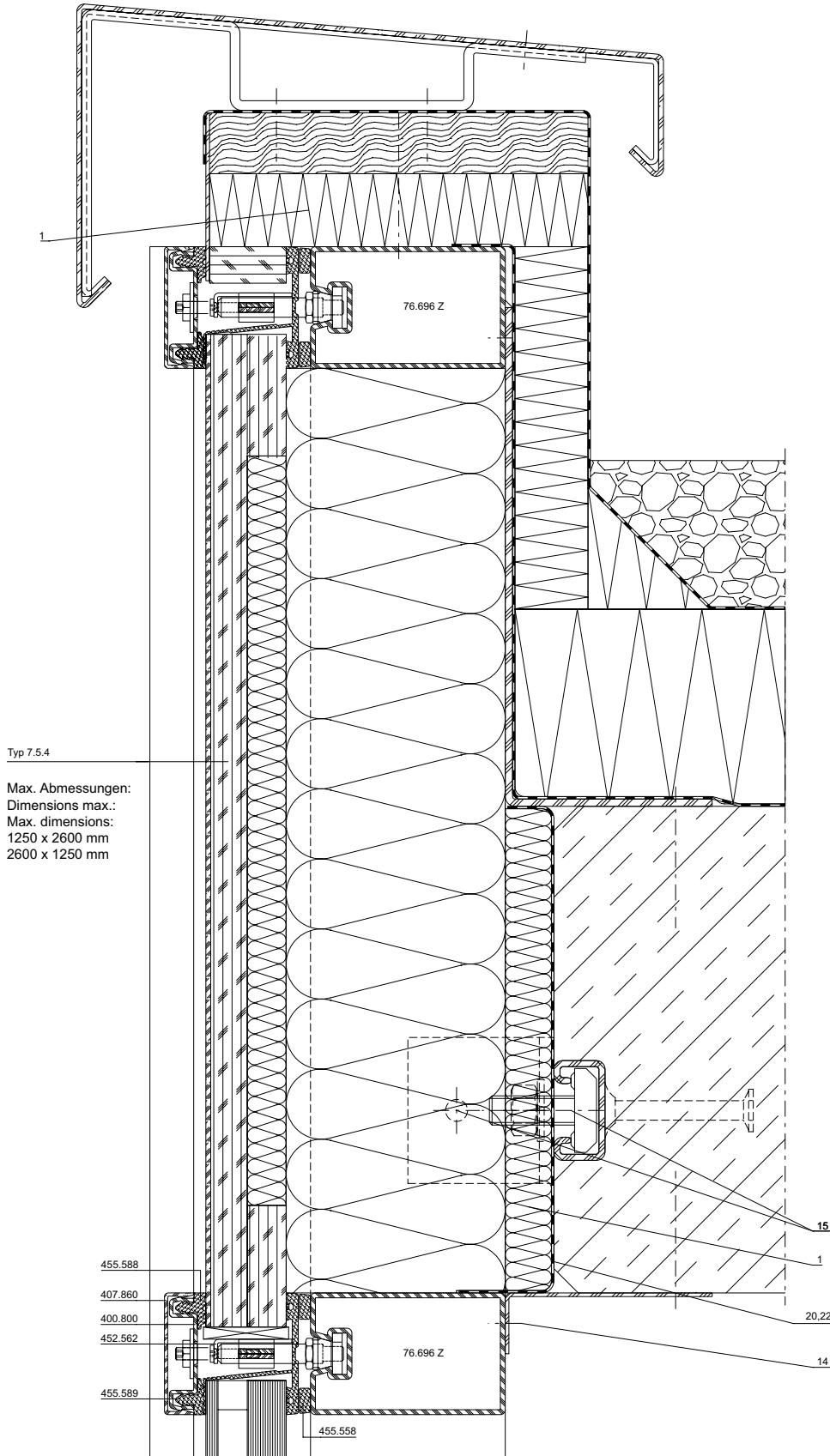

DXF DWG

51-0501-A-023

Boden- / Deckenanschluss vorge setzt Raccord intermédiaire

Forward-mounted floor /
 ceiling attachment

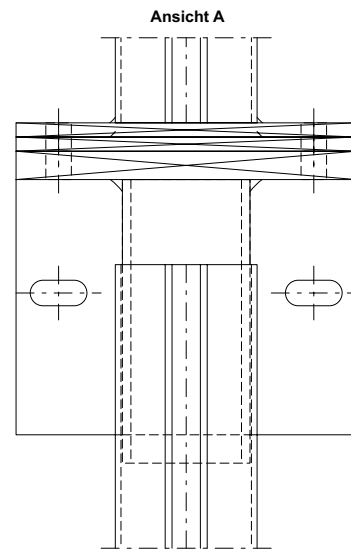
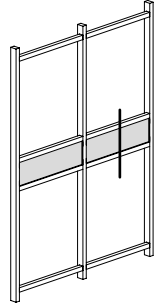
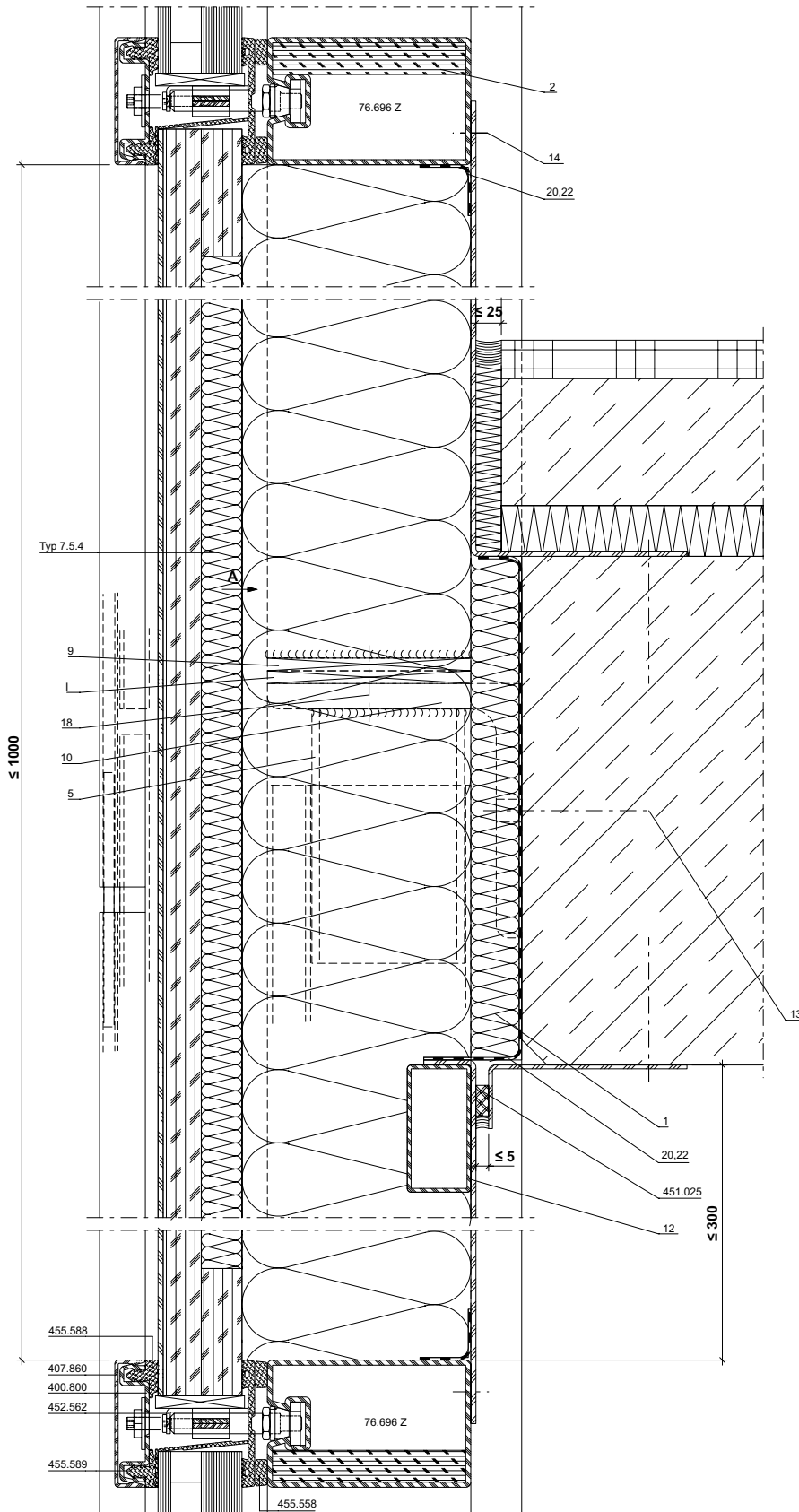

DXF DWG

51-0501-A-024

Anschlüsse am Bau im Massstab 1:2
Raccords au mur à l'échelle 1:2
Attachment to structure on scale 1:2

VISS Fire EI30 Fassade/Trennwand
VISS Fire EI30 façade/cloison
VISS Fire EI30 façade/partition wall

Boden- / Deckenanschluss vorge setzt Raccord intermédiaire

**Forward-mounted floor /
ceiling attachment**

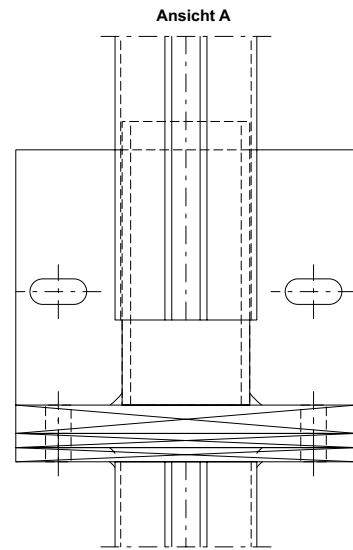
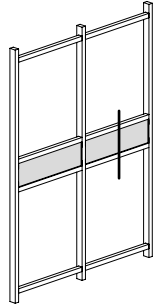
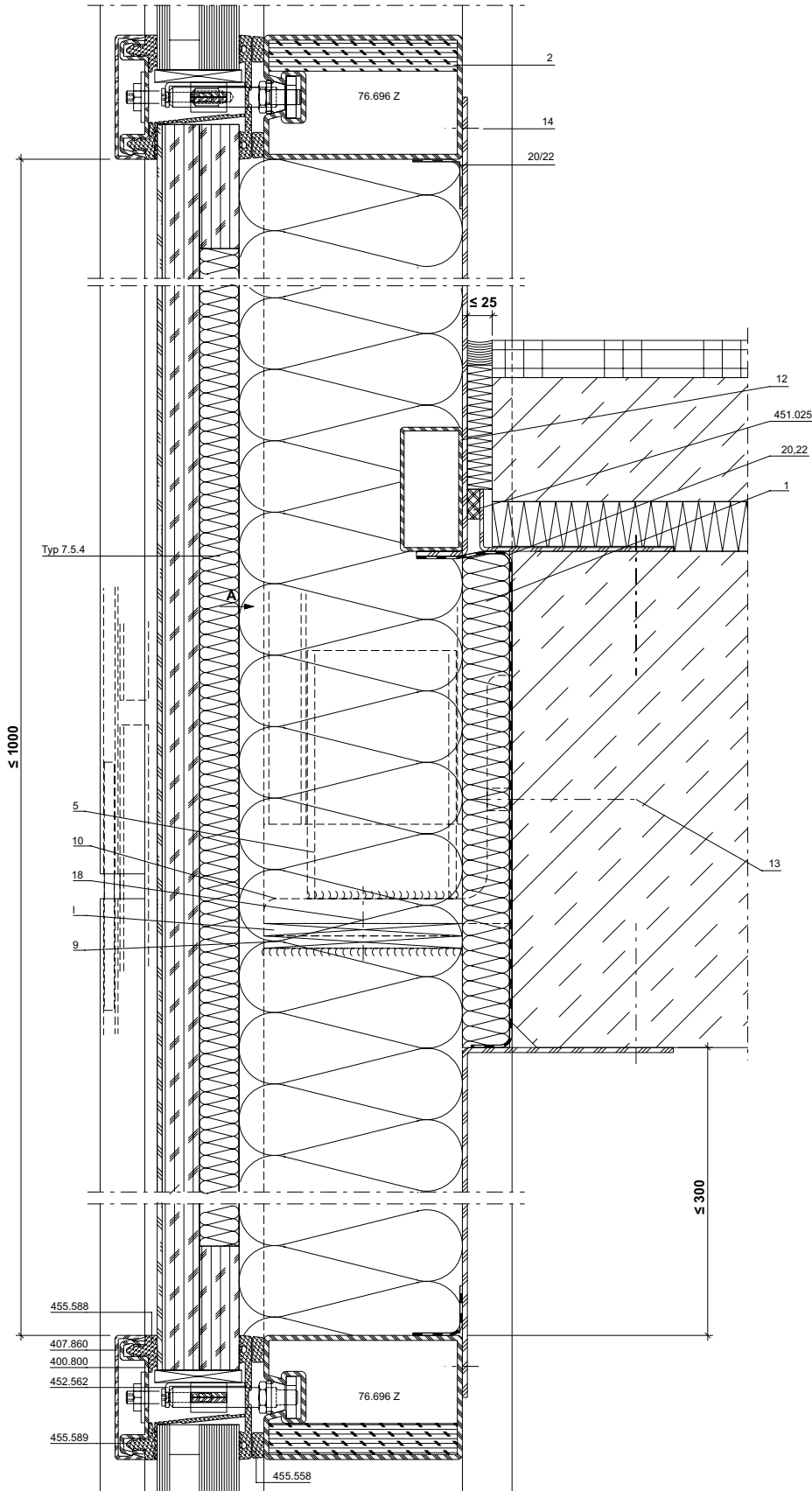

DXF DWG

51-0501-A-025

Boden- / Deckenanschluss vorge setzt

Raccord intermédiaire

Forward-mounted floor /
 ceiling attachment

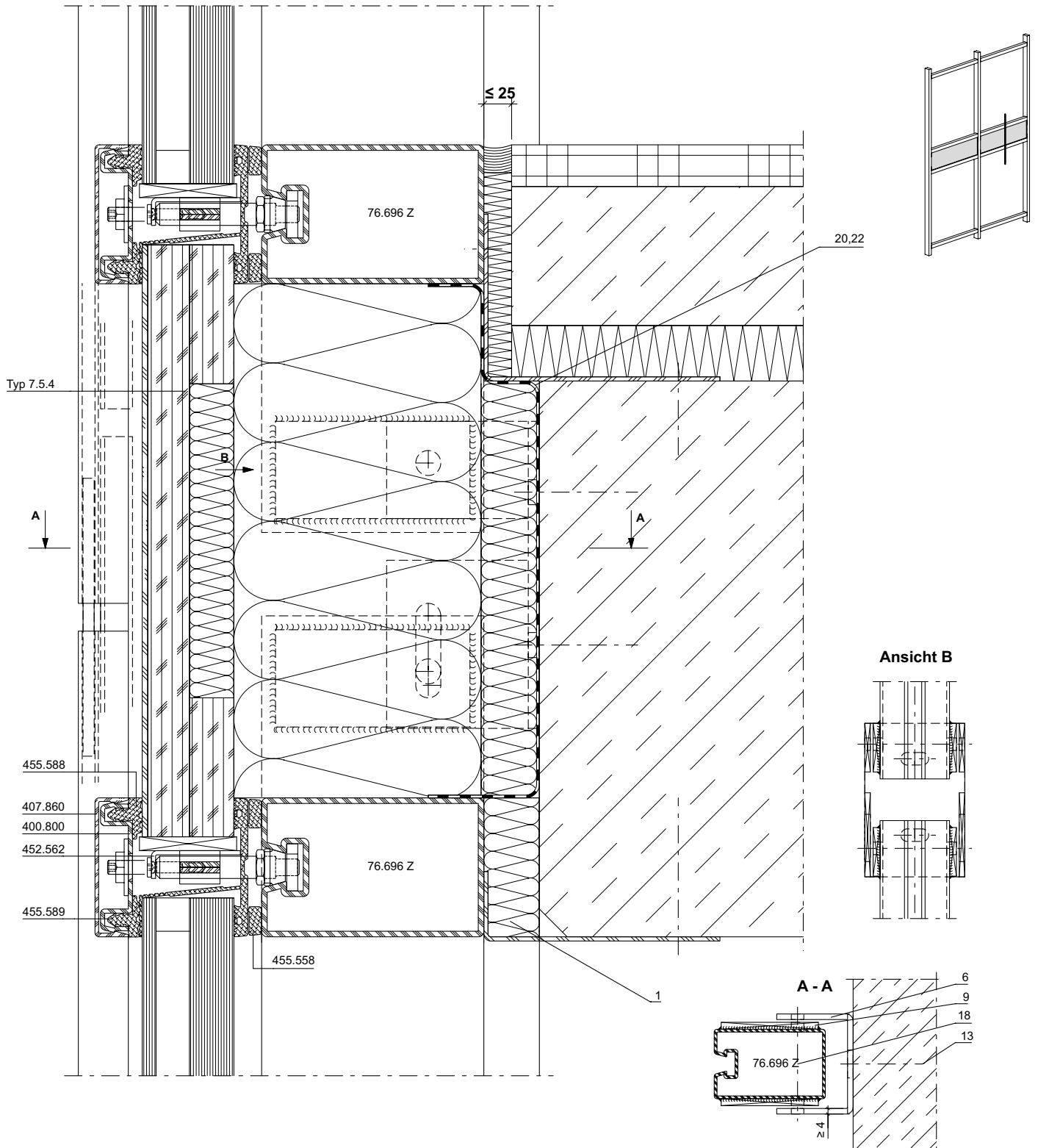

Ansicht B

A - A

DXF DWG

51-0501-A-028

Anschlüsse am Bau im Massstab 1:2
 Raccords au mur à l'échelle 1:2
 Attachment to structure on scale 1:2

VISS Fire EI30 Fassade/Trennwand
 VISS Fire EI30 façade/cloison
 VISS Fire EI30 façade/partition wall

Boden- / Deckenanschluss vorge setzt

Raccord intermédiaire

Forward-mounted floor /
 ceiling attachment

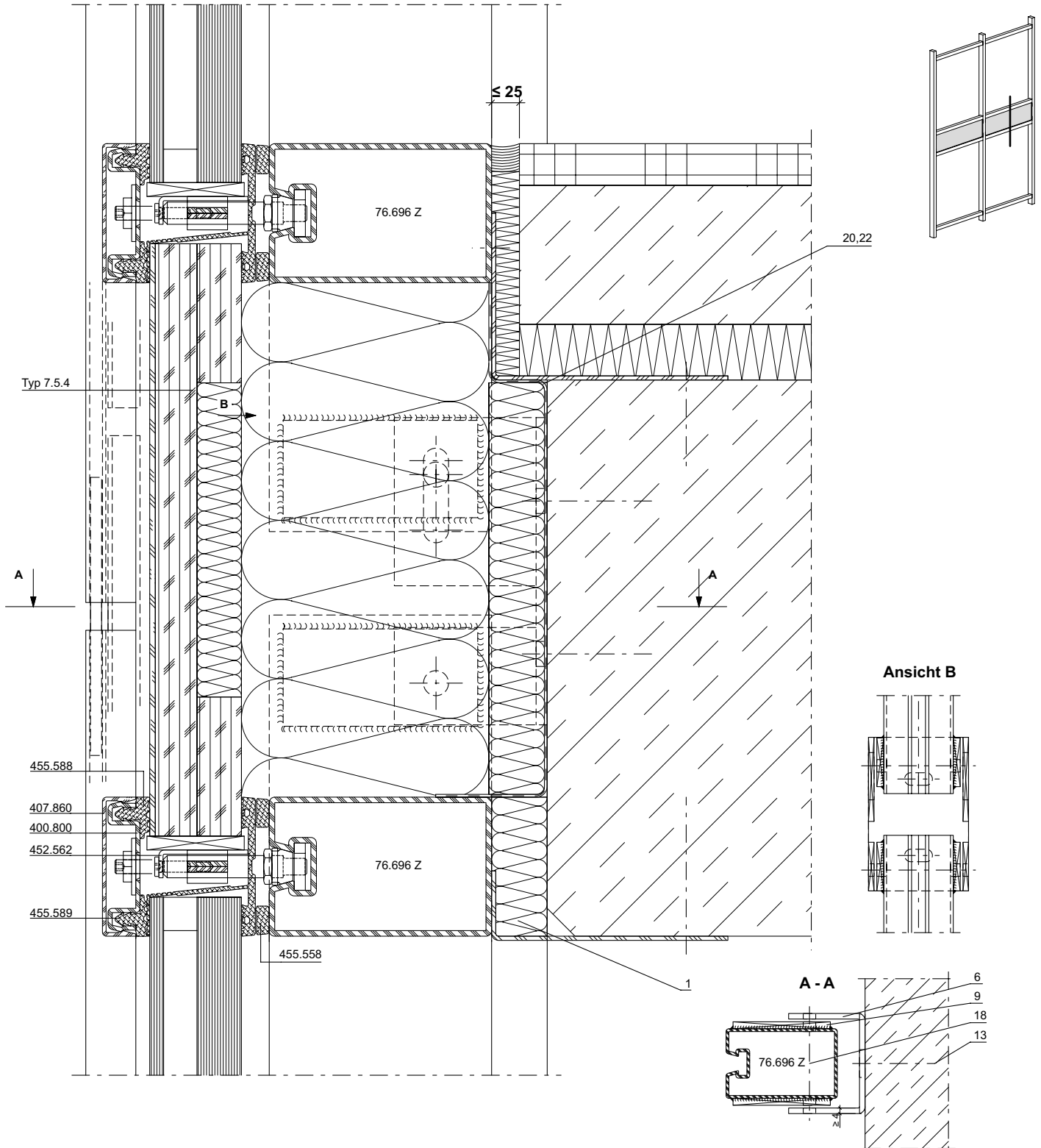

DXF DWG

51-0501-A-029

Boden- / Deckenanschluss vorge setzt

Raccord intermédiaire

Forward-mounted floor /
 ceiling attachment

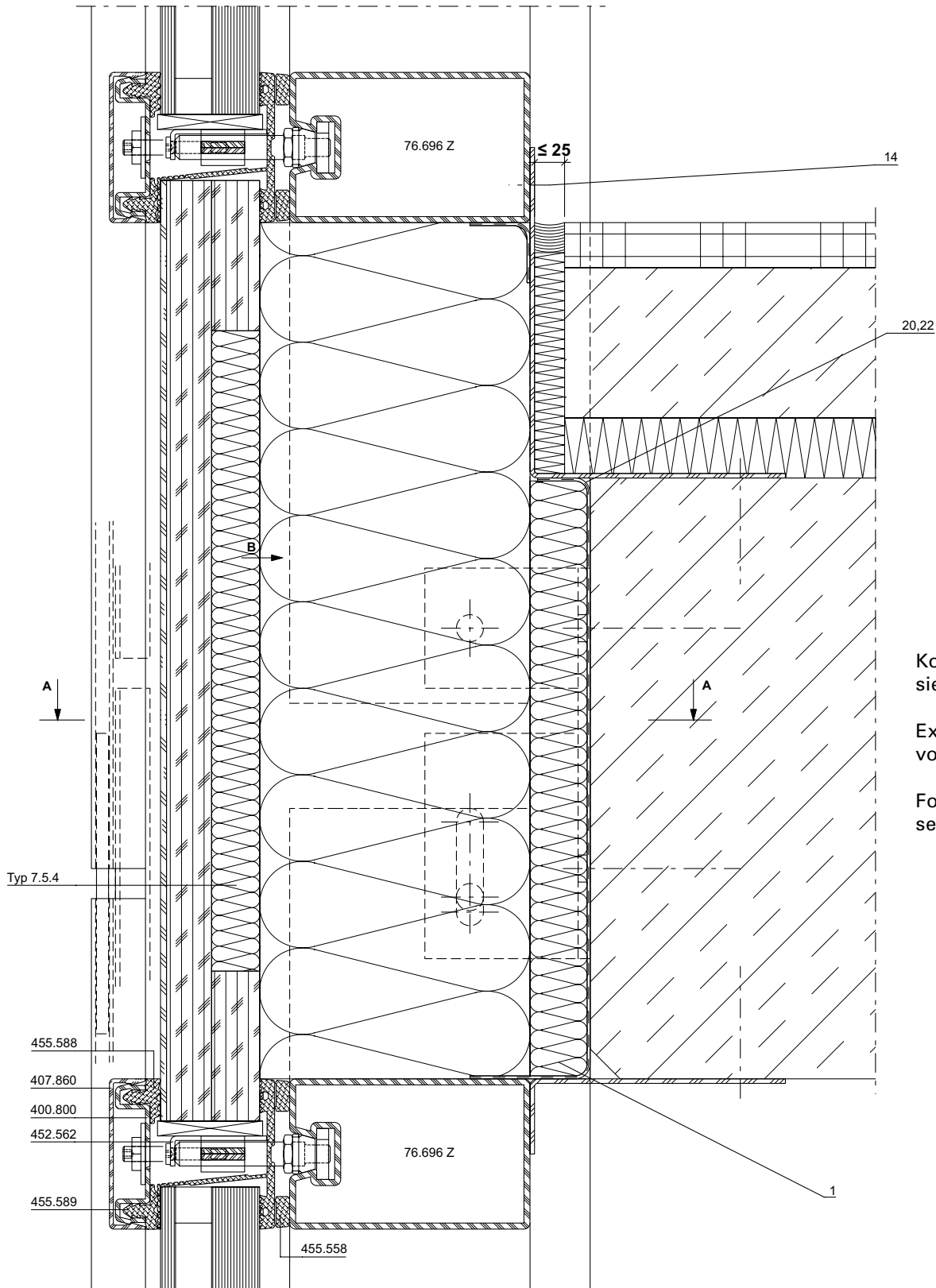

Konsolenausführungen
 siehe Seite 51-85.

Exécutions des platines,
 voir page 51-85.

For bracket designs,
 see page 51-85.

DXF DWG

51-0501-A-026

Anschlüsse am Bau im Massstab 1:2
 Raccords au mur à l'échelle 1:2
 Attachment to structure on scale 1:2

VISS Fire EI30 Fassade/Trennwand
 VISS Fire EI30 façade/cloison
 VISS Fire EI30 façade/partition wall

Boden- / Deckenanschluss vorge setzt

Raccord intermédiaire

Forward-mounted floor /
 ceiling attachment

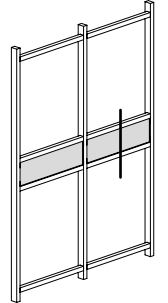
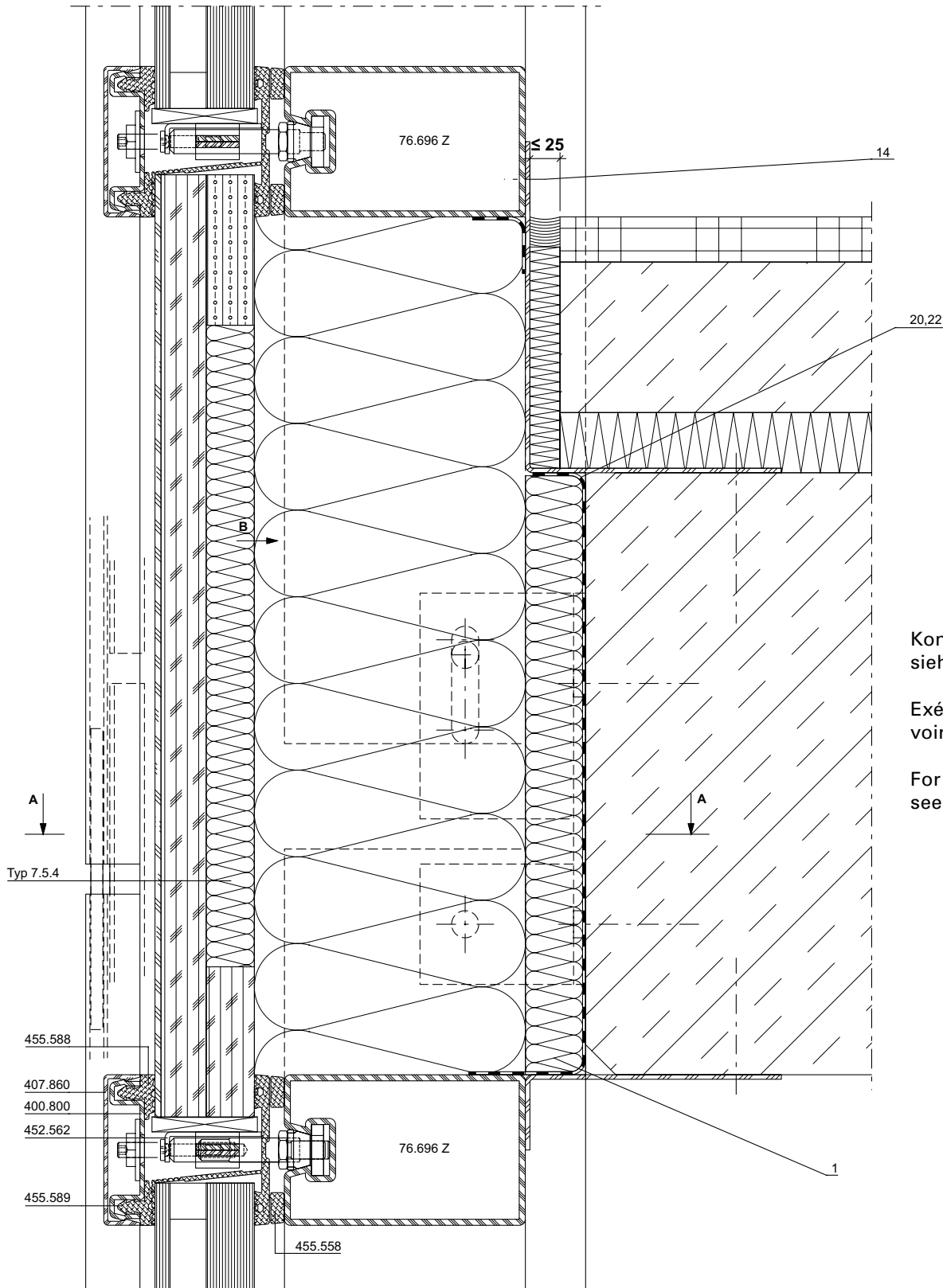

Konsolenausführungen
 siehe Seite 51-85.
 Exécutions des platines,
 voir page 51-85.
 For bracket designs,
 see page 51-85.

DXF **DWG**

51-0501-A-027

Boden- / Deckenanschluss vorge setzt

Raccord intermédiaire

Forward-mounted floor /
 ceiling attachment

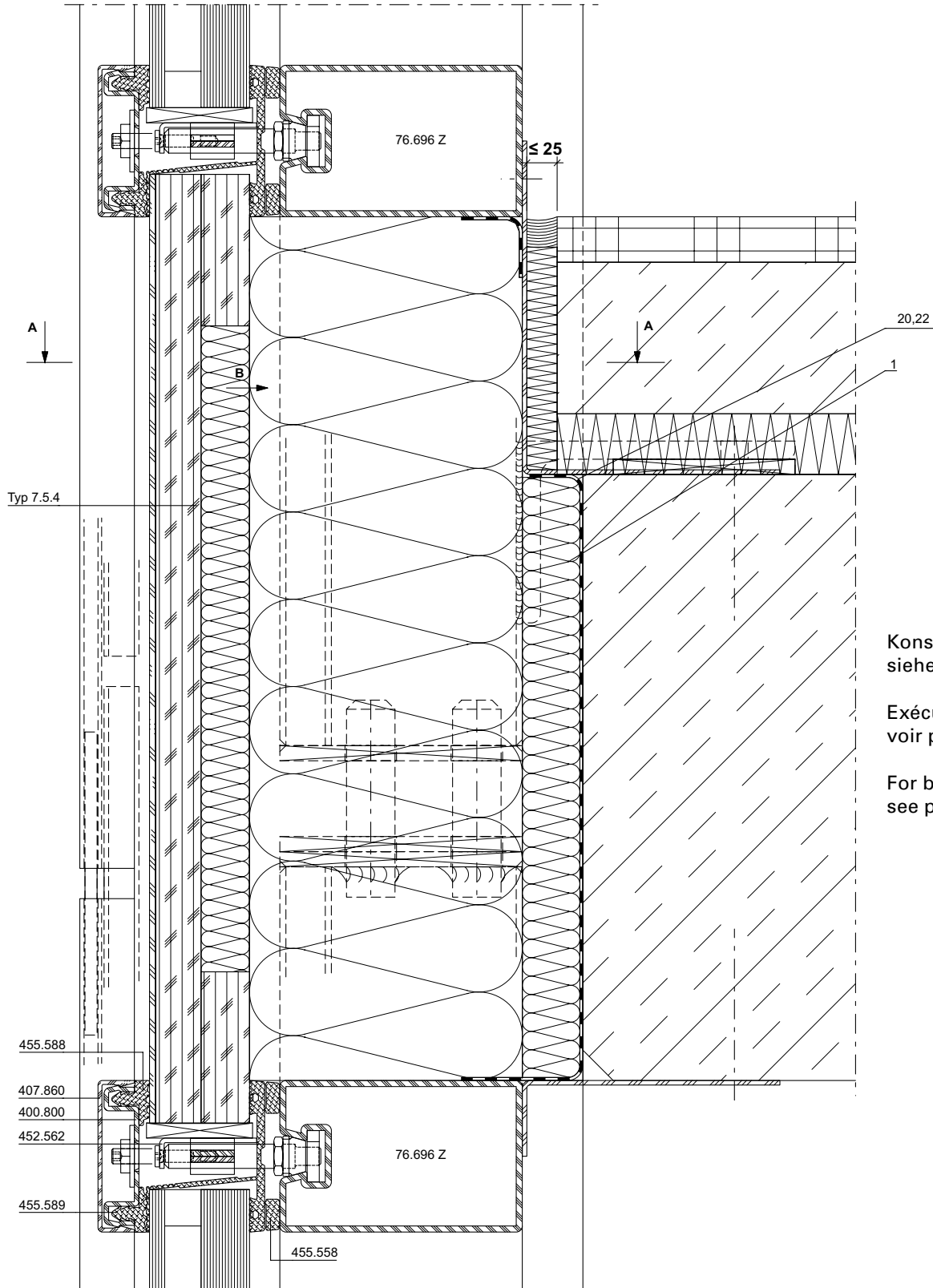

Konsolenausführungen
 siehe Seite 51-87.

Exécutions des platines,
 voir page 51-87.

For bracket designs,
 see page 51-87.

DXF DWG

51-0501-A-034

Anschlüsse am Bau im Massstab 1:2
 Raccords au mur à l'échelle 1:2
 Attachment to structure on scale 1:2

VISS Fire EI30 Fassade/Trennwand
 VISS Fire EI30 façade/cloison
 VISS Fire EI30 façade/partition wall

Boden- / Deckenanschluss vorge setzt

Raccord intermédiaire

Forward-mounted floor /
 ceiling attachment

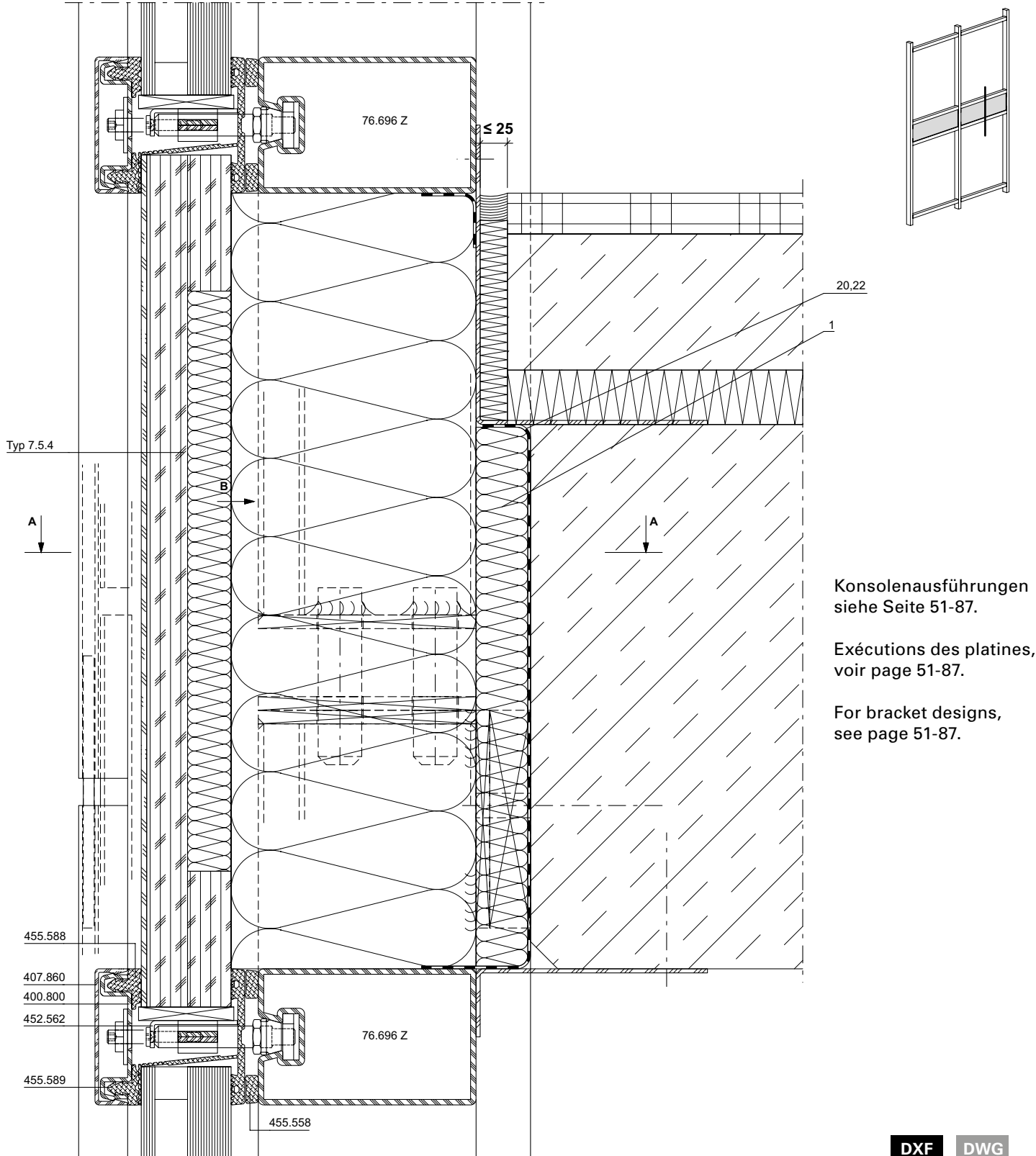

Konsolenausführungen
 siehe Seite 51-87.

Exécutions des platines,
 voir page 51-87.

For bracket designs,
 see page 51-87.

DXF **DWG**

51-0501-A-035

Mögliche Konsolenausführungen

Possibilités de platine

Possible bracket designs

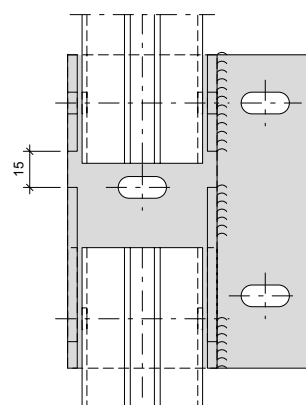
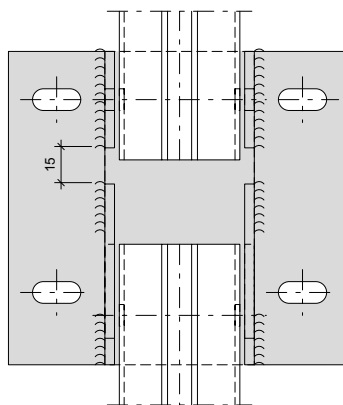
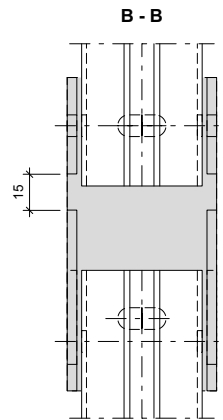
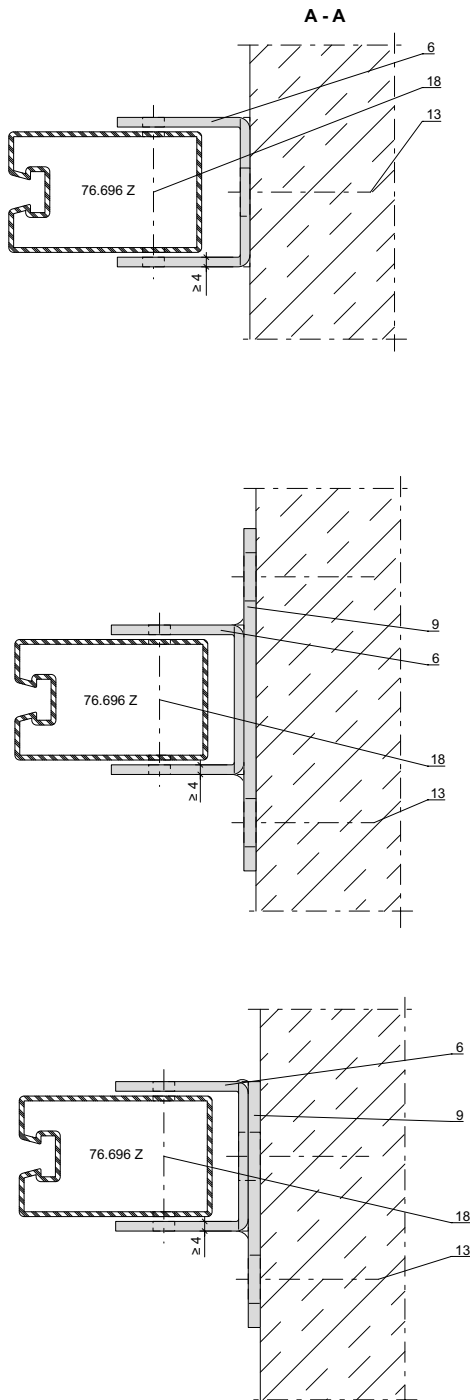

DXF **DWG** 51-0501-A-026

DXF **DWG** 51-0501-A-027

DXF **DWG** 51-0501-A-030

DXF **DWG** 51-0501-A-031

DXF **DWG** 51-0501-A-032

DXF **DWG** 51-0501-A-033

Sofern vorhanden sind die Masse einzuhalten, ansonsten ist die Auslegung Aufgabe des Metallbauers/Planers.

Hinweis: Konsolen können auch gespiegelt ausgeführt werden. Oben Festlager, unten Loslager.

Respecter si nécessaire les cotes si disponibles, sinon le dimensionnement relève des compétences du constructeur métallique/du planificateur.

Remarque: les consoles peuvent aussi être exécutées de manière réfléchie. En haut palier fixe, en bas palier libre.

If available, the dimensions must be observed, as otherwise the configuration will have to be carried out by the metal fabricator / developer.

Note: Brackets can also be designed as a mirror image. Fixed bearing at top, sliding bearing at bottom.

Mögliche Konsolenausführungen

Possibilités de platine

Possible bracket designs

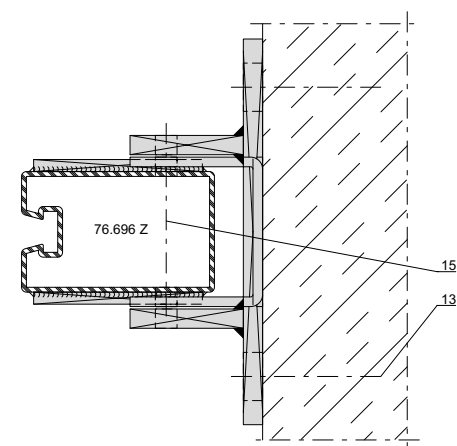
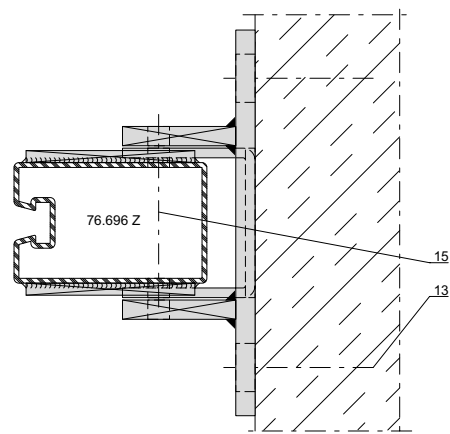
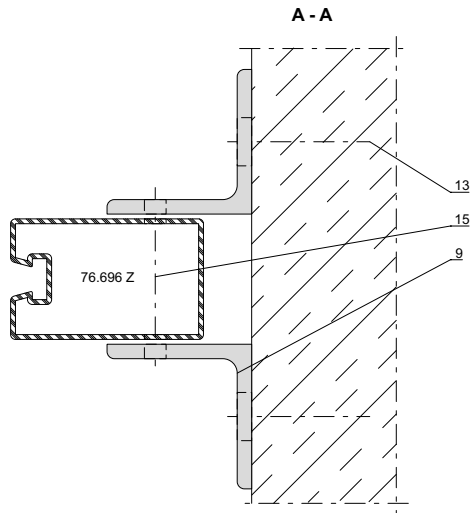

Sofern vorhanden sind die Masse einzuhalten, ansonsten ist die Auslegung Aufgabe des Metallbauers/Planers.

Hinweis: Konsolen können auch gespiegelt ausgeführt werden. Oben Festlager, unten Loslager.

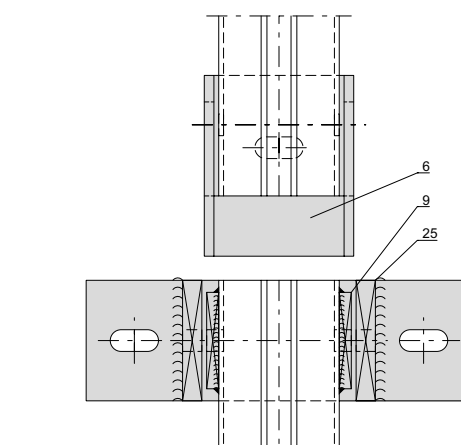
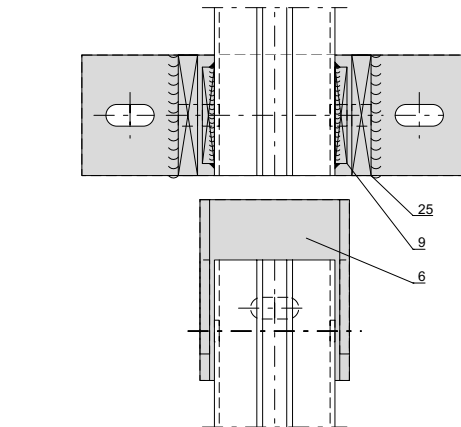
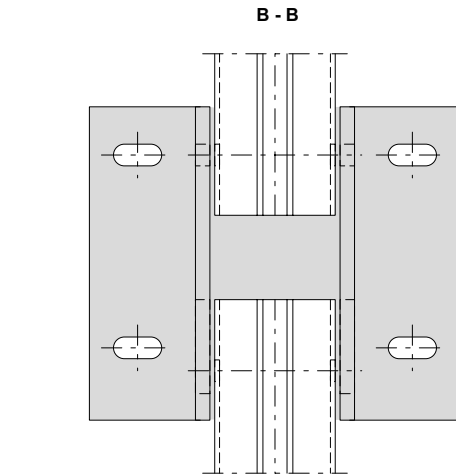

Respecter si nécessaire les cotes si disponibles, sinon le dimensionnement relève des compétences du constructeur métallique/du planificateur.

Remarque: les consoles peuvent aussi être exécutées de manière réfléchi. En haut palier fixe, en bas palier libre.

DXF **DWG** 51-0501-A-036

DXF **DWG** 51-0501-A-037

DXF **DWG** 51-0501-A-038

DXF **DWG** 51-0501-A-039

If available, the dimensions must be observed, as otherwise the configuration will have to be carried out by the metal fabricator / developer.

Note: Brackets can also be designed as a mirror image. Fixed bearing at top, sliding bearing at bottom.

Mögliche Konsolenausführungen

Possibilités de platine

Possible bracket designs

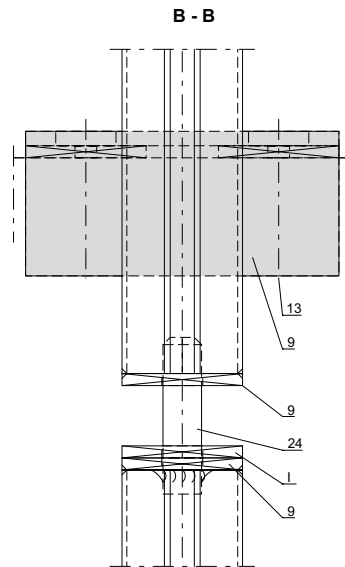
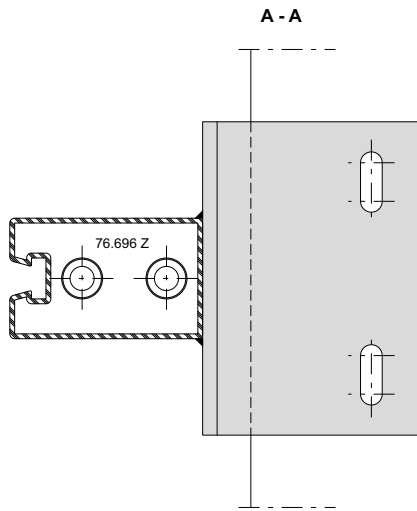

DXF **DWG** 51-0501-A-034

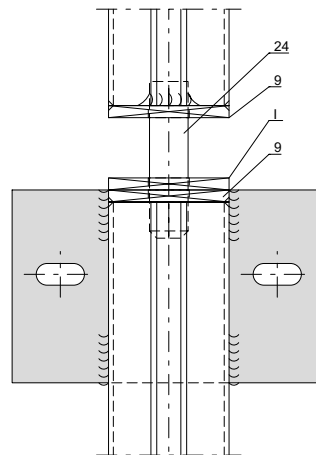
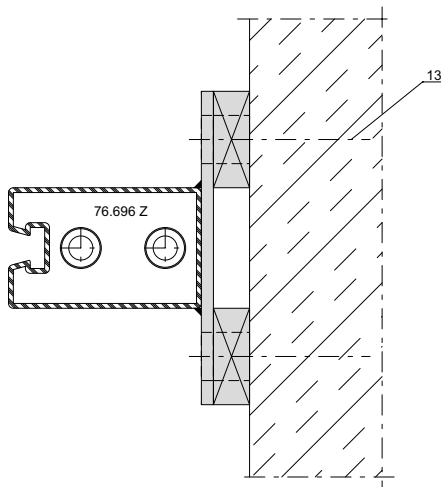

DXF **DWG** 51-0501-A-035

Sofern vorhanden sind die Masse einzuhalten, ansonsten ist die Auslegung Aufgabe des Metallbauers/Planers.

Hinweis: Konsolen können auch gespiegelt ausgeführt werden. Oben Festlager, unten Loslager.

Respecter si nécessaire les cotes si disponibles, sinon le dimensionnement relève des compétences du constructeur métallique/du planificateur.

Remarque: les consoles peuvent aussi être exécutées de manière réfléchie. En haut palier fixe, en bas palier libre.

If available, the dimensions must be observed, as otherwise the configuration will have to be carried out by the metal fabricator / developer.

Note: Brackets can also be designed as a mirror image. Fixed bearing at top, sliding bearing at bottom.

Anschlüsse am Bau im Massstab 1:2

Raccords au mur à l'échelle 1:2

Attachment to structure on scale 1:2

VISS Fire EI30 Fassade/Trennwand

VISS Fire EI30 façade/cloison

VISS Fire EI30 façade/partition wall

Wandanschluss

Raccordement au mur

Wall attachment

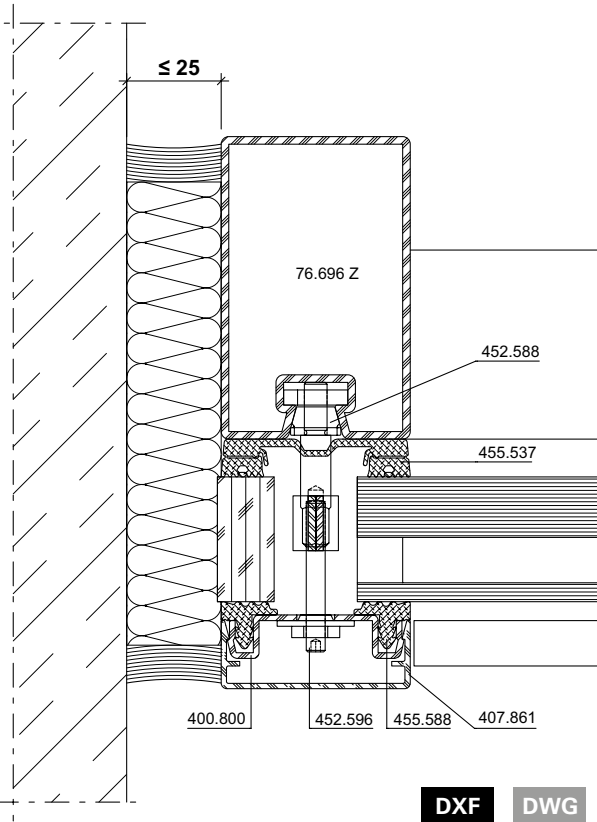

51-0501-A-040

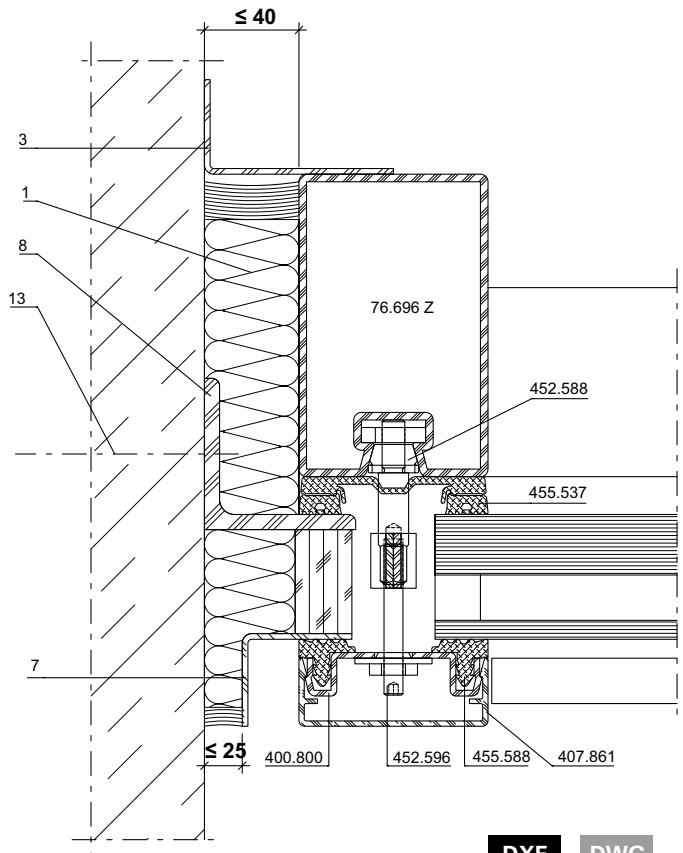

51-0501-A-042

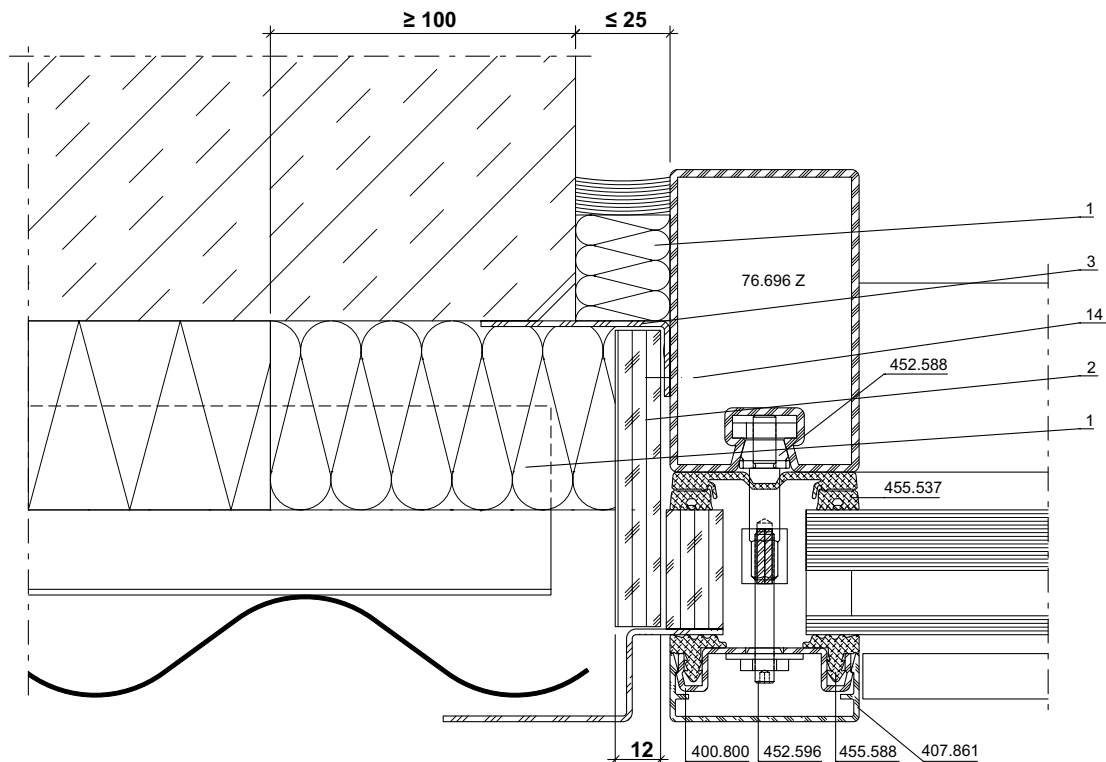

51-0501-A-043

Wandanschluss

Raccordement au mur

Wall attachment

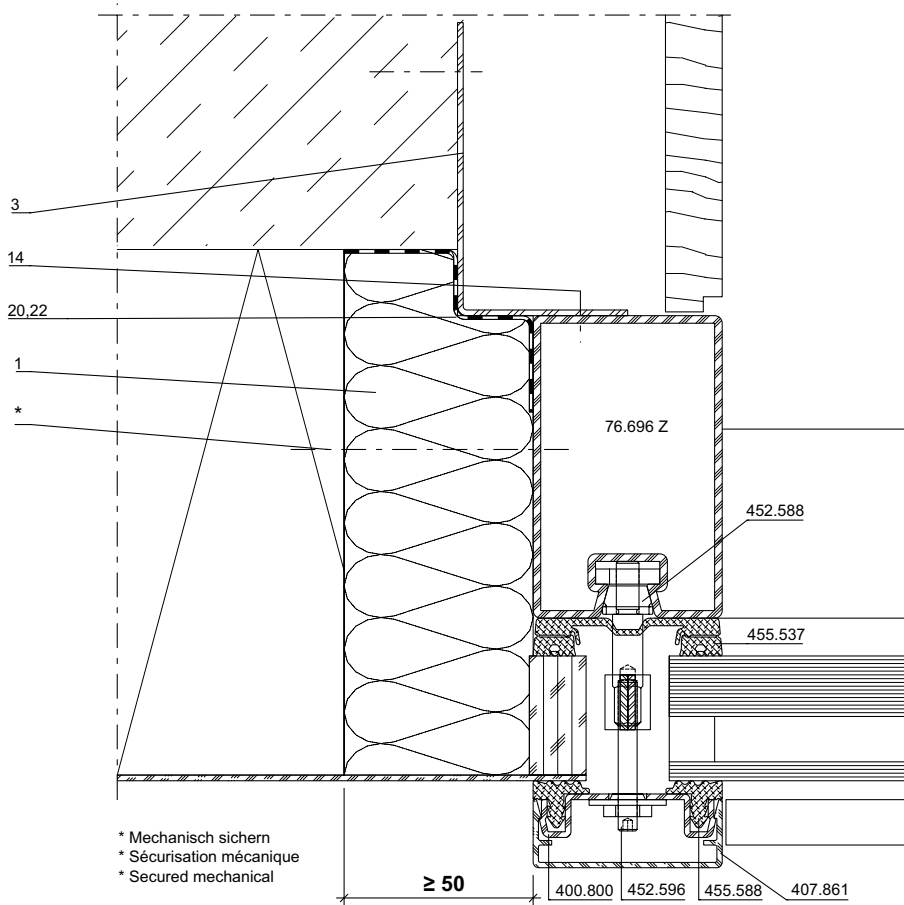

DXF DWG

51-0501-A-044

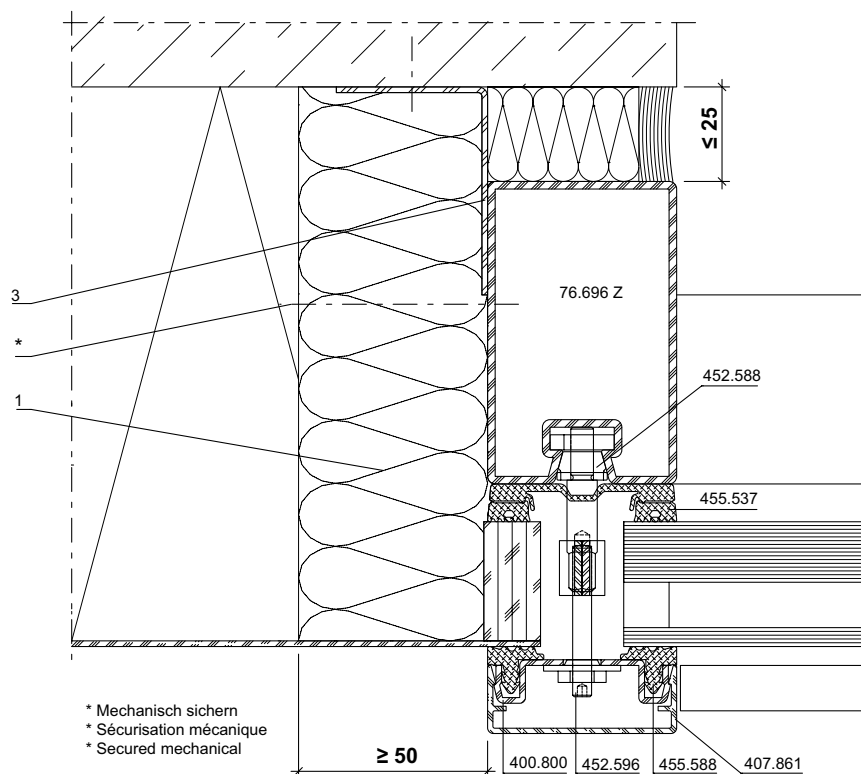

DXF DWG

51-0501-A-045

Anschlüsse am Bau im Massstab 1:2

Raccords au mur à l'échelle 1:2

Attachment to structure on scale 1:2

VISS Fire EI30 Fassade/Trennwand

VISS Fire EI30 façade/cloison

VISS Fire EI30 façade/partition wall

Wandanschluss

Raccordement au mur

Wall attachment

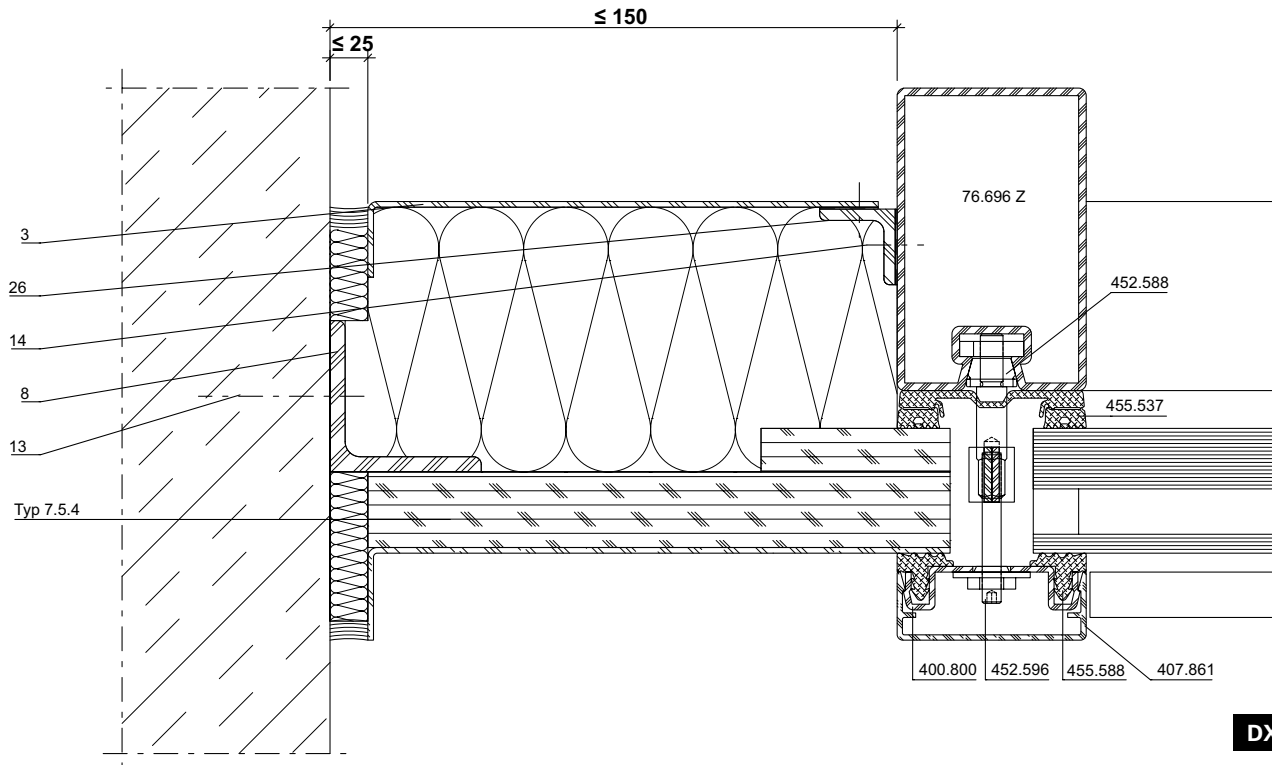

DXF

DWG

51-0501-A-046

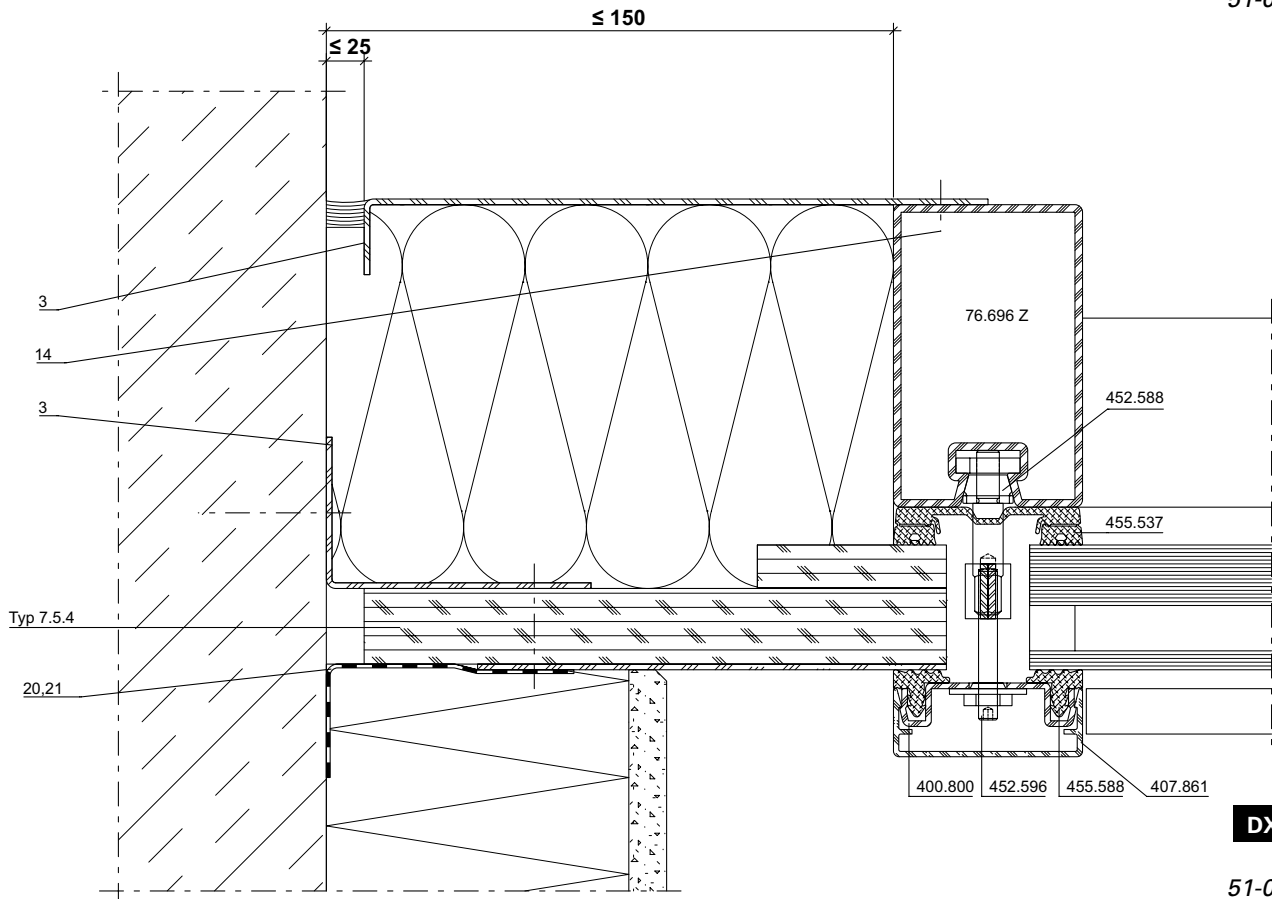

DXF

DWG

51-0501-A-047

Anschlüsse am Bau im Masstab 1:2
Raccords au mur à l'échelle 1:2
Attachment to structure on scale 1:2

VISS Fire EI30 Fassade/Trennwand
VISS Fire EI30 façade/cloison
VISS Fire EI30 façade/partition wall

Wandanschluss

Raccordement au mur

Wall attachment

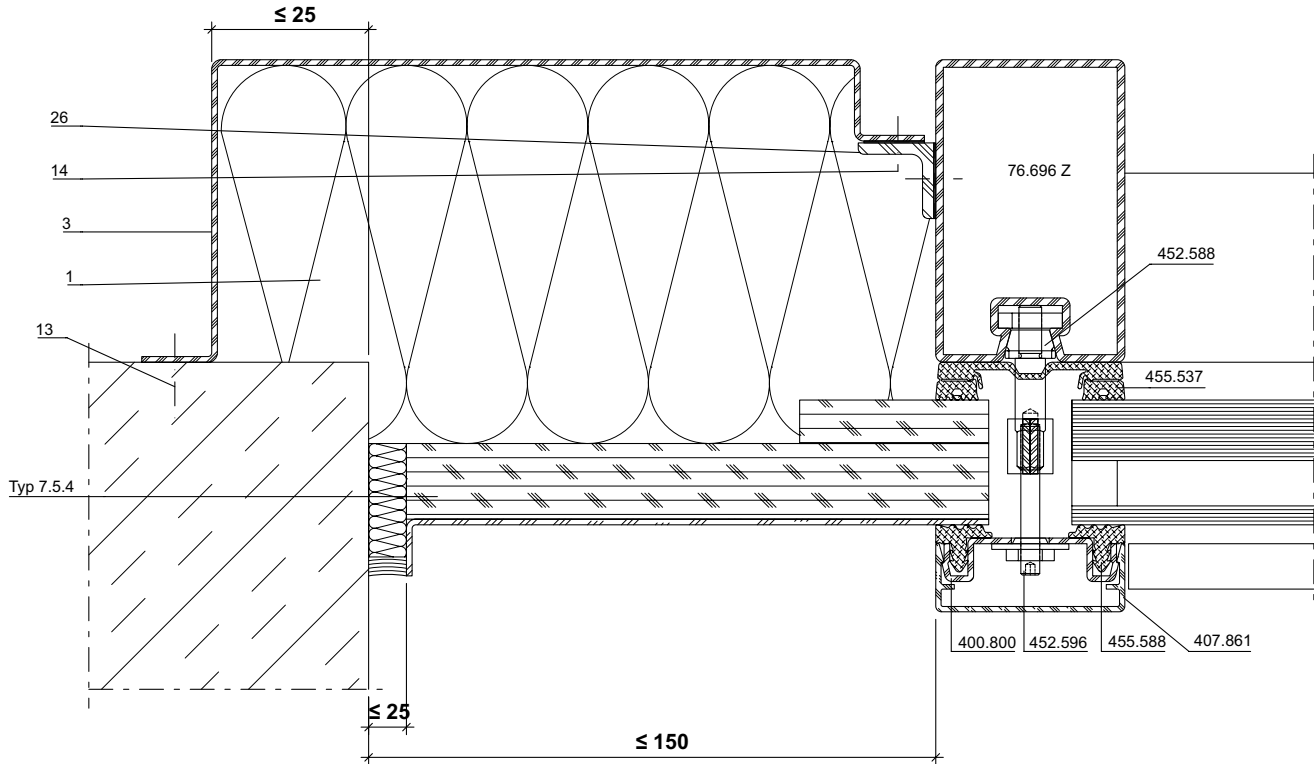

DXF DWG

51-0501-A-048

Wandanschluss

Raccordement au mur

Wall attachment

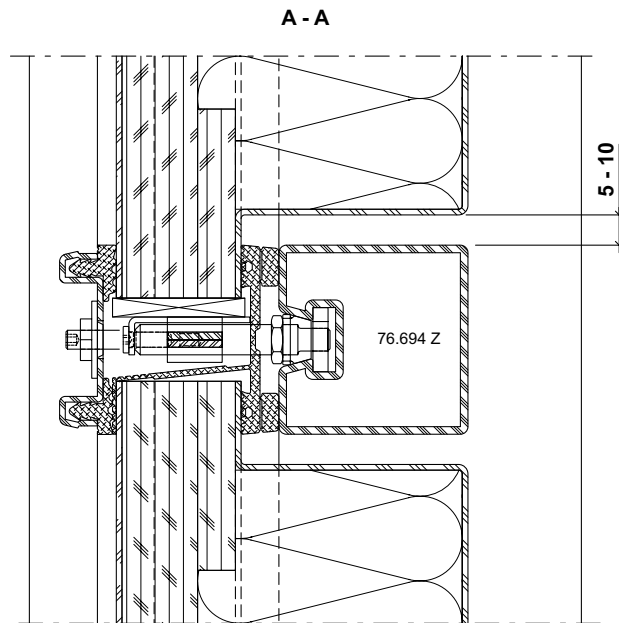
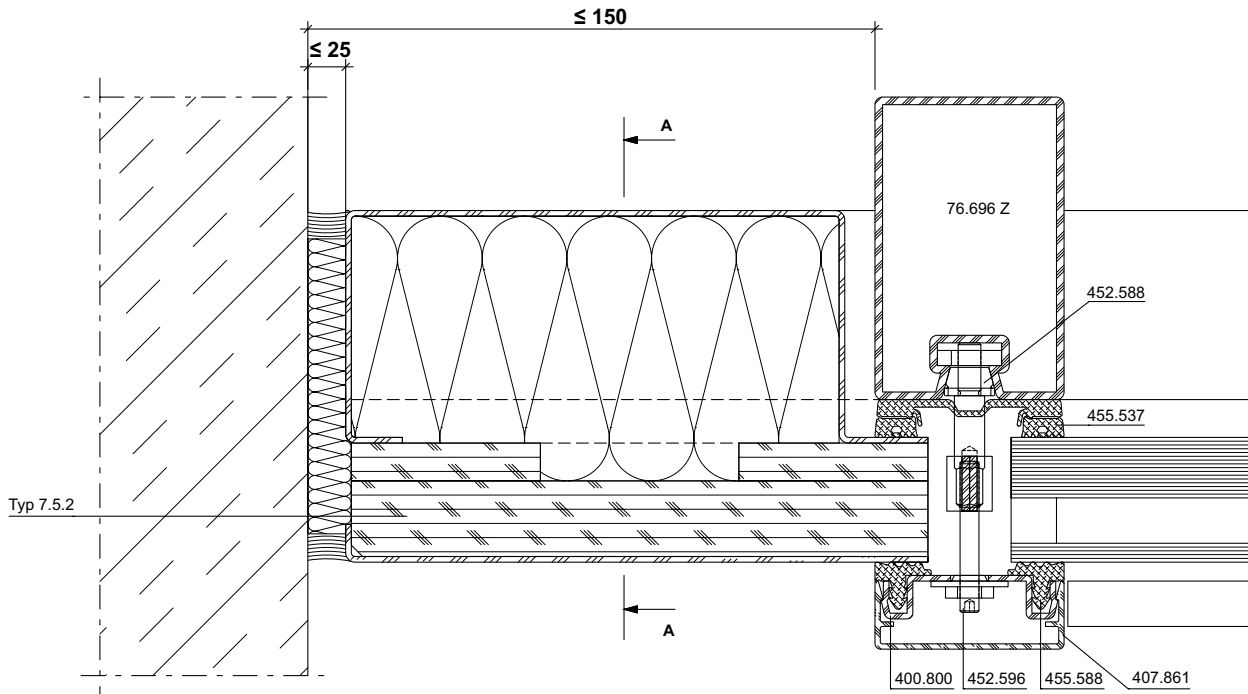

DXF DWG

51-0501-A-049

Wandanschluss

Raccordement au mur

Wall attachment

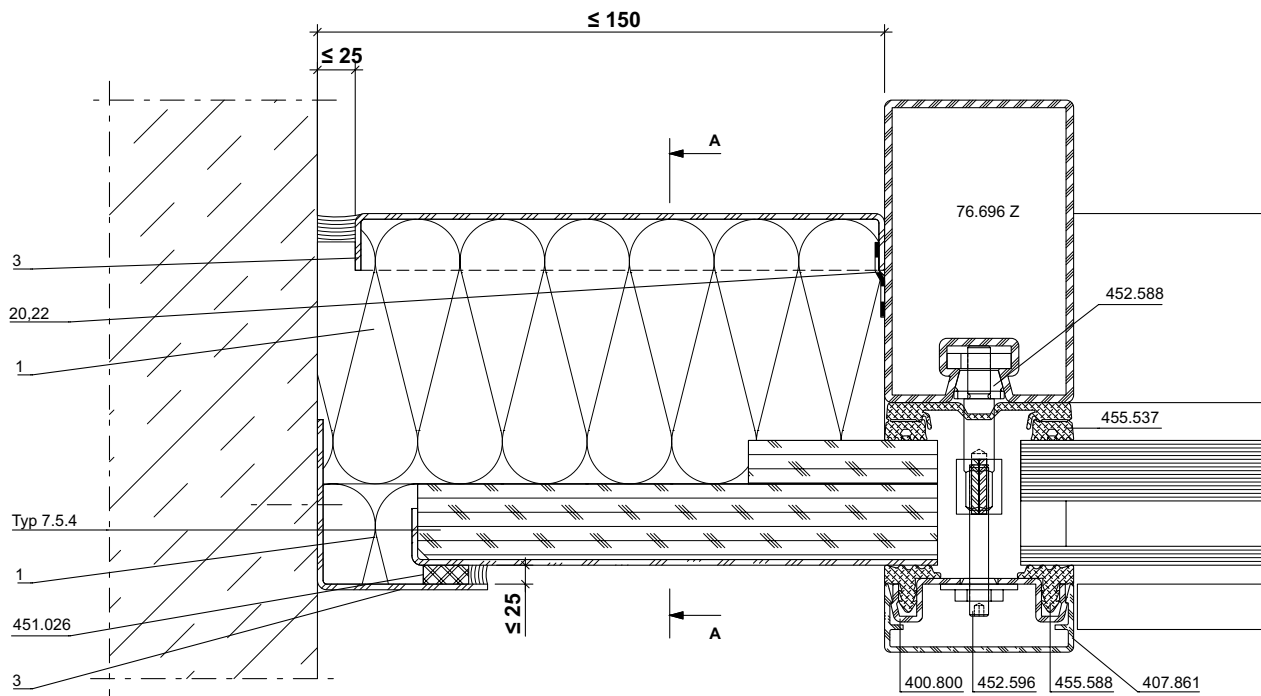

A - A

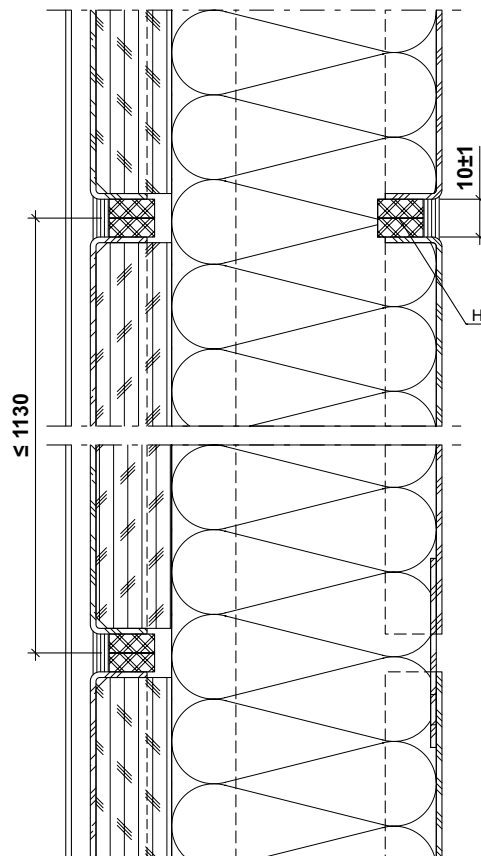

DXF DWG

51-0501-A-051

Wandanschluss

Raccordement au mur

Wall attachment

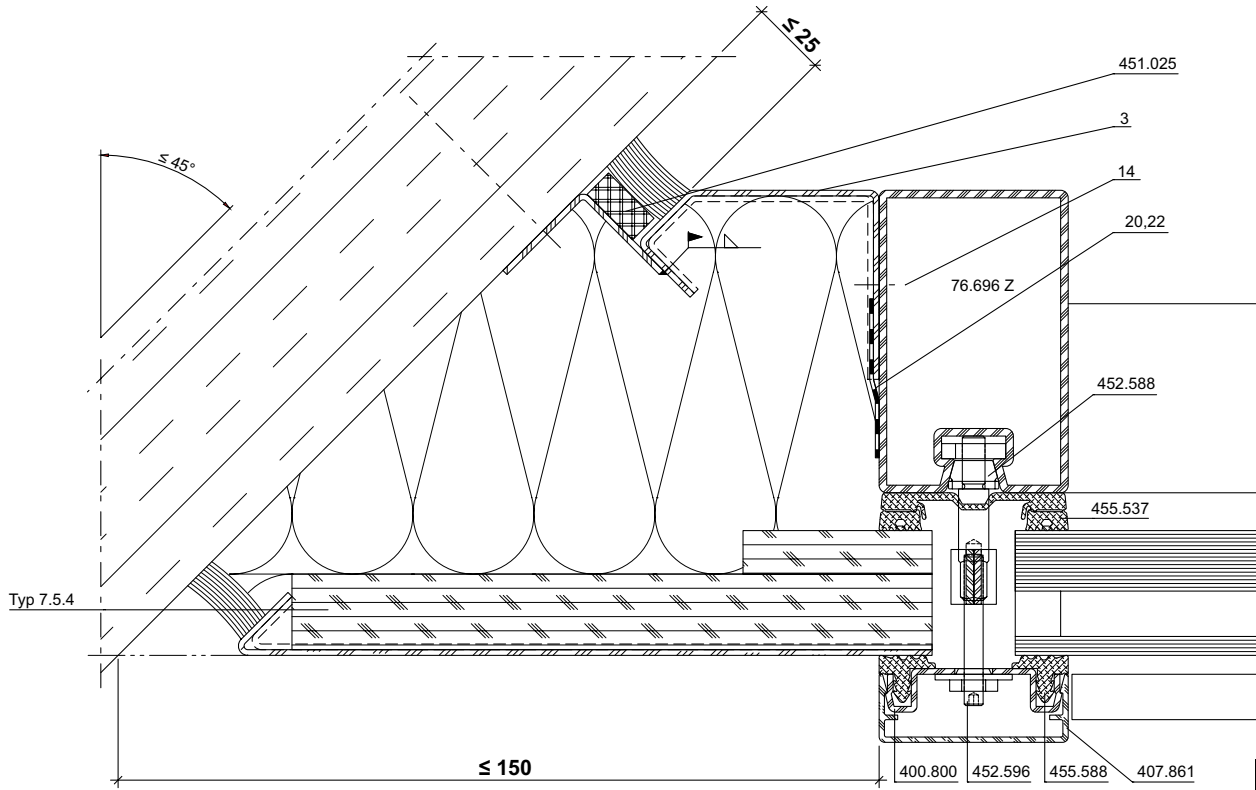

DXF DWG

51-0501-A-053

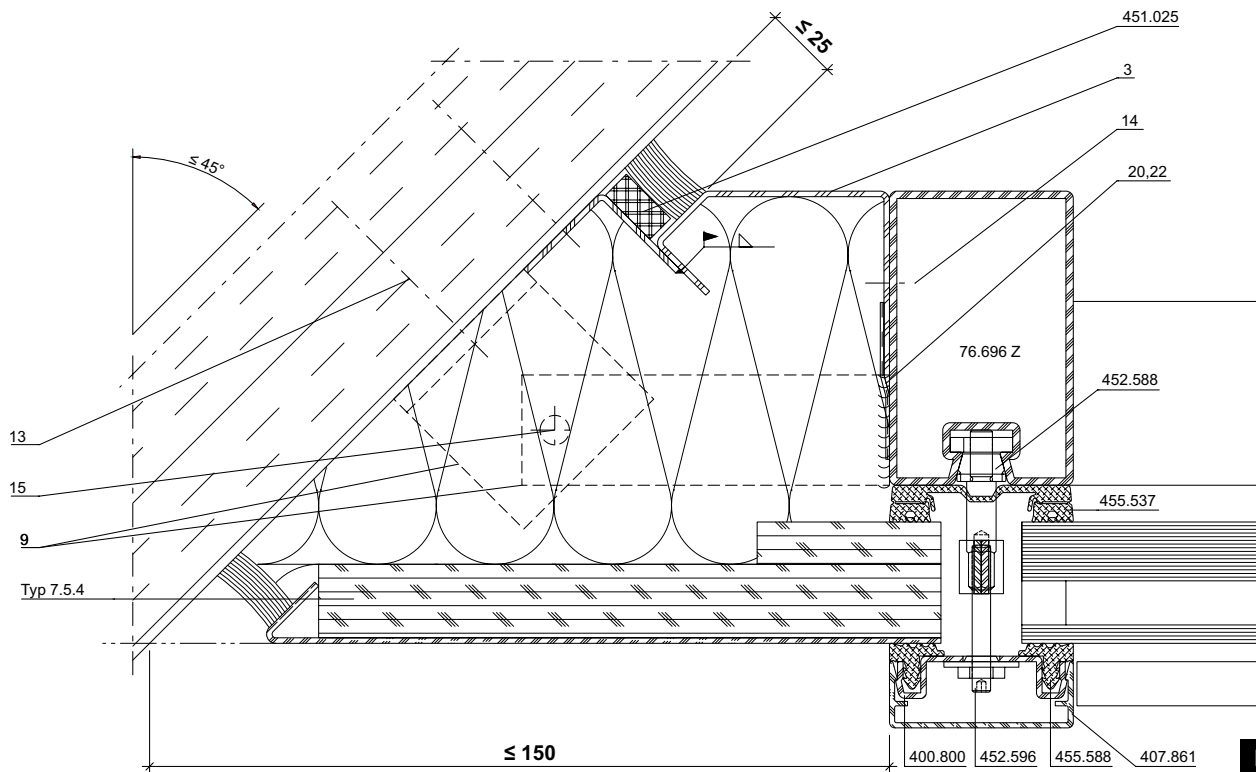

DXF DWG

51-0501-A-054

Wandanschluss

Raccordement au mur

Wall attachment

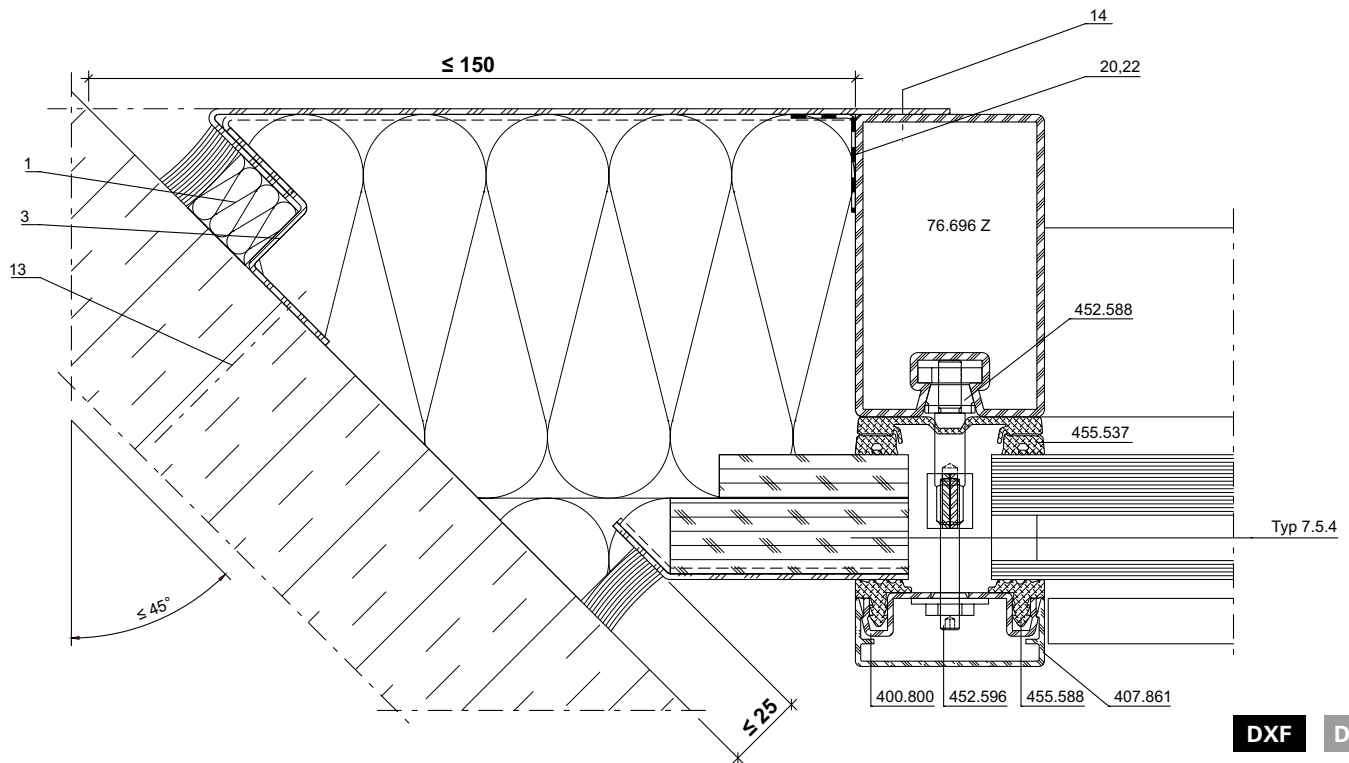

DXF DWG

51-0501-A-055

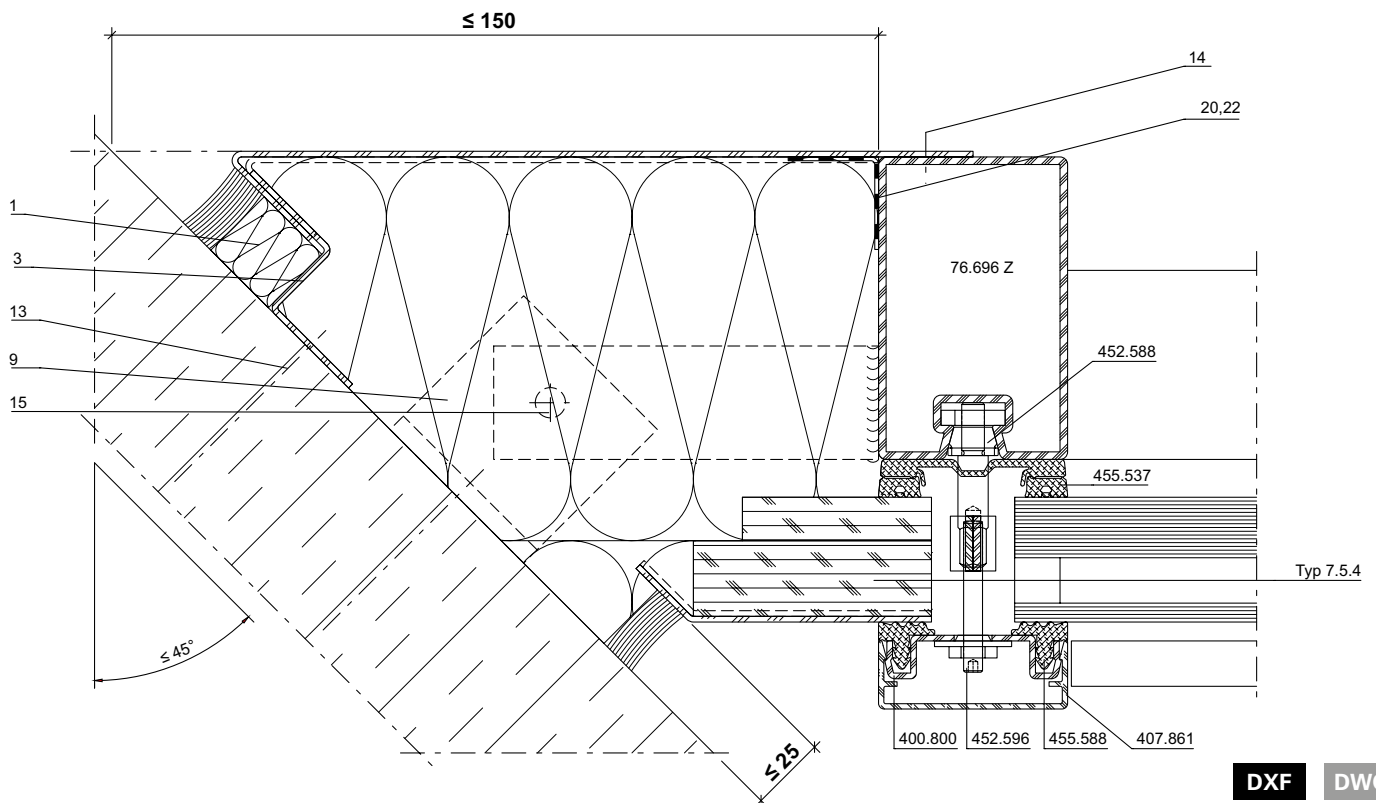

DXF DWG

51-0501-A-056

Anschlüsse am Bau im Massstab 1:2
Raccords au mur à l'échelle 1:2
Attachment to structure on scale 1:2

VISS Fire EI30 Fassade/Trennwand
VISS Fire EI30 façade/cloison
VISS Fire EI30 façade/partition wall

Wandanschluss vorge setzt

Raccordement au mur intermédiaire

Forward-mounted wall attachment

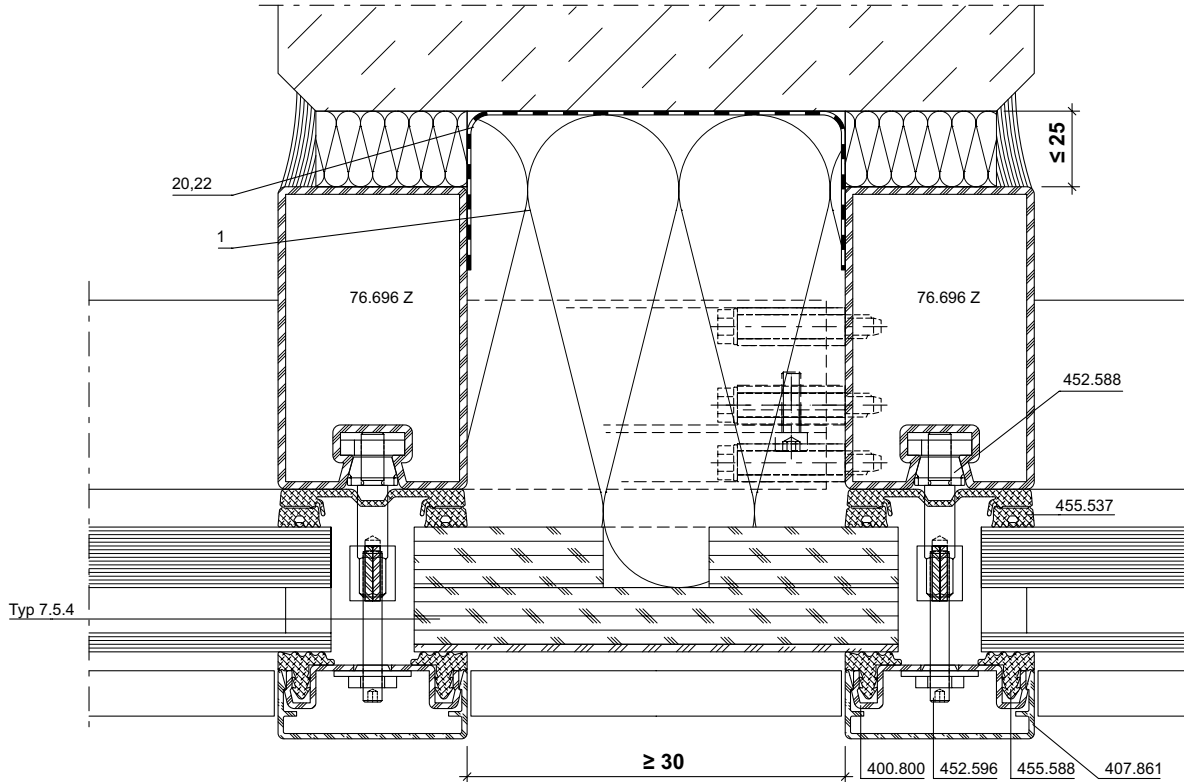

DXF DWG

51-0501-A-057

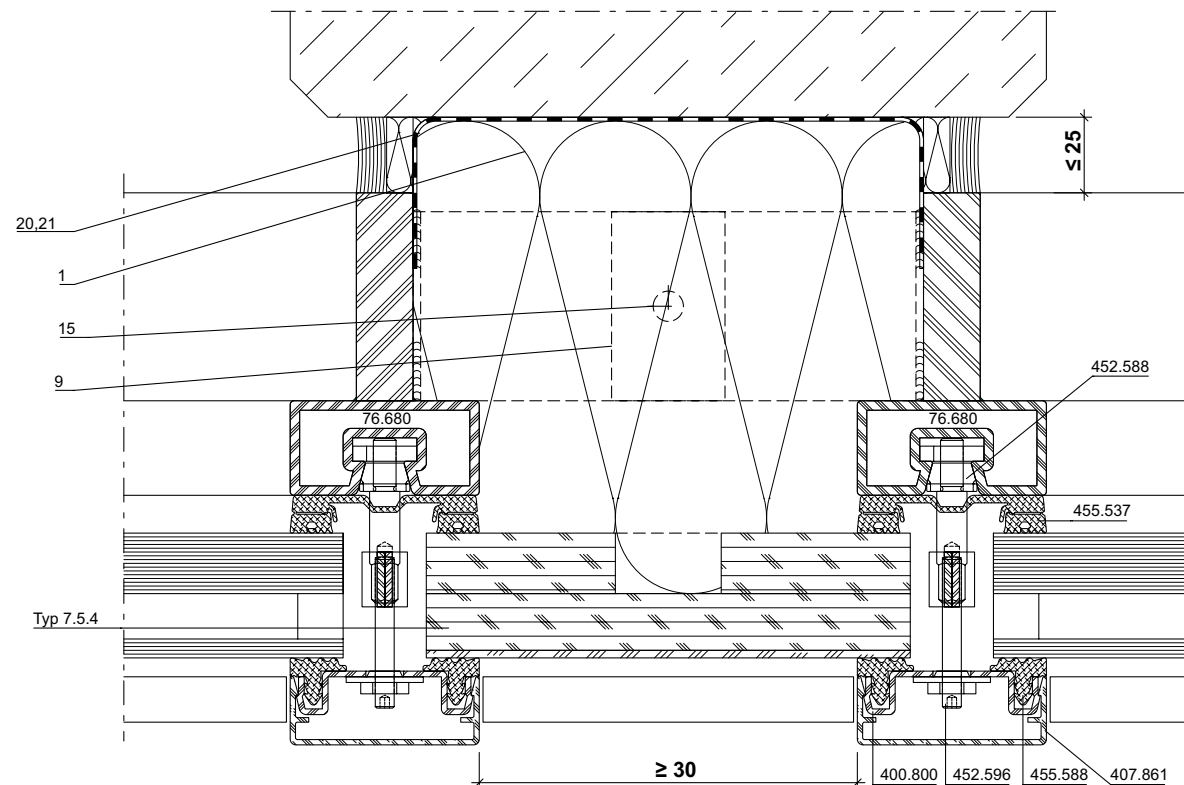

DXF DWG

51-0501-A-058

Wandanschluss vorgesetzt

Raccordement au mur intermédiaire

Forward-mounted wall attachment

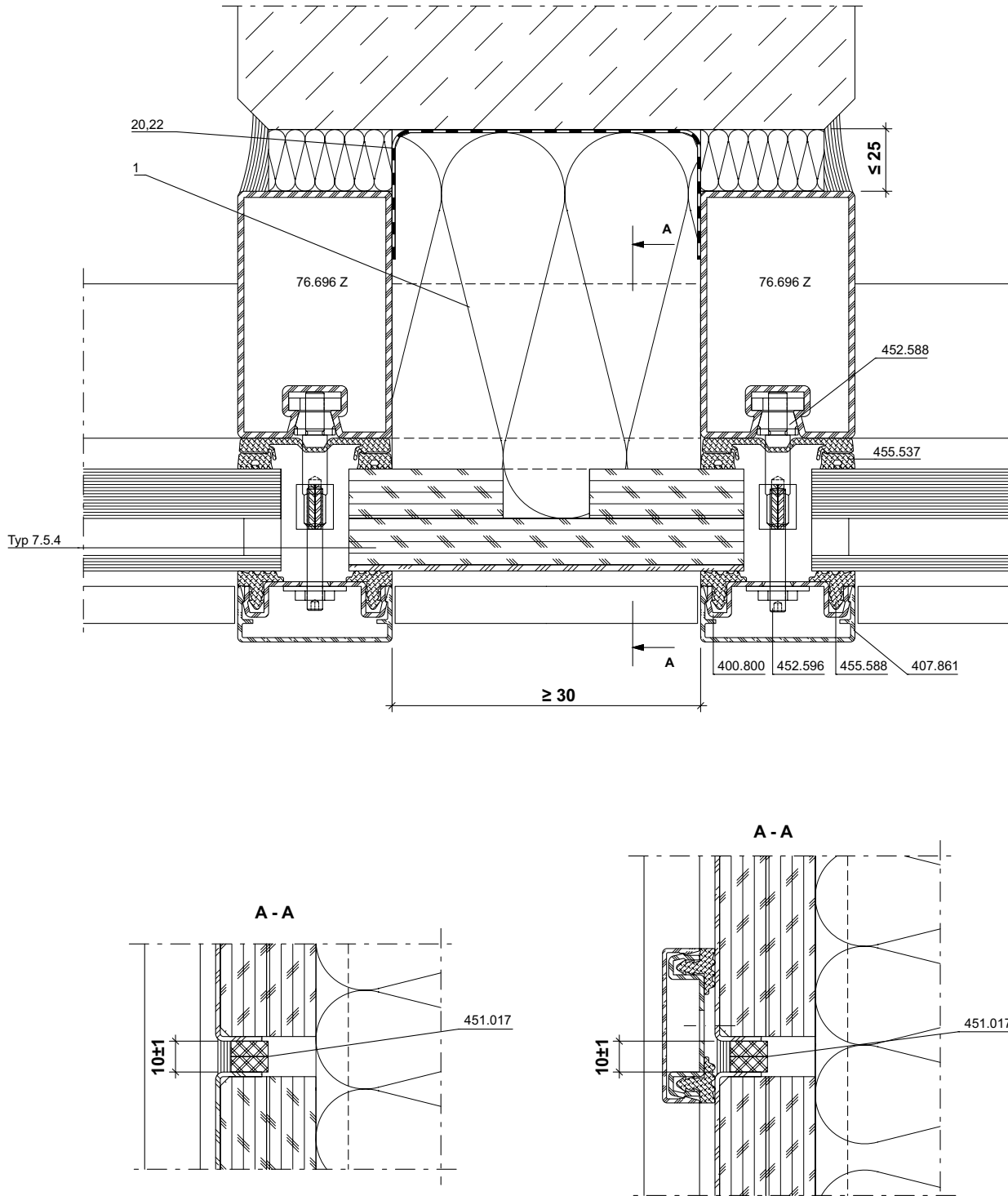

DXF DWG

51-0501-A-059

Anschlüsse am Bau im Massstab 1:2
Raccords au mur à l'échelle 1:2
Attachment to structure on scale 1:2

VISS Fire EI30 Fassade/Trennwand
VISS Fire EI30 façade/cloison
VISS Fire EI30 façade/partition wall

Wandanschluss vorge setzt

Raccordement au mur intermédiaire

Forward-mounted wall attachment

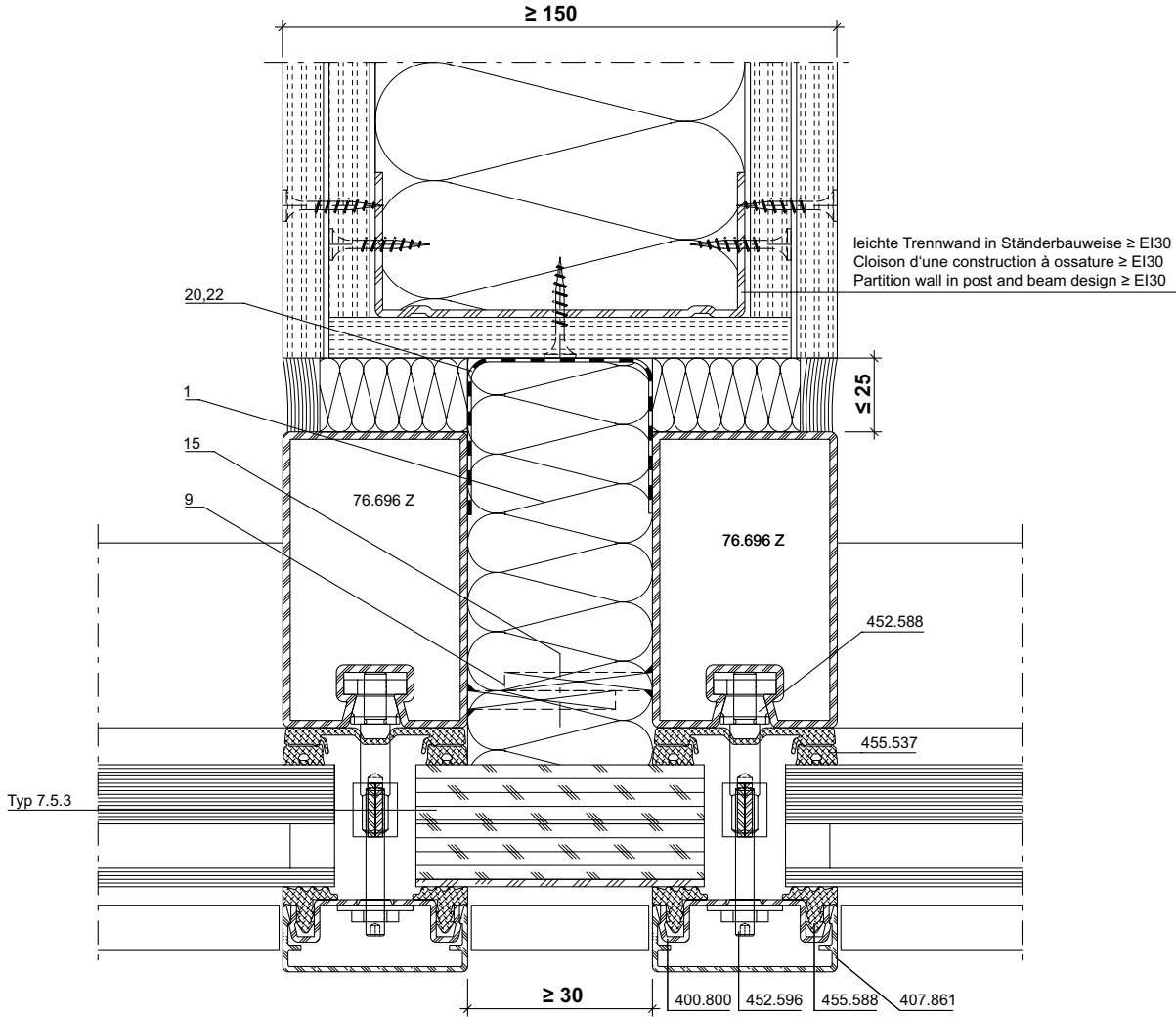

DXF DWG

51-0501-A-060

Anschlüsse am Bau im Massstab 1:2
Raccords au mur à l'échelle 1:2
Attachment to structure on scale 1:2

VISS Fire EI30 Fassade/Trennwand
VISS Fire EI30 façade/cloison
VISS Fire EI30 façade/partition wall

Wandanschluss vorgesetzt

Raccordement au mur intermédiaire

Forward-mounted wall attachment

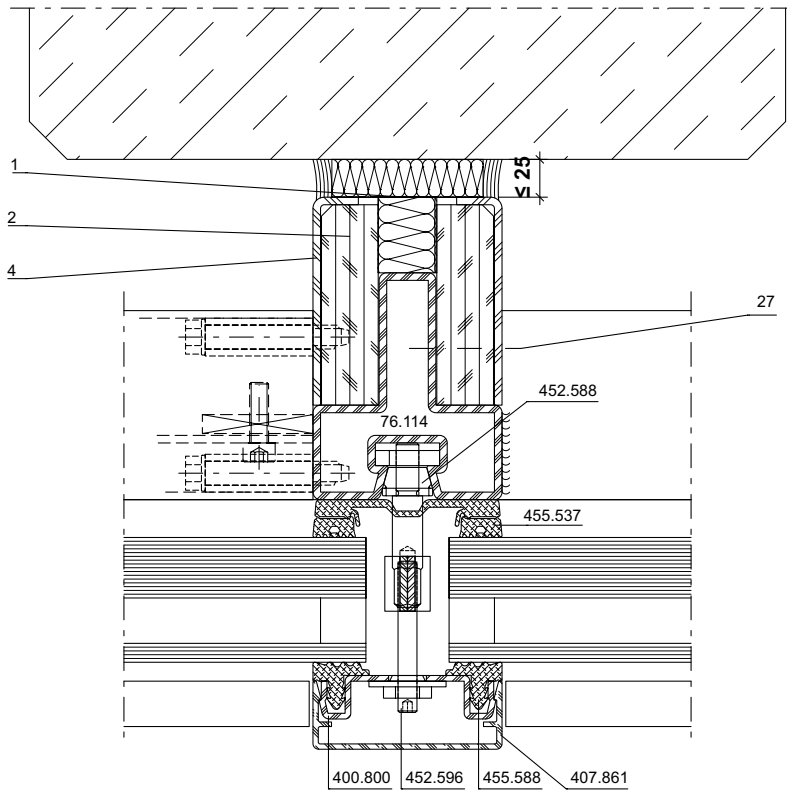

DXF DWG

51-0501-A-061

Anschlüsse am Bau im Massstab 1:2
Raccords au mur à l'échelle 1:2
Attachment to structure on scale 1:2

VISS Fire EI30 Fassade/Trennwand
VISS Fire EI30 façade/cloison
VISS Fire EI30 façade/partition wall

Wandanschluss

Raccordement au mur

Wall attachment

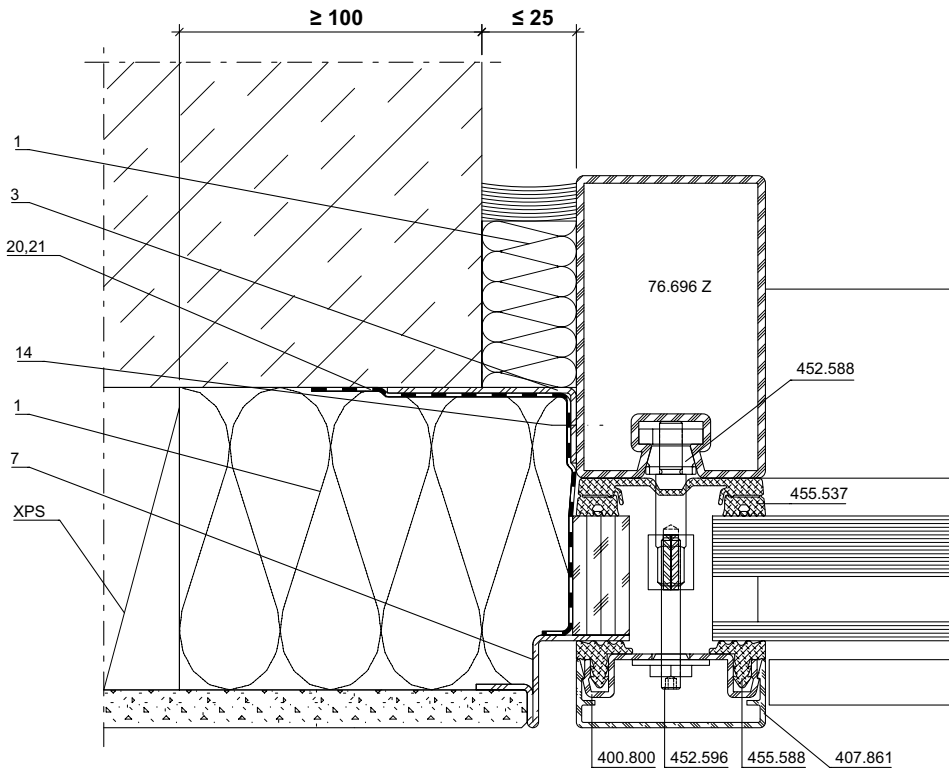

DXF **DWG**

51-0501-A-069

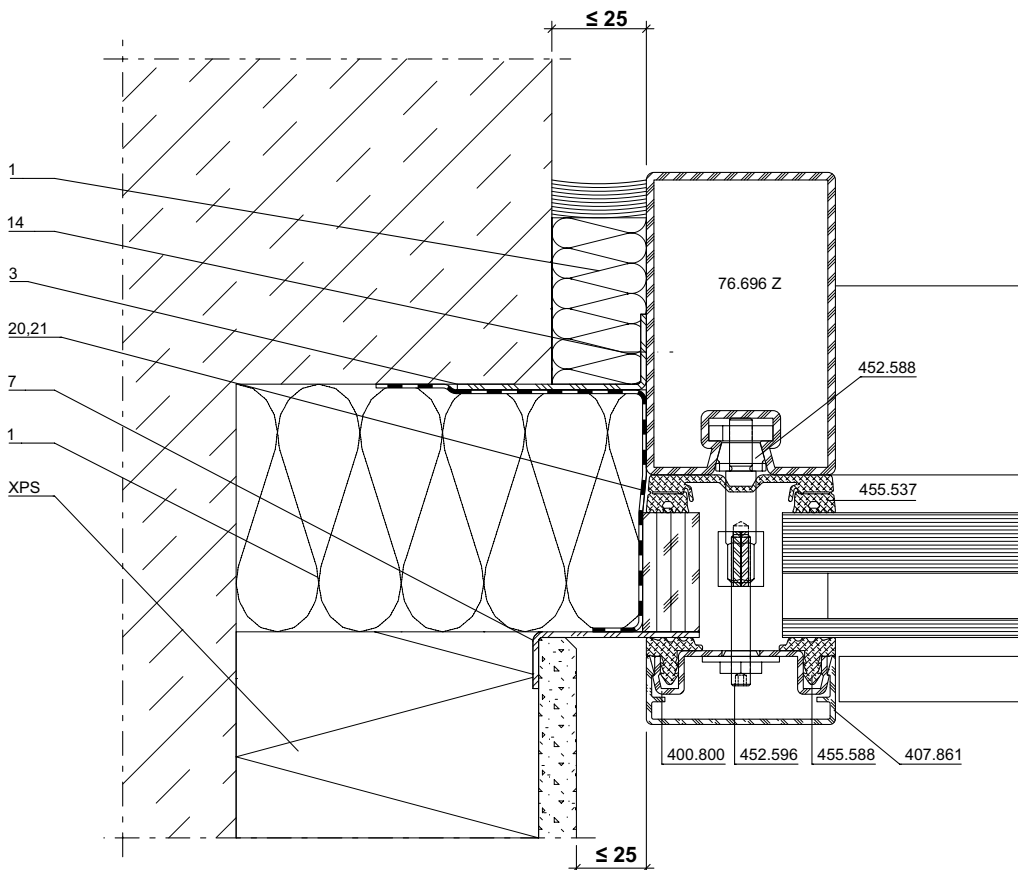

DXF **DWG**

51-0501-A-070

Bodenanschluss

Fixation au sol

Floor attachment

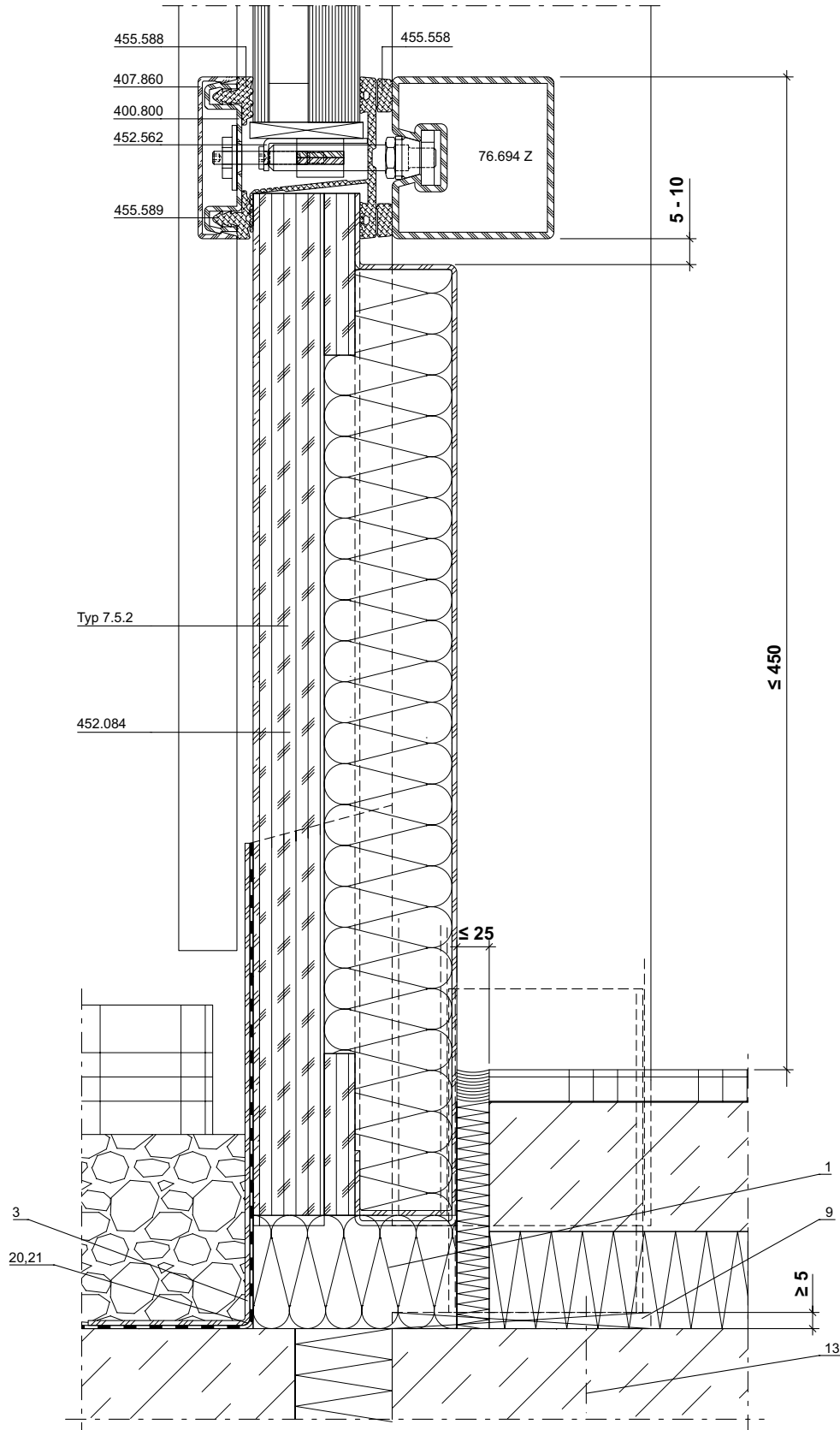

DXF DWG

51-0501-A-068

Konstruktionsdetails im Masstab 1:2
Détails de construction à l'échelle 1:2
Construction details on scale 1:2

VISS Fire EI30 Fassade/Trennwand
VISS Fire EI30 façade/cloison
VISS Fire EI30 façade/partition wall

Einsatzelement
Janisol 2 EI30 Türe

Élément de remplissage
Porte Janisol 2 EI30

Infill element
Janisol 2 EI30 door

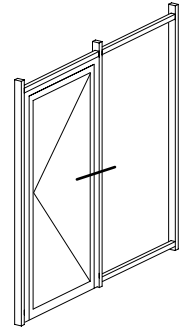
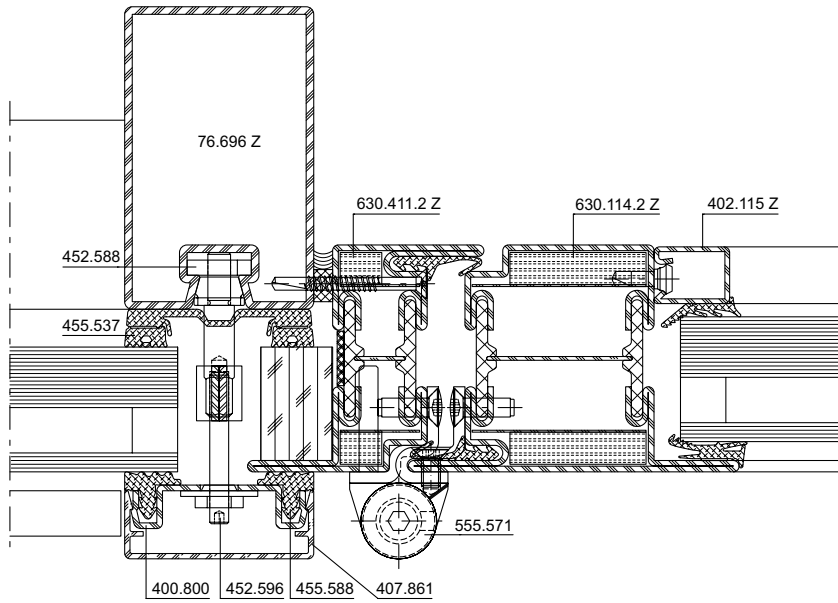

DXF **DWG**

51-0501-K-022

Türeinbau und Abmessungen
siehe nationale Zulassungen
und Klassifizierungsbericht
13-003089-PR01.

Montage et dimensions de la porte,
voir les approbations nationales
et le rapport de classification
13-003089-PR01.

Door installations and dimensions,
see national approvals and
classification report 13-003089-PR01.

Glaseinstand

Prise en feu

Glass edge cover

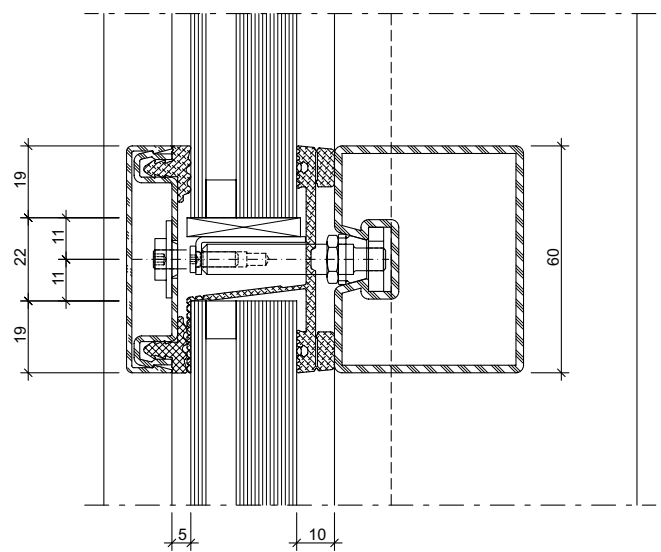
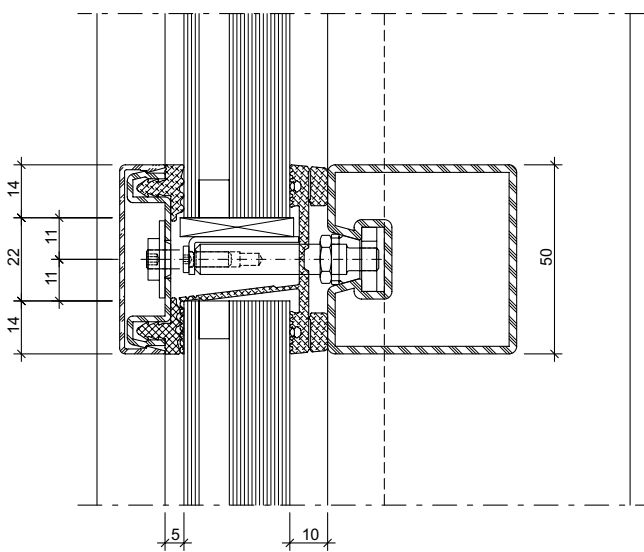
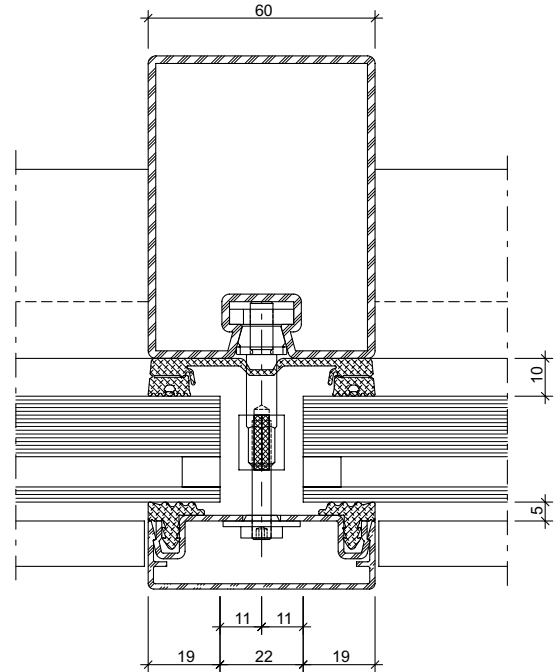
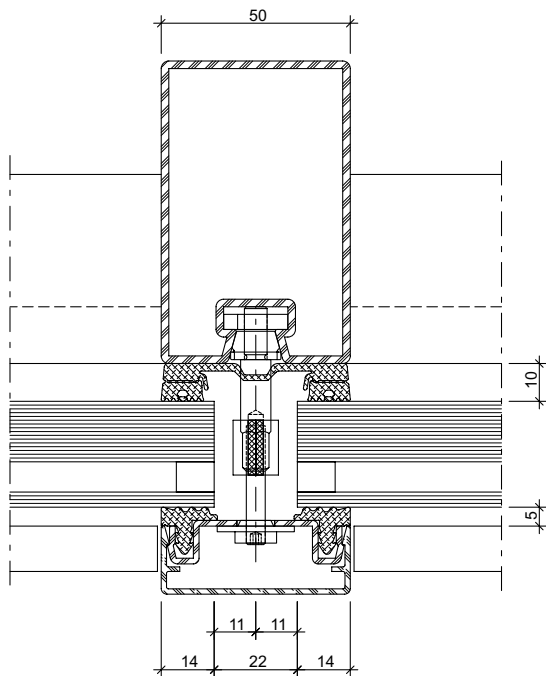

Glaseinstand VISS DV

Prise en feuillure VISS DV

Glass edge cover VISS DV

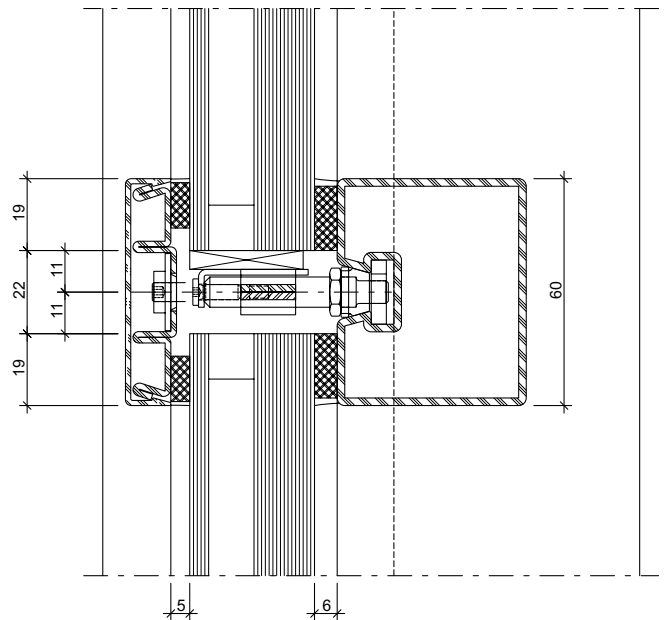
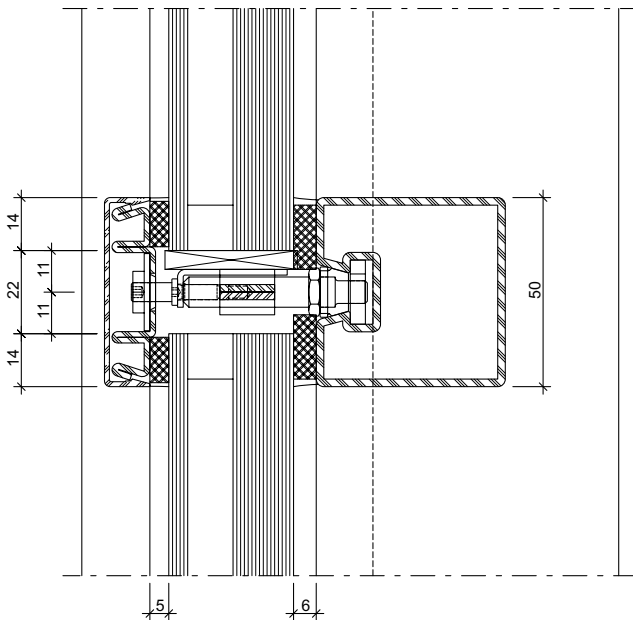
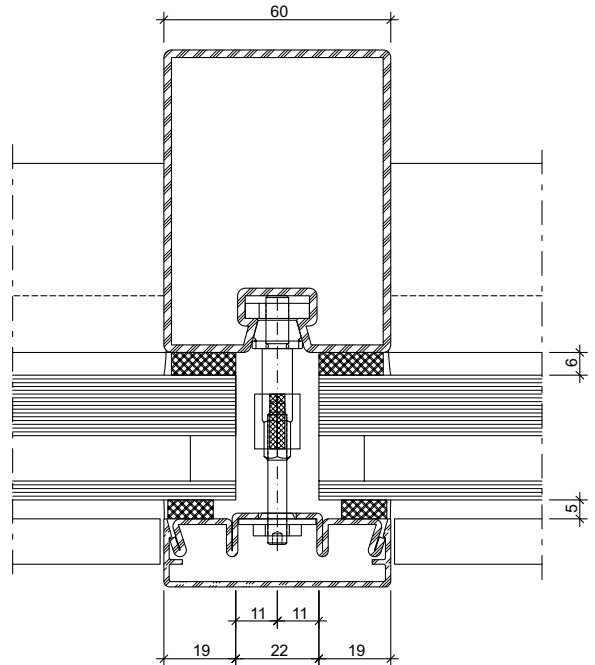
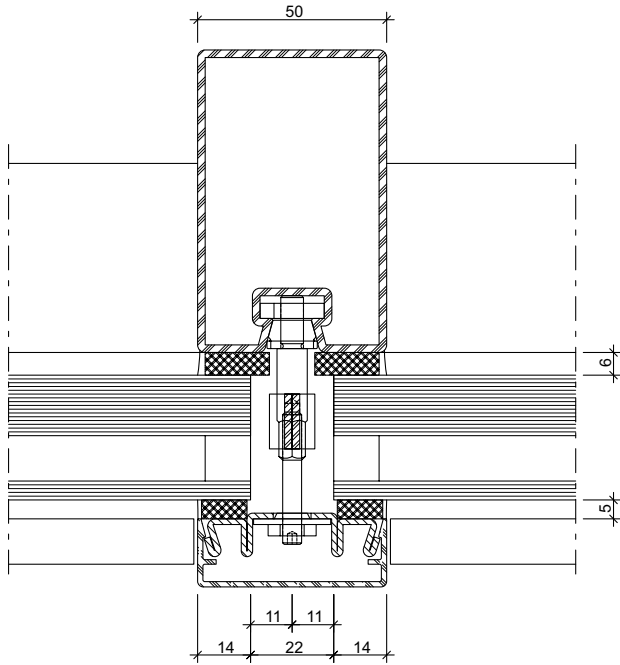

Befestigungsarten

Méthode de fixation

Fastening types

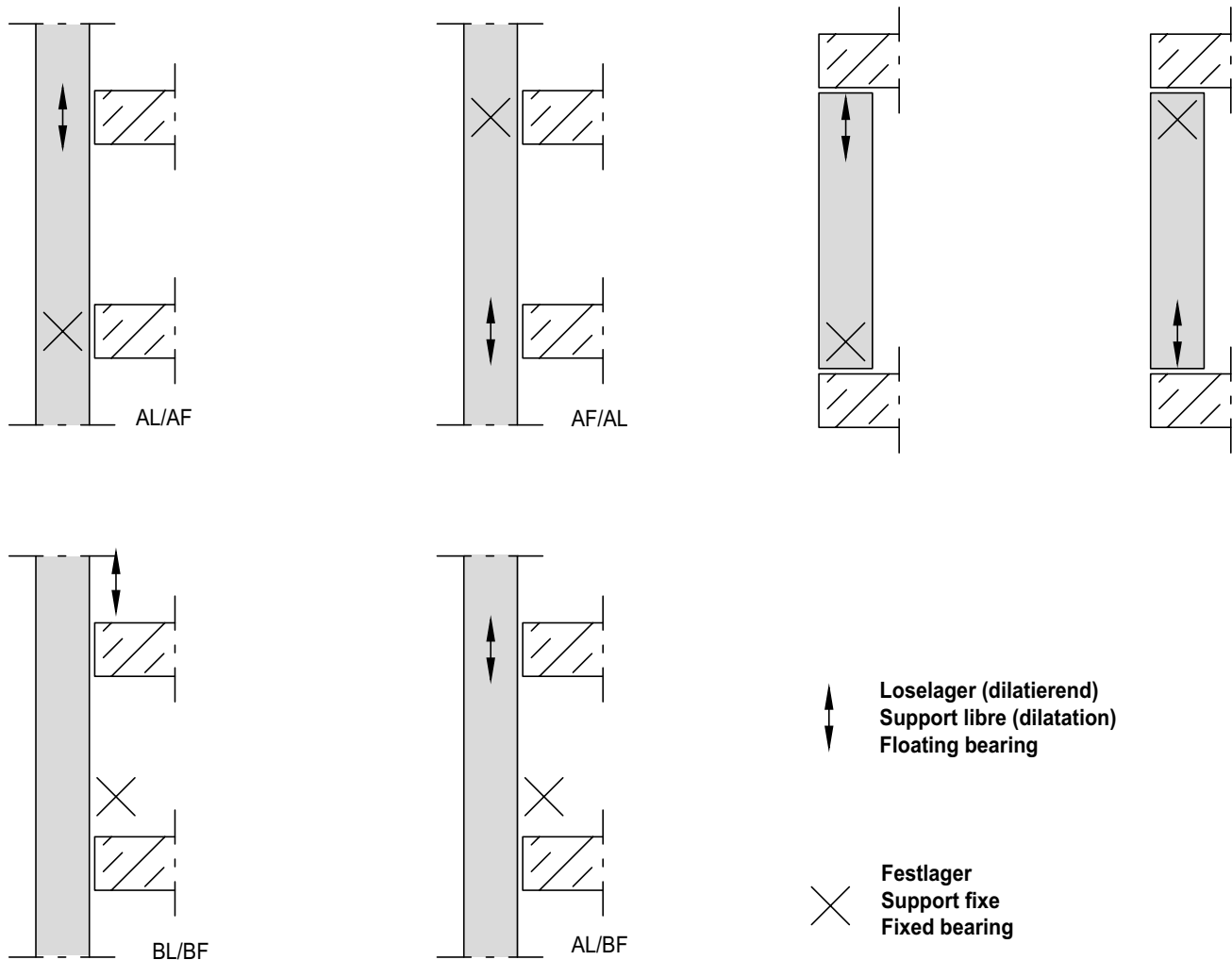

Pfostenausdehnung

Pro 1 m Pfostenhöhe muss 5 mm Ausdehnung ermöglicht werden.

Expansion du montant

Prévoir 5 mm de dilatation par 1 mètre de hauteur de montant.

Mullion expansion

Per 1 m Mullion height must be 5 mm expansion enabled.

**Pfostenbauweise mit
Schwerlast T-Verbinder einhängbar**
452.060-452.063
452.070-452.076

**Méthode de construction modulaire
avec raccord en T charge lourde à
suspendre**
452.060-452.063
452.070-452.076

**Push-on construction with heavy-duty
clip-in connecting spigot**
452.060-452.063
452.070-452.0763

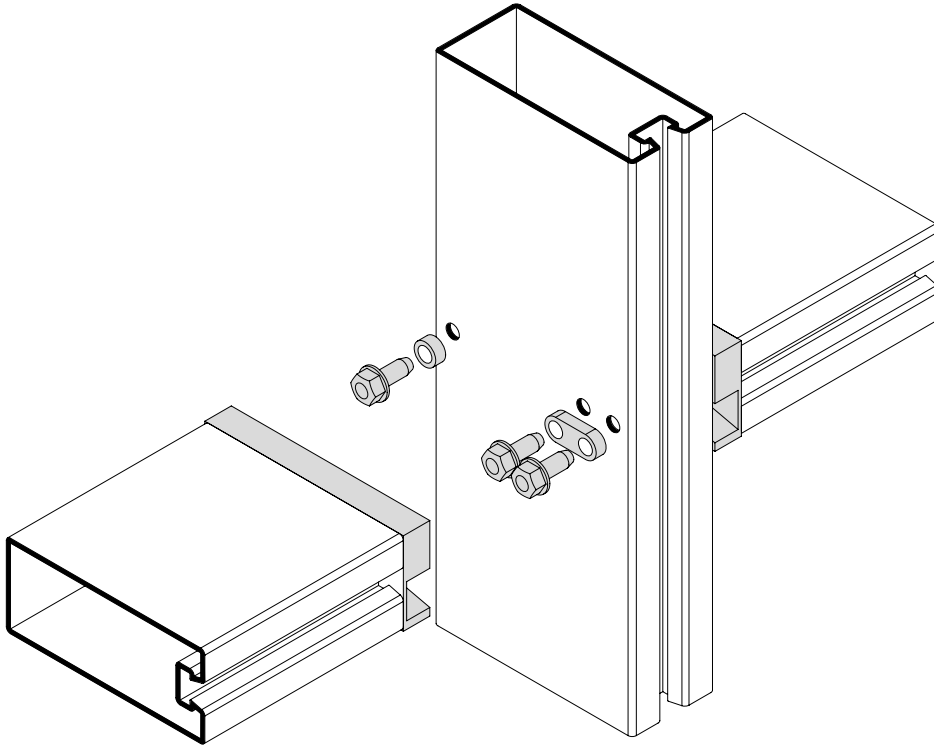

**Steckbauweise mit
Universal T-Verbinder**
452.033 / 452.030

**Méthode de construction
modulaire avec raccord en T universel**
452.033 / 452.030

**Push-on construction
with universal connecting spigot**
452.033 / 452.030

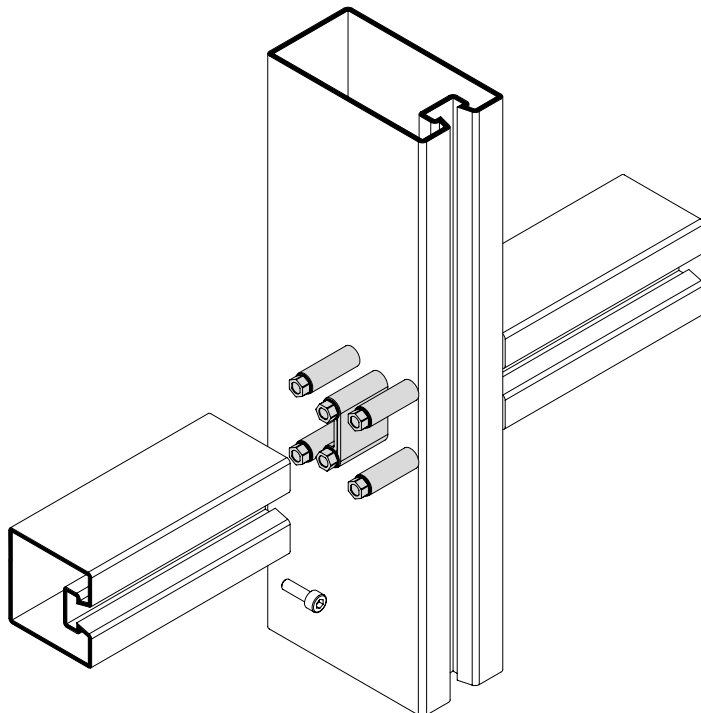

**Steckbauweise mit
Universal T-Verbinder
452.030 / 452.032**

**Méthode de construction
modulaire avec raccord en T universel
452.030 / 452.032**

**Push-on construction
with universal connecting spigot
452.030 / 452.032**

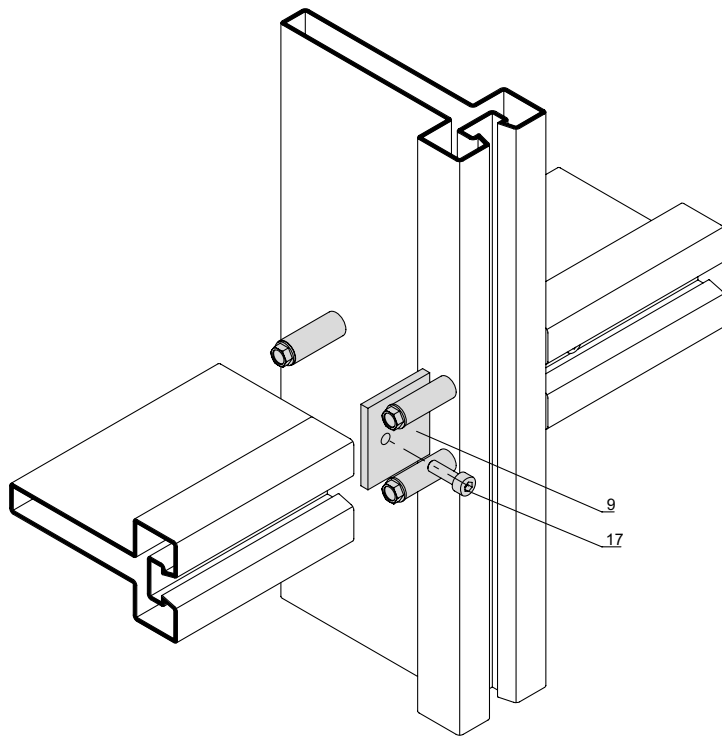

**Steckbauweise mit
Universal T-Verbinder
452.030 und Stahlplatte**

**Méthode de construction
modulaire avec raccord en T universel
452.030 et plaque d'acier**

**Push-on construction
with universal connecting spigot
452.030 and steel plate**

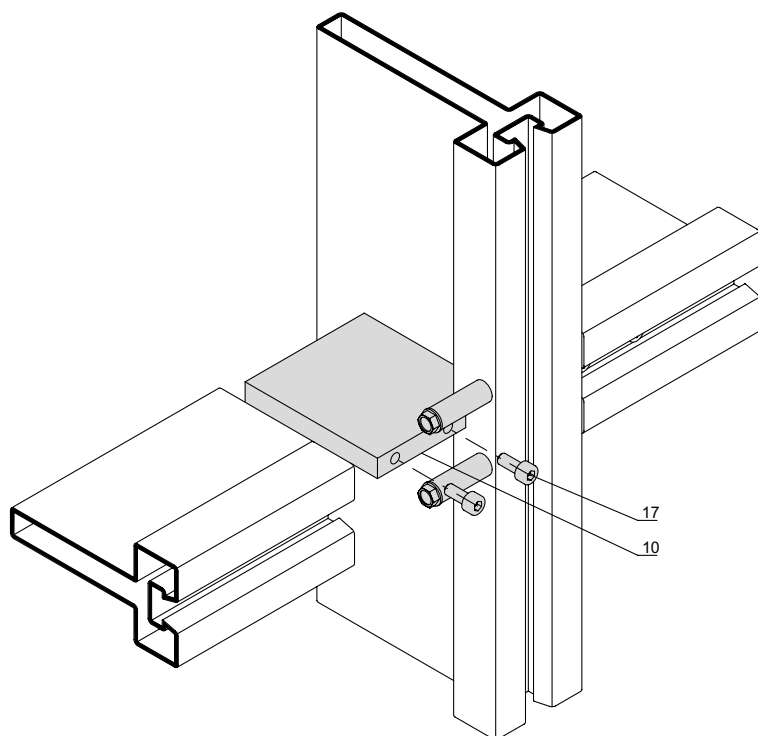

Rahmenbauweise
Riegel geschweisst

Méthode de construction
par éléments traverse soudée

Unitised construction
for welded transom

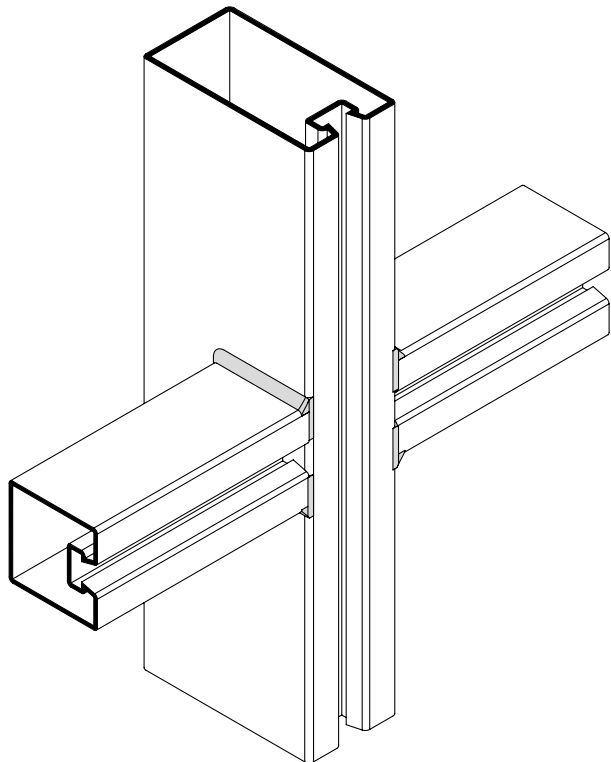

T-Verbinder gesteckt

Raccord en T manchonné

Slide-on connecting spigot

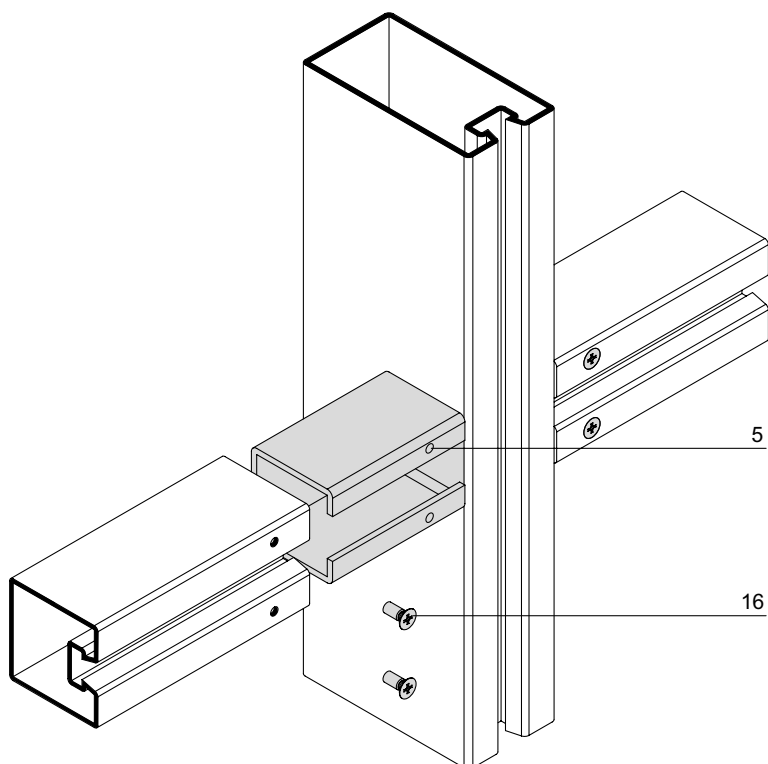

T-Verbinder mit Winkel

Raccord en T avec équerre

connecting spigot with angle

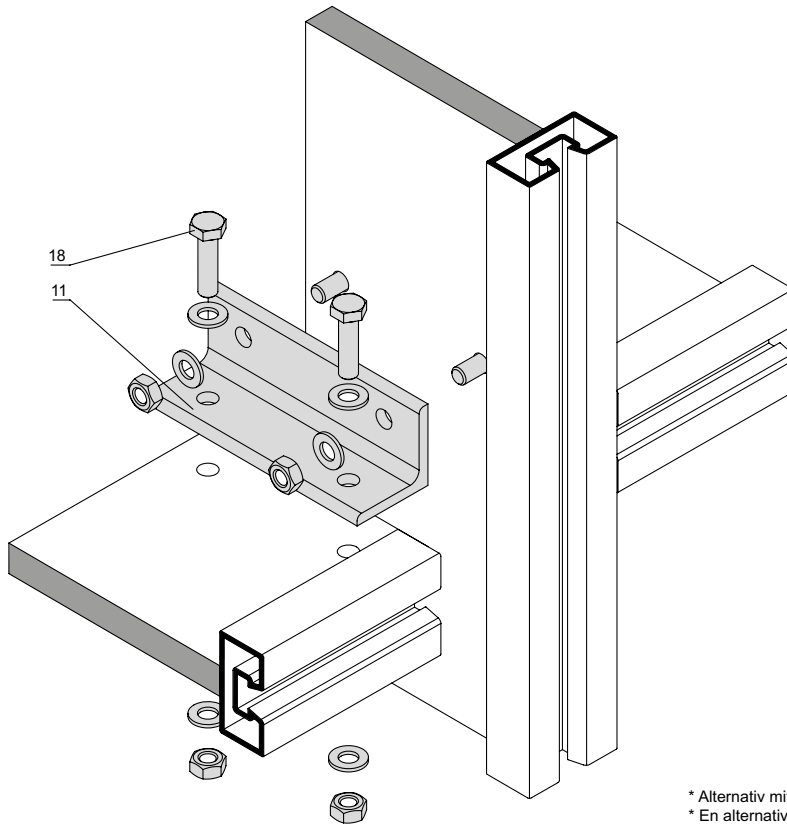

* Alternativ mit Gewinde im Pfosten und Riegel
 * En alternative avec filetage du montant et traverse
 * Alternative with thread at the mullion and transom

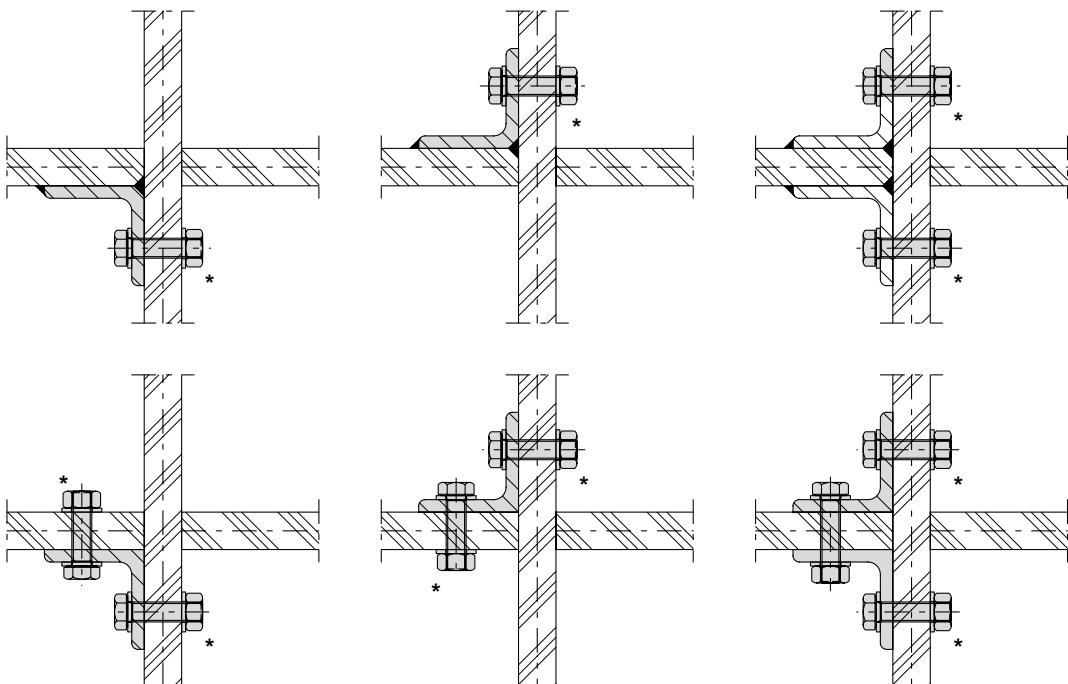

Profilverstärkungen

Renforts de profilés

Profile reinforcement

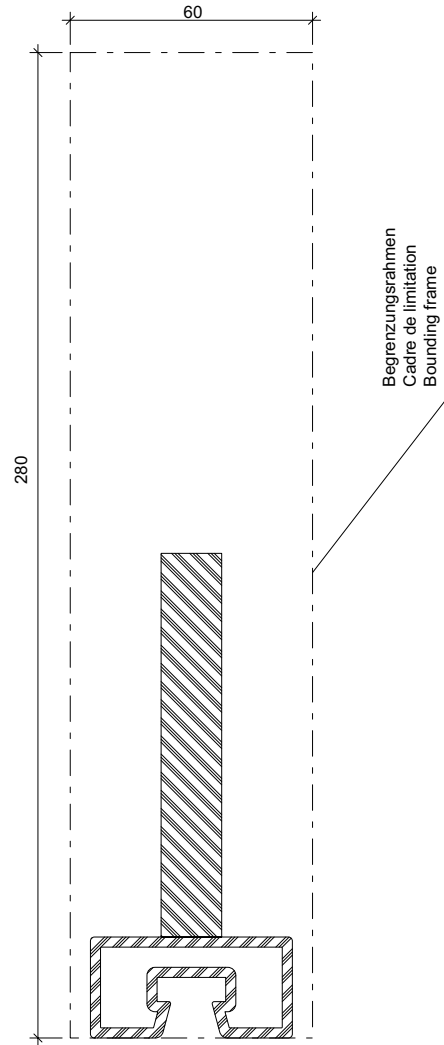
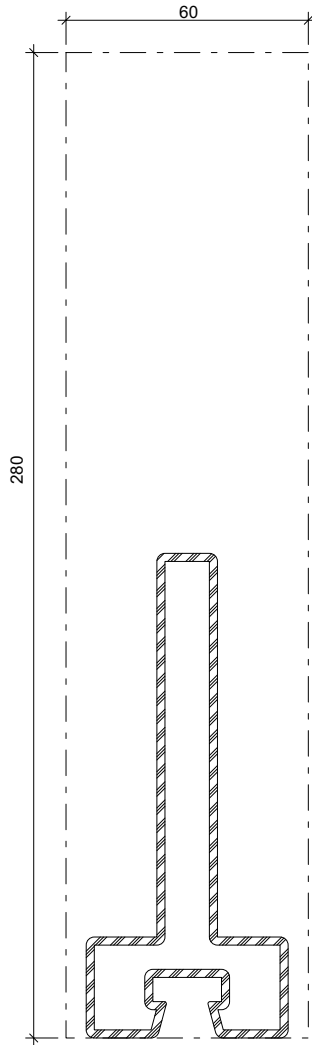
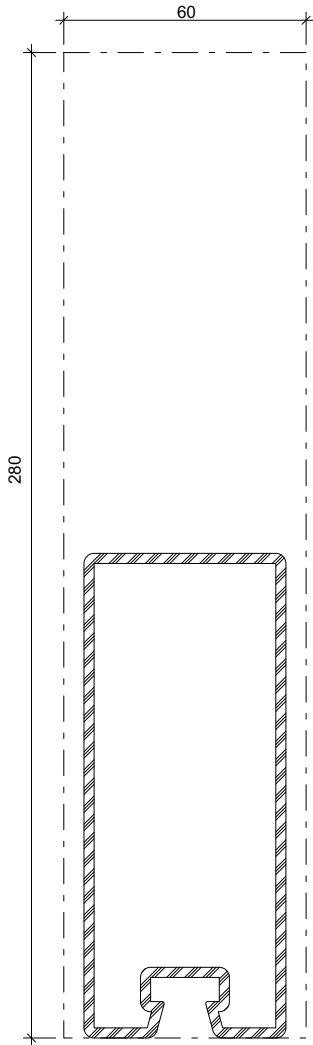

Stahl-Profilverstärkungen bis zu einer Gesamt-Querschnittsfläche von 3144 mm² an jeder Position innerhalb des Begrenzungsrahmens möglich.

Renforts de profilés en acier jusqu'à une section totale de 3144 mm² possibles, inclus à l'intérieur du cadre périphérique 60x280 mm.

Steel-profile reinforcement up to a total cross-section area of 3144 mm² on every position inside of the bounding frame possible.

System-Hinweise

Remarques concernant les systèmes

System instructions

VISS Fire EI30 Fassade/Trennwand

VISS Fire EI30 façade/cloison

VISS Fire EI30 façade/partition wall

VISS 50 mm

U_{cw} -Werte nach EN 10077-2

VISS 50 mm

Valeurs U_{cw} selon EN 10077-2

VISS 50 mm

U_{cw} values according to 10077-2

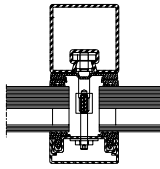
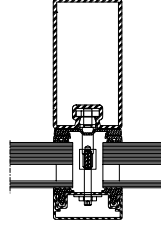
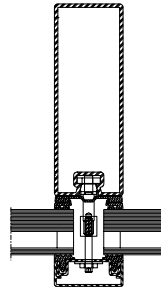
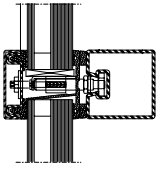
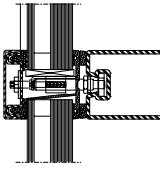
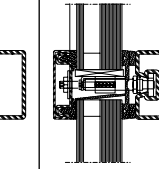
						
Glas Verre Glass	Pfosten 50/50 Montant 50/50 Mullion 50/50	Pfosten 50/95 Montant 50/95 Mullion 50/95	Pfosten 50/140 Montant 50/140 Mullion 50/140	Riegel 50/50 Traverse 50/50 Transom 50/50	Riegel 50/95 Traverse 50/95 Transom 50/95	Riegel 50/140 Traverse 50/140 Transom 50/140
20 mm	1,7 W/m ² K	1,8 W/m ² K	1,8 W/m ² K	1,5 W/m ² K	1,6 W/m ² K	1,6 W/m ² K
30 mm	1,6 W/m ² K	1,6 W/m ² K	1,6 W/m ² K	1,4 W/m ² K	1,4 W/m ² K	1,4 W/m ² K
40 mm	1,5 W/m ² K	1,5 W/m ² K	1,5 W/m ² K	1,3 W/m ² K	1,3 W/m ² K	1,3 W/m ² K
50 mm	1,4 W/m ² K	1,4 W/m ² K	1,5 W/m ² K	1,2 W/m ² K	1,2 W/m ² K	1,2 W/m ² K
60 mm	1,4 W/m ² K	1,4 W/m ² K	1,4 W/m ² K	1,1 W/m ² K	1,2 W/m ² K	1,2 W/m ² K
70 mm	1,3 W/m ² K	1,3 W/m ² K	1,4 W/m ² K	1,1 W/m ² K	1,1 W/m ² K	1,1 W/m ² K

Der Einfluss der Schraubenbefestigung in Höhe von 0.14 W/m²K ist berücksichtigt.

L'influence de la fixation à vis de 0.14 W/m²K est prise en compte.

The 0.14 W/m²K influence of the screw fixing is taken into account.

System-Hinweise

Remarques concernant les systèmes

System instructions

VISS Fire EI30 Fassade/Trennwand

VISS Fire EI30 façade/cloison

VISS Fire EI30 façade/partition wall

VISS 60 mm

U_{cw}-Werte nach EN 10077-2

VISS 60 mm

Valeurs U_{cw} selon EN 10077-2

VISS 60 mm

U_{cw} values according to 10077-2

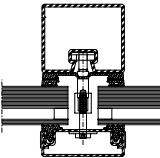
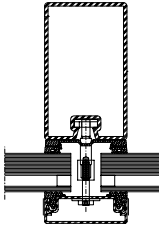
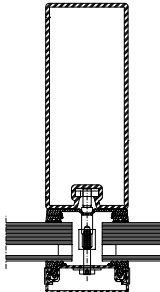
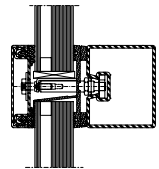
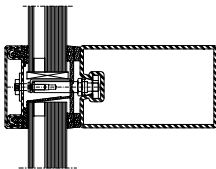
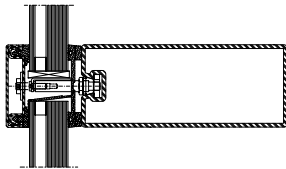
						
Glas	Pfosten 60/50	Pfosten 60/100	Pfosten 60/150	Riegel 60/50	Riegel 60/100	Riegel 60/150
Verre	Montant 60/50	Montant 60/100	Montant 60/150	Traverse 60/50	Traverse 60/100	Traverse 60/150
Glass	Mullion 60/50	Mullion 60/100	Mullion 60/150	Transom 60/50	Transom 60/100	Transom 60/150
20 mm	1,6 W/m ² K	1,7 W/m ² K	1,7 W/m ² K	1,4 W/m ² K	1,5 W/m ² K	1,5 W/m ² K
30 mm	1,5 W/m ² K	1,5 W/m ² K	1,5 W/m ² K	1,3 W/m ² K	1,3 W/m ² K	1,3 W/m ² K
40 mm	1,3 W/m ² K	1,4 W/m ² K	1,4 W/m ² K	1,1 W/m ² K	1,2 W/m ² K	1,2 W/m ² K
50 mm	1,2 W/m ² K	1,3 W/m ² K	1,3 W/m ² K	1,1 W/m ² K	1,1 W/m ² K	1,1 W/m ² K
60 mm	1,2 W/m ² K	1,2 W/m ² K	1,2 W/m ² K	1,0 W/m ² K	1,0 W/m ² K	1,0 W/m ² K
70 mm	1,1 W/m ² K	1,2 W/m ² K	1,2 W/m ² K	0,96 W/m ² K	0,97 W/m ² K	0,98 W/m ² K

Der Einfluss der Schraubenbefestigung in Höhe von 0.14 W/m²K ist berücksichtigt.

L'influence de la fixation à vis de 0.14 W/m²K est prise en compte.

The 0.14 W/m²K influence of the screw fixing is taken into account.

Änderungen / Ergänzungen
Modifications / Compléments
Modifications / Supplements

Jansen Stahlssysteme
Systèmes en acier Jansen
Jansen Steel Systems

Lieferprogramm
VISS Fire EI30

Code A = Änderungen
Code E = Ergänzungen

Version 06/2020
Artikelnummer K1192248

Programme de livraison
VISS Fire EI30

Code A = Modifications
Code E = Compléments

Version 06/2020
Numéro d'article K1192248

Sales range
VISS Fire EI30

Code A = Modifications
Code E = Supplements

Version 06/2020
Item number K1192248

Seite	Code	Datum	Erläuterung
Page	Code	Date	Explication
Page	Code	Date	Explanation

Jansen AG

Steel Systems
Industriestrasse 34
9463 Oberriet
Schweiz
jansen.com

JANSEN