



Innovations

Jansen solutions for BAU 2025

JANSEN

Table of Contents



Element	VISS Fire Facade EI30 RC2/3	Page 4 + 5
Design	Fire Protection Facade with burglary protection	



Element	Janisol C4 EI120	Page 6 + 7
Design	Partition Wall Element	



Element	VISS Roof Glazing	Page 8 + 9
Design	VISS Roof Standard, Semi SG and Fire EI30	



Element	Janisol Arte 66	Page 10 + 11
Design	Lift and Slide Door	

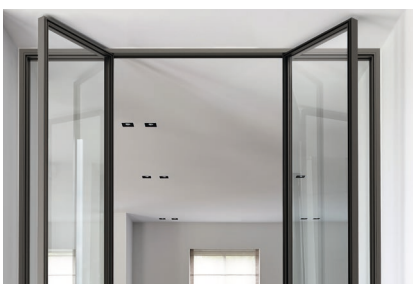

Element	Jansen Art'15 In collaboration with Piet Boon	Page 12 + 13
Design	Door and Partition Wall	



Element	Janisol Arte 2.0 Plus	Page 14 + 15
Design	RC2 Door	



Element	Janisol Arte	Page 16 + 17
Design	Panorama Sliding Door	

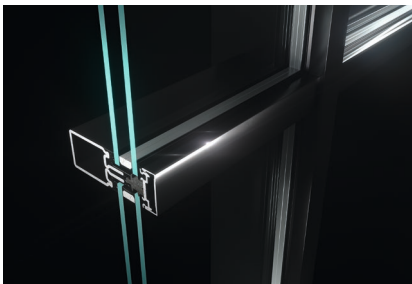

Element	Jansen Tecline 40	Page 18 + 19
Design	Facade	



Element	Jansen Finline	Page 20 + 21
Design	Vertical Pivot Window	

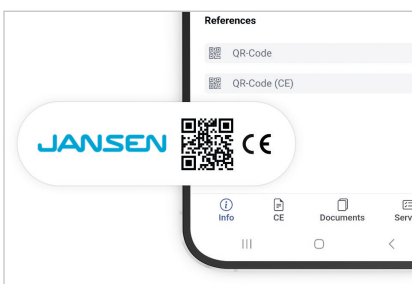

Element	Jansen SimplyTag	Page 20 + 23
Design	Digital Application	



VISS Fire Facade EI30 RC2/3

VISS Fire EI30 RC2/3 Multifunctional Facade

In times of increasing urbanisation and the associated tightening of building safety requirements, facades must be capable of meeting these requirements. Jansen is the only manufacturer to offer the option of producing a facade up to 5 metres high that fulfils the requirements of both the EI30 and the RC2/3 ratings.

The Jansen VISS Fire Facade EI30 RC2/3 therefore offers a higher standard of security while at the same time contributing to cost efficiency through simplified building management, as fewer different systems need to be integrated and maintained.



Design

The multifunctional VISS Fire Facade EI30 RC2/3 is particularly suitable for use in areas at risk of burglary, within shopping centres for example, as here fire protection and burglary protection are often required at the same time. The security components are invisible to the observer. This enables connection with a VISS standard facade without visual restriction. Glass element dimensions of up to W × H 1400 mm × 3000 mm or 3000 mm × 1400 mm allow a clear view to the outside. Tests have been carried out with glazing units produced by Pilkington.



The VISS Fire Facade in the EI30 RC2/3 combination will be available as a partition wall solution **from March 2025** and as an external application with the necessary approvals during the course of 2025.





VISS Roof Glazing

Standard, Semi SG, and VISS Fire roof EI30

Roof glazing combining safety and design

With VISS roof glazing, roofs can be made permeable to light, even when fire protection is required. This makes VISS roof glazing particularly suitable for public buildings, where a high incidence of daylight is desired while simultaneously meeting high fire protection requirements.

Thanks to ongoing updates, the various versions of VISS roof glazing units can be consistently used for roof pitches ranging from 0° in indoor areas, or 7° in outdoor areas, up to 80°.

Face widths of 50 mm and 60 mm are available. The Semi SG solution offers architects an even more sophisticated look.

All VISS roof systems can be used to realise pitched roofs, hipped roofs, pyramids, saw-tooth roofs, or pitched glazing.

VISS roof glazing addresses the issue of sustainability with the basic EPD values of the VISS facade. Energy efficiency is ensured by glass panel thicknesses of up to 70 mm, which enable very good thermal insulation.

VISS roof glazing units are **available as a system solution.**

VISS Roof Standard

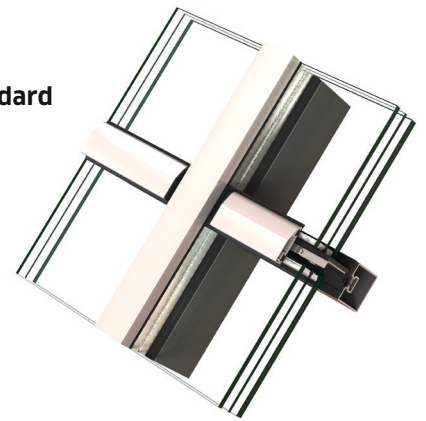

VISS Roof Semi SG

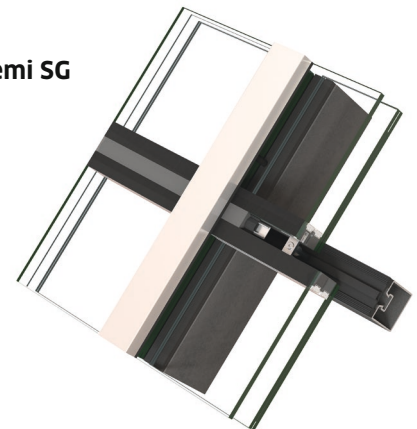

VISS Fire Roof EI30

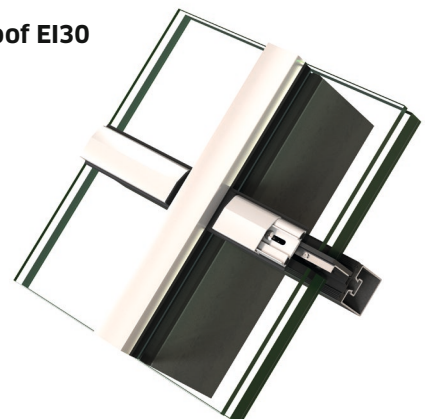

NEW

Janisol Arte 66 Lift and Slide Door

Delicate and smooth-running lift and slide door with various opening options and barrier-free threshold

Standard threshold solution:

Scheme A

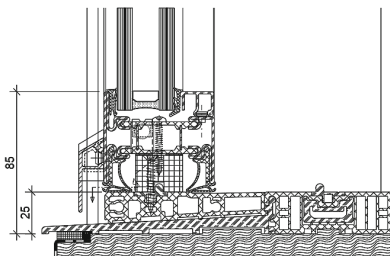
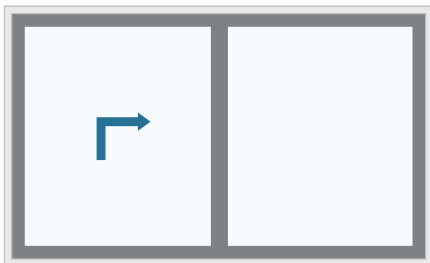

Scheme A with XL fixed panel

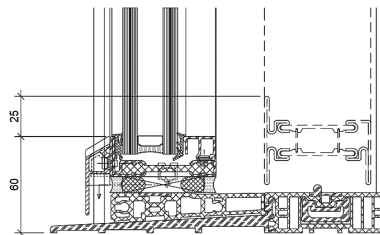

For the first time at BAU 2025, a lift and slide door from the Janisol Arte 66 system will be on show, consisting of a door leaf and fixed panel with even narrower frame face widths now possible.

The Janisol Arte 66 lift and slide door is an innovative, individually configurable element with very slim profile views and highly thermally insulated profiles. Opening schemes A and C are available for the market launch, i.e. either two-part with one sliding door leaf, or four-part with two sliding leaves. With a maximum leaf weight of 400 kg and a maximum leaf size of W × H 3000 mm × 2600 mm (Scheme A), large openings can be created. With a face width of just 55 mm in the centre section, an unobstructed view is guaranteed. The matching threshold is prefabricated to size by Jansen and supplied according to the desired options.

Glass panel thicknesses of up to 53 mm enable the use of insulated glass, which ensures a comfortable indoor climate and makes a significant contribution to the energy efficiency of a building. Various threshold options, including a zero threshold, round off the diverse range of options of the lift and slide door. The lockable version of the element offers additional security.

The basic EPD of the Janisol Arte 66 system demonstrates that the lift and slide door is also sustainable.

The Janisol Arte 66 lift and slide door is expected to be available from the **3rd quarter of 2025** as a project solution.





NEW

Jansen Art'15

Door and partition wall

in collaboration with Designstudio Piet Boon

Design perfected

Jansen has entered into a collaboration with Piet Boon, an internationally renowned architecture and design studio based in the Netherlands. Under the "Jansen by Piet Boon" brand, a new design has been developed for doors and partition walls for the upmarket interior sector. The collaboration resulted in a glazing bead that reflects the idea of timelessness and functionality - key concepts within the Piet Boon philosophy.

Piet Boon glazing bead detail measuring just 15 mm welded or glued

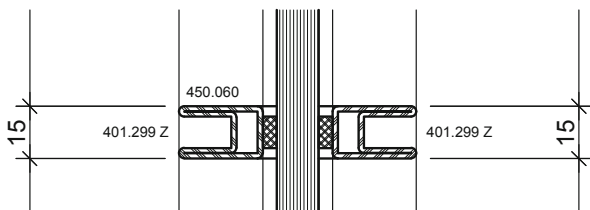

Jansen Art'15 is the platform on which Piet Boon, showcasing a keen eye for detail, developed a glazing bead that emphasises the unique and timeless quality of the door or partition. Piet Boon pays particular attention to ensuring the use of the same glazing bead on both sides to avoid creating a visual break. The 50 mm installation depth of Jansen Art'15 and the narrow face widths of 25 mm to 40 mm are highly stable. Single and double-leaf doors, with or without side or top fixed panels, are possible.

To emphasise the visually calm forms, the use of a lock can be dispensed with. Instead, the element is fitted with magnets at the top, centre, and bottom.

Detail zero threshold by means of a drop-down gasket

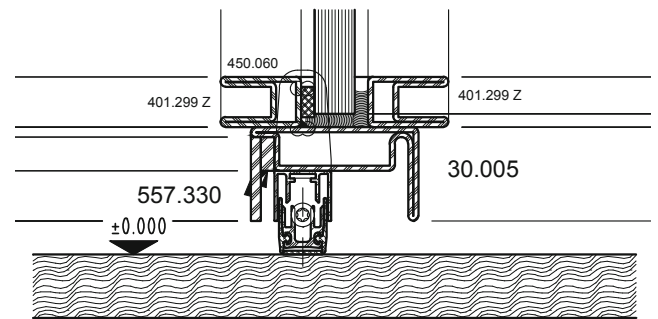

With sizes of W × H 900 mm × 2400 mm and a maximum leaf weight of 100 kg, flush-mounted or openable leaves serve as expansive partitions between interior areas.

In case of indoor use, it is mainly noise and odours that must be kept out. With a sound insulation value of R_w 43 dB and the circumferential gasket including the drop-down floor gasket to prevent odour nuisance, the Jansen Art'15 door can be used as a room divider to the kitchen or as a partition to a swimming pool, for example.

The CO₂ value of this elegant door or partition is satisfyingly low.

Jansen Art'15 is available as a system solution. The Jansen Art'15 version in collaboration with Piet Boon will be available for all markets **from January**.

NEW

Janisol Arte 2.0 Plus RC2 door

Janisol Arte 2.0 in oversize dimensions, for exquisite elegance, additional feature: RC2

With the Janisol Arte 2.0 oversized dimensions, doors measuring up to 3200 mm leaf size can be realised. With just a few additional hardware components, which remain invisible to the observer, the Janisol Arte 2.0 door can be converted into a door with RC2 burglary protection.

With an installation depth of just 60 mm and face widths from 45 mm, Janisol Arte 2.0 Plus is an elegant solution for creating as much transparency as possible with as little visible frame/leaf profiles as possible. This combination of narrow face widths and door leaf heights of up to 3200 mm is unique, and is only possible thanks to the material properties of steel. The door is suitable for the entrance or passageway area of rooms with high ceilings. The door leaf is held in place by just four delicate and powerful 3D hinges and is locked across its entire height on the locking side.

Janisol Arte 2.0 Plus RC2 can be used as an external door. Thermal insulation values, wind/water/air permeability testing and additional burglary protection up to RC2, and the barrier-free threshold variant offer the security that an external door requires. Having undergone mechanical durability testing over 500,000 cycles (class 7), Janisol Arte 2.0 Plus is ideal for commercial and public buildings.

Sustainability criteria can be found in the EPD available for the system.

Zero threshold detail with / without RC2, inward and outward opening

With drainage

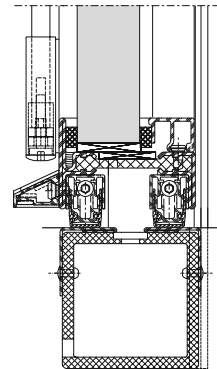

Without drainage

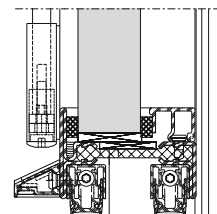

Janisol Arte 2.0 is available as standard in standard dimensions with the RC2 protection class rating. The "Plus" project solution will be available from February 2025, and the additional RC2 option is also expected to be available as a project solution **from summer 2025**.





STUDY

Janisol Arte Panorama sliding door

Make the boundary between internal external spaces disappear

The panoramic sliding door is a study piece by Jansen, that shows what is possible with steel. The trade show exhibit's impressive dimensions of almost 4000 mm in height and 5000 mm in width are by no means the limit of what can be achieved. Leaf element sizes of up to 4000 mm × 3000 mm or 3000 mm × 4000 mm are currently in planning.

Leaf weights of over 800 kg can be accommodated by the stainless steel rollers. A single unit can therefore offer generous views with overall dimensions of up to 6000 mm × 4000 mm or 8000 mm × 3000 mm. The centre section measuring with just 40 mm is so narrow that it offers the eye a point of reference without obstructing the view. The surrounding frame disappears completely into the reveal.

The motor and lock are designed to be sufficiently narrow to disappear into the profile chamber of the frame.

The motorised door leaf weighing around 800 kg is incredibly simple to operate. Automatic operation with dead man's switch guarantees that nothing can go wrong. This, in turn, has a positive impact on aesthetics: there is no need for handles protruding into the glass element.

With panels measuring up to 53 mm thick, the Panorama sliding door contributes to the energy efficiency of a building.

View of the centre section

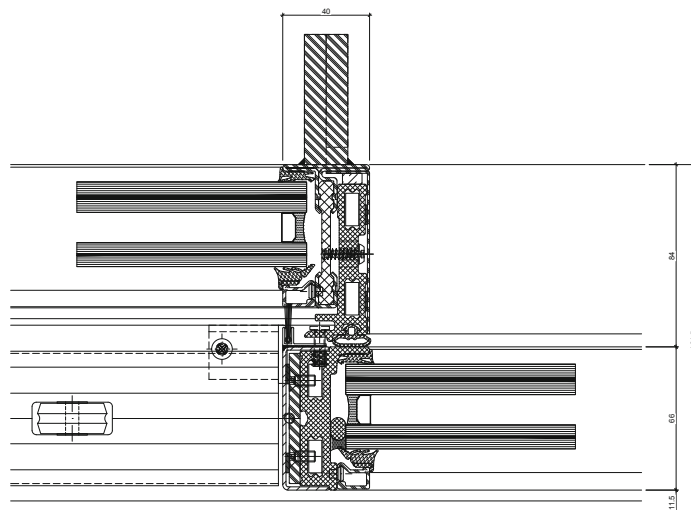

NEW

Jansen Tecline 40 Facade

Steel facade - unbeatably narrow and strong

Less is more! With this in mind, Tecline from Jansen keeps installation depths and face widths to a minimum. Thanks to the outstanding structural properties of steel, the facade system maximises elegance and light penetration - without the need for costly additional measures such as the installation of reinforcing profiles.

The Jansen Tecline mullion/transom facade is a versatile system, with profiles that can be combined with one another and with Jansen Tecline AO (add-on façade) profiles. With a material thickness of 3 mm, the 40 mm wide Jansen Tecline facade is extremely stable. The maximum panel weight of up to 1200 kg enables the use of larger panels. Insert elements with face widths of 90 mm are possible. Another plus point is its ability to be used as roof glazing, with approval granted for angles of inclination of up to 0°.

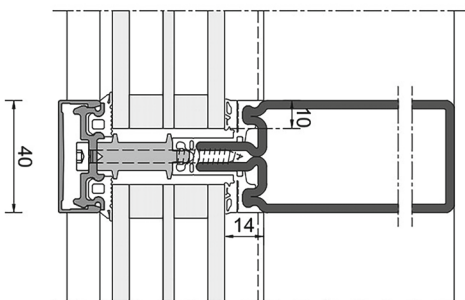
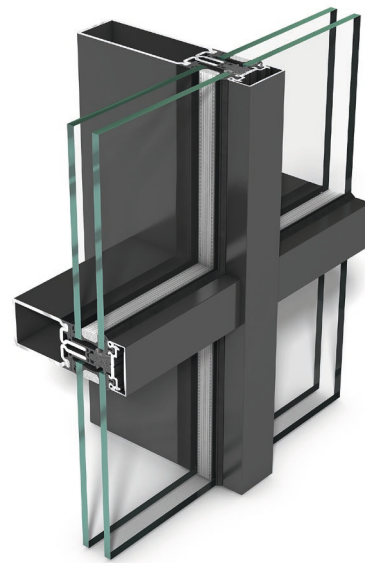

With just a few additional components, the solution can offer burglary protection up to resistance class RC3.

Glass panel thicknesses of up to 60 mm contribute to the energy efficiency of a building.

The Jansen Tecline 40 facade is expected to be available **from spring 2025**.

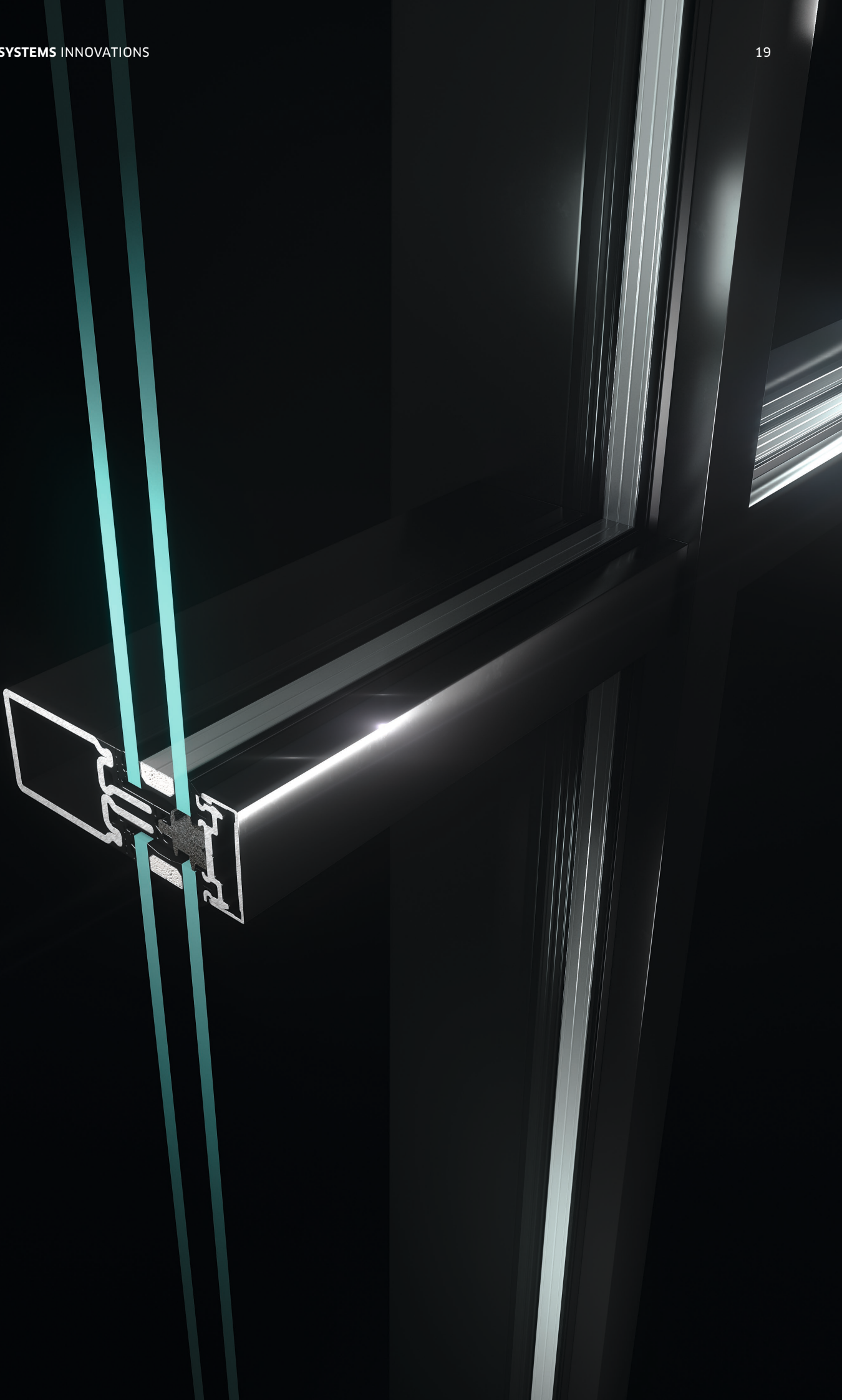



STUDY

Jansen Finesline Vertical pivot window

A space-saving, unusual opening variant allowing in lots of natural light

With in the Jansen Finesline series, the Jansen Finesline window is now available with the vertical pivot window opening variant.

In addition to a minimalist pivot hinge, this design is currently the only on the market to feature an elegant, concealed drainage system that eliminates the need for visible drainage caps. What's more, the pivot hinge is adjustable and thus offers a certain degree of tolerance compensation.

The pivot hinge integrates seamlessly into the narrow face widths of the window system and has a narrow overall appearance, including the insulating bar. With a maximum permissible sash weight of approx. 200 kg, the intended maximum dimensions of W × H 1500 mm × 2300 mm with glass panel thicknesses of 54 mm can be realised with insulated glass.

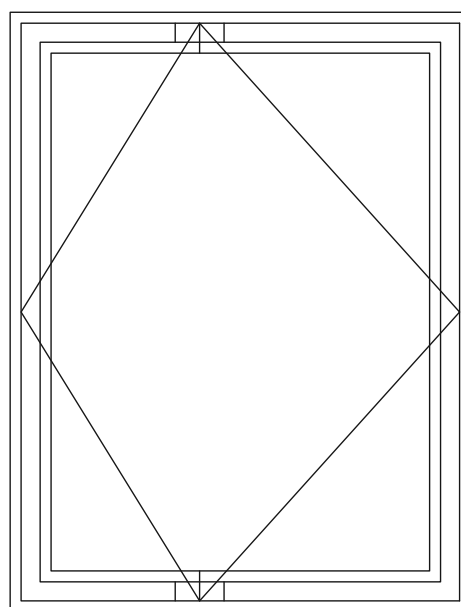

The Jansen Finesline vertical pivot window is already available as a project solution, with **system integration planned for autumn 2025.**

Jansen SimplyTag

Digitalisation for the building industry with a view to creating transparency and efficiency

The Jansen SimplyTag simplifies the daily work of metal fabricators and facility managers.

All data relevant to a component is stored on the Jansen SimplyTag for at least 10 years. This includes the work order, declaration of performance, and CE documents, but also maintenance documents, for example.

The SimplyTag makes it easier for the metal fabricator to hand over the installed elements to the investor, as all documents can be accessed directly from the door/window via QR code.

This means that the facility manager can immediately view all the information on the installed product by scanning the QR code and, in the event of maintenance or servicing, can immediately forward documents to the responsible service provider.

With the SimplyTag, Jansen is taking a pioneering step towards digitalisation in the construction industry.

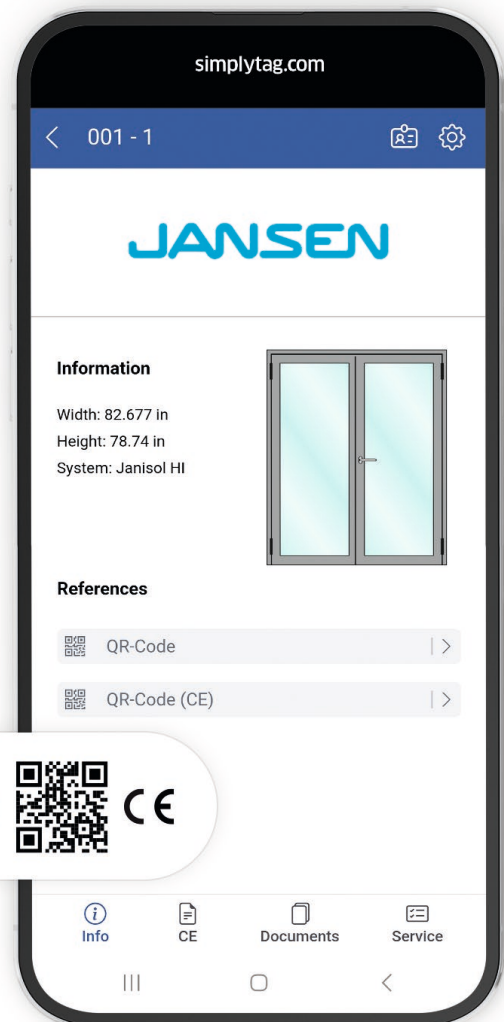

Jansen AG

Steel Systems
Industriestrasse 34
9463 Oberriet
Switzerland
jansen.com

JANSEN